

Worldwide Filtration Manufacturing Locations

North America

**Compressed Air Treatment
Industrial Gas Filtration
and Generation Division**
Lancaster, NY
716 686 6400
www.parker.com/GSF

Balston
Haverhill, MA
978 858 0505
www.parker.com/balston

Engine Filtration & Water Purification Racor

Modesto, CA
209 521 7860
www.parker.com/racor

Racor
Holly Springs, MS
662 252 2656
www.parker.com/racor

Racor
Beaufort, SC
843 846 3200
www.parker.com/racor

Racor – Village Marine Tec.
Gardena, CA
310 516 9911
desalination.parker.com

**Hydraulic Filtration
Hydraulic Filter**
Metamora, OH
419 644 4311
www.parker.com/hydraulicfilter

**Process Filtration
domnick hunter Process Filtration**
Oxnard, CA
805 604 3400
www.parker.com/processfiltration

Europe

**Compressed Air Treatment
domnick hunter Filtration & Separation**
Gateshead, England
+44 (0) 191 402 9000
www.parker.com/dhfs

Parker Gas Separations
Etten-Leur, Netherlands
+31 76 508 5300
www.parker.com/dhfs

Hiross Zander
Padova Business Unit
Padova, Italy
+39 049 9712 111
www.parker.com/hzd

Hiross Zander
Essen Business Unit
Essen, Germany
+49 2054 9340
www.parker.com/hzd

**Engine Filtration &
Water Purification
Racor**
Dewsbury, England
+44 (0) 1924 487 000
www.parker.com/rfde

Racor Research & Development
Stuttgart, Germany
+49 (0)711 7071 290-10
www.parker.com/rfde

**Hydraulic Filtration
Hydraulic Filter**
Arnhem, Holland
+31 26 3760376
www.parker.com/hfde

Ujala Operation
Ujala, Finland
+358 20 753 2500
www.parker.com/hfde

Condition Monitoring Center
Norfolk, England
+44 1842 763 299
www.parker.com/hfde

**Process Filtration
domnick hunter Process Filtration**
Birtley, England
+44 (0) 191 410 5121
www.parker.com/processfiltration

Asia Pacific

Australia
Castle Hill, Australia
+61 2 9634 7777
www.parker.com/australia

China
Shanghai, China
+81 22 651 370 8185
www.parker.com/china

India
Navi Mumbai, India
+91 22 651 370 8185
www.parker.com/india

Japan
Tokyo, Japan
+81 45 870 1522
www.parker.com/japan

Korea
Hwaseon-City
+82 31 359 0852
www.parker.com/korea

Singapore
Jurong Town, Singapore
+65 6887 6300
www.parker.com/singapore

Thailand
Bangkok, Thailand
+66 2 186 7000
www.parker.com/thailand

**Latin America
Parker Comercio Ltda.
Filtration Division**
Sao Paulo, Brazil
+55 12 4009 3500
www.parker.com/br

Pan American Division
Miami, FL
305 470 8800
www.parker.com/panam

Africa
Aeroport Kempton Park, South Africa
+27 11 9610700
www.parker.com/africa

Parker Hannifin Corporation
**Industrial Gas Filtration
and Generation Division**
4087 Walden Avenue
Lancaster, NY 14086
phone 800 343 4048
www.parker.com





Mist Eliminators

125 - 12,000 scfm



Installation Manual

MAINTENANCE & EXAMINATION RECORD

OWNERSHIP DATA

MODEL NO: COMMISSIONED BY:
(please print)

SERIAL NO: COMPANY NAME:

INSTALLATION DATE: TELEPHONE NO:

COMMISSIONING DATE: SERVICE PLAN:

INSPECTION/EXAMINATION		REPAIR/MAINTENANCE (IF ANY)	
Name	Signature	Date	Summary Remarks

MODEL	A in (mm)	B in (mm)	C in (mm)	D in (mm)	E in (mm)	F in (mm)	G in (mm)	H in (mm)	I in (mm)	J in (mm)	ELEMENT CODE
PME125	20-3/8 (517)	10-7/8 (276)	9-5/8 (245)	9-1/2 (241)	19 (483)	14-7/8 (378)	26-3/4 (679)	41-5/8 (1057)	43-7/8 (1115)	63-1/8 (1603)	K125PME
PME250	20-3/8 (517)	10-7/8 (276)	9-3/4 (248)	9-1/2 (241)	19 (483)	15 (381)	32-1/8 (816)	47-1/8 (1197)	48-3/8 (1229)	74-5/8 (1895)	K250PME
PME500	17-1/4 (438)	10-7/8 (276)	9-3/4 (248)	9-1/2 (241)	19 (483)	14-7/8 (378)	46-5/8 (1184)	61-1/2 (1562)	63-3/4 (1620)	103 (2616)	K500PME
PME1000	20-1/2 (521)	11 (279)	9-5/8 (245)	9-1/2 (241)	19 (483)	17-3/8 (442)	55 (1413)	73 (1855)	76-3/4 (1950)	103 (2616)	K1000PME
PME1200	25-3/4 (654)	14 (356)	11-3/4 (298)	11-3/4 (298)	23-1/2 (597)	19-3/8 (493)	49-1/4 (1251)	68-5/8 (1743)	72-3/8 (1839)	111-1/8 (2823)	K1200PME
PME1500	25-3/4 (654)	14 (356)	11-3/4 (298)	11-3/4 (298)	23-1/2 (597)	21 (533)	58 (1473)	79 (2007)	83-1/2 (2121)	132-7/8 (3375)	K1500PME
PME2000	28-7/8 (734)	15-1/8 (384)	13-7/8 (353)	13-3/4 (349)	27-1/2 (699)	24-1/4 (616)	49-7/8 (1267)	74-1/8 (1984)	78-5/8 (1997)	118-5/8 (3013)	K2000PME
PME3000	28-3/4 (730)	15 (381)	13-3/4 (349)	13-3/4 (349)	27-1/2 (699)	24 (610)	59 (1499)	83 (2108)	87-1/2 (2223)	118-5/8 (3013)	K3000PME
PME4500	30-1/2 (775)	16-3/4 (425)	13-3/4 (349)	13-3/4 (349)	27-1/2 (699)	27-1/2 (699)	52-1/4 (1327)	79-3/4 (2026)	85-1/4 (2166)	128-1/8 (3254)	K4500PME
PME6000	30-1/2 (775)	16-3/4 (425)	13-3/4 (349)	13-3/4 (349)	27-1/2 (699)	27-1/2 (699)	62-1/4 (1581)	89-3/4 (2280)	95-1/4 (2420)	128-1/8 (3254)	K6000PME
PME8000	34-3/4 (883)	18-3/4 (476)	16-1/8 (410)	16 (406)	32 (813)	34-1/2 (876)	63-5/8 (1616)	98-1/8 (2492)	104-7/8 (2664)	128-1/8 (3254)	K8000PME
PME10000	CF	CF	CF	CF	CF	CF	CF	CF	CF	CF	K10000PME
PME12000	CF	CF	CF	CF	CF	CF	CF	CF	CF	CF	K12000PME

INSTALLATION, OPERATION & MAINTENANCE

Install Parker Airtek Mist Eliminator in a suitable location on a level floor. It is recommended that the filter be secured to the floor by using the anchoring holes on the legs.

Drains

A suitable drain must be fitted to the bottom of filter downstream of an isolation valve.

Automatic drain models should be inspected regularly to ensure correct drain operation.

Differential Pressure Gauge (DPG) Kit Specifications

1. Maximum operating pressure: 300 psi g (20.7 bar g).
2. Maximum operating temperature: 200°F (93°C).
3. Connections: 1/8" NPT Connections
*If operating temperature is greater than 200°F (93°C), remove the DPG Kit.
*Option - Remote sensing switch shown on top of DPG

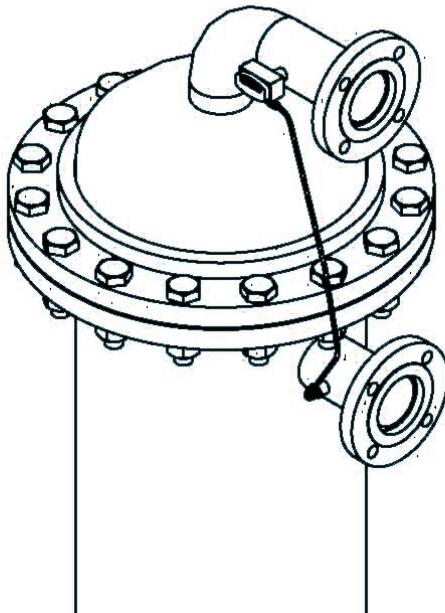

REPLACEMENT OF FILTER ELEMENT

1. Replace filter element every 5 years or when gauge needle indicates 'RED'.
2. Isolate air (gas) supply and depressurize filter housing by opening valve.
3. Remove nuts and bolts from the body flange allowing blind flange to be removed.
4. Raise top flange with element attached.
5. Unscrew nuts on the underside to the element support plate.
6. Remove element support plate, complete with element.
7. Take this opportunity to clean inside of housing and inspect for any signs of corrosion.
8. Apply a light coating of paraffin grease to replacement gasket and position.
9. Replace element and support plate.
10. Tighten nuts on the support plate evenly.
11. Inspect all body gasket surfaces and replace if damaged.
12. Tighten nuts and bolts evenly.
13. Slowly repressurize filter housing and check for leaks.

AUTOMATIC DRAINS

1. Isolate air (gas) supply by closing valve.
2. Depressurize drain by opening vent valve.
3. Drain can now be removed.
4. Dismantle drain by removing clamp ring - this is achieved by pressing tab on ring while turning.
5. When replacing drain DO NOT pressurize unit unless drain is properly fitted

TECHNICAL SPECIFICATION

1. Maximum Working Pressure
232 psi g (18 bar g)
2. Maximum Operating Temperature
200°F (93°C)
3. PME125 - PME500
Inlet/Outlet connections: 2" NPT
4. PME1000 - PME12000
Inlet/Outlet connections: ANSI
B16.5 cl 150 RFSO flanges
5. PME125 - PME12000
3 legs with 3 holes located (as
shown) to properly secure unit to
a base.

