

## Product Overview

### Precision Indexing | Indexers, Conveyors, Part Handlers

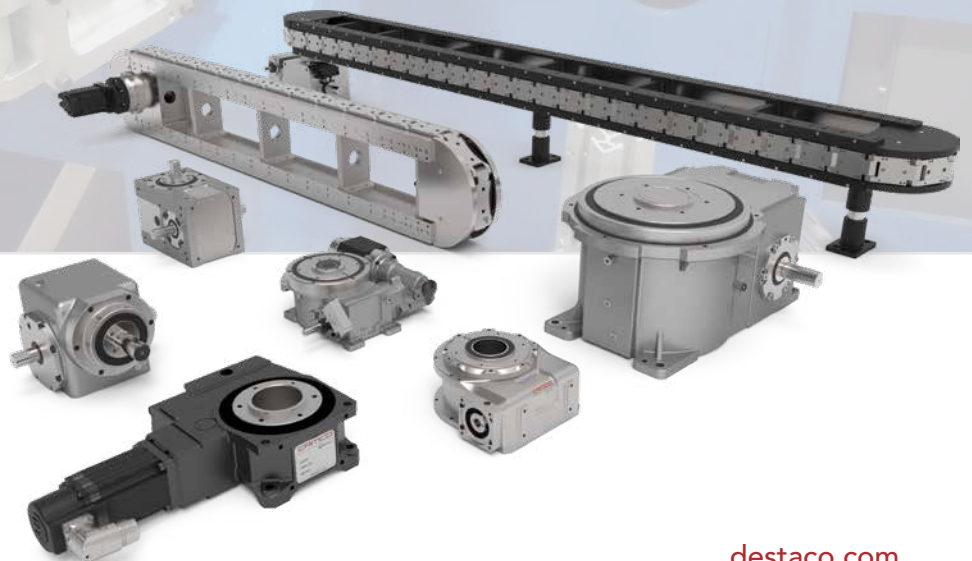

## Built on a Strong Foundation

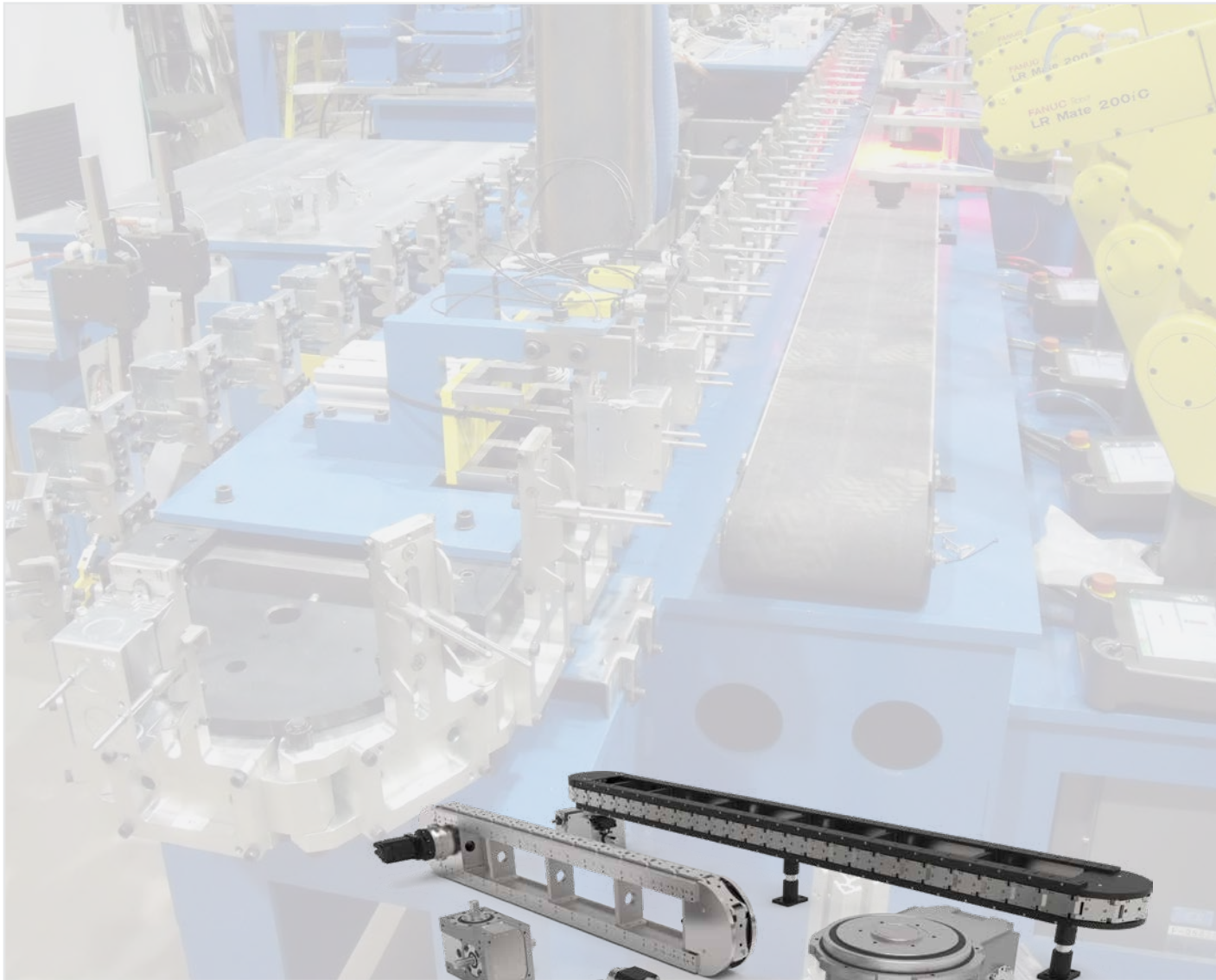
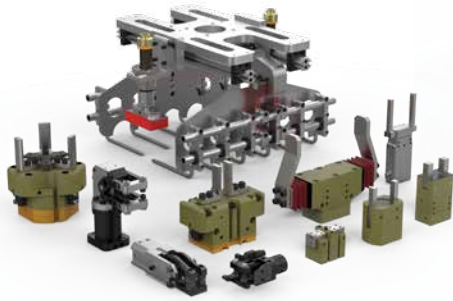

Gripping Solutions



Linear Positioning Solutions



Rotary Positioning Solutions



Clamping Solutions



CRL Remote Handling Solutions



Robotic Tooling Solutions

Destaco, a Dover company, is a global leader in the design and manufacture of high-performance automation, workholding and remote-handling solutions. The company serves customers in a variety of end-markets, including the automotive, life sciences, consumer packaged goods, aerospace, industrial and nuclear sectors.

Built on a legacy of more than 100 years, Destaco offers a comprehensive portfolio of products designed to engineer precise movement, placement and control solutions that drive productivity and uptime for manufacturers around the world. The Destaco family of products consists of industry-leading brands such as Destaco Manual Clamps, Power Clamps, and End Effectors; CAMCO™ and Ferguson™ Indexers; Robohand™ Grippers; and CRL™ Manipulators and Transfer Ports.

Destaco is based in Auburn Hills, Michigan, U.S.A. The company has more than 800 employees with 13 locations, in 9 countries, across the Americas, Europe and Asia.

Destaco is part of Dover Corporation, a diversified global manufacturer with annual revenues of \$7 billion. The company delivers innovative equipment and components, specialty systems and support services through four major operating segments: Energy, Engineered Systems, Fluids, and Refrigeration & Food Equipment. Headquartered in Downers Grove, IL, (NYSE: DOV)

More information is available at [destaco.com](http://destaco.com) and [dovercorporation.com](http://dovercorporation.com)

**Focusing all of our Resources**

**New Product Development**

Destaco has dedicated resources to design and build the next generation of products and solutions

**Customer Service and Technical Support**

Destaco has industry leading global support to address any product and application concerns you may have

**Design Tools**

Destaco provides an extensive CAD library, sizing software, and online tools to support our global customers



**Our Insight Working for You**

**Application Engineering**

We utilize our expertise and complete portfolio of products to create solutions that fit our customers' needs and applications

**Custom Solutions**

If our off-the-shelf solutions don't fit, we will partner with our customers to develop products that will



**Rotary Indexers and Conveyor Solutions**

**Smarter Precision Indexing**

Destaco's CAMCO products have been the industry standard for the highest quality cam-actuated motion control products available. Destaco manufactures a wide range of motion control products including indexing drives, linear and rotary parts handlers, precision link conveyors, magnetically-propelled conveyors, servo-mechanical drives, and custom cams.

**CLICK OR SCAN**  
QR code for full catalog pages on these products



Markets



Applications

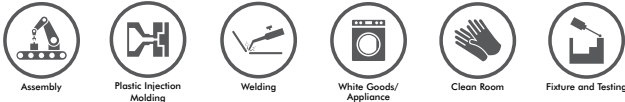



## GTB Series

### Servo Positioners

- High payload compact size indexing solutions
- Freely programmable servo reducer indexers
- Zero maintenance lubricated for life
- Supports both horizontal and vertical mounting
- Compatible with multiple brands of servo motors



## RSD Series

### Zero-backlash Flexible Rotary Servo Drive Solutions

- Cam-actuated drive servo driven for precise control
- Preloaded for zero backlash, high accuracy, and smooth motion
- 4:1 to 18:1 ratio in single state
- Compatible with variety of industry-standard servo motors



## RDM Series

### Low Profile Roller Dial Index Drives

- Large center through-hole for air, electric and hydraulic utilities
- Superior thrust and moment capacity due to large output mounting surface that is supported by a 4-point contact bearing
- Variety of drive packages with optional overload clutch feature



## RD Series

### Roller Dial High-Load Index Drives

- Well suited for continuous running operations via short camshaft motion periods and special motion requirements.
- Universal mounting supports horizontal and trunnion mount applications
- Center through-hole for air, electric, hydraulic and mechanical linkages utilities
- Customized motions available including oscillating motions



## E-Series

### Heavy-Duty Large Moment Index Drives

- Ideal for Automotive and other applications requiring high precision index positioning
- Superior thrust and moment capacity due to large output mounting surface that is supported by a 4-point contact bearing
- Delivers smooth acceleration and deceleration using a preloaded "center rib" design

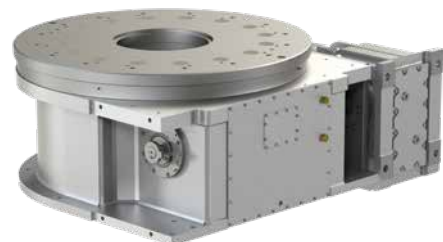

## CLICK OR SCAN

QR codes for full catalog pages on these products

## RA Series

### Roller Dial High-Load Index Drives

- Well suited for continuous running operations via short camshaft motion periods and special motion requirements.
- Universal mounting supports horizontal and trunnion mount applications
- Center through-hole for air, electric, hydraulic and mechanical linkages utilities
- Customized motions available including oscillating motions



## RGD/RGS Series

### Roller Gear Index Drives

- Robust flexible unit supporting a wide variety of industrial applications
- Universal mounting includes mounting holes on all six sides
- Customized motions available including oscillating motions or short index periods



## Parallel Index Drives

### High Speed and High Load Capability Solutions

- Ideal for high speed conveying or driving mechanical linkage applications
- Backlash-free rigid operation
- Provides Long transfer distances with simple linkages
- Whole or fractional stops, oscillating and complex custom motions available

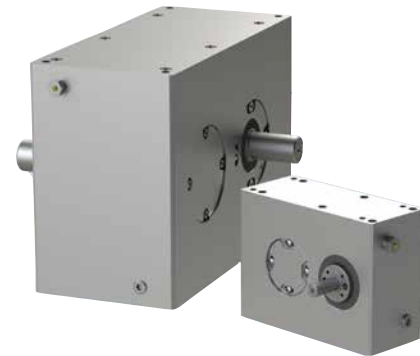

## RNG Ring Index Drives

### Automatic Assembly Machinery Application Solution

- Ideal for pad printing, decorating equipment and applications requiring up to 60 workstations with minimal floor space.
- Easy serviceability access and mounting auxiliary equipment
- Superior accuracy and load capability using sealed 4-point contact output bearing
- Application flexibility and easy maintenance with modular shaft-mounted reducers

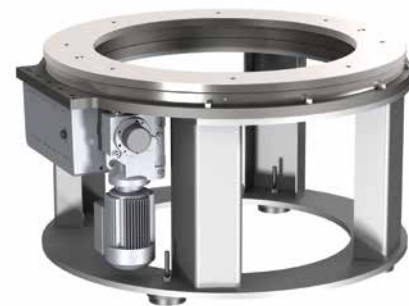

## Rite-Link Series

### Thin Profile Pre-assembled Conveyor

- Maintenance free accuracy and durability industrial conveying applications
- Faster and more accurate precision link system over roller chain conveyors
- Oversized tooling supported in a slim, compact conveyor design
- Designed to your specifications, fully assembled and tested by Destaco

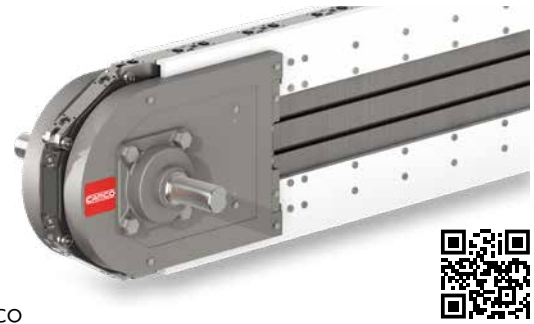

## Precision Link Conveyor

### Multiple-Station Chassis Table Top Solutions

- Ideal for modular assembly of complicated products requiring precision positioning of parts.
- Open frame design supports pass through of belting, linkages, electric or air supply components
- 3 to 40 feet Conveyor lengths with link pitch of 3, 4.5, and 6 inches
- Quick assembly and delivery using a modular 18" increment frame design



## Heavy Duty Precision Link Conveyors

### Modular, Accurate with High-Load Capacity

- Maintenance free accuracy and durability industrial conveying applications
- Faster and more accurate precision link system over roller chain conveyors
- Oversized tooling supported in a slim, compact design
- Designed to your specifications, fully assembled and tested



## CLICK OR SCAN

QR codes for full catalog  
pages on products

## LPP Series

### Linear Parts Handler

- Cost effective design for low-cost operation
  - Reliable CAMCO mechanical cam design
  - Lubed for Life
- Easy integration with other Destaco products for one-stop shopping
- Input shaft available on either side for ease of integration
- Line shaft drive or gear reducer and motor drive package for synchronous or asynchronous operation
- Standard or custom strokes and timing designed to your specific requirements



## RPP Series

### Rotary Parts Handler

- Rugged and precise cam operated mechanisms engineered for a minimum of 8000 hours of maintenance-free life.
- Hardened and ground cams drive both the lift and rotary axes
- Preloaded precision cam followers eliminate backlash and ensure smooth movement
- Preloaded taper roller bearings on the camshaft (Input Shaft)
- Four-point contact preloaded roller bearing on the rotary axis
- All bearings are lubricated by an oil bath
- One-piece lift arm



## Overload Clutches

### Output Overload Protection

- Easily mounts to CAMCO Index Drives
- Single position reset to maintain accuracy and machine timing
- Precision hardened and ground plungers and drive plate
- Overload detector plate provides actuation for overload detector switch
- Variety of models for all applications
- Standard & custom torque settings



## Custom Cams

### Design and Manufacturing Services

- Backed by 100 years of experience
- Comprehensive range of configurations, tolerances and materials
- Precise, economical and engineered for your exacting specifications
- Alternative to "in-house" design, engineering and manufacturing



## Fixed and Flexible Dials, Conveyors and Parts Handlers

### Cycle on Demand Indexer with Fixed Number of Stations

- RDM indexer with user controlled variable dwell time
- Single index cycle with user controlled variable dwell time
- Index time is controlled by varying frequency setting of inverter drive
- 60 or 30 indexing cycles per minute using an AC or DC motor and drive respectively

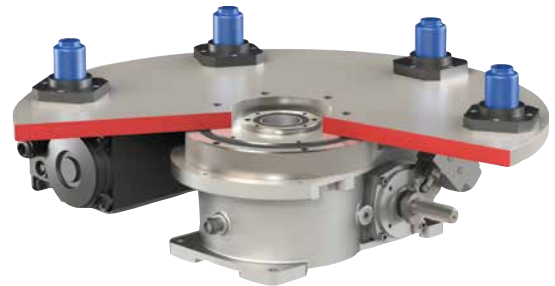

### Servo Driven Indexer with Variable Number of Stations

- 115RSD indexer with user controlled variable dwell time
- Single index cycle with user controlled variable dwell time
- Index time is controlled by varying motion profile of servo motor
- Supports single-axis and multi-axis servo controllers
- Exceeds 60 indexing cycles per minute



### Conveyor and Linear Part Handlers Controlled by Indexer

- Integrated solutions center using indexer, conveyor and part handlers
- User controlled variable dwell time by varying motion profile of servo motor
- Supports single-axis and multi-axis servo controllers
- Exceeds 60 indexing cycles per minute

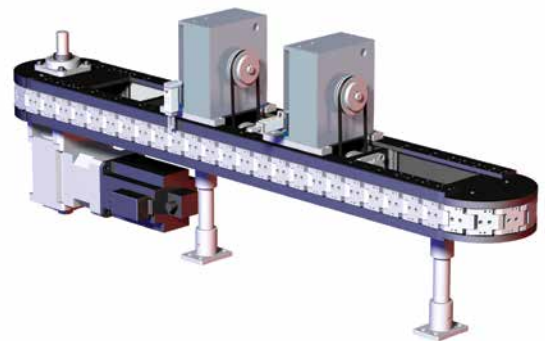

### Pick and Place or Load and Unload with Grippers

- Integrated solutions using Robohand Grippers, Rotaries and Cambot LPP Part handlers
- Create customized rotary pick and place application solutions
- PLC Sequencing logic used for Motion axis and gripper action





## Flexible Multi-Axis and High Speed

### Cambot Flexible Pick and Place Solutions

- Servo driven indexer supporting high moment capacity payloads
- Large output flange for mounting a custom end-effector solution
- Integrate Destaco's versatile grippers, slides and vacuum products for pick and place actuation



### Tube Cutting Variable Length Flying Cutoff

- Cut to length formed tube using coupled CAMCO Roller Gear models
- Servo motor drives both gear boxes and maintains synchronization with speed variations of tube line.
- Indexer (A) moves the cutting tool into the correct position adapting to line speed variations
- The Oscillator (B) moves the cutting tool up and down
- Tube length is controlled by increasing arm length (A) or allowing the tube to flow out before cycling servo motor

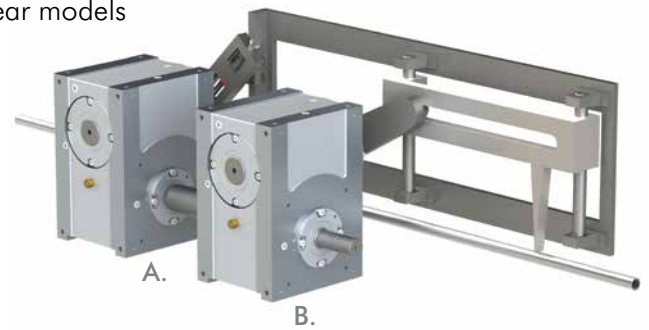

### Paper or Plastic Web High Speed Contouring Application

- Processes 1000 Parts per minute For high speed contouring
- Uses two lasers cutting tools mounted to the oscillating arms
- Customized to customers application pattern
- Destaco designed custom cams to meet the application specifications
- Produces a dynamically stable cam solution requiring no maintenance
- Servos are linked to the web line keeping it in sync for the application

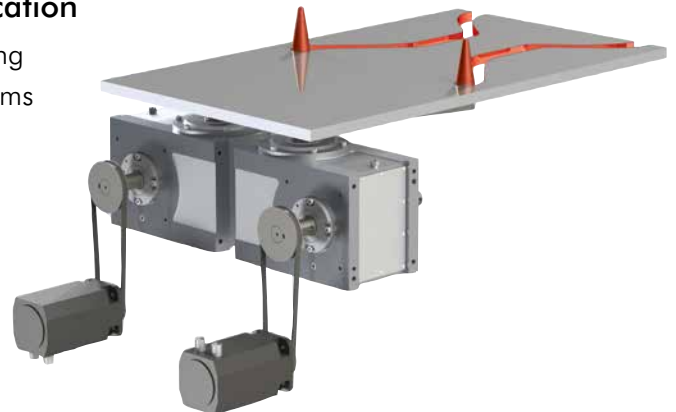

### Large Moment Capacity Rotary Motion Application

- Heavy-Duty E-Series Index Drive with large center utility thru-hole to accommodate electrical, air and hydraulic lines
- Delivers high precision index positioning with smooth acceleration and deceleration
- Superior thrust and moment capacity due to large output mounting surface, supported by a 4-point contact bearing

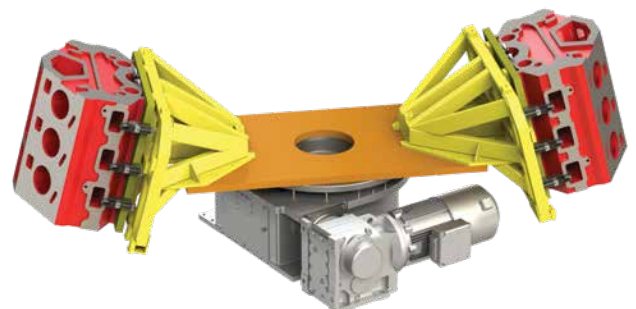

# COMPLETE HIGH SPEED PRECISION SOLUTIONS

Destaco with CAMCO and Robohand products offer complete standard and custom automation solutions for high speed, precision indexing and pick-and-place applications.

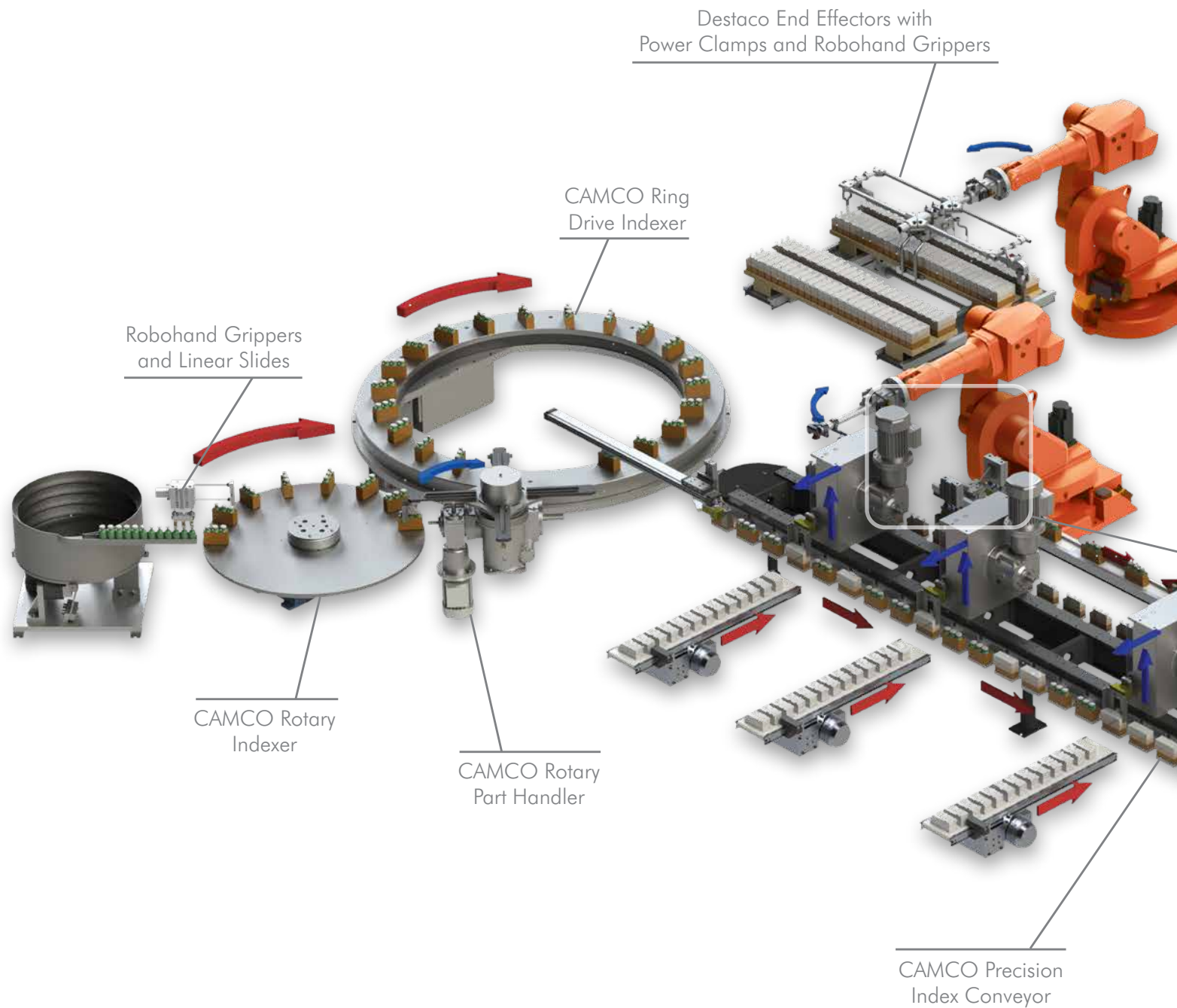

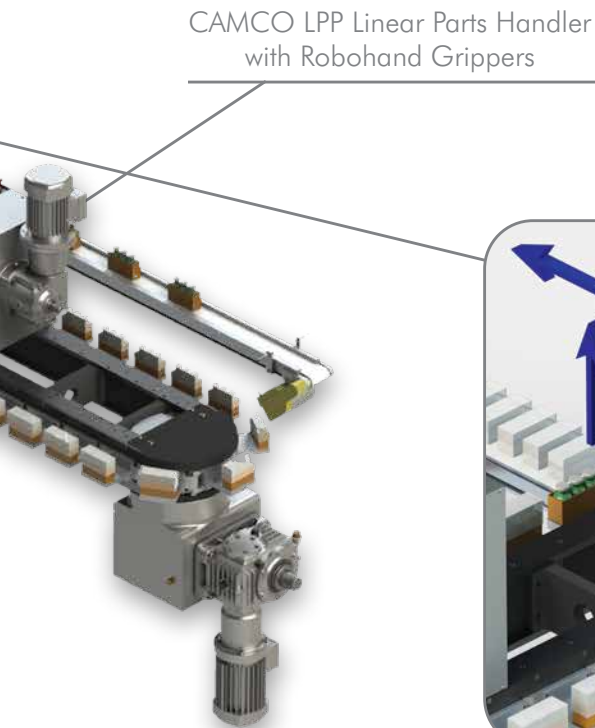
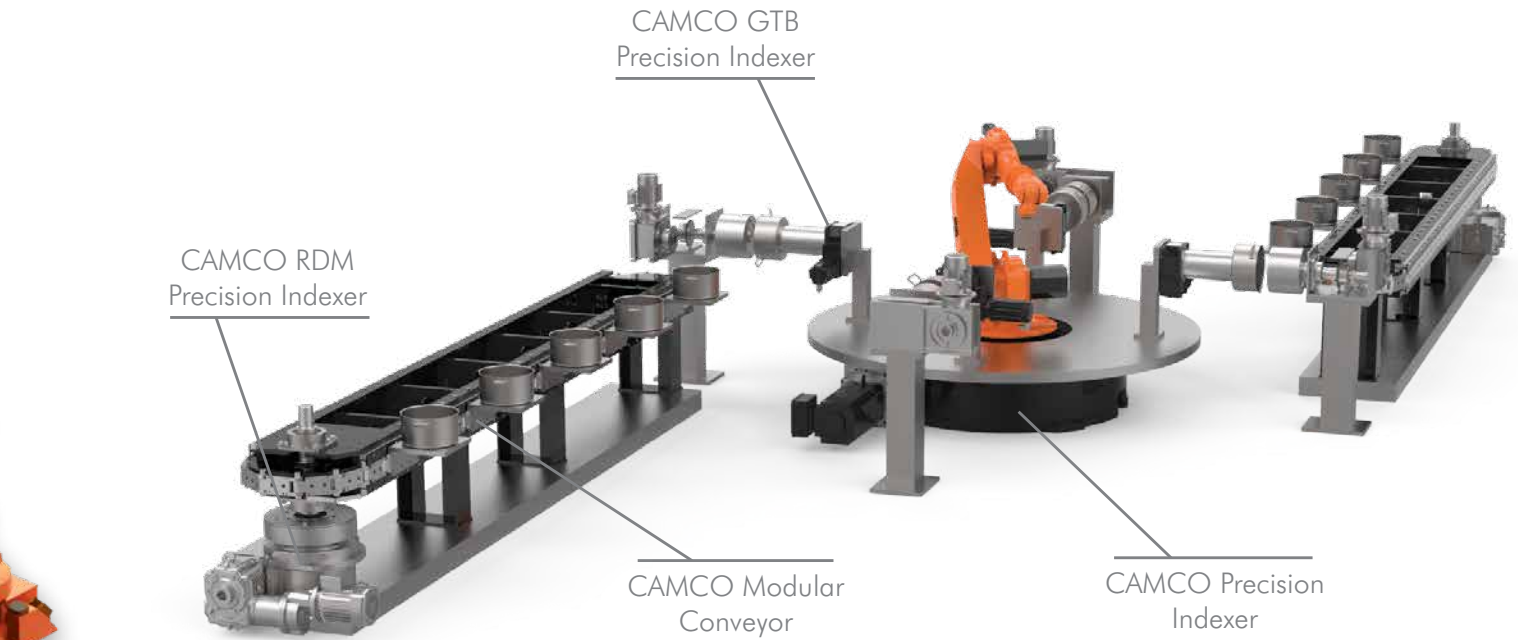

Robohand Rotaries,  
Slides and Grippers

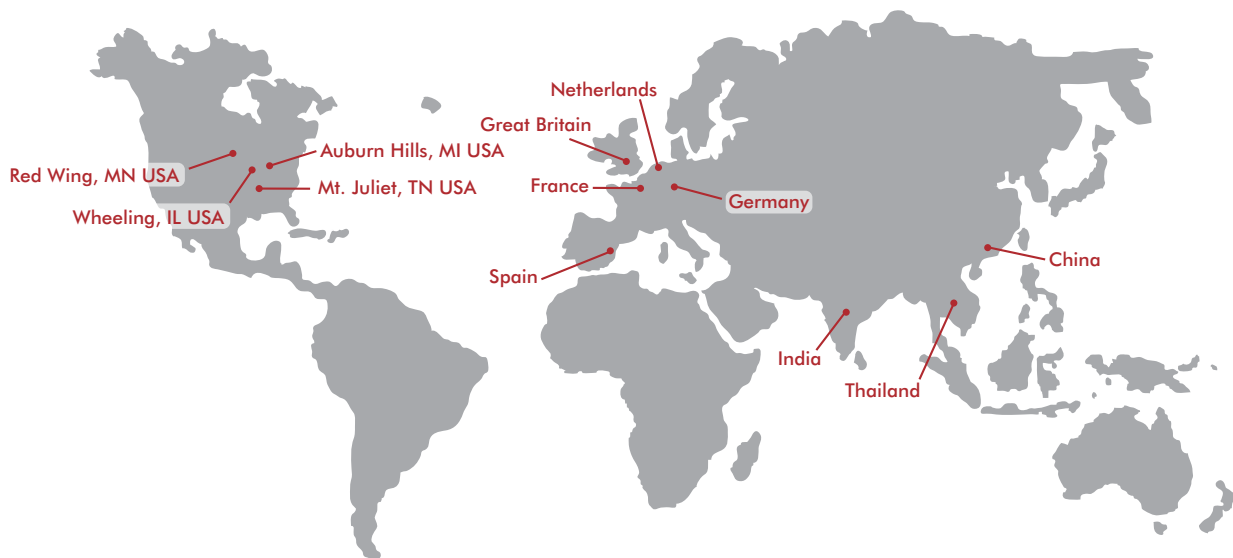

## GLOBAL LOCATIONS

### NORTH AMERICA

#### Corporate Headquarters

Auburn Hills, Michigan  
Toll Free: 1.888.DESTACO  
Marketing: [marketing@destaco.com](mailto:marketing@destaco.com)

#### Global Technology Center

Auburn Hills, Michigan  
Tel: 1.248.836.6700  
Customer Service: [customerservice@destaco.com](mailto:customerservice@destaco.com)

Mt. Juliet, Tennessee  
Tel: 1.888.DESTACO  
Customer Service: [customerservice@destaco.com](mailto:customerservice@destaco.com)

Wheeling, Illinois  
Tel: 1.800.645.5207  
Customer Service: [camco@destaco.com](mailto:camco@destaco.com)

Red Wing, Minnesota (Central Research Laboratories)  
Tel: 651.385.2142  
Customer Service: [sales@centres.com](mailto:sales@centres.com)

### ASIA

Thailand  
Tel: +66-2-326-0812  
Customer Service: [info@destaco.com](mailto:info@destaco.com)

China  
Tel: +86-21-6081-2888  
Customer Service: [china@destaco.com](mailto:china@destaco.com)

India  
Tel: +91-80-41123421-426  
Customer Service: [india@destaco.com](mailto:india@destaco.com)

### EUROPE

Germany  
Tel: +49-6171-705-0  
Customer Service: [europe@destaco.com](mailto:europe@destaco.com)

France  
Tel: +33-4-73545001  
Customer Service: [france@destaco.com](mailto:france@destaco.com)

Great Britain  
Tel: +44-1902-797980  
Customer Service: [uk@destaco.com](mailto:uk@destaco.com)

Spain  
Tel: +34-936361680  
Customer Service: [spain@destaco.com](mailto:spain@destaco.com)

Netherlands  
Tel: +31-297285332  
Customer Service: [benelux@destaco.com](mailto:benelux@destaco.com)

**CLICK OR SCAN**  
QR code for the  
latest PDF version  
of this document

