

## Manual Clamp Products

04/11/2022



**Motion & Flow Control Products**

303-781-7362

digitalsales@mfcpc.com

automationsales@comoso.com

www.mfcpc.com



# Manual Clamp Products

04/11/2022

This catalog is a custom document and the products included is based on your unique selection from portions of complete catalogs that already exist. Please refer to our full catalogs for more information on products not included in this customized document.

## Table of Contents

Technical Comparison Chart (MC)	MC-TCH-1
Vertical Hold Down Clamps	MC-VHD-1
Horizontal Hold-Down Clamps	MC-HHD-1
Straight Line Action (Plunger) Clamps	MC-SLA-1
Variable Stroke Clamps	MC-VSC-1
Pull Action (Latch) Clamps	MC-PAL-1
Squeeze Action (Plier) Clamps	MC-SAP-1
Manual Accessories	MC-ACC-1
Pneumatic Toggle Clamps	MC-PTC-1
Pneumatic Swing Clamps	MC-PSC-1
Pneumatic Power Cylinders	MC-PPC-1
Technical Appendix	MC-TEC-1
Hydraulic Systems	MC-HYD-1

# Manual Clamp Products

04/11/2022

## Table of Contents (continued)











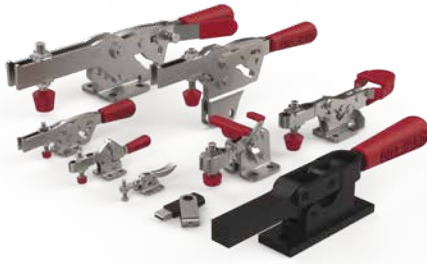

# HORIZONTAL HOLD DOWN CLAMPS

## Sizing and Application Chart

CLICK OR SCAN  
To view full PDF  
catalog pages on  
these products



Series	Page MC-HHD-#	Max. Holding Capacity N [lbf.]					Height Under Clamping Bar mm [inch]					Overall Height mm [inch]								
		0 to 1000 [0 to 225]	1000 to 2000 [225 to 450]	2000 to 3000 [450 to 675]	3000 to 5000 [675 to 1125]	5000 to 7000 [1125 to 1575]	7000 to 10000 [1575 to 2250]	0 to 10 [0 to 0.39]	10 to 20 [0.39 to 0.79]	20 to 30 [0.79 to 1.18]	30 to 40 [1.18 to 1.57]	40 to 50 [1.57 to 1.97]	50 to 60 [1.97 to 2.36]	0 to 25 [0 to 0.98]	25 to 40 [0.98 to 1.57]	40 to 55 [1.57 to 2.17]	55 to 70 [1.57 to 2.76]	70 to 85 [2.76 to 3.35]	85 to 100 [3.35 to 3.94]	100+ [1.57+]
 2013  217  227  235  305  206  5310	2013	1	•					•						•						
	2017	3		•				•	•						•					
	2027	5			•					•						•				
	213	7		•					•											
	217	9	•	•						•										
	227	11			•						•						•			
	237	13				•						•						•		
	245	15											•							•
	205	17	•							•										
	215	19		•	•						•				•					
	225	21			•							•				•				
	235	23				•							•				•			
	305	25	•							•					•					
	307	25		•							•						•			
309	25				•						•								•	
206	27	•												•						
5305	29			•						•				•						
5310	29								•		•				•					



**CLICK OR SCAN**  
To view full PDF  
catalog pages on  
these products

# HORIZONTAL HOLD DOWN CLAMPS

## Sizing and Application Chart

Overall Length mm [inch]		Overall Width mm [inch]		Suitable Application Areas										Standard Material		Arm Style		Mounting Style		Service Environ- ment												
50 to 75 [1.97 to 2.95]	75 to 100 [2.95 to 3.94]	100 to 125 [3.94 to 4.92]	125 to 150 [4.92 to 5.91]	150 to 175 [5.91 to 6.89]	175 to 200 [6.89 to 7.87]	200 to 225 [7.87 to 8.86]	225 to 250 [8.86 to 9.84]	250+ [9.84+]	0 to 25 [0 to 0.98]	25 to 40 [0.98 to 1.57]	40 to 55 [1.57 to 2.17]	55 to 70 [1.57 to 2.76]	Welding	Assembly	Checking Fixtures	Machining	Woodworking	Closures	Food Processing	Duty Cycle	Steel	Stainless Steel	Toggle Lock Plus	U-Bar Version	Solid Arm Version	Straight Base	Flanged Base	Welded	Normal	Harsh/Dirty		
			●										○	●	●	●	●	●	●	○	●		●	●			●	●		●	●	
						●				●	●		○	●	●	●	●	●	●	○	○	●		●	●		●	●		●	●	
							●				●		○	●	●	○	●	●	●	○	○	●	●	●			●	●		●	●	
			●							●			○	●	●	●	●	●	○	○	○	●	●		●	●		●	●		●	●
													○	●	●	○	●	●	○	○	○	○	●	●			●	●		●	●	
●			●						●				○	●	●	●	●	●	○	○	○	○	○	○	○	○	○	○	○	○	○	○
●									●				○	●	○	○	○	○	○	○	○	○	○	○	○	○	○	○	○	○	○	○
●	●										●		○	●	○	○	○	○	○	○	○	○	○	○	○	○	○	○	○	○	○	○
●			●						●				○	●	○	○	○	○	○	○	○	○	○	○	○	○	○	○	○	○	○	○
							●						○	●	○	○	○	○	○	○	○	○	○	○	○	○	○	○	○	○	○	○
								●					○	●	○	○	○	○	○	○	○	○	○	○	○	○	○	○	○	○	○	○

● Excellent/High ○ Fair/Medium ● Poor/Low ⊗ Not Recommended













# STRAIGHT LINE ACTION CLAMPS

## Sizing and Application Chart

CLICK OR SCAN  
To view full PDF  
catalog pages on  
these products

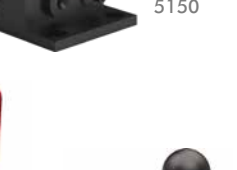

Series	Page MC-SLA-#	Max. Holding Capacity N [lbf.]					Plunger Travel mm [inch]				
		0 to 1000 [0 to 225]	1000 to 2000 [225 to 450]	2000 to 3000 [450 to 675]	3000 to 5000 [675 to 1125]	5000 to 7000 [1125 to 1575]	7000 to 10000 [1575 to 2250]	10000+ [2250+]	0 to 20 [0 to 0.79]	20 to 40 [0.79 to 1.57]	40 to 60 [1.57 to 2.36]

 6001	6001	1	●					●				
 601	601	2	●					●				
 6015	6015	3		●				●				
 603	603	5		●					●			
 608	608	5			●					●		
 605	605	7		●					●			
 606	606	8		●					●			
 607	607	9			●					●		
 609	609	10		●					●			
 610	610	11			●					●		
 615	615	12		●					●			
 620	620	13			●				●			
 630	630	14						●		●		
 640	640	15						●			●	
650	650	16						●			●	
95030	95030	17		●					●			
95040	95040	17			●				●			
95050	95050	17						●		●		
95060	95060	17						●		●		
5130	5130	19						●		●		
5131	5131	19		●					●			
5133	5133	19			●						●	
5150	5150	19				●			●			
602	602	23	●						●			
604	604	23		●						●		
624	624	23			●						●	
6004	6004	27		●						●		
614	614	29			●					●		
670	670	31						●		●		
675	675	31						●		●		
690	690	31						●			●	
695	695	31						●		●		





# PULL ACTION LATCH CLAMPS

## Sizing and Application Chart

**CLICK OR SCAN**  
To view full PDF  
catalog pages on  
these products



Series	Page MC-PAL-#	Max. Holding Capacity N [lbf.]					Plunger Travel mm [inch]				
		0 to 2000 [0 to 450]	2000 to 4000 [450 to 900]	4000 to 6000 [900 to 1350]	6000 to 10000 [1350 to 2250]	10000 to 20000 [2250 to 4500]	20000+ [4500+]	0 to 50 [0 to 1.97]	50 to 75 [1.497 to 2.95]	75 to 100 [2.95 to 3.94]	100 to 125 [3.94 to 4.92]

	3031	1	●						●				
	3051	1			●				●				
	330	3	●						●				
	351	3	●							●			
	371	3		●							●		
	381	3			●							●	
	323	7	●						●				
	331	7		●					●				
	341	7			●				●				
	375	11				●				●			
	385	13					●			●			
	324	16		●					●				
	334	16			●					●			
	344	16			●				●				
	374	16				●			●				
	301	20	●								●		
	311	20			●						●		
	3011	21				●				●			
	353	22			●	—	●			●			



**CLICK OR SCAN**  
To view full PDF  
catalog pages on  
these products

# PULL ACTION LATCH CLAMPS

## Sizing and Application Chart

Overall Height mm [inch]			Overall Length mm [inch]			Overall Width mm [inch]			Standard Material			Hook Style			Service Environment												
0 to 50 [0 to 1.97]	50 to 75 [1.497 to 2.95]	75 to 100 [2.95 to 3.94]	100 to 125 [3.94 to 4.92]	125 to 150 [4.92 to 5.91]	150+ [5.91+]	50 to 100 [1.97 to 3.94]	100 to 150 [3.94 to 5.91]	150 to 200 [5.91 to 7.87]	200 to 250 [5.91 to 9.84]	250 to 300 [5.91 to 11.81]	300 to 350 [11.81 to 13.78]	0 to 40 [0 to 1.57]	40 to 50 [1.57 to 1.97]	50 to 60 [1.97 to 2.36]	60 to 70 [2.36 to 2.76]	70 to 80 [2.76 to 3.15]	80 to 90 [3.15 to 3.54]	Duty Cycle	Steel	Stainless Steel	Toggle Lock Plus™	Fixed	Adjustable U-Hook	Adjustable J-Hook	Normal	Harsh/Dirty	
●								●				○	●					○	✓	✓	✓			✓	✓		
●								●				○	●						○	✓	✓	✓			✓	✓	
●							●					○	●						○	✓	✓	✓			✓	✓	
●	●							●				○	●		●				○	✓	✓	✓			✓	✓	
●	●							●				○	●						○	✓	✓	✓			✓	✓	
●	●							●				○	●						○	✓	✓	✓			✓	✓	
●	●							●				○	●						○	✓	✓	✓			✓	✓	
●	●							●				○	●						○	✓	✓	✓			✓	✓	
●	●							●				○	●						○	✓	✓	✓			✓	✓	
●	●							●				○	●						○	✓	✓	✓			✓	✓	
●	●							●				○	●						○	✓	✓	✓			✓	✓	
●	●							●				○	●						○	✓	✓	✓			✓	✓	
●	●							●				○	●						○	✓	✓	✓			✓	✓	
●	●							●				○	●						○	✓	✓	✓			✓	✓	
●	●							●				○	●						○	✓	✓	✓			✓	✓	
●	●							●				○	●						○	✓	✓	✓			✓	✓	
●	●							●				○	●						○	✓	✓	✓			✓	✓	
●	●							●				○	●						○	✓	✓	✓			✓	✓	
●	●							●				○	●						○	✓	✓	✓			✓	✓	
●	●							●				○	●						○	✓	✓	✓			✓	✓	
●	●							●				○	●						○	✓	✓	✓			✓	✓	
●	●							●				○	●						○	✓	✓	✓			✓	✓	
●	●							●				○	●						○	✓	✓	✓			✓	✓	
●	●							●				○	●						○	✓	✓	✓			✓	✓	
●	●							●				○	●						○	✓	✓	✓			✓	✓	
●	●							●				○	●						○	✓	✓	✓			✓	✓	
●	●							●				○	●						○	✓	✓	✓			✓	✓	
●	●							●				○	●						○	✓	✓	✓			✓	✓	
●	●							●				○	●						○	✓	✓	✓			✓	✓	
●	●							●				○	●						○	✓	✓	✓			✓	✓	
●	●							●				○	●						○	✓	✓	✓			✓	✓	
●	●							●				○	●						○	✓	✓	✓			✓	✓	
●	●							●				○	●						○	✓	✓	✓			✓	✓	
●	●							●				○	●						○	✓	✓	✓			✓	✓	
●	●							●				○	●						○	✓	✓	✓			✓	✓	
●	●							●				○	●						○	✓	✓	✓			✓	✓	
●	●							●				○	●						○	✓	✓	✓			✓	✓	
●	●							●				○	●						○	✓	✓	✓			✓	✓	
●	●							●				○	●						○	✓	✓	✓			✓	✓	
●	●							●				○	●						○	✓	✓	✓			✓	✓	
●	●							●				○	●						○	✓	✓	✓			✓	✓	
●	●							●				○	●						○	✓	✓	✓			✓	✓	
●	●							●				○	●						○	✓	✓	✓			✓	✓	
●	●							●				○	●						○	✓	✓	✓			✓	✓	
●	●							●				○	●						○	✓	✓	✓			✓	✓	
●	●							●				○	●						○	✓	✓	✓			✓	✓	
●	●							●				○	●						○	✓	✓	✓			✓	✓	
●	●							●				○	●						○	✓	✓	✓			✓	✓	
●	●							●				○	●						○	✓	✓	✓			✓	✓	
●	●							●				○	●						○	✓	✓	✓			✓	✓	
●	●							●				○	●						○	✓	✓	✓			✓	✓	
●	●							●				○	●						○	✓	✓	✓			✓	✓	
●	●							●				○	●						○	✓	✓	✓			✓	✓	
●	●							●				○	●						○	✓	✓	✓			✓	✓	
●	●							●				○	●						○	✓	✓	✓			✓	✓	
●	●							●				○	●						○	✓	✓	✓			✓	✓	
●	●							●				○	●						○	✓	✓	✓			✓	✓	
●	●							●				○	●						○	✓	✓	✓			✓	✓	
●	●							●				○	●						○	✓	✓	✓			✓	✓	
●	●							●				○	●						○	✓	✓	✓			✓	✓	
●	●							●				○	●						○	✓	✓	✓			✓	✓	
●	●							●				○	●						○	✓	✓	✓			✓	✓	
●	●							●				○	●						○	✓	✓	✓			✓	✓	
●	●							●				○	●						○	✓	✓	✓			✓	✓	
●	●							●				○	●						○	✓	✓	✓			✓	✓	
●	●							●				○	●						○	✓	✓	✓			✓	✓	
●	●							●				○	●						○	✓	✓	✓			✓	✓	
●	●							●				○	●						○	✓	✓	✓			✓	✓	
●	●							●				○	●						○	✓	✓	✓			✓	✓	
●	●							●				○	●						○	✓	✓	✓			✓	✓	
●	●							●				○	●						○	✓	✓	✓			✓	✓	
●	●							●				○	●						○	✓	✓	✓			✓	✓	
●	●							●				○	●						○	✓	✓	✓			✓	✓	
●	●							●				○	●						○	✓	✓	✓			✓	✓	
●	●							●				○	●						○	✓	✓	✓			✓	✓	
●	●							●				○	●						○	✓	✓	✓			✓	✓	
●	●							●				○	●						○	✓	✓	✓			✓	✓	
●	●							●				○	●						○	✓	✓	✓			✓	✓	
●	●							●				○	●						○	✓	✓	✓			✓	✓	
●	●							●				○	●						○	✓	✓	✓			✓	✓	
●	●							●				○	●						○	✓	✓	✓			✓	✓	
●	●							●				○	●						○	✓	✓	✓			✓	✓	
●	●							●				○	●						○	✓	✓	✓			✓	✓	
●	●																										

# SQUEEZE ACTION PLIER CLAMPS

## Sizing and Application Chart

**CLICK OR SCAN**  
To view full PDF  
catalog pages on  
these products



Series	Page MC-SAP-#	Max. Holding Capacity N [lbf.]					Maximum Clamping Thickness mm [inch]						
		0 to 1000 [0 to 225]	1000 to 2000 [225 to 450]	2000 to 3000 [450 to 675]	3000 to 4000 [675 to 900]	4000 to 5000 [900 to 1125]	5000 to 6000 [1125 to 1350]	0 to 10 [0 to 0.39]	10 to 20 [0.39 to 0.78]	20 to 30 [0.78 to 1.18]	30 to 40 [1.18 to 1.57]	40 to 60 [1.57 to 2.36]	60 to 80 [1.57 to 3.15]
325	1				•					•			
345	2				•								•
424	3	•						•					
441	3		•						•				
431	4	•							•				
462	5				•				•				
463	5				•						•		
482	5								•				
484	5											•	
486	5					•							•

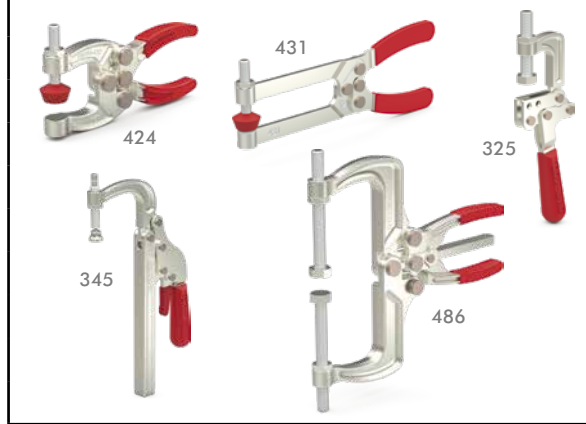



**CLICK OR SCAN**  
To view full PDF  
catalog pages on  
these products

# MANUAL CLAMPING ACCESSORIES

See pages MC-ACC-1 to 10 for more information



# PNEUMATIC TOGGLE CLAMPS

## Sizing and Application Chart

**CLICK OR SCAN**  
To view full PDF  
catalog pages on  
these products



Series	Page MC-PTC-#	Max. Holding Capacity N [lbf.]							Max. Exerting Force at 5bar [72PSI] N [lbf.]						
		0 to 1000 [0 to 225]	1000 to 2000 [225 to 450]	2000 to 3000 [450 to 675]	3000 to 5000 [675 to 1125]	5000 to 7000 [1125 to 1575]	7000 to 10000 [1575 to 2250]	10000+ [2250+]	0 to 1000 [0 to 225]	1000 to 2000 [225 to 450]	2000 to 3000 [450 to 675]	3000 to 4000 [675 to 900]	4000 to 5000 [900 to 1125]	5000 to 6000 [1125 to 1350]	6000 to 8000 [1350 to 1800]

	812	1	●						●						
	802	3	●							●					
	807	5			●						●				
	810	7				●						●			
	846	9				●						●			
	847	11				●							●		
	8007	13				●						●			
	858	15							●						●
	8021	17		●						●					
	8071	17		●							●				
	817	19		●						●					
	827	19				●					●				
	868	21													●
	803	23				●					●				
	8031	24						●				●			
	830	25							●			●			
	850	26							●					●	
	800	27								●					
	1200	27								●					



**CLICK OR SCAN**  
To view full PDF  
catalog pages on  
these products

# PNEUMATIC TOGGLE CLAMPS

## Sizing and Application Chart

Overall Height mm [inch]		Overall Length mm [inch]		Overall Width mm [inch]		Suitable Application Areas				Service Environ- ment																								
0 to 50 [0 to 1.97]	50 to 75 [1.97 to 2.95]	75 to 100 [2.95 to 3.94]	100 to 125 [3.94 to 4.92]	125 to 150 [4.92 to 5.91]	150 to 175 [5.91 to 6.89]	175 to 200 [6.89 to 7.87]	200 to 225 [7.87 to 8.86]	225 to 250 [8.86 to 9.84]	250 to 275 [9.84 to 10.83]	275+ [10.83+]	125 to 150 [4.92 to 5.91]	150 to 175 [5.91 to 6.89]	175 to 200 [6.89 to 7.87]	200 to 225 [7.87 to 8.86]	225 to 250 [8.86 to 9.84]	250 to 300 [9.84 to 11.81]	300 to 400 [11.81 to 15.75]	400+ [15.75+]	20 to 40 [0.78 to 1.57]	40 to 60 [1.57 to 2.36]	60 to 80 [2.36 to 3.15]	80 to 100 [3.15 to 3.94]	100 to 120 [3.94 to 4.72]	Welding	Assembly	Light Machining	Duty Cycle	Accommodates Workpiece Variation	U-Bar Version	Solid Arm Version	Normal	Harsh/Dirty		
●	●	●									●								●	●				●	●	●	●		✓		✓			
	●	●				●							●							●				○	○	○	○		✓		✓			
		●					●						●							●				○	○	○	○		✓	✓	✓			
			●					●						●						●				○	○	○	○		✓	✓	✓			
	●	●											●							●				○	○	○	○				✓		✓	
		●												●						●				○	○	○	○				✓		✓	
●	●										●									●				○	○	○	○	✓					✓	













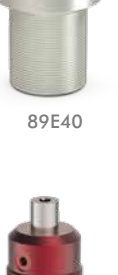





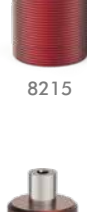

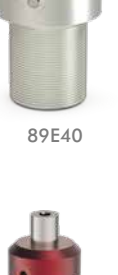
● Excellent/High ○ Fair/Medium ● Poor/Low ⊗ Not Recommended

# PNEUMATIC SWING CLAMPS

## Sizing and Application Chart

CLICK OR SCAN  
To view full PDF  
catalog pages on  
these products

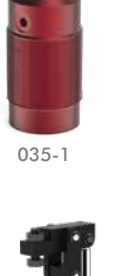

Series	Page MC-PSC-#	Bore Size mm [in]						Total Stroke mm [in]			Clamp Stroke mm [in]		Clamping Force N [lbf]		Arm Rotation - Top of Stroke	Block Body Style	Threaded Body Style	Flanged Body Style	Sensor Ready	360° Arm Adjustability	Clamp Arm/Spindle Incl.	Manual Operation	Confined Space Operation
		Less than 20 [0.79]	20 to 30 [0.79 to 1.18]	30 to 40 [1.18 to 1.57]	40 to 50 [1.57 to 1.97]	50 to 60 [1.97 to 2.36]	60+ [2.36+]	10 to 20 [0.39 to 0.78]	20 to 30 [0.78 to 1.18]	30 to 40 [1.18 to 1.57]	40 to 50 [1.57 to 1.97]	50 to 60 [1.97 to 2.36]	0 to 10 [0 to 0.39]	10 to 20 [0.39 to 0.78]									
	9522-2	1	•				•				•		•		•		✓	✓	✓			✓	
	9530-2	1		•			•				•		•		•		✓	✓	✓			✓	
	9540-2	1			•		•				•		•		•		✓	✓	✓			✓	
	9550-2	1				•	•				•		•		•		✓	✓	✓			✓	
	89R20	6	•				•				•		•		•		✓	✓	✓				
	89R32	6		•			•				•		•		•		✓	✓	✓				
	89R40-010	6			•		•				•		•		•		✓	✓	✓				
	89R40-025	6			•		•			•			•		•		✓	✓	✓				
	89R50	6				•					•		•		•		✓	✓	✓				
	89R63	6					•				•		•		•		✓	✓	✓				
	89B20	12	•				•				•		•		•		✓	✓	✓				
	89B32	12		•			•				•		•		•		✓	✓	✓				
	89B40	12			•		•				•		•		•		✓	✓	✓				
	89B50	12				•		•			•		•		•		✓	✓	✓				
	89B63	12					•				•		•		•		✓	✓	✓				
	8115/8116	17	•				•				•		•		•		✓	✓	✓				
	8315/8316	17			•		•				•		•		•		✓	✓	✓				
	89E20	21	•				•				•		•		•		✓	✓	✓				
	89E32	21		•			•				•		•		•		✓	✓	✓				
	89E40	21			•		•				•		•		•		✓	✓	✓				
	89E50	21				•		•			•		•		•		✓	✓	✓				
	89E63	21					•				•		•		•		✓	✓	✓				
	8015/8016	26	•				•				•		•		•		✓	✓	✓				
	8215/8216	26			•		•				•		•		•		✓	✓	✓				
	8415/8416	26				•					•		•		•		✓	✓	✓				
	035-125	30	•				•				•		•		•		✓	✓	✓				
	035-132	30		•			•				•		•		•		✓	✓	✓				
	035-140	30			•		•				•		•		•		✓	✓	✓				
	035-150	30				•					•		•		•		✓	✓	✓				
	035-225	30	•				•				•		•		•		✓	✓	✓				
	035-232	30		•			•				•		•		•		✓	✓	✓				
	035-240	30			•		•				•		•		•		✓	✓	✓				
	035-250	30				•					•		•		•		✓	✓	✓				
	8725	35	•				•				•		•		•		✓	✓	✓				
	8732	35		•			•				•		•		•		✓	✓	✓				
	8740	35			•		•				•		•		•		✓	✓	✓				
	8750	35					•				•		•		•		✓	✓	✓				
	6004-SW	40			N/A			•			•		•		•		✓	✓	✓				





**CLICK OR SCAN**  
To view full PDF  
catalog pages on  
these products

# PNEUMATIC POWER CYLINDERS

See pages MC-PPC-1 to 12 for more information



**CLICK OR SCAN**  
To view full PDF  
catalog pages on  
these products

# HYDRAULIC POWER CLAMPS

See pages MC-HYD-1 to 14 for more information



# PNEUMATIC POWER CLAMPS

## Sizing and Application Chart

CLICK OR SCAN  
To view full PDF  
catalog pages on  
these products



Series	Page PC-PPC-#	Holding Torque at 5 bar Nm					Clamping Torque at 5 bar Nm					Piston Diameter mm						
		0 to 100	100 to 500	500 to 1000	1000 to 2000	2000 to 4000	0 to 100	100 to 500	500 to 1000	1000 to 2000	2000 to 4000	Less than 25	25	32	40	50	63	80
81L	1	●					●					●						
82L-4	5	●					●					●	●					
82L-2	15	●	●				●	●				●	●	●				
TCC-2	25	●					●								●	●		
82M-3E	28		●		●	●		●	●						●	●	●	
52H-3E	53				●													
870/871	63		●				●								●			
860/861	65			●				●								●		
890/891	65				●			●									●	
1000/1001	65				●				●								●	●
82D	67		●				●	●							●		●	
84A	75	●	●				●	●							●	●		



# 2002 SERIES

## Vertical Hold Down Clamps | Product Overview

### Features:

- Large hand clearance for improved safety
- Bolt pattern interchangeable with 202 Series
- Three times the holding capacity of 202 Series
- Hardened bushings at key pivot points
- Near vertical clamping contact
- BLK models feature a black, non-reflective finish

### Applications:

- Checking fixtures
- Assembly & test
- Light machining
- Woodworking

### Also Available:

See page MC-ACC-1 for accessories  
Accepts M6 or 1/4 spindle accessories

Covered under one or more U.S./International Patents

**2002-U/USS**  
Flanged Base  
U-Bar



-USS Stainless Steel Model



**2002-U-LS-BLK** ⓘ  
Blackout Series  
Flanged Base  
U-Bar



**2002-S**  
Flanged Base  
Solid Bar



**2002-UB**  
Straight Base  
U-Bar



**2002-UB-LS-BLK** ⓘ  
Blackout Series  
Straight Base  
U-Bar



**2002-SB**  
Straight Base  
Solid Bar



**2002-UR/URSS**  
Flanged Base  
U-Bar  
DESTACO®  
Toggle Lock Plus



-URSS Stainless Steel Model



**2002-SR** ⓘ  
Flanged Base  
Solid Bar  
DESTACO®  
Toggle Lock Plus



**2002-UBR**  
Straight Base  
U-Bar  
DESTACO®  
Toggle Lock Plus



**2002-SBR** ⓘ  
Straight Base  
Solid Bar  
DESTACO®  
Toggle Lock Plus



**2002-U207**  
Flanged Base  
U-Bar  
Interchangeable  
with 207 Series



**2002-UR207**  
Flanged Base  
U-Bar  
Interchangeable  
with 207 Series  
DESTACO®  
Toggle Lock Plus



ⓘ This item is available upon request

# 2002 SERIES

## Vertical Hold Down Clamps | Technical Information

Model	Max. Holding Capacity	Clamp Bar Opening(+10°)	Handle Opening (+10°)	Weight	Accessories (Supplied)				
					Bolt Retainer	Spindle Assembly	Flanged Washers		
2002-U	2700 N [600 lbf]	75°	66°	0,22 kg [0.48 lb]	--	215208-M	215105		
2002-USS					--	202943-M	215905		
2002-U-LS-BLK ⓘ					--	--	215105-BLK		
2002-S					2002115-E	--	--		
2002-UB					--	215208-M	215105		
2002-UB-LS-BLK ⓘ					--	--	215105-BLK		
2002-SB				2002115-E	--	--			
2002-UR				--	215208-M	215105			
2002-URSS				--	202943-M	215905			
2002-SR ⓘ				2002115-E	--	--			
2002-UBR				--	215208-M	215105			
2002-SBR ⓘ				2002115-E	--	--			
2002-U207				90°	72°	0,26 kg [0.57 lb]	--	215208-M	215105
2002-UR207				75°	57°				

ⓘ This item is available upon request

## Holding Capacities

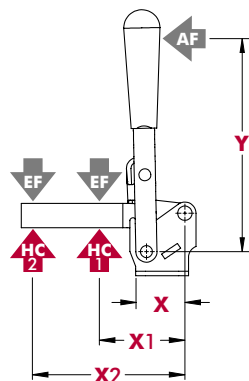

Model	X	X1	X2	Y	±HC1	±HC2	±EF(X1):AF	±EF(X2):AF
2002-( )	[1.12] 28,5	[1.45] 37	[2.64] 67	[3.66] 93	[600 lbf] 2700 N	[295 lbf] 1310 N	11:1	5:1

Dimensions shown "mm [inch]" ± HC = Holding Capacity, EF = Exerting Force, AF = Applied Force  
See page MC-TEC-4 for additional information.





# 2007 SERIES

## Vertical Hold Down Clamps | Product Overview

### Features:

- Large hand clearance for improved safety
- Bolt pattern interchangeable with 207 Series
- Over two times the holding capacity of 207 Series
- Hardened bushings at key pivot points
- Near vertical clamping contact

### Applications:

- Checking fixtures
- Assembly & test
- Light machining
- Woodworking

### Also Available:

See page MC-ACC-1 for accessories  
Accepts M8 or 5/16 spindle accessories

Covered under one or more U.S./International Patents

**2007-U/USS**  
Flanged Base  
U-Bar



-USS Stainless Steel Model



**2007-U-LS-BLK** ⓘ  
Blackout Series  
Flanged Base  
U-Bar



**2007-S**  
Flanged Base  
Solid Bar



**2007-UB**  
Straight Base  
U-Bar



**2007-UB-LS-BLK** ⓘ  
Blackout Series  
Straight Base  
U-Bar



**2007-SB**  
Straight Base  
Solid Bar



**2007-UR/URSS**  
Flanged Base  
U-Bar  
DESTACO®  
Toggle Lock Plus



-URSS Stainless Steel Model



**2007-SR** ⓘ  
Flanged Base  
Solid Bar  
DESTACO®  
Toggle Lock Plus



**2007-UBR**  
Straight Base  
U-Bar  
DESTACO®  
Toggle Lock Plus



**2007-SBR** ⓘ  
Straight Base  
Solid Bar  
DESTACO®  
Toggle Lock Plus



## Technical Information

Model	Max. Holding Capacity	Clamp Bar Opening (+10°)	Handle Opening (+10°)	Weight	Accessories (Supplied)		
					Bolt Retainer	Spindle Assembly	Flanged Washers
2007-U	4450 N [1000 lbf]	76°	64°	0,54 kg [1.20 lbs]	--	2007208-M	507107
2007-USS					--	207943-M	507907
2007-U-LS-BLK ⓘ					--	--	507107-BLK
2007-S					2007115-E	--	--
2007-UB					--	2007208-M	507107
2007-UB-LS-BLK ⓘ					--	--	507107-BLK
2007-SB					2007115-E	--	--
2007-UR					--	2007208-M	507107
2007-URSS					--	207943-M	507907
2007-SR ⓘ					2007115-E	--	--
2007-UBR	--	2007208-M	507107				
2007-SBR ⓘ	2007115-E	--	--				

ⓘ This item is available upon request



## Vertical Hold Down Clamps | Holding Capacities

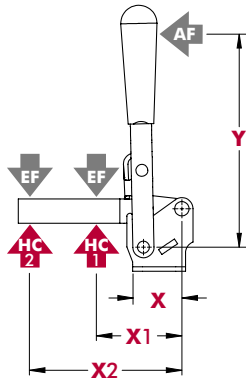

Model	X	X1	X2	Y	±HC1	±HC2	±EF(X1):AF	±EF(X2):AF
2007-( )	[1.59] 40,5	[1.95] 49,5	[3.92] 99,5	[5.16] 131	[1000 lbf] 4450 N	[470 lbf] 2090 N	10:1	5.3:1

Dimensions shown "mm [inch]" ± HC = Holding Capacity, EF = Exerting Force, AF = Applied Force  
See page MC-TEC-4 for additional information.

## Dimensions | -U/-USS/-S/-UB/-SB/-UR/-URSS/-SR/-UBR/-SBR

### 2007-U Flanged Base U-Bar

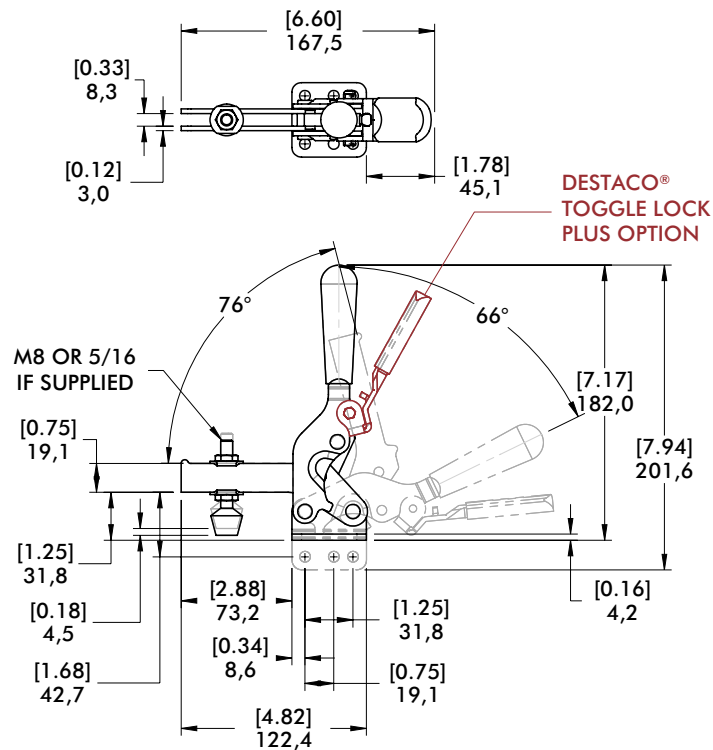
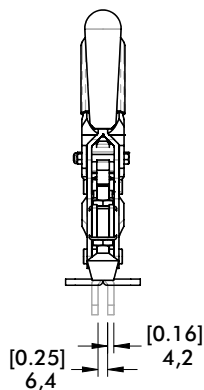

### 2007-SB Straight Base Solid Bar

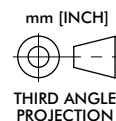
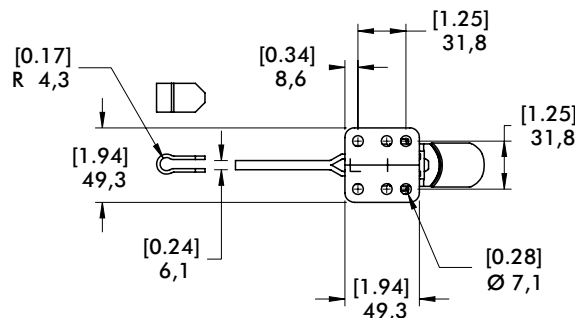

# 2010 SERIES

## Vertical Hold Down Clamps | Product Overview

### Features:

- Large hand clearance for improved safety
- Bolt pattern interchangeable with 210 Series
- Over two times the holding capacity of 210 Series
- Hardened bushings at key pivot points
- Near vertical clamping contact

### Applications:

- Checking fixtures
- Assembly & test
- Light machining
- Woodworking

### Also Available:

See page MC-ACC-1 for accessories  
Accepts M10 or 3/8 spindle accessories

Covered under one or more U.S./International Patents

**2010-U**  
Flanged Base  
U-Bar



**2010-S**  
Flanged Base  
Solid Bar



**2010-UB**  
Straight Base  
U-Bar



**2010-SB**  
Straight Base  
Solid Bar



**2010-UR**  
Flanged Base  
U-Bar  
DESTACO®  
Toggle Lock  
Plus



**2010-SR<sup>ⓘ</sup>**  
Flanged Base  
Solid Bar  
DESTACO®  
Toggle Lock  
Plus



**2010-UBR**  
Straight Base  
U-Bar  
DESTACO®  
Toggle Lock  
Plus



**2010-SBR<sup>ⓘ</sup>**  
Straight Base  
Solid Bar  
DESTACO®  
Toggle Lock  
Plus

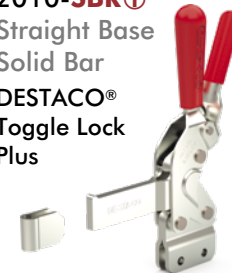

## Technical Information

Model	Max. Holding Capacity	Clamp Bar Opening (+10°)	Handle Opening (+10°)	Weight	Accessories (Supplied)		
					Bolt Retainer	Spindle Assembly	Flanged Washers
2010-U	6230 N [1400 lbf]	78°	66°	1,16 kg [2.56 lbs]	---	240208-M	235106
2010-S					2010115-E	---	
2010-UB					---	240208-M	235106
2010-SB					2010115-E	---	
2010-UR					---	240208-M	235106
2010-SR <sup>ⓘ</sup>					2010115-E	---	
2010-UBR					---	240208-M	235106
2010-SBR <sup>ⓘ</sup>					2010115-E	---	

<sup>ⓘ</sup> This item is available upon request

# 2010 SERIES

## Vertical Hold Down Clamps | Holding Capacities

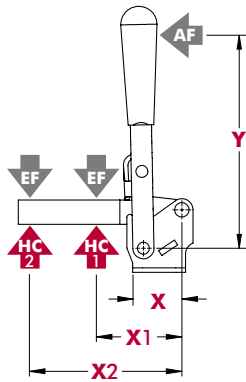

Model	X	X1	X2	Y	±HC1	±HC2	±EF(X1):AF	±EF(X2):AF
2010-( )	[2.04] 51,8	[2.44] 62	[4.88] 124	[7.00] 178	[1400 lbf] 6230 N	[720 lbf] 3200 N	13:1	6:1

Dimensions shown "mm [inch]" ± HC = Holding Capacity, EF = Exerting Force, AF = Applied Force  
See page MC-TEC-4 for additional information.

## Dimensions | -U/-S/-UB/-SB/-UR/-SR/-UBR/-SBR

**2010-U**  
Flanged Base  
U-Bar

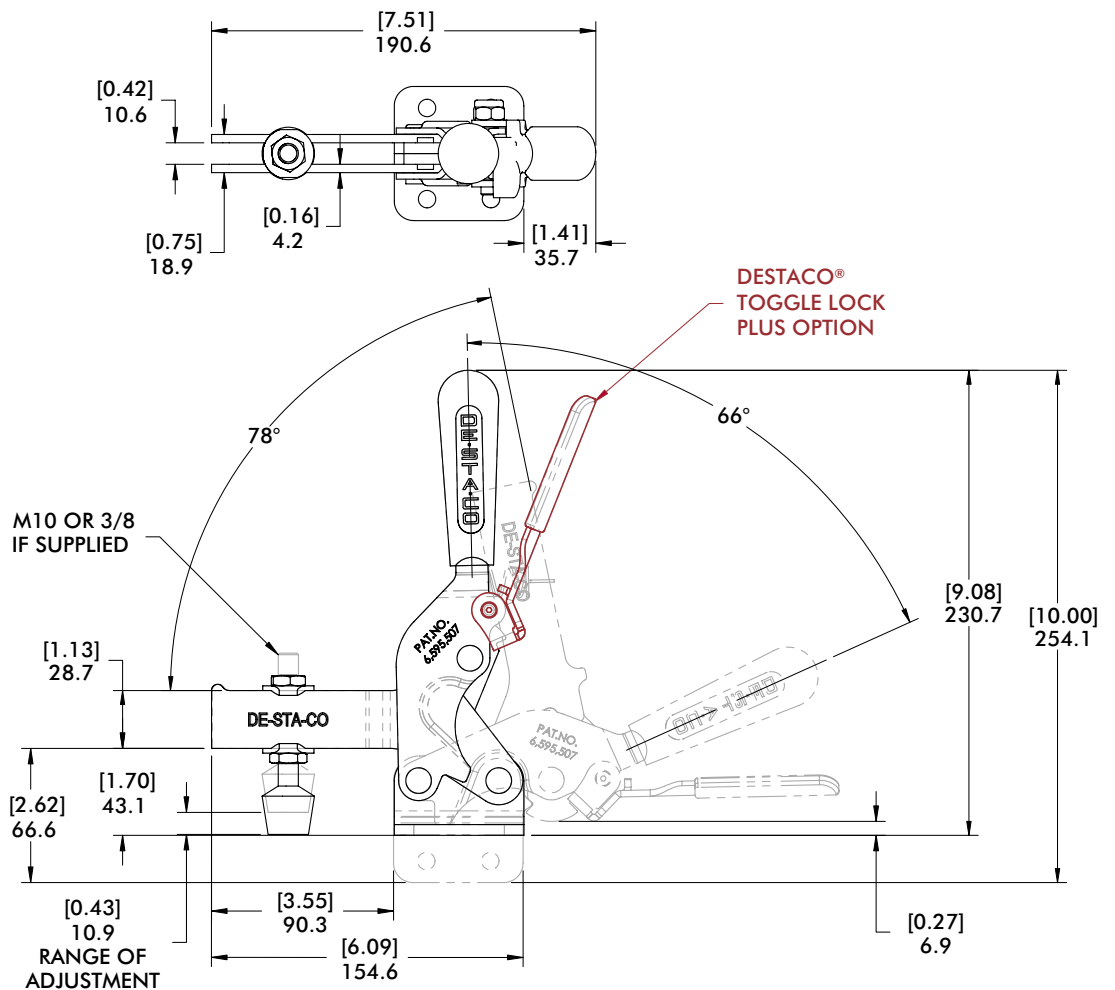

**2010-SB**  
Straight Base  
Solid Bar

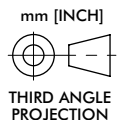
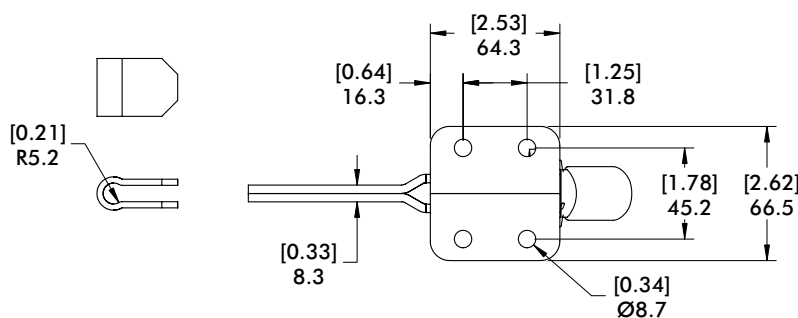

# 201 SERIES

## Vertical Hold Down Clamps | Product Overview

### Features:

- Smallest series in the Vertical Handle series
- Stainless steel version available

### Applications:

- Checking fixtures
- Assembly & test
- Woodworking

### Also Available:

See page MC-ACC-1 for accessories

812-U Pneumatic Toggle Clamp  
(See page MC-PTC-1)

**201-U/USS**  
Flanged Base  
U-Bar



-USS Stainless  
Steel Model



**201-UB**  
Straight Base



**201-TU**  
Flanged Base  
U-Bar  
T-Handle



## Technical Information

Model	Max. Holding Capacity	Clamp Bar Opening (+10°)	Handle Opening (+10°)	Weight	Accessories (Supplied)	
					Spindle Assembly	Flanged Washers
201-U	440 N [100 lbf]	100°	55°	0,70 kg [0.15 lbs]	305208-M	102111
201-UB						
201-TU						
201-USS	560 N [125 lbf]				201943-M	102911

## Holding Capacities

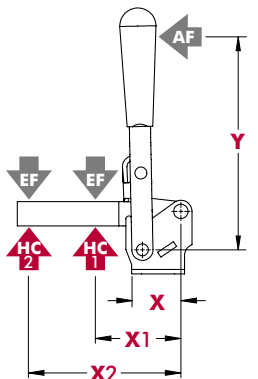

Model	X	X1	X2	Y	‡HC1	‡HC2	‡EF(X1):AF	‡EF(X2):AF
U/UB				[2.25] 57	[100 lbf]	[55 lbf]	9:1	6:1
TU	[0.87] 22	[1.06] 27	[1.75] 44,5	[1.38] 35	440 N	245 N	8.4:1	4:4:1
USS				[2.25] 57	[125 lbf] 560 N	[60 lbf] 270 N	9:1	6:1

Dimensions shown "mm [inch]" ‡ HC = Holding Capacity, EF = Exerting Force, AF = Applied Force  
See page MC-TEC-4 for additional information.

**201-U**  
Flanged Base  
U-Bar

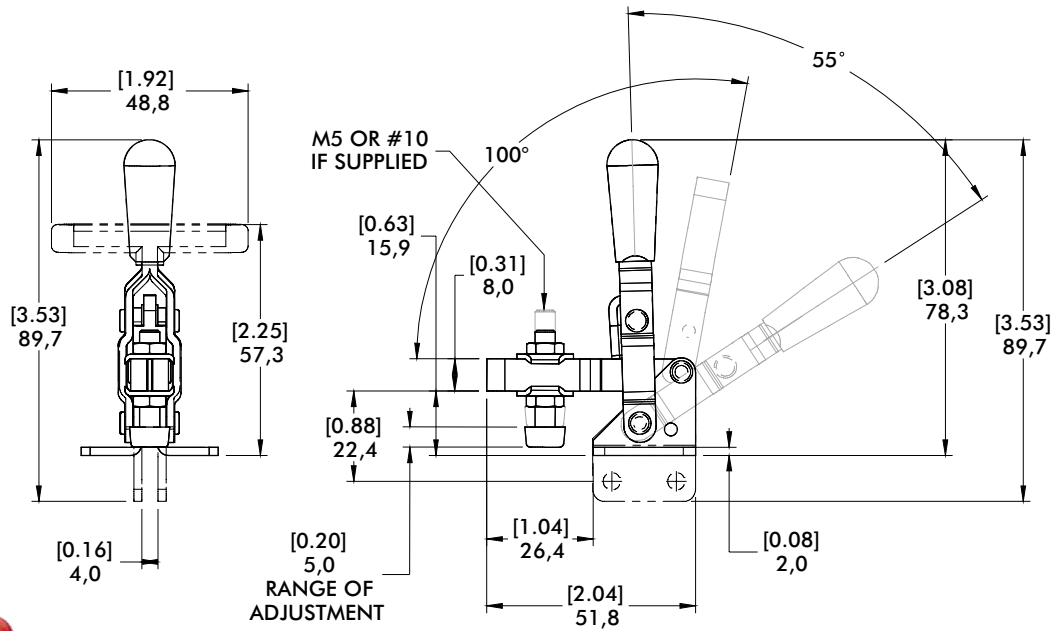
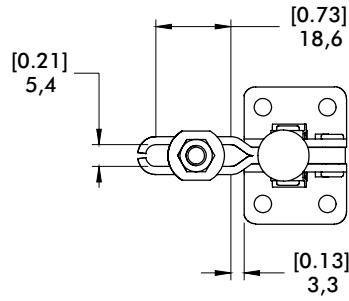

**201-UB**  
Straight Base

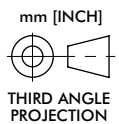
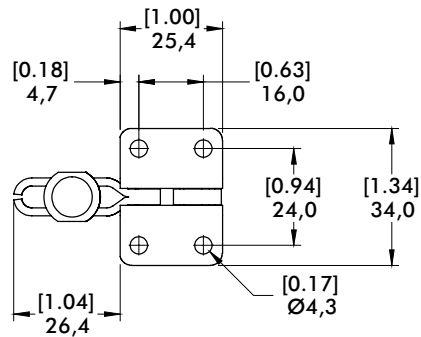

# 202 SERIES

## Vertical Hold Down Clamps | Product Overview

### Features:

- Two bar styles available
- Low profile T-Handle version available
- Available in stainless steel
- Accommodates M6 or 1/4" spindle accessories
- BLK models feature a black, non-reflective finish

### Applications:

- Checking fixtures
- Assembly & test
- Light machining
- Woodworking

### Also Available:

See page MC-ACC-1 for accessories

802-U Pneumatic Toggle Clamp  
(See page MC-PTC-3)

**202-U/USS**  
Flanged Base  
U-Bar



-**USS** Stainless  
Steel Model



**202-UL**  
Flanged Base  
Long U-Bar



**202/-SS**  
Flange Base  
Solid Bar



-**SS** Stainless  
Steel Model



**202-UB**  
Straight Base  
U-bar



**202-B**  
Straight Base  
Solid Bar



**202-TU**  
Flanged Base  
U-bar,  
T-Handle



**202-T**  
Flanged Base  
Solid Bar  
T-Handle



**202-U-L** ⓘ  
Flanged Base  
Open U-Bar



**202-U-L-BLK** ⓘ  
Blackout Series  
Flanged Base  
Open U-Bar



**202-UB-L** ⓘ  
Straight Base  
Open U-Bar



**202-UB-L-BLK** ⓘ  
Blackout Series  
Straight Base  
Open U-Bar



**202305**  
Flanged Grip.  
Provides added safety  
and protection. Fits all  
202 Series (except  
T-Handle) clamps.  
Order separately.



ⓘ This item is available upon request

Model	Max. Holding Capacity	Clamp Bar Opening (+10°)	Handle Opening (+10°)	Weight	Accessories (Supplied)		
					Spindle Assembly	Flanged Washers	
202-U	890 N [200 lbf]	105°	65°	0,16 kg [0.35 lbs]	202208-M	215105	
202-UL	890 N [200 lbf]				202943-M	215905	
202-USS	1110 N [250 lbf]			202208-M	---		
202	890 N [200 lbf]			205943-M	---		
202-SS	1110 N [250 lbf]			0,16 kg [0.35 lbs]	202208-M	215105	
202-UB	890 N [200 lbf]			0,15 kg [0.33 lbs]			
202-B	890 N [200 lbf]			0,17 kg [0.38 lbs]			
202-TU	890 N [200 lbf]			0,16 kg [0.35 lbs]			
202-U-L ⓘ						---	---
202-U-L-BLK ⓘ							
202-UB-L ⓘ							
202-UB-L-BLK ⓘ							

ⓘ This item is available upon request

### Holding Capacities

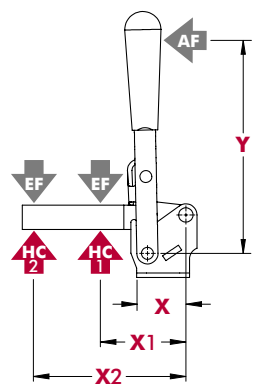

Model	X	X1	X2	Y	±HC1	±HC2	±EF(X1):AF	±EF(X2):AF
202-U			[2.25] 57	[3.42] 87	[200 lbf] 890 N	[140 lbf] 625 N		5:1
202-UL		[1.25] 32	[2.88] 73			[150 lbf] 670 N	10:1	4:1
202-USS			[2.25] 57	[3.00] 76	[250 lbf] 1110 N	[170 lbf] 760 N		5:1
202			[1.88] 48	[3.42] 87	---	[200 lbf] 890 N	---	8:1
202-SS				[3.00] 76	---	[250 lbf] 1110 N		
202-UB		[1.25] 32	[2.25] 57	[3.42] 87	[200 lbf] 890 N	[140 lbf] 625 N	10:1	5:1
202-B	[0.79] 20		[1.88] 48		---	[200 lbf] 890 N	---	8:1
202-TU		[1.25] 32	[2.25] 57	[2.13] 54	[200 lbf] 890 N	[140 lbf] 625 N	11:1	7:1
202-T			[1.88] 48		---	[200 lbf] 890 N	---	6:1
202-U-L ⓘ								
202-U-L-BLK ⓘ								
202-UB-L ⓘ		[1.25] 32	[2.25] 57	[3.42] 87	[200 lbf] 890 N	[140 lbf] 625 N	10:1	5:1
202-UB-L-BLK ⓘ								

Dimensions shown "mm [inch]" ± HC = Holding Capacity, EF = Exerting Force, AF = Applied Force

ⓘ This item is available upon request

# 202 SERIES

## Vertical Hold Down Clamps | Dimensions | -U/-UL/-USS/-SS/-UB/-B/-TU/-T

**202-U**  
Flanged Base  
U-Bar

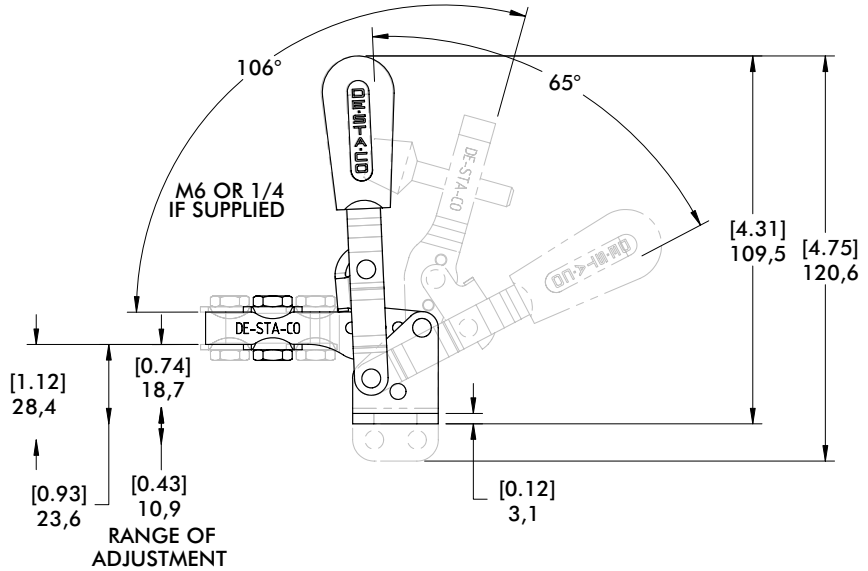
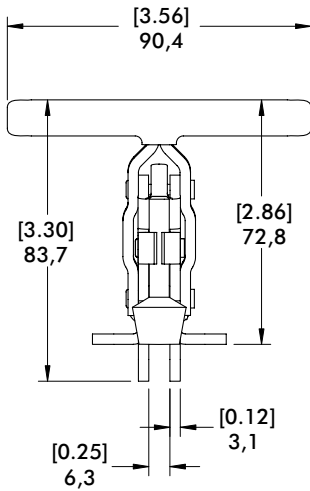
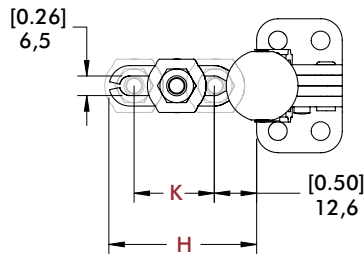

### Open Bar Option



See page  
MC-ACC-7  
for complete  
offering of open  
bar accessories

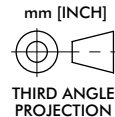
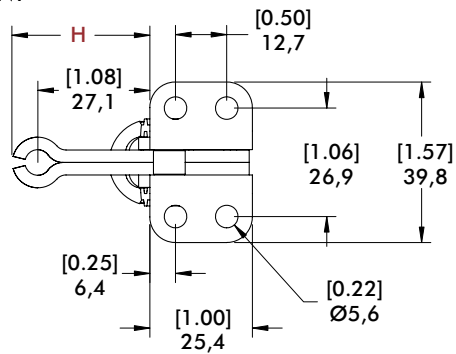

Flanged Base  
**Model**

202-U-L ⓘ  
202-U-L-BLK ⓘ

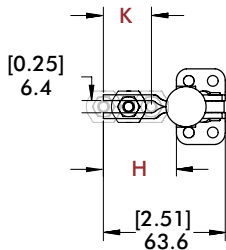

Straight Base  
**Model**

202-UB-L ⓘ  
202-UB-L-BLK ⓘ

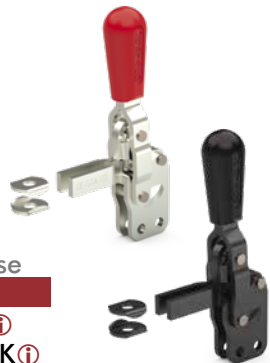

Bar Style	Clamp Models	H	K
	202-U/202-UB/ 202-USS/202-TU	[1.73] 43,9	[0.98] 25
	202-UL ⓘ	[2.29] 58,1	[1.51] 38,4
	202/202-B/ 202-T/202-SS	[1.31] 33,3	---
	202-U-L ⓘ/ 202-UB-L ⓘ	[1.50] 38,1	[0.99] 25,1

ⓘ This item is available upon request



# VERTICAL HOLD DOWN CLAMPS

## Application Example

### Application Areas

Clamping during the assembling, drilling, testing, gluing, locking of covers and much more. The vertical clamp is the most frequently used product whenever clamping products are to be integrated with a manual fixture.

### The essential product features

- In the clamping position, the handle is vertical
- Vertical clamps open at an angle between 75° and 215°
- Vertical clamps are offered with U-shaped or heavy-duty solid clamping bars
- Vertical clamps have a straight or flanged base.  
The heavy-duty vertical clamps possess a base that can be welded on without a hole pattern



# 207 SERIES

## Vertical Hold Down Clamps | Product Overview

### Features:

- Largest selection of arm and mounting options
- Low profile T-Handle version available
- Available in stainless steel
- BLK models feature a black, non-reflective finish

### Applications:

- Checking fixtures
- Assembly & test
- Light machining
- Woodworking

### Also Available:

See page MC-ACC-1 for accessories

**807-U** Pneumatic toggle clamp  
(See page MC-PTC-6)

**807-S** Pneumatic toggle clamp  
(See page MC-PTC-6)

Accepts M8 or 5/16 spindle accessories

**207-U**  
Flanged Base  
U-Bar



-**USS** Stainless  
Steel Model



**207-UL**  
Flanged Base  
Long U-Bar



**207-S**  
Flanged Base  
Solid Bar



**207-L**  
Flanged Base  
Long Solid Bar



**207-TU**  
Flanged Base  
T-Handle  
U-Bar



**207-TUL**  
Flanged Base  
T-Handle  
Long U-Bar



**207-UR**  
Flanged Base  
U-Bar  
**DESTACO®**  
Toggle Lock  
Plus



**207-LR**  
Flanged Base  
Long Solid Bar  
**DESTACO®**  
Toggle Lock  
Plus



**207-UB**  
Straight Base  
U-Bar



**207-ULB**  
Straight Base  
Long U-Bar



**207-SB**  
Straight Base  
Solid Bar



**207-LB**  
Straight Base  
Long Solid  
Bar



**207-LBR** ⓘ  
Straight Base  
Long Solid Bar  
**DESTACO®**  
Toggle Lock  
Plus



**207-UF** ⓘ  
U-Bar  
Dual Mount



**207-SF** ⓘ  
Solid Bar  
Dual Mount



**207-U-L** ⓘ  
Flange Base  
Open Bar



**207-U-L-BLK**  
Blackout Series  
Flanged Base  
Open U-Bar



**207-UB-L** ⓘ  
Straight Base  
Open Bar



**207-UB-L-BLK**  
Blackout Series  
Straight Base  
Open U-Bar



### 207305

Flanged Grip. Provides added safety and protection. Fits all 207 Series (except T-Handle) clamps. Order separately.



ⓘ This item is available upon request

Model	Max. Holding Capacity	Clamp Bar Opening (+10°)	Handle Opening (+10°)	Weight	Accessories (Supplied)						
					Bolt Retainer	Spindle Assembly	Flanged Washers				
207-U	1670 N [375 lbf]	99°	57°	0,30 kg [0.67 lb]	---	225208-M	507107				
207-UR				0,45 kg [1.00 lb]							
207-UL				0,30 kg [0.67 lb]							
207-USS	2000 N [450 lbf]			---	207943-M	507907					
207-S	2220 N [500 lbf]			99°	57°	0,31 kg [0.69 lb]	207105	---	---		
207-L						0,34 kg [0.74 lb]					
207-LR						0,45 kg [1.00 lb]					
207-UB	1670 N [375 lbf]			99°	57°	0,33 kg [0.72 lb]	---	225208-M	507107		
207-ULB						0,31 kg [0.69 lb]					
207-SB	2220 N [500 lbf]					99°	57°	0,31 kg [0.69 lb]	207105	---	---
207-LB								0,34 kg [0.75 lb]			
207-LBR ⓘ								0,45 kg [1.00 lb]			
207-TU	1670 N [375 lbf]					99°	57°	0,33 kg [0.72 lb]	---	---	507107
207-TUL								0,38 kg [0.84 lb]			---
207-UF ⓘ	1670 N [375 lbf]							96°	56°	0,43 kg [0.94 lb]	---
207-SF ⓘ	2220 N [500 lbf]	90°	56°					0,38 kg [0.84 lb]	207105	---	---
207-U-L ⓘ	1670 N [375 lbf]	99°	57°					0,38 kg [0.84 lb]	---	---	507107
207-U-L-BLK ⓘ											507107-BLK
207-UB-L ⓘ											507107
207-UB-L-BLK ⓘ											507107-BLK

ⓘ This item is available upon request

### Holding Capacities

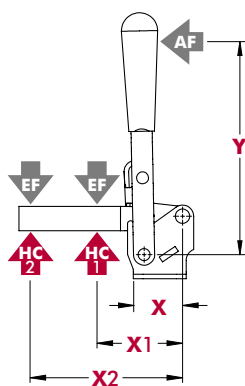

Model	X	X1	X2	Y	±HC1	±HC2	±EF(X1):AF	±EF(X2):AF
U/UB/UR	[1.28] 32,6	[2.00] 50,8	[3.75] 95,3	[4.90] 124,5	[375 lbf] 1670 N	[225 lbf] 1000 N	12:1	6:1
UL/ULB		[3.88] 98,5	[5.00] 127		[150 lbf] 670 N	7:1	4:1	
USS		[2.00] 50,8	[3.75] 95,3		[450 lbf] 2000 N	[240 lbf] 1070 N	5:1	
S/SB		[2.88] 73,0	[5.00] 127	[3.66] 9	[500 lbf] 2220 N	[350 lbf] 1560 N	10:1	7:1
L/LR LB/LBR		[2.88] 73,0	[5.00] 127		[375 lbf] 1670 N	[225 lbf] 1000 N	6:1	4:1
TU		[2.00] 50,8	[3.75] 95,3	[375 lbf] 1670 N	[150 lbf] 670 N	4:1	3:1	
TUL		[3.88] 98,5	[5.00] 127	[375 lbf] 1670 N	[225 lbf] 1000 N	6:1	4:1	
U-L		[2.00] 50,8	[3.75] 95,3	[4.90] 124,5	[375 lbf] 1670 N	[2225 lbf] 1000 N	12:1	6:1
UB-L		[2.00] 50,8	[3.75] 95,3	[4.90] 124,5	[375 lbf] 1670 N	[2225 lbf] 1000 N	12:1	6:1

Dimensions shown "mm [inch]" ± HC = Holding Capacity, EF = Exerting Force, AF = Applied Force

# 207 SERIES

Vertical Hold Down Clamps | Dimensions | -U/-UL/-S/-L/-TU/-TUL/-UR/-LR/-UB/-ULB/-SB/-LB/-LBR

## 207-U Flanged Base U-Bar

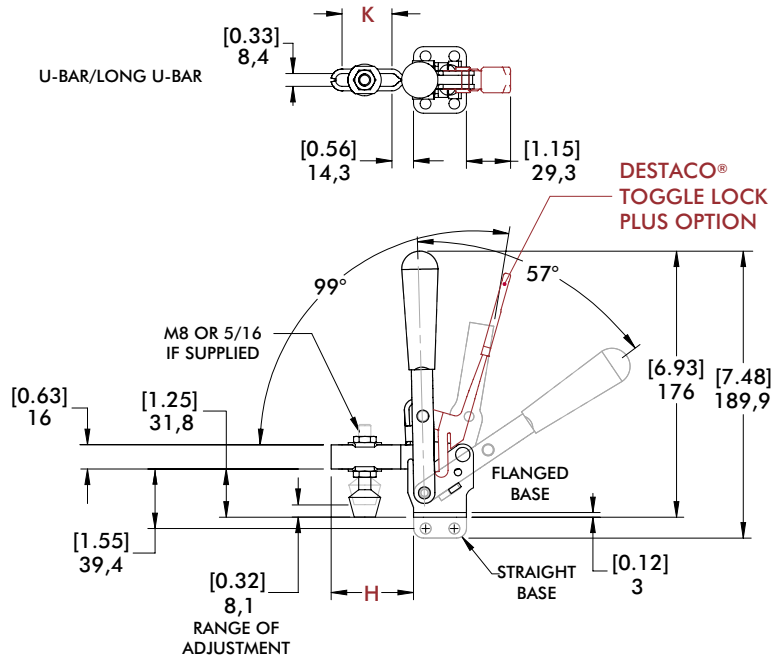
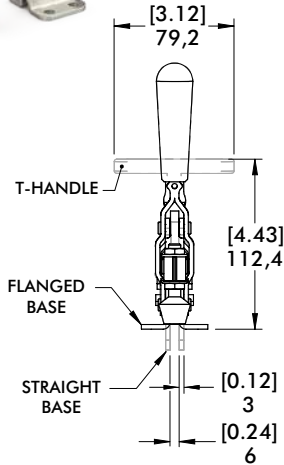

## 207-SB Straight Base Solid Bar

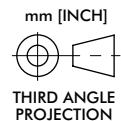
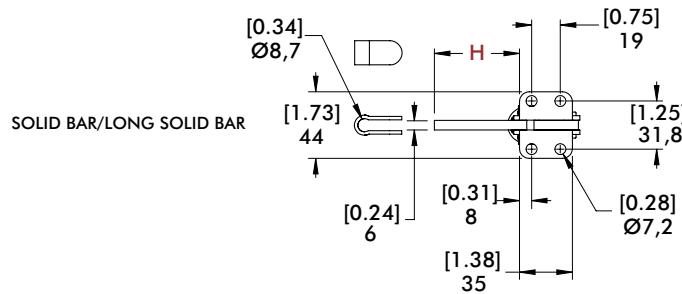

Bar Style	Clamp Models	H	K
	207-U/207-UR/207-TU/207-UB	[2.14] 54,4	[1.30] 33
	207-UL/207-ULB/207-TUL	[3.84] 97,6	[2.94] 74,6
	207-S/207-SB	[2.21] 56,2	---
	207-L/207-LR/207-LB/207-LBR ⓘ	[3.48] 88,4	---

ⓘ This item is available upon request

# 207 SERIES

## Vertical Hold Down Clamps | Dimensions | Dual Mount

**Model**  
207-SF ⓘ

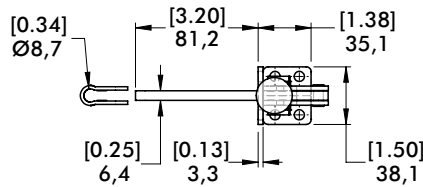
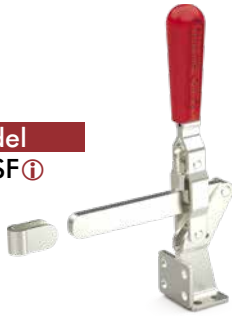

**Model**  
207-UF ⓘ

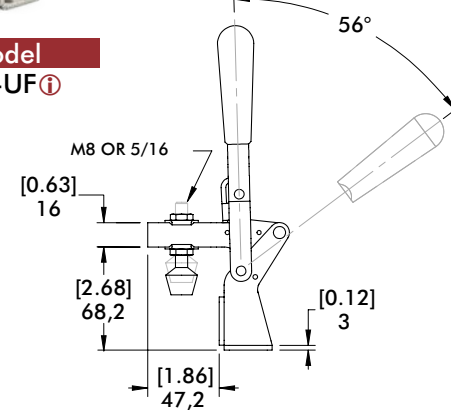
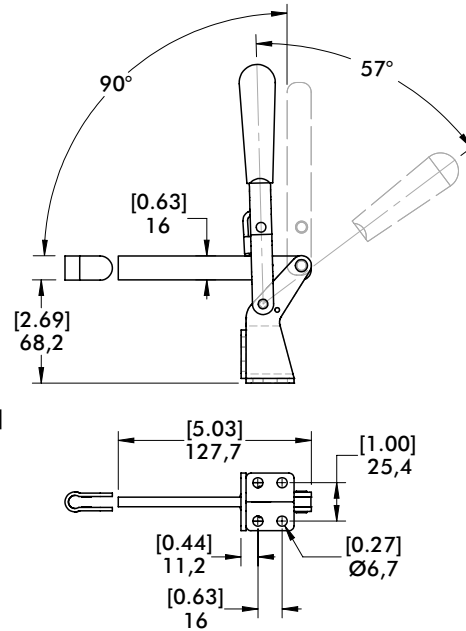
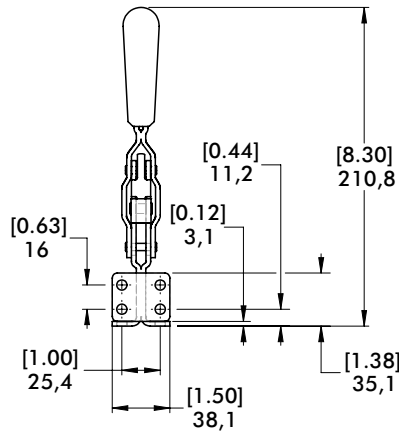
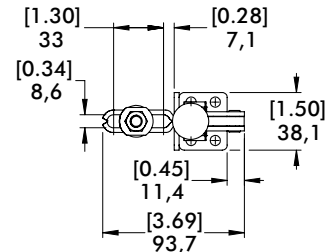

ⓘ This item is available upon request

### Open Bar Option

See page MC-ACC-7 for Complete offering of Open bar accessories

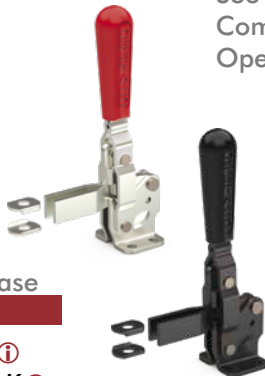

**Flanged Base**  
**Model**

207-U-L ⓘ  
207-U-L-BLK ⓘ

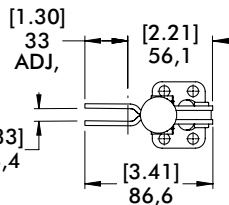

### Stainless Steel



**Model**  
207-USS

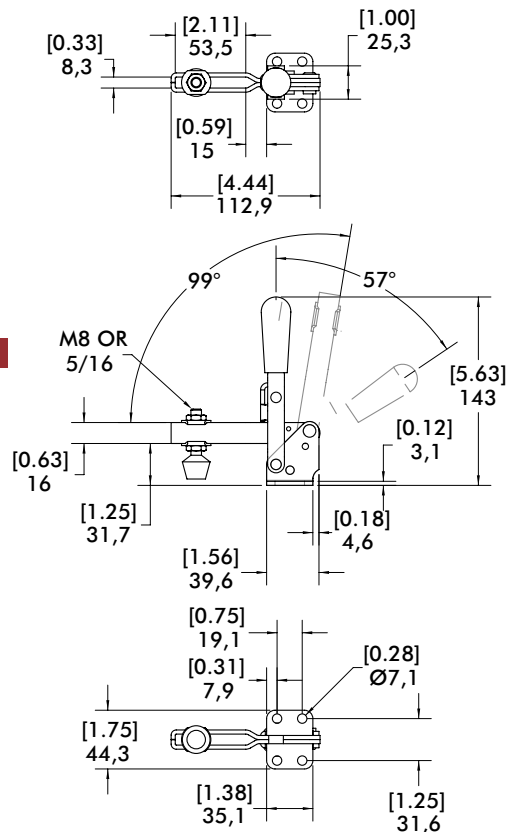

**Straight Base**  
**Model**

207-UB-L ⓘ  
207-UB-L-BLK ⓘ

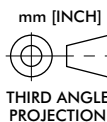

# 210 SERIES

## Vertical Hold Down Clamps | Product Overview

### Features:

- DESTACO® Toggle Lock Plus™ versions available
- Available in stainless steel
- Accommodates M10 or 3/8 spindle accessories

### Applications:

- Assembly & test
- Light machining
- Light welding

### Also Available:

See page MC-ACC-1 for accessories  
 810-U Pneumatic Toggle Clamp  
 (See page MC-PTC-7)  
 810-S Pneumatic Toggle Clamp  
 (See page MC-PTC-7)

**210-U/USS**  
 Flanged Base  
 U-Bar



-USS Stainless  
 Steel Model



**210-S**  
 Flanged Base  
 Solid Bar



**210-UB**  
 Straight Base  
 U-bar



**210-SB**  
 Straight Base  
 Solid Bar



**210-UR**  
 Flanged Base  
 U Bar  
 DESTACO®  
 Toggle Lock  
 Plus



**210-SR**  
 Flanged Base  
 Solid Bar  
 DESTACO®  
 Toggle Lock  
 Plus



**210-TU**  
 Flanged Base  
 U Bar  
 T-Handle



## Technical Information

Model	Max. Holding Capacity	Clamp Bar Opening (+10°)	Handle Opening (+10°)	Weight	Accessories (Supplied)		
					Bolt Retainer	Spindle Assembly	Flanged Washers
210-U	2670 N [600 lbf]	103°	58°	0,59 kg [1.29 lbs]	---	240208-M	235106
210-USS	3340 N [750 lbf]				---	237943-M	235906
210-S					210114	237943-M	---
210-UB	2670 N [600 lbf]				---	240208-M	235106
210-SB	3340 N [750 lbf]			210114	---	---	
210-UR	2670 N [600 lbf]			---	240208-M	235106	
210-SR	3340 N [750 lbf]			210114	---	---	
210-TU	2670 N [600 lbf]			---	---	235106	

# 210 SERIES

## Vertical Hold Down Clamps | Holding Capacities

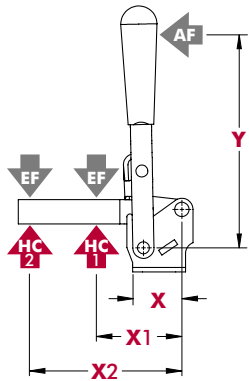

Model	X	X1	X2	Y	±HC1	±HC2	±EF(X1):AF	EF(X2):AF
U/UB/UR		[2.38] 60,5	[4.88] 124	[6.75] 171,5	[600 lbf] 2670 N	[290 lbf] 1290 N	14:1	7:1
USS	[1.54] 39				[750 lbf] 3340 N	[360 lbf] 1600 N		
S/SR/SB		[3.62] 92,0	[5.25] 133	[4.50] 114,5	[750 lbf] 3340 N	[500 lbf] 2220 N	11:1	9:1
TU		[2.38] 60,5	[4.88] 124		[600 lbf] 2670 N	[290 lbf] 1290 N		5:1

Dimensions shown "mm [inch]" ± HC = Holding Capacity, EF = Exerting Force, AF = Applied Force  
See page MC-TEC-4 for additional information.

## Dimensions | -U/-USS/-S/-UB/-SB/-UR/-SR/-TU

**210-U**  
Flanged Base  
U-Bar

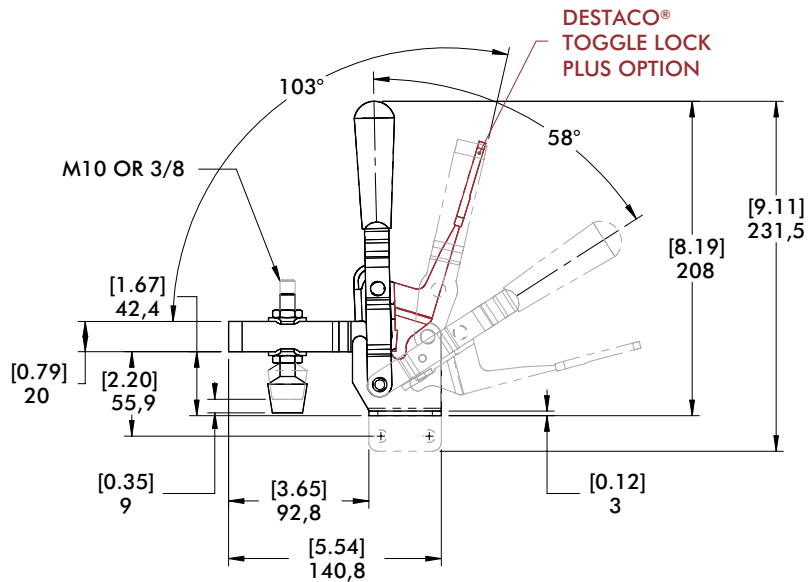
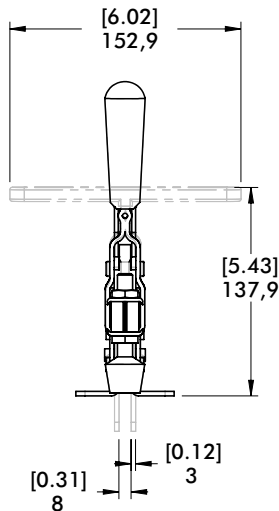
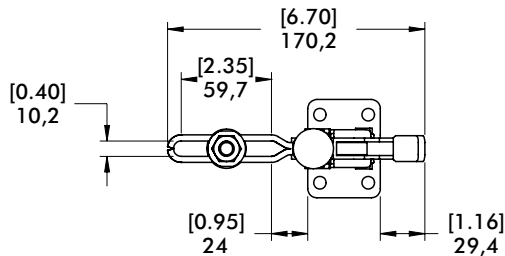

**210-SR**  
Flanged Base  
Solid Bar  
with  
DESTACO®  
Toggle Lock  
Plus™

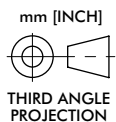
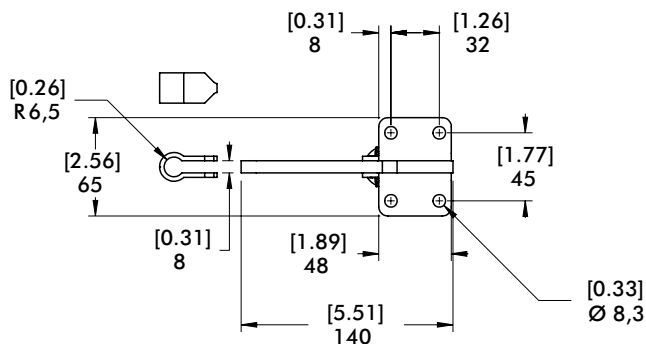

# 247, 267 SERIES

## Vertical Hold Down Clamps | Product Overview

### Features:

- Hardened steel bushings
- Large bar guides for greater lateral stability on Model 247
- Series 247 accommodates M12 or 1/2 spindle accessory
- Series 267 accommodates M16 or 5/8 spindle accessory

### Applications:

- Assembly & test
- Light machining
- Welding

### Also Available:

See page MC-ACC-1 for accessories  
 847-U Pneumatic Toggle Clamp  
 (See page MC-PTC-13)  
 847-S Pneumatic Toggle Clamp  
 (See page MC-PTC-13)

**247-U**  
Flanged Base  
U-Bar



**247-S**  
Flanged Base  
Solid Bar



**267-U**  
Flanged Base  
U-Bar



**267-S①**  
Flanged Base  
Solid Bar



Note:  
Clamps shown with included accessories.

## Technical Information

Model	Max. Holding Capacity	Clamp Bar Opening (+10°)	Handle Opening (+10°)	Weight	Accessories (Supplied)		
					Bolt Retainer	Spindle Assembly	Flanged Washers
247-U	4400 N [1000 lbf]	120°	67°	1,07 kg [2.36 lbs]	---	247208-M	247109
247-S				1,08 kg [2.36 lbs]	247110	---	---
267-U	5340 N [1200 lbf]	140°	72°	2,18 kg [4.80 lbs]	---	267203-M	267102
267-S①				1,98 kg [4.36 lbs]	110122	---	---

① This item is available upon request

## Holding Capacities

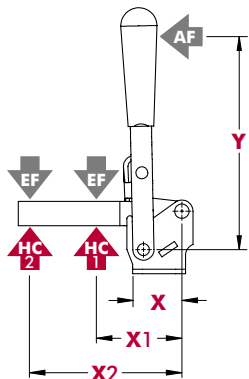

Model	X	X1	X2	Y	±HC1	±HC2	±EF(X1):AF	±EF(X2):AF
247-U	[1.69]	[3.00] 76,2	[6.13] 155,7	[6.71]	[1000 lbf] 4450 N	[480 lbf] 2140 N	12:1	6:1
247-S	43	[4.56] 115,8	[7.00] 177,8	170,5	4450 N	[650 lbf] 2900 N	10:1	5:1
267-U	[2.50]	[4.00] 101,6	[8.00] 203,2	[9.25]	[1200 lbf] 5340 N	[600 lbf] 2670 N	18:1	8:1
267-S①	63,5	[6.00] 152,4	[8.75] 222,3	235	5340 N	[820 lbf] 3650 N	12:1	

Dimensions shown "mm [inch]" ±HC = Holding Capacity, EF = Exerting Force, AF = Applied Force  
 See page MC-TEC-4 for additional information. ① This item is available upon request



# 247, 267 SERIES

## Vertical Hold Down Clamps | Dimensions | -U/-S/-UB

**247-U**  
Flanged Base  
U-Bar

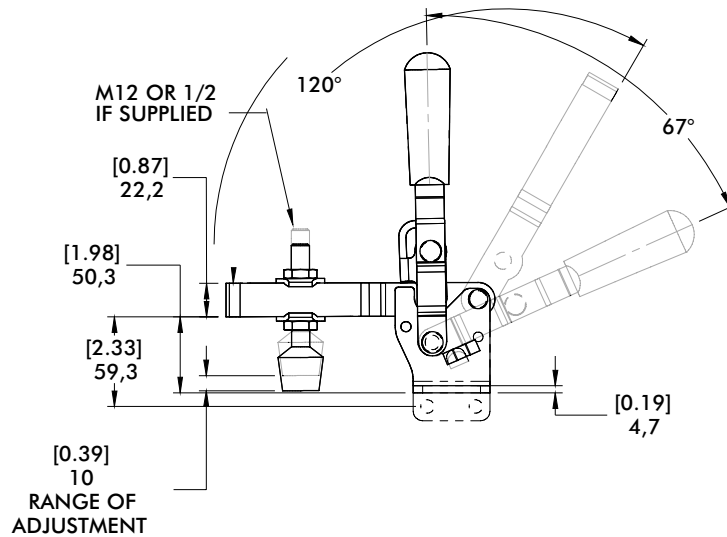
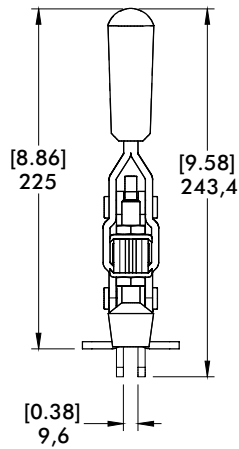
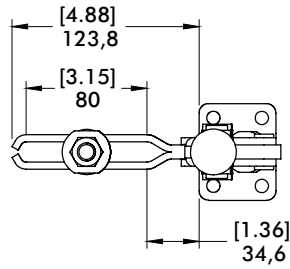

**247-S**  
Flanged Base  
Solid Bar

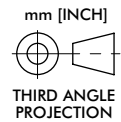
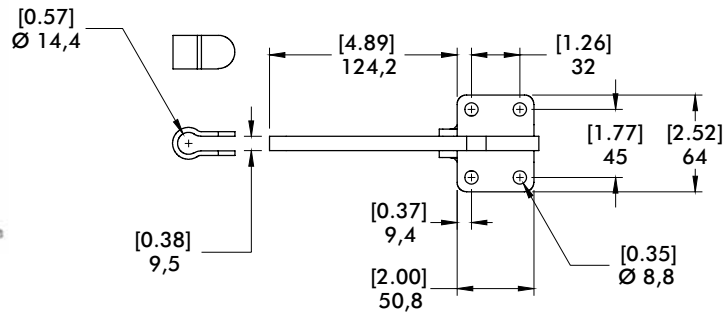

# 267 SERIES

## Vertical Hold Down Clamps | Dimensions

**267-U**  
Flanged Base  
U-Bar

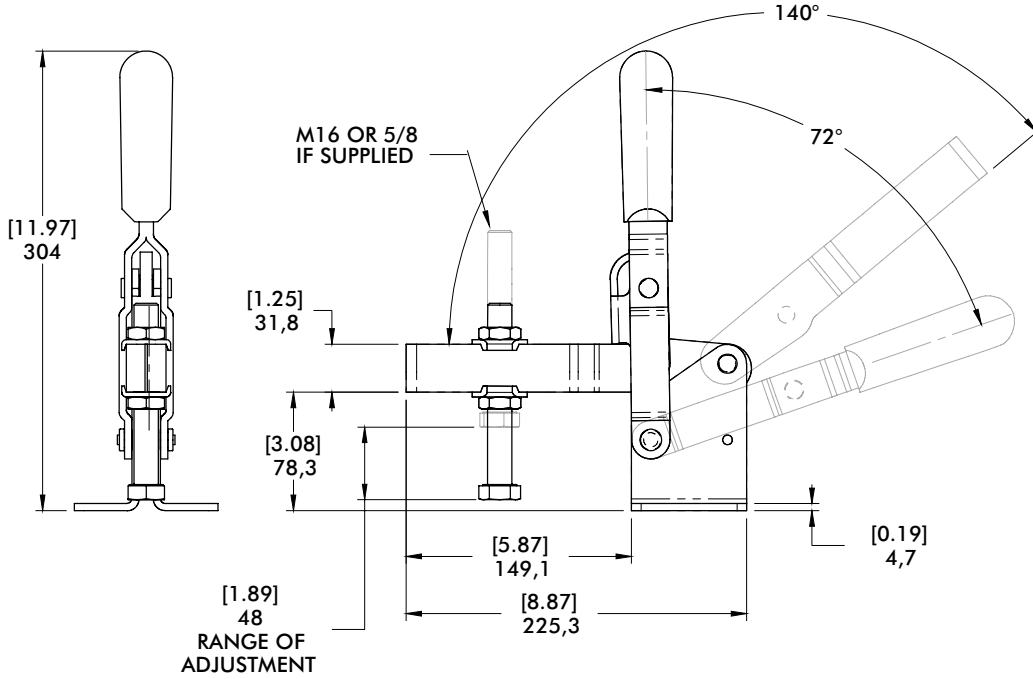
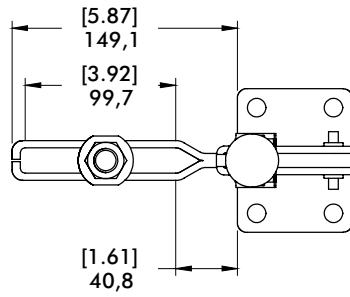

**267-S**  
Flanged Base  
Solid Bar

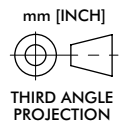
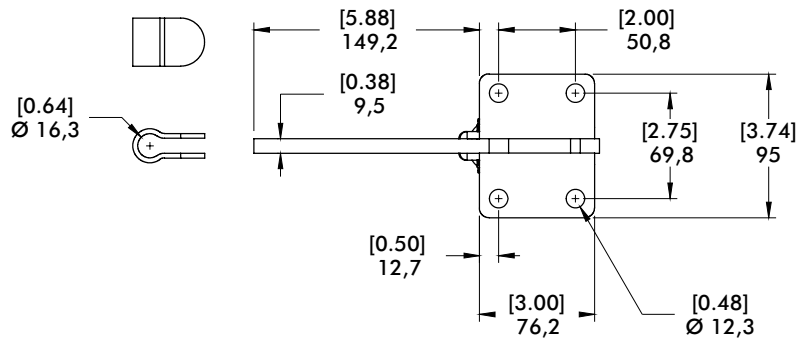

# VERTICAL HOLD DOWN CLAMPS

## Application Examples

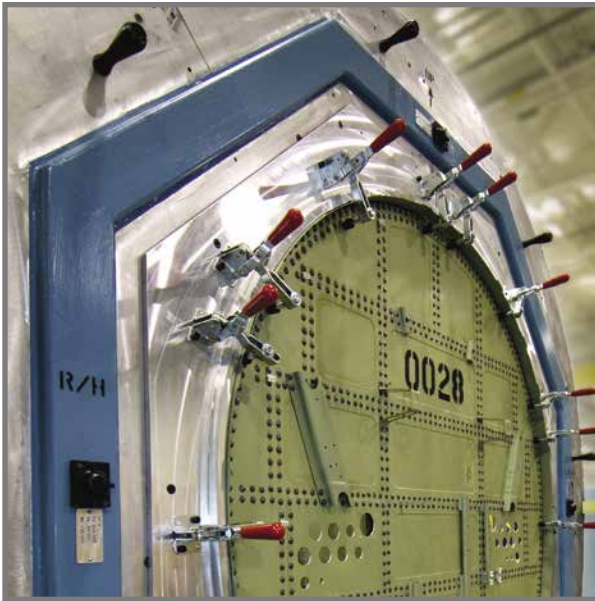

**Model 210-U**  
used in an airframe  
assembly fixture

**Model 210-U**  
shown being used  
in a checking fixture  
application.

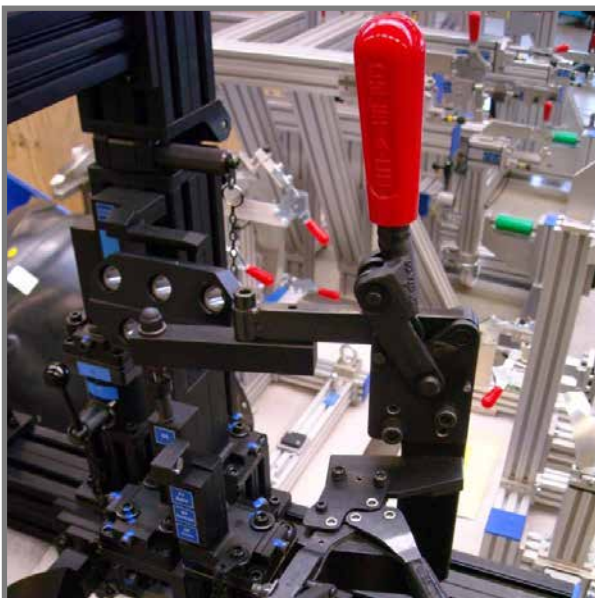

**Model 533-LB**  
and **227-UB** shown  
with black finish in  
a fixture for used for  
optical inspection.

# 5905, 5910, 5915 SERIES

## Heavy-Duty Vertical Hold Down Clamps | Product Overview

### Features:

- High strength forged clamping arm for heavy-duty service
- Hardened steel pivot pins and bushings provide long life
- Black oxide finish

### Applications:

- Welding fixtures
- Assembly fixtures



5905/5910/5915  
Flanged Base



5905-B/5910-B/5915-B  
Solid Base



## Technical Information

Model	Max. Holding Capacity	Clamp Bar Opening (+10°)	Handle Opening (+10°)	Weight
5905	[750 lbf] 3340N	135°	70°	[1.08 lbs] 0,49 kg
5905-B				[0.82 lbs] 0,37 kg
5910	[1600 lbf] 7120N	132°	71°	[2.84 lbs] 1,29 kg
5910-B				[2.24 lbs] 1,02 kg
5915	[2750 lbf] 12230N	147°	74°	[6.16 lbs] 2,79 kg
5915-B				[5.11 lbs] 2,32 kg



Removable handle stop can be repositioned to limit opening angle to 90°

## Holding Forces

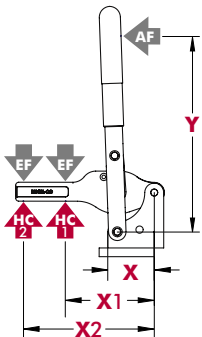

Model	X	X1	X2	Y	±HC1	±HC2	±EF(X1):AF	±EF(X2):AF
5905	[1.25] 31.9	[2.44] 62	[3.46] 88	[5.31] 135	[750 lbf] 3340 N	[525 lbf] 2335 N	10:1	8:1
5910	[1.87] 47.6	[3.34] 85	[5.12] 130	[6.88] 175	[1600 lbf] 7120 N	[1025 lbf] 4550 N	12:1	5:1
5915	[2.50] 63.5	[4.49] 114	[6.89] 175	[9.05] 230	[2750 lbf] 12230 N	[1790 lbf] 7960 N	10:1	7:1

Dimensions shown "mm [inch]" ± HC = Holding Capacity, EF = Exerting Force, AF = Applied Force  
See page MC-TEC-4 for additional information.

# 5905, 5910, 5915 SERIES

## Heavy-Duty Vertical Hold Down Clamps | Dimensions

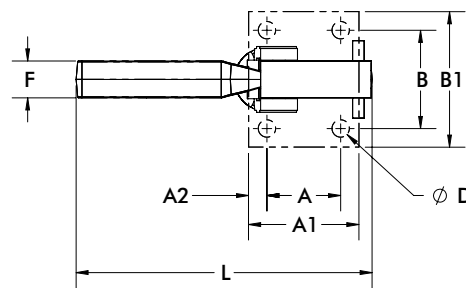
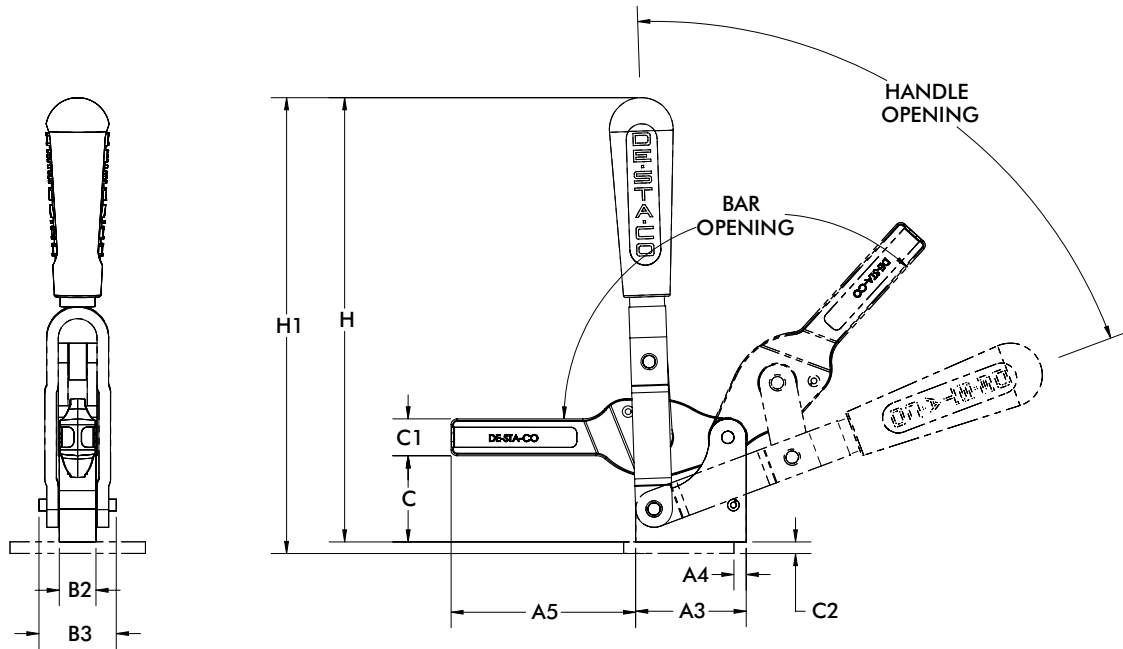

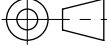
mm [INCH]  
  
 THIRD ANGLE PROJECTION

Model	A	A1	A2	A3	A4	A5	B	B1	B2	B3	C	C1	C2	D	F	H	H1	L
5905	[1.00] 25,4	[1.50] 38,1	[0.25] 6,4	[1.51] 38,4	[0.25] 6,4	[2.49] 63,2	[1.50] 38,1	[2.13] 54,1	[0.59] 15,0	[1.02] 25,9	[1.27] 32,3	[0.51] 12,9	[0.24] 6,1	[0.29] 7,3	[0.56] 14,2	[6.51] 165,4	[6.75] 171,4	[4.02] 102.10
5910	[1.50] 38,1	[2.24] 56,9	[0.37] 9,4	[2.25] 57,2	[0.25] 6,4	[3.76] 95,5	[2.00] 50,8	[2.76] 70,1	[0.75] 19,1	[1.57] 39,9	[1.75] 44,5	[0.75] 19,1	[0.24] 6,1	[0.41] 10,5	[0.75] 19,1	[9.04] 229,5	[9.27] 235,5	[6.02] 152.88
5915	[2.00] 50,8	[2.95] 74,9	[0.48] 12,2	[2.99] 75,9	[0.38] 9,7	[5.00] 127,0	[2.75] 69,9	[3.88] 98,6	[0.98] 24,9	[1.97] 50,0	[2.37] 60,2	[1.00] 25,4	[0.35] 8,9	[0.55] 14,0	[1.00] 25,4	[10.89] 276,7	[11.25] 285,7	[7.50] 190.50

Model	A3	A5	B2	B3
5905-B	[1.51] 38,4	[2.49] 63,2	[0.59] 15,0	[1.02] 25,9
5910-B	[2.25] 57,2	[3.76] 95,5	[0.75] 19,1	[1.57] 39,9
5915-B	[2.99] 76	[4.92] 125	[0.98] 25	[1.97] 50

# 5105, 5110 SERIES

## Heavy-Duty Vertical Hold Down Clamps | Product Overview

### Features:

- High strength forged clamping arm for heavy-duty service
- Hardened steel pivot pins and bushings provide long life
- Black oxide finish
- Large clearance under the clamping bar
- DESTACO® Toggle Lock Plus™ versions available†

### Applications:

- Welding fixtures
- Assembly fixtures



Covered under one or more U.S./International Patents

5105/5110  
Flanged Base



5105-B/5110-B  
Solid Base



5105-R/5110-R  
Flanged Base  
DESTACO®  
Toggle Lock  
Plus™



5105-BRⓈ/5110-BRⓈ  
Solid Base  
DESTACO®  
Toggle Lock  
Plus™



## Technical Information

Model	Max. Holding Capacity	Clamp Bar Opening (+10°)	Handle Opening (+10°)	Weight
5105	[700 lbf] 3100N	89°	159°	[1.12 lbs] 0,51 kg
5105-B				[1.06 lbs] 0,48 kg
5105-R				[1.10 lbs] 0,50 kg
5105-BRⓈ				[1.17 lbs] 0,53 kg
5110	[1150 lbf] 5100N	74°	138°	[2.98 lbs] 1,35 kg
5110-B				[2.95 lbs] 1,34 kg
5110-R				[3.00 lbs] 1,36 kg
5110-BRⓈ				[3.02 lbs] 1,37 kg

Ⓢ This item is available upon request.

† Toggle Lock Plus™ locks the handle in the closed position only.

## Holding Forces

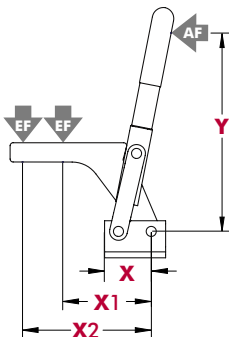

Model	X	X1	X2	Y	±HC1	±HC2	±EF(X1):AF	±EF(X2):AF
5105	[1.24] 31.5	[2.28] 58	[3.38] 86	[5.31] 135	[700 lbf] 3100 N	[475 lbf] 2100 N	14:1	10:1
5110	[1.85] 47	[3.23] 82	[5.24] 133	[6.69] 170	[1150 lbf] 5100 N	[700 lbf] 3100 N	15:1	10:1

Dimensions shown "mm [inch]" ± HC = Holding Capacity, EF = Exerting Force, AF = Applied Force  
See page MC-TEC-4 for additional information.

# 5105, 5110 SERIES

## Heavy-Duty Vertical Hold Down Clamps | Dimensions

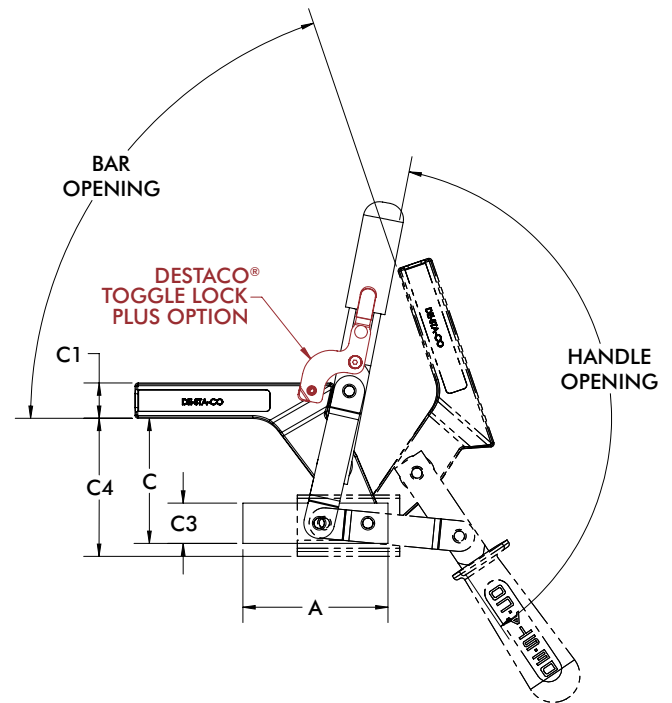
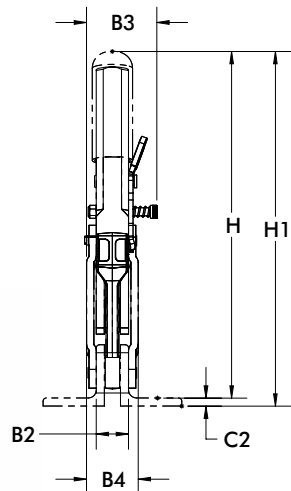

mm [INCH]  
THIRD ANGLE PROJECTION

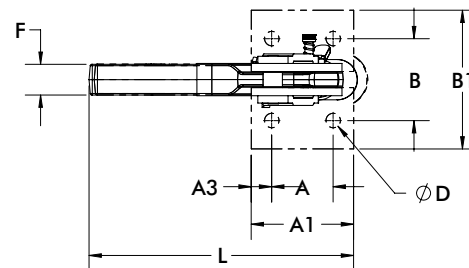

Model	A	A1	A2	B	B1	B2	B3	B4	C1	C2	C4	D	F	H1	L
5105	[1.00]	[1.62]	[0.31]	[1.46]	[2.24]	[0.59]	--	[0.98]	[0.51]	[0.16]	[2.54]	[0.26]	[0.56]	[6.54]	[4.13]
5105-R	25,4	41,2	7,9	37	57	15	[1.48] 37,5	25	13,0	4,0	64,6	6,6	14,3	166,1	104,9
5110	[1.50]	[2.50]	[0.50]	[2.00]	[2.76]	[0.79]	--	[1.26]	[0.87]	[0.20]	[3.37]	[0.35]	[0.75]	[8.70]	[6.33]
5110-R	38,1	63,5	12,7	50,8	70	20	[1.67] 42,5	32	22,0	5,0	85,6	9,0	19,1	221,1	160,9

Model	A3	B2	B3	B4	C	C1	C3	F	H
5105-B	[2.50]	[0.59]	--	[0.98]	[2.14]	[0.51]	[0.59]	[0.56]	[6.14]
5105-BR ⓘ	63,5	15	[1.48] 37,5	25	54,3	13,0	15,0	14,3	156,0
5110-B	[3.54]	[0.79]	--	[1.26]	[3.05]	[0.87]	[0.98]	[0.75]	[8.39]
5110-BR ⓘ	90	20	[1.67] 42,5	32	77,5	22,0	25,0	19,1	213,0

ⓘ This item is available upon request

# 528 SERIES

## Heavy-Duty Vertical Hold Down Clamps | Product Overview

### Features:

- Hardened steel bushings at pivot points for long life
- Solid bar may be modified to suit application requirements

### Applications:

- Assembly & test
- Light machining
- Welding
- Medium to heavy duty clamping requirements

528  
Flanged Base  
Solid Bar



528-F ⓘ  
Front Mount  
Base Solid Bar



### Technical Information

Model	Max. Holding Capacity	Clamp Bar Opening (+10°)	Handle Opening (+10°)	Weight
528	4450 N [1000 lbf]	180°	177°	[2.50 lbs] 1,13 kg
528-F ⓘ				

ⓘ This item is available upon request

### Holding Capacities | Dimensions

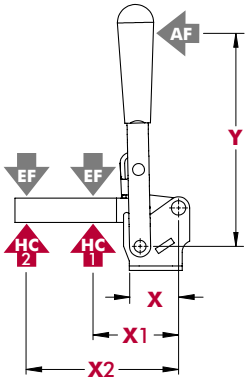

Model	X	X1	X2	Y	±HC1	±HC2	±EF(X1):AF	±EF(X2):AF
528	[1.38]	[3.50]	[6.00]	[5.50]	[1000 lbf]	[580 lbf]	23:1	12:1
528-F	35	89	152	140	4450 N	2580 N		

Dimensions shown "mm [inch]" ± HC = Holding Capacity, EF = Exerting Force, AF = Applied Force  
See page MC-TEC-4 for additional information.

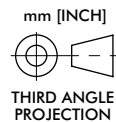
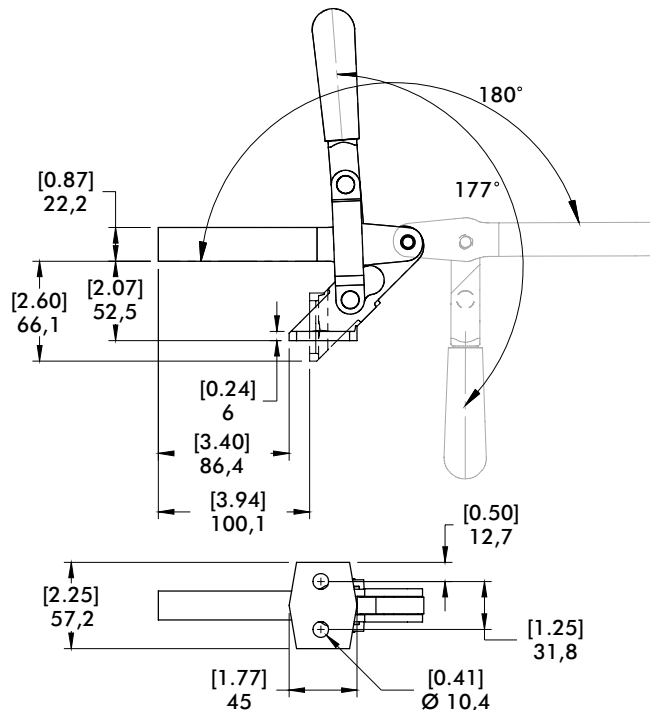
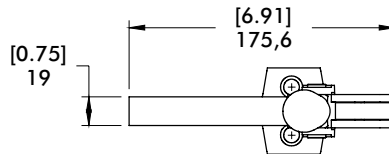
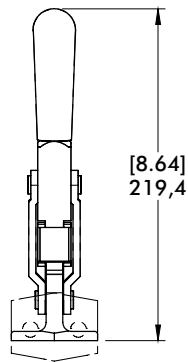



# 548, 578 SERIES

## Heavy-Duty Vertical Hold Down Clamps | Product Overview

### Features:

- Large bar guides for lateral stability
- Hardened steel pins and bushings for long life
- Replaceable pins

### Applications:

- Assembly & test
- Light machining
- Welding
- Heavy duty clamping requirements

548  
Straight Base  
Solid Bar



578  
Straight Base  
Solid Bar



### Technical Information

Model	Max. Holding Capacity	Clamp Bar Opening (+10°)	Handle Opening (+10°)	Weight
548	11100 N [2500 lbf]	199°	129°	2,40 kg [5.30 lbs]
578	17800 N [4000 lbf]			4,14 kg [9.12 lbs]

### Holding Capacities | Dimensions

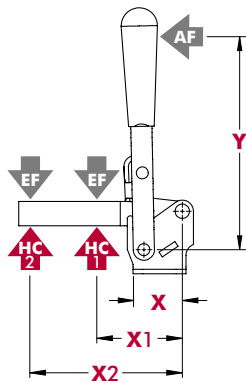

Model	X	X1	X2	Y	±HC1	±HC2	±EF(X1):AF	±EF(X2):AF
548	[2.75] 70	[3.50] 89	[6.00] 152	[7.50] 190	[2500 lbf] 11100 N	[1500 lbf] 6680 N	4.5:1	3.4:1
578	[4.25] 108	[4.50] 114	[7.00] 178	[10.31] 262	[4000 lbf] 17800 N	[2500 lbf] 11100 N	7.6:1	4.2:1

Dimensions shown "mm [inch]" ± HC = Holding Capacity, EF = Exerting Force, AF = Applied Force  
See page MC-TEC-4 for additional information.

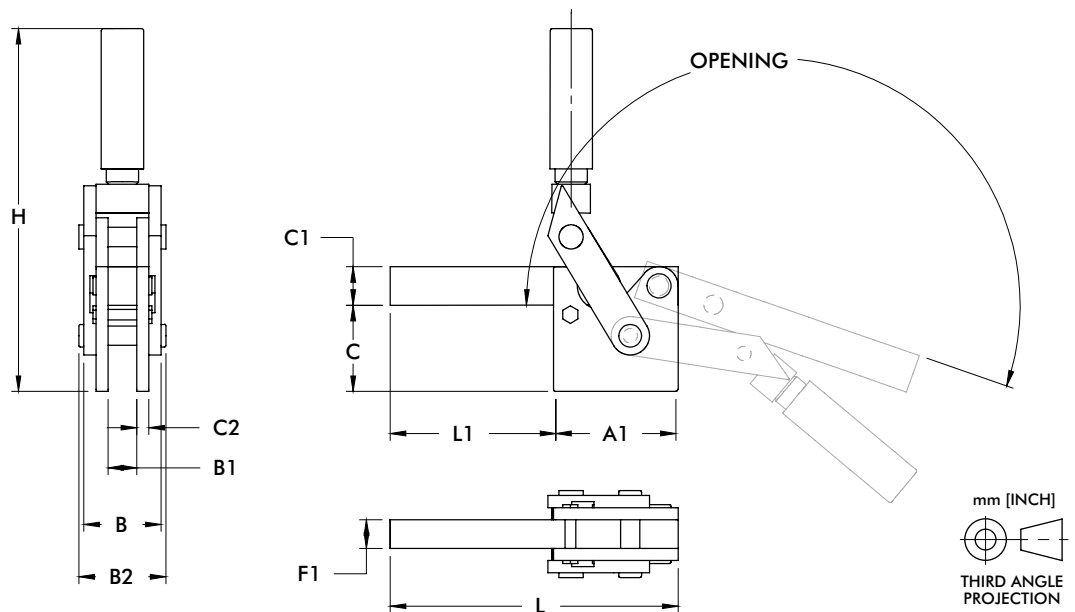

Model	A1	B	B1	B2	C	C1	C2	F1	H	L	L1
548	[3.25] 82,6	[2.01] 51	[0.75] 19,1	[2.26] 57,5	[2.24] 56,9	[1.00] 25,4	[0.31] 7,9	[0.75] 19,1	[9.45] 240	[7.50] 190,5	[4.25] 107,9
578	[4.02] 102,1	[2.38] 60,5	[0.87] 22,1	[2.70] 68,6	[2.79] 70,9	[1.26] 32	[0.37] 9,5	[0.87] 22,1	[11.04] 280,3	[8.62] 219	[4.61] 117,1

# 533, 535 SERIES

## Heavy-Duty Vertical Hold Down Clamps | Product Overview

### Features:

- Hardened steel bushings and pivot pins
- Large bar guides for greater lateral support
- Solid clamping bar may be modified to suit application requirements

### Applications:

- Welding
- Heavy duty clamping applications

### Also Available:

See page MC-ACC-1 for accessories

**533-L**  
Flanged Base  
Solid Bar



**533-LB**  
Straight Base  
Solid Bar



**535-L**  
Flanged Base  
Solid Bar



**535-LB**  
Straight Base  
Solid Bar



## Technical Information

Model	Max. Holding Capacity	Clamp Bar Opening (+10°)	Handle Opening (+10°)	Weight	Accessories (Supplied)
					Bolt Retainer
533-L	7000 N [1575 lbf]	120°	90°	1,00 kg [2.20 lbs]	533108-M
533-LB					
535-L	10000 N [2250 lbf]			1,85 kg [4.087 lbs]	535108-M
535-LB					

## Holding Forces

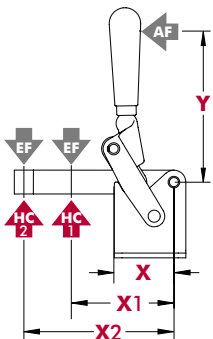

Model	X	X1	X2	Y	±HC1	±HC2	±EF(X1):AF	±EF(X2):AF
533-L	[1.97] 50	[3.25] 82.5	[4.82] 122.5	[5.51] 140	[1575 lbf] 7000 N	[700 lbf] 3100 N	9:1	5:1
535-L	[2.46] 62.5	[4.23] 107.5	[6.20] 157.5	[6.22] 158	[2250 lbf] 10000 N	[1500 lbf] 6600 N	8:1	6:1

Dimensions shown "mm [inch]" ± HC = Holding Capacity, EF = Exerting Force, AF = Applied Force  
See page MC-TEC-4 for additional information.

# 533, 535 SERIES

## Heavy-Duty Vertical Hold Down Clamps | Dimensions

**533-L**  
Flanged Base  
Solid Bar



**535-L**  
Flanged Base  
Solid Bar

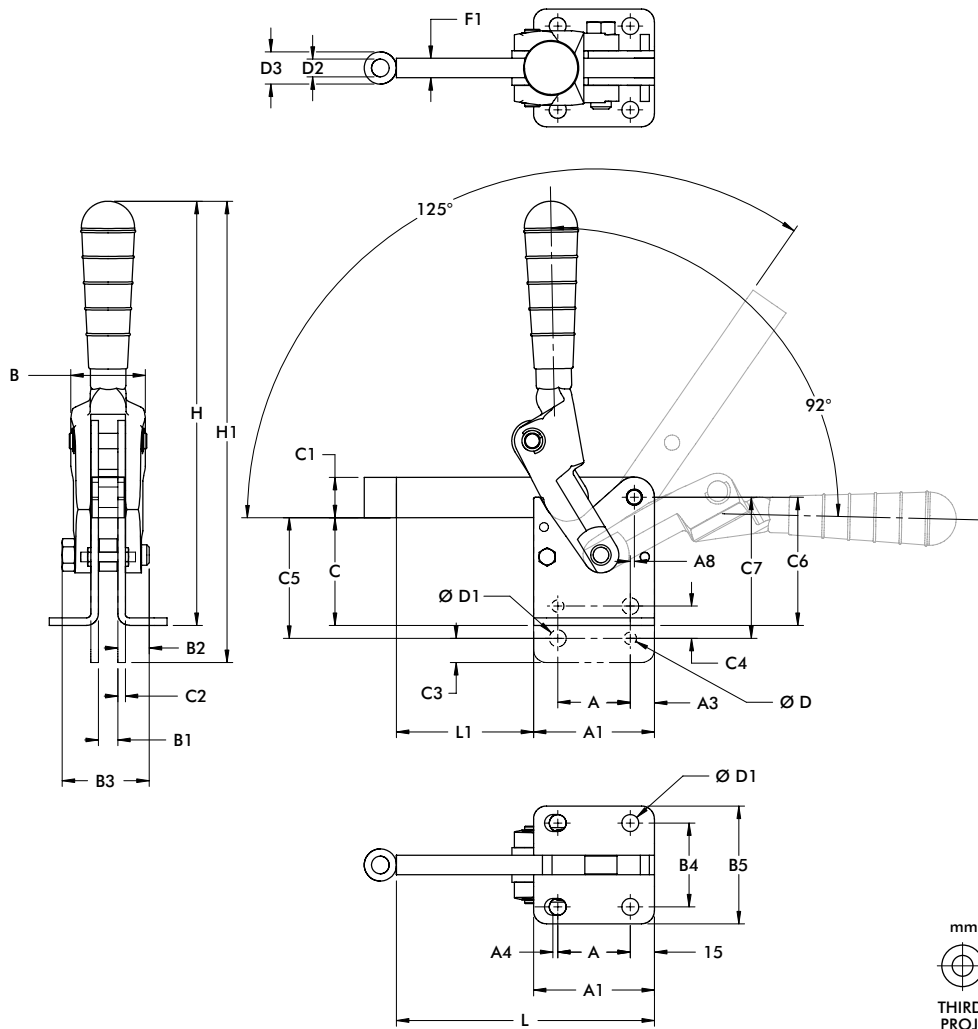

mm [INCH]  
THIRD ANGLE PROJECTION

Model	A	A1	A3	A4	A8	B	B1	B2	B3	B4	B5	C	C1	C2
533-L	[1.18] 30	[2.36] 59,9		[0.08] 2	[0.20] 5,1	[1.52] 38,6	[0.39] 9,9	[0.69] 15,5	[1.75] 44,5	[1.77] 45	[2.44] 62	[1.86] 47,2	[0.79] 20,1	
533-LB			[0.59] 15							--	--	--		[0.19] 4,8
535-L	[1.77] 45	[2.95] 74,9		--	[0.18] 4,6	[1.89] 48	[0.47] 11,9	[0.89] 22,6	[2.13] 54,1	[2.05] 52,1	[2.87] 72,9	[2.63] 66,8	[0.98] 24,9	
535-LB										--	--	--		

Model	C3	C4	C5	C6	C7	D	D1	D2	D3	F1	H	H1	L	L1
533-L	--	--	--	[2.24] 56,9	--	--	[0.33] 8,4	[0.35] 8,9	[0.59] 15	[0.39] 9,9	[8.6] 218,4	--	[4.92] 125	[2.56] 65
533-LB	[0.39] 9,9	[0.59] 15	[1.86] 55,1	--	[2.56] 65	[0.22] 5,6					--	[9.31] 236,5		
535-L	--	--	--	[3.13] 79,5	--	--	[0.41] 10,4	[0.43] 10,9	[0.79] 20,1	[0.47] 11,9	[10.35] 262,9	--	[6.30] 160	[3.35] 85,1
535-LB	[0.59] 15	[0.79] 20,1	[2.95] 74,9	--	[3.44] 87,4	[0.30] 7,6					--	[11.26] 286		

# 91090 SERIES

## Heavy-Duty Vertical Hold Down Clamps | Product Overview

### Features:

- Front flange mount
- Accepts M8 or 5/16" spindle accessory (not supplied)

### Applications:

- Assembly & test
- Checking fixtures
- Light machining
- Woodworking

### Also Available:

See page MC-ACC-1 for accessories

91090  
Front Flanged Base  
Open Bar



## Technical Information | Dimensions

Model	Max. Holding Capacity	Clamp Bar Opening (+10°)	Handle Opening (+10°)	Weight	Recommended Accessories		
					Bolt Retainer	Spindle Assembly	Flanged Washers
91090	1710 N [385 lbf]	100°	60°	0,37 kg [0.81 lbs]	---	507208-M	507107

## Holding Forces

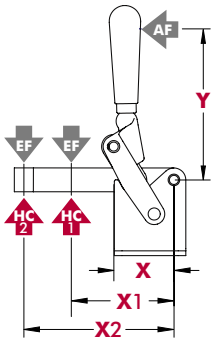

Model	X	X1	X2	Y	±HC1	±HC2	±EF(X1):AF	±EF(X2):AF
91090	[1.39] 35.3	[2.36] 60	[3.74] 95	[4.13] 105	[385 lbf] 1710 N	[240 lbf] 1065 N	8:1	5:1

Dimensions shown "mm [inch]" ± HC = Holding Capacity, EF = Exerting Force, AF = Applied Force  
See page MC-TEC-4 for additional information.

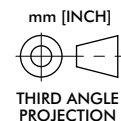
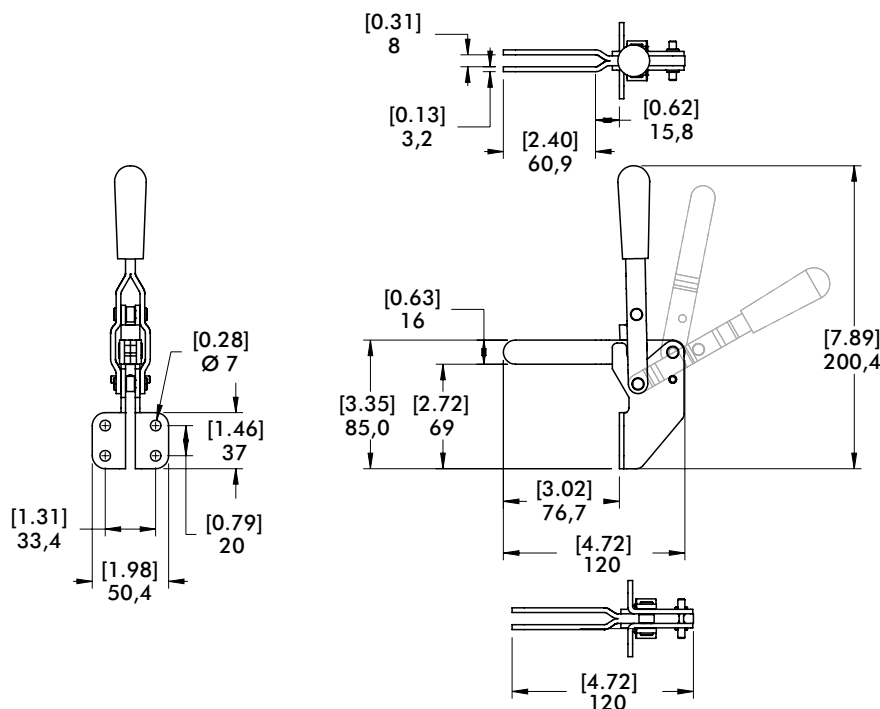



# 317 SERIES

## Vertical Hold Down Clamps | Product Overview

### Features:

- Dual mounting surfaces
- Large bar opening angle
- Accommodates M8 or 5/16" spindle accessories

### Applications:

- Assembly & test
- Checking fixtures
- Light machining
- Woodworking

### Also Available:

See page MC-ACC-1 for accessories  
 817-U Pneumatic Toggle Clamp  
 (See page MC-PTC-19)  
 817-S Pneumatic Toggle Clamp  
 (See page MC-PTC-19)

**317-U**  
U-Bar



**317-S**  
Solid Bar



## Technical Information

Model	Max. Holding Capacity	Clamp Bar Opening (+10°)	Handle Opening (+10°)	Weight	Accessories (Supplied)		
					Bolt Retainer	Spindle Assembly	Flanged Washers
317-U	1670 N [375 lbf]	185°	60°	0,34 kg [0.75 lbs]	---	507208-M	507107
317-S	1780 N [400 lbf]				207105	---	---

## Holding Capacities

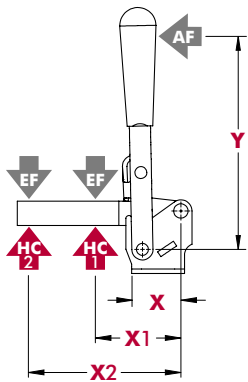

Model	X	X1	X2	Y	±HC1	±HC2	±EF(X1):AF	±EF(X2):AF
317-U	[1.57]	[2.00] 50,8	[3.75] 95,3	[4.00]	[375 lbf] 1670 N	[200 lbf] 900 N	17:1	8:1
317-S	40,0	[2.50] 63,5	[5.00] 127,0	101,6	[400 lbf] 1780 N	[190 lbf] 850 N	13:1	5:1

Dimensions shown "mm [inch]" ± HC = Holding Capacity, EF = Exerting Force, AF = Applied Force  
 See page MC-TEC-4 for additional information.

# 317 SERIES

## Vertical Hold Down Clamps | Dimensions

**317-U**  
U-Bar

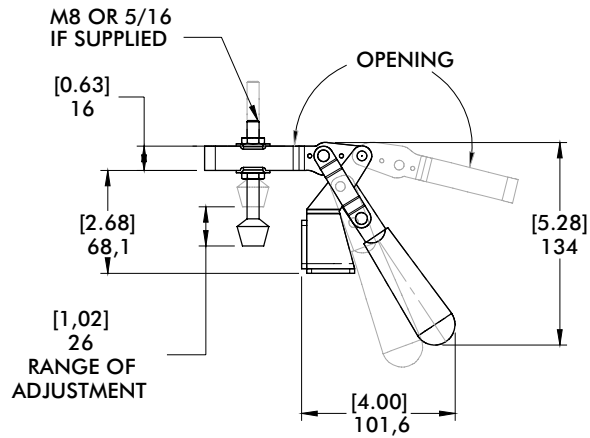
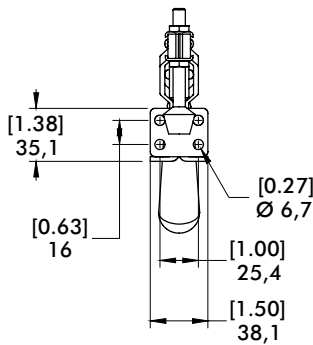
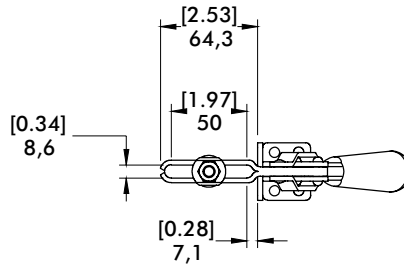

**317-S**  
Solid Bar

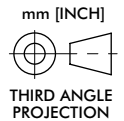
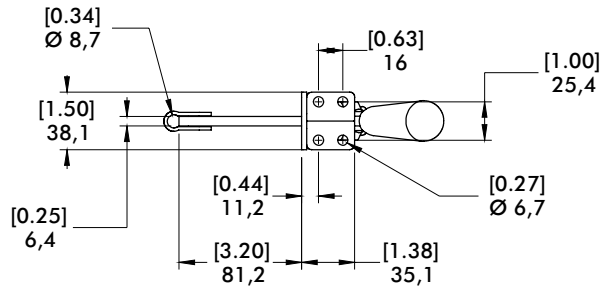

# 527 SERIES

## Vertical Hold Down Clamps | Product Overview

### Features:

- Hardened steel bushings at pivot points
- Solid bar can be modified to suit application requirements
- Thumb lever on link for easy opening

### Applications:

- Assembly & test
- Light machining
- Woodworking

527  
Flanged Base



527-F ⓘ  
Front Mount



## Technical Information

Model	Max. Holding Capacity	Clamp Bar Opening (+10°)	Handle Opening (+10°)	Weight
527	4450 N [1000 lbf]	195°	65°	[2.50 lbs] 1,13 kg
527-F ⓘ				

ⓘ This item is available upon request

## Holding Capacities | Dimensions

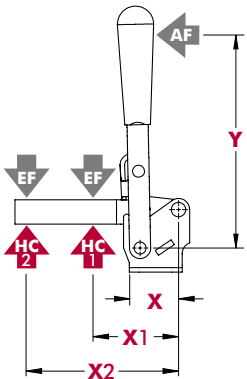

Model	X	X1	X2	Y	±HC1	±HC2	±EF(X1):AF	±EF(X2):AF
527	[3.12] 79,2	[3.50] 89,0	[6.00] 152,4	[4.00] 101,6	[1000 lbf]	[580 lbf]	23:1	12:1
527-F	[2.53] 64,3				4450 N	2580 N		

Dimensions shown "mm [inch]" ± HC = Holding Capacity, EF = Exerting Force, AF = Applied Force  
See page MC-TEC-4 for additional information.

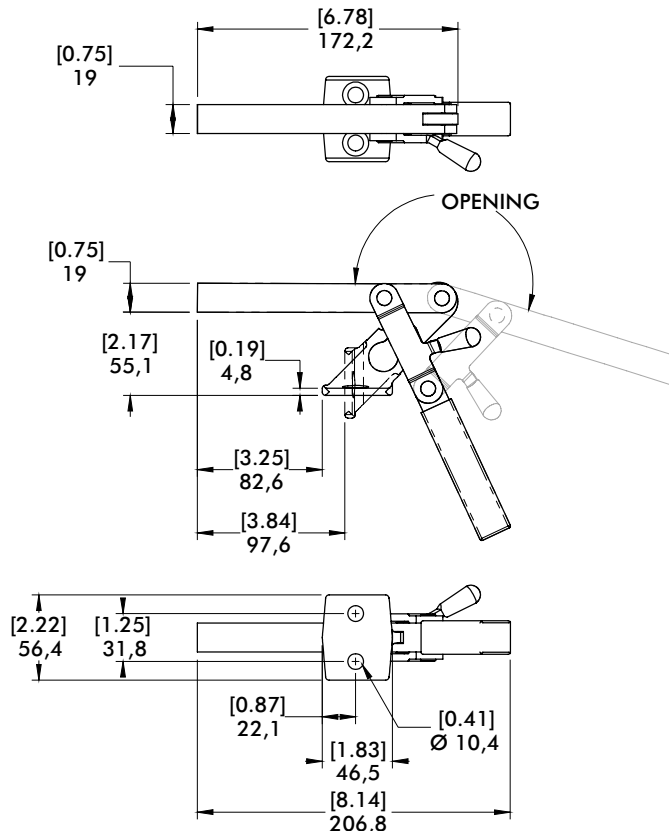
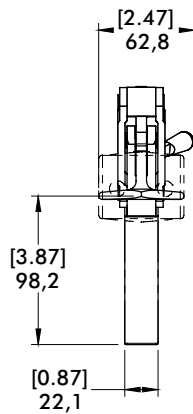

mm [INCH]  
THIRD ANGLE PROJECTION



# 7-101, 7-58, 7-59, 7-60 SERIES

## Heavy Duty Cam Action Series | Product Overview

### Features:

- Cam action accommodates variable workpiece thickness
- Heavy duty construction
- Solid clamp arms may be modified to suit application requirements

### Applications:

- Light machining
- Welding
- Assembly

7-101



7-58  
7-59  
7-60



### Technical Information

Model	Max. Holding Capacity	Clamp Bar Opening (+10°)	Weight
7-101	2110 N [475 lbf]	80°	0,45 kg [1.0 lbs]
7-58	2670 N [600 lbf]	95°	0,91 kg [2.0 lbs]
7-59	4450 N [1000 lbf]	95°	1,36 kg [3.0 lbs]
7-60	7120 N [1600 lbf]	80°	2,27 kg [5.0 lbs]

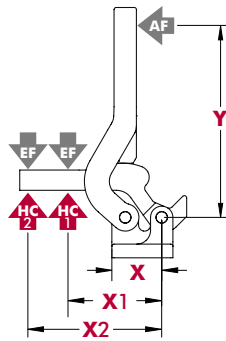

### Holding Forces | Dimensions

Model	X	X1	X2	Y	±HC1	±HC2	±EF(X1):AF	±EF(X2):AF
7-58	[1.38] 35.1	[2.36] 60	[3.54] 90	[5.31] 135	[600 lbf] 2670 N	[400 lbf] 1780 N	5:1	3:1
7-59	[1.69] 42.8	[3.46] 88	[4.72] 120	[6.69] 170	[1000 lbf] 4450 N	[725 lbf] 3225 N	4:1	3:1
7-60	[2.00] 50.8	[4.53] 115	[5.90] 150	[7.48] 190	[1600 lbf] 7120 N	[1225 lbf] 5450 N	4:1	3:1
7-101	[1.00] 25.4	[1.97] 50	[3.74] 95	[3.46] 88	[475 lbf] 2110 N	[250 lbf] 1110 N	1.50:1	1.25:1

Dimensions shown "mm [inch]" ± HC = Holding Capacity, EF = Exerting Force, AF = Applied Force  
See page MC-TEC-4 for additional information.

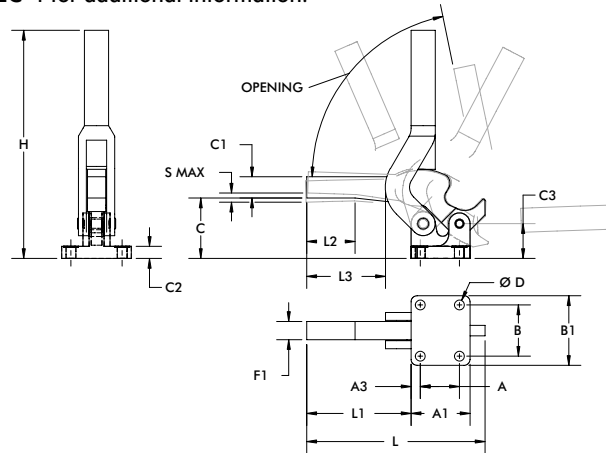

mm [INCH]

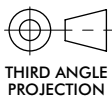

Model	A	A1	A3	B	B1	C	C1	C2	C3	D	F1	H	L	L1	L2	S max.
7-101	[0.75] 19,1	[1.25] 31,8	[0.25] 6,1	[1.25] 31,8	[1.75] 44,5	[1.44] 36,6	[0.50] 12,7	[0.31] 7,9	[1.00] 25,4	[0.22] 5,6	[0.50] 12,7	[5.00] 127	[4.62] 117,3	[3.12] 79,1	-	[0.13] 3,3
7-58	[1.00] 25,4	[1.69] 42,9	[0.34] 8,6	[1.62] 41,2	[2.25] 57,2	[1.87] 47,5	[0.56] 14,2	[0.38] 9,7	[1.12] 28,5	[0.28] 7,1	[0.50] 12,7	[6.93] 176	[4.62] 117,35	[2.55] 64,8	-	[0.13] 3,3
7-59	[1.38] 35,1	[2.06] 52,3	[0.39] 9,9	[1.88] 47,8	[2.50] 63,5	[2.19] 55,6	[0.63] 16	[0.44] 11,2	[1.25] 31,8	[0.34] 8,6	[0.63] 16	[8.50] 215,9	[6.00] 152,4	[3.45] 87,6	[1.24] 31,5	[0.19] 4,8
7-60	[1.62] 41,2	[2.44] 62	[0.44] 11,2	[2.12] 53,9	[2.88] 73,2	[2.50] 63,5	[0.88] 22,4	[0.50] 12,7	[1.44] 36,6	[0.41] 10,4	[0.75] 19,1	[9.44] 239,8	[7.38] 187,5	[4.32] 109,7	[1.97] 50	[0.25] 6,4

# 229 SERIES

## Vertical Hold Down Clamps | Product Overview

### Features:

- Cam action clamp holds workpieces of varying height
- Total clamping range of 8mm [0.31in.]
- Accommodates M12 or 1/2" accessories

### Applications:

- Assembly & test
- Light machining
- Welding

### Also Available:

See page MC-ACC-1 for accessories

229  
Flanged Base  
Open Bar



## Technical Information

Model	Max. Holding Capacity	Clamp Bar Opening (+10°)	Handle Opening (+10°)	Weight	Accessories (Supplied)	
					Spindle Assembly	Flanged Washers
229	4450 N [1000 lbf]	115°	180°	1,17 kg [2.59 lbs]	229203	247109

## Holding Capacities

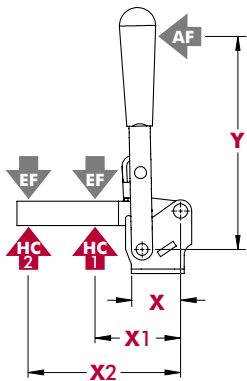

Model	X	X1	X2	Y	±HC1	±HC2	±EF(X1):AF	±EF(X2):AF
229	[1.53] 38,9	[3.00] 76,2	[6.12] 155,4	[7.06] 179,3	[1000 lbf] 4450 N	[500 lbf] 2230 N	7:1	3:1

Dimensions shown "mm [inch]" ± HC = Holding Capacity, EF = Exerting Force, AF = Applied Force  
See page MC-TEC-4 for additional information.

# 229 SERIES

## Vertical Hold Down Clamps | Dimensions

229  
Flanged Base  
Open Bar

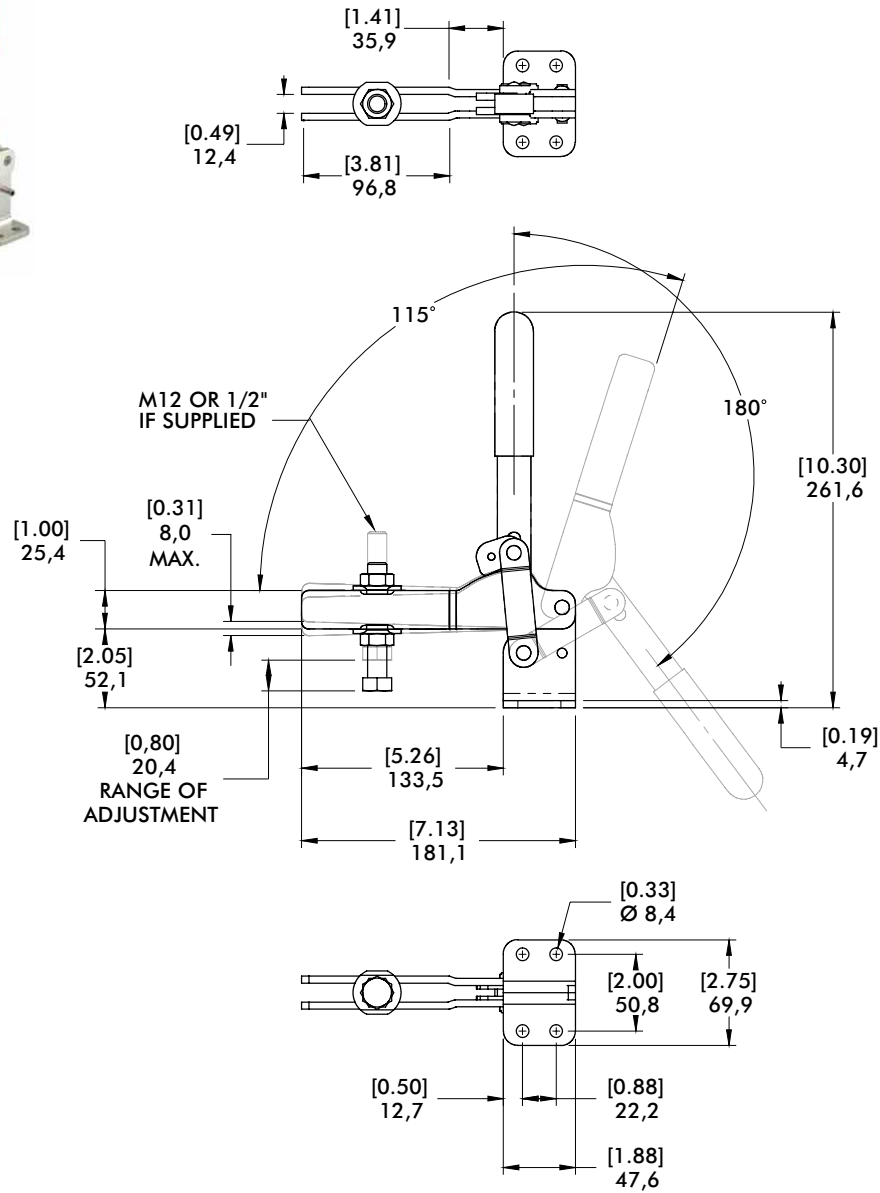

# 500 SERIES

## Weldable Vertical Hold Down Clamps | Product Overview

### Features:

- Hardened pivot pins and bushings
- Weldable clamping bar
- LSC version with locking spring clip for securing the handle in the open position
- Modular design allows you to set up the clamp to meet application requirements

### Applications:

- Welding
- Assembly
- Heavy duty, production clamping applications

### Also Available:

See page MC-VHD-44 for accessories

**503-MB**  
Swivel Base



**503-MLB**  
Long Base



**503-MBLSC** ⓘ  
Swivel Base  
with Locking  
Spring Clip



**503-MLBLS** ⓘ  
Long Base  
with Locking  
Spring Clip



**505-MB**  
Swivel Base



**505-MLB**  
Long Base



**505-MBLSC** ⓘ  
Swivel Base  
with Locking  
Spring Clip



**505-MLBLS** ⓘ  
Long Base  
with Locking  
Spring Clip



**506-MB**  
Swivel Base



**506-MLB** ⓘ  
Long Base



**506-MBLSC** ⓘ  
Swivel Base  
with Locking  
Spring Clip



**506-MLBLS** ⓘ  
Long Base  
with Locking  
Spring Clip



Model 505-MLB in a robotic welding fixture

ⓘ This item is available upon request

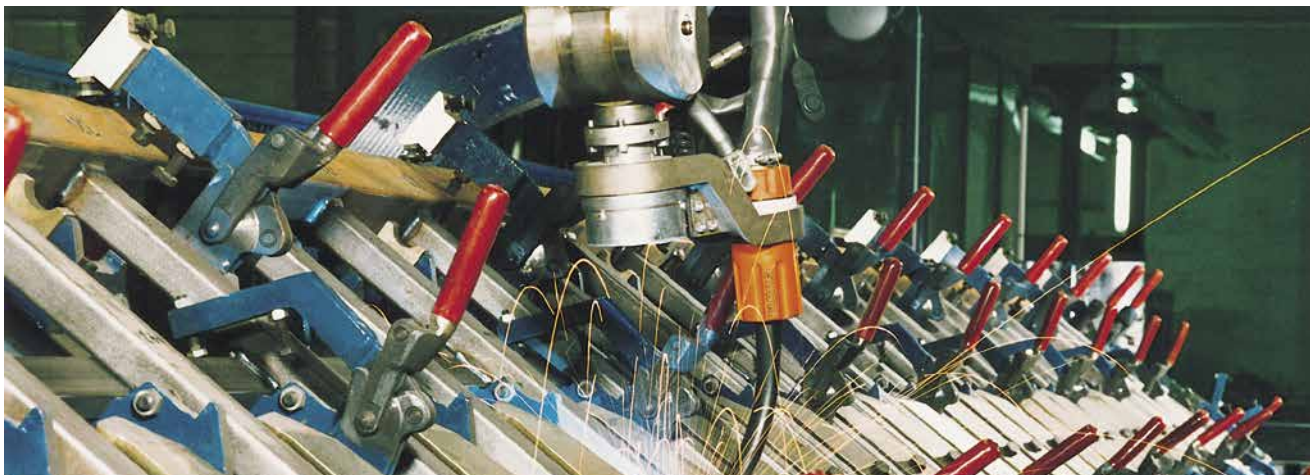

Model	Max. Holding Capacity	Clamp Bar Opening (+10°)	Weight
503-MB	7000 N [1575 lbf]	200°	0,70 kg [1.54 lbs]
503-MLB			0,80 kg [1.76 lbs]
503-MBLSC ⓘ			0,90 kg [1.98 lbs]
505-MB	11000 N [2475 lbf]	200°	1,40 kg [3.09 lbs]
505-MLB			1,50 kg [3.31 lbs]
505-MBLSC ⓘ			1,60 kg [3.53 lbs]
506-MB	22500 N [5060 lbf]	200°	2,60 kg [5.73 lbs]
506-MLB ⓘ			2,80 kg [6.17 lbs]
506-MBLSC ⓘ			2,80 kg [6.17 lbs]
506-MLBLSC ⓘ			3,00 kg [6.61 lbs]

**Note:**

The clamping bars are made from forged alloy steel and must be heated to 200°C(400°F) prior to welding. We recommend welding the handles, clamp arms, and mounting bases when disassembled. Welding of non pre-heated parts may only be done with the addition of welding fillers.

ⓘ This item is available upon request

Clamping Position

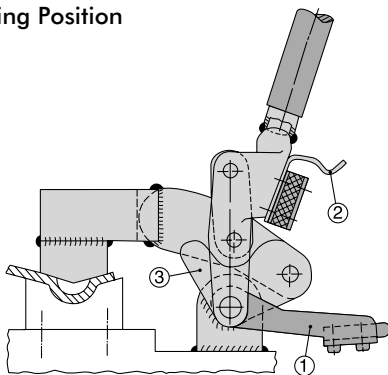

Patented spring latch hold-open device

1. Mount the clamp and place it in the closed position
2. Position the bracket in the leaf spring

Open Position

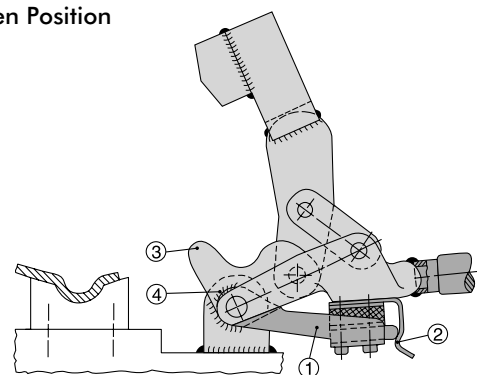

3. Swivel the clamp into the open position
4. In this position, weld the bracket with the bar guide feature at point

# 500 SERIES

Weldable Vertical Hold Down Clamps | Dimensions | -B/-LB/-MB/-MLB/-MBLSC/-MLBLSC

## Swivel Base

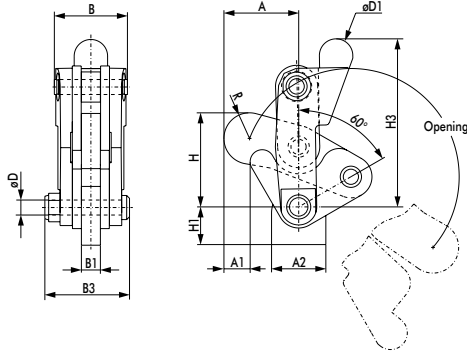

**503-MB**  
Swivel Base

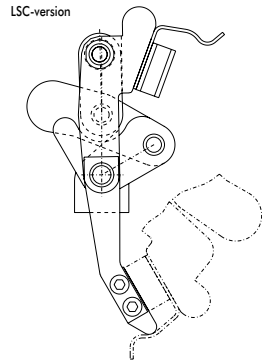

## Long Base

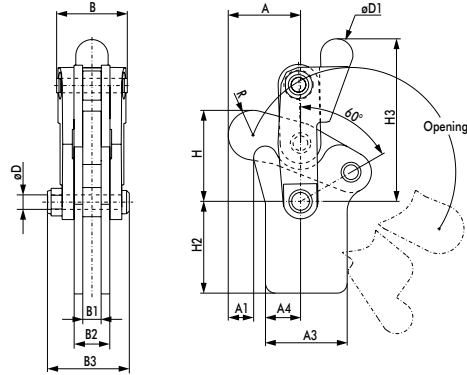

**503-MLB**  
Long Base

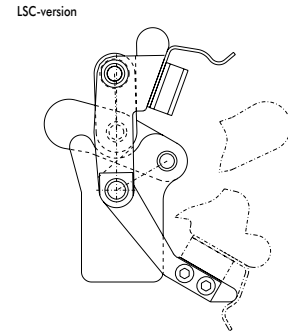

mm [INCH]

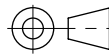

THIRD ANGLE  
PROJECTION

## Swivel Base Dimensions

Model	A	A1	A2	B	B1	B3	ØD	ØD1	H	H1	H3	R
503-MB	[1.54]	[0.50]	[1.12]	[1.52]	[0.39]	[1.82]	[0.31]	[0.69]	[1.96]		[3.51]	[0.53]
503-MBLSC ⓘ	39,2	12,8	28,5	38,5	10	46,2	8	17,5	49,8		89,1	13,5
505-MB	[2.22]	[1.02]	[1.38]	[1.89]	[0.48]	[2.31]	[0.37]	[0.87]	[2.79]	[1.10]	[4.33]	[0.72]
505-MBLSC ⓘ	56,5	25,9	35	48	12,3	58,6	9,5	22,2	70,8	28	110,1	18,3
506-MB	[2.82]	[1.27]	[1.97]	[1.91]	[0.63]	[2.72]	[0.47]	[0.94]	[3.45]	[1.29]	[5.30]	[0.84]
506-MBLSC ⓘ	71,7	32,3	50	48,4	16	69	12	24	87,7	32,8	134,6	21,4

## Long Base Dimensions

Model	A	A1	A3	A4	B	B1	B2	B3	ØD	ØD1	H	H2	H3	R
503-MLB	[1.54]		[1.75]	[0.75]	[1.52]	[0.39]	[0.79]	[1.82]	[0.31]	[0.69]	[1.96]	[1.97]	[3.51]	[0.53]
503-MLBLSC ⓘ	39,2		44,5	19	38,5	10	20	46,2	8	17,5	49,8	50	89,1	13,5
505-MLB	[2.22]	[1.02]	[2.09]	[1.08]	[1.89]	[0.48]	[0.88]	[2.31]	[0.37]	[0.87]	[2.79]	[2.50]	[4.33]	[0.72]
505-MLBLSC ⓘ	56,5	25,9	53	27,5	48	12,3	22,3	58,6	9,5	22,2	70,8	63,5	110,1	18,3
506-MLB	[2.82]	[1.27]	[2.58]	[1.45]	[1.91]	[0.63]	[1.10]	[2.72]	[0.47]	[0.94]	[3.45]	[3.00]	[5.30]	[0.84]
506-MLBLSC ⓘ	71,7	32,3	65,5	36,9	48,4	16	28	69	12	24	87,7	76,2	134,6	21,4

### Features:

- Used with 500 Series Vertical Clamps
- Allows you to customize the clamp to suit application requirements

### Applications:

- Welding
- Assembly
- Heavy duty, production clamping applications

### Also Available:

See page MC-VHD-41 for clamp linkage

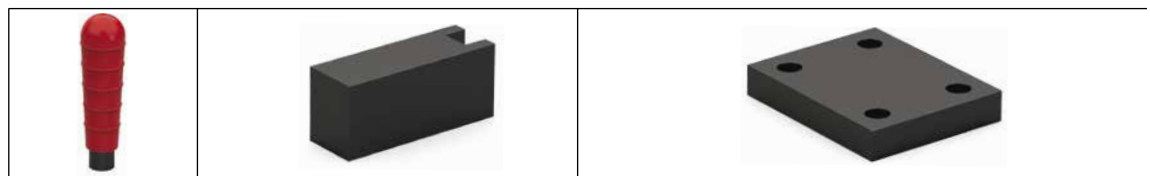
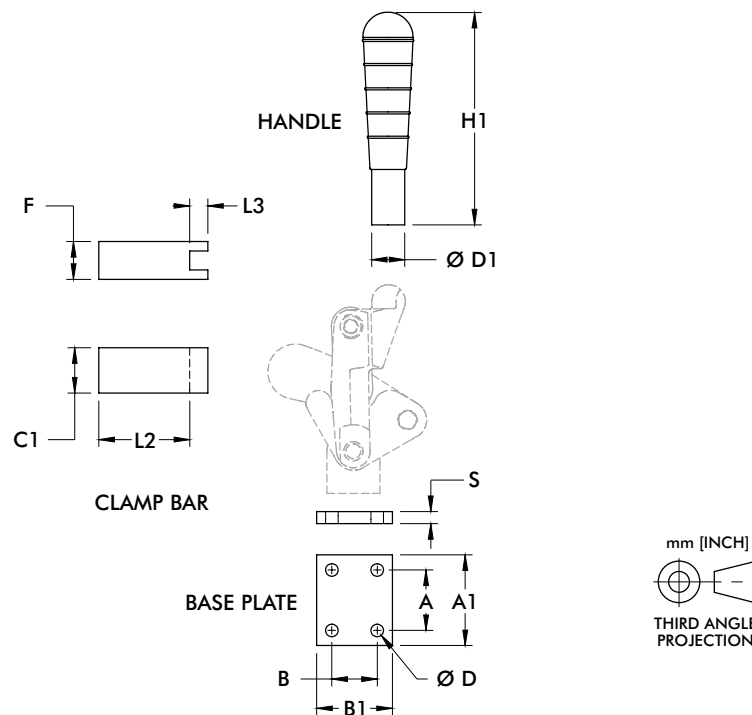

Use with	Part No.	Handle		Clamping Bar				Base Plate					
		ØD1	H1	C1	F	L2	L3	A	A1	B	B1	ØD	S
503	503503-L	Ø18	129.5	-	-	-	-	-	-	-	-	-	-
	503501	-	-	25	20	50	8	-	-	-	-	-	-
	503502	-	-	-	-	-	-	25	40	35	50	6.3	8
505	505503-L	Ø22	159	-	-	-	-	-	-	-	-	-	-
	505501	-	-	30	25	60	12	-	-	-	-	-	-
	505502	-	-	-	-	-	-	40	60	30	50	8.1	8
506	506503-L	Ø28	188	-	-	-	-	-	-	-	-	-	-
	506501	-	-	35	30	75	15	-	-	-	-	-	-
	506502	-	-	-	-	-	-	50	70	45	65	8.1	8

ⓘ This item is available upon request Note: Dimensions shown in millimeters.

# 2013 SERIES

## Horizontal Hold Down Clamps | Product Overview

### Features:

- Increased handle clearance reduces pinch points
- Common mounting hole pattern to Model 213
- Fixed handle pivot provides smooth action
- Nearly 2 times the holding capacity Model 213
- BLK models feature a black, non-reflective finish

### Applications:

- Checking fixtures
- Assembly & test
- Light machining
- Woodworking
- Closures

### Also Available:

See page MC-ACC-1 for accessories  
Accommodates M5 or #10 spindle accessory

Covered under one or more U.S./International Patents

**2013-U**  
Flanged Base  
U-Bar



**2013-U-LS-BLK** ⓘ  
Blackout Series  
Flanged Base  
U-Bar



**2013-UR**  
Flanged Base  
U-Bar  
DESTACO®  
Toggle Lock  
Plus™



ⓘ This item is available upon request

## Technical Information

Model	Max. Holding Capacity	Clamp Bar Opening (+10°)	Handle Opening (+10°)	Weight	Accessories (Supplied)	
					Spindle Assembly	Flanged Washers
2013-U	1310 N [295 lbf]	71°	58°	0,17 kg [0.37 lb]	2013208-M	102111
2013-U-LS-BLK ⓘ					--	102111-BLK
2013-UR					2013208-M	102111

ⓘ This item is available upon request

## Holding Capacities

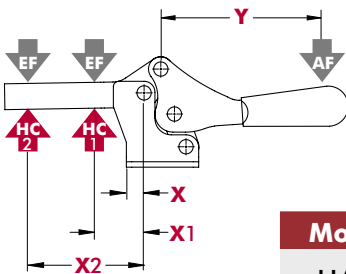

Model	X	X1	X2	Y	‡HC1	‡HC2	‡EF(X1):AF	‡EF(X2):AF
U/UR	[0.63] 16	[0.95] 24	[1.95] 49,5	[2.34] 59,5	[295 lbf] 1310 N	[175 lbf] 780 N	6:1	4:1

Dimensions shown "mm [inch]" ‡ HC = Holding Capacity, EF = Exerting Force, AF = Applied Force  
See page MC-TEC-4 for additional information.



**2013-U**  
Flanged Base  
U-Bar

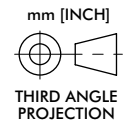
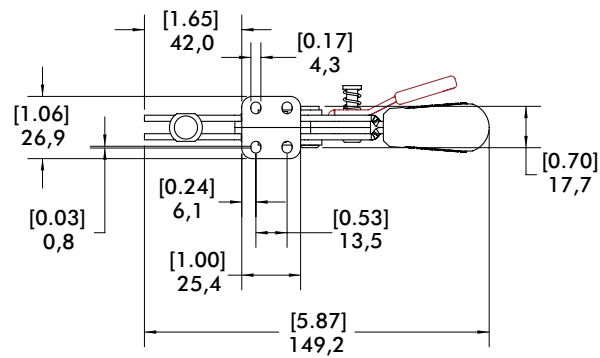
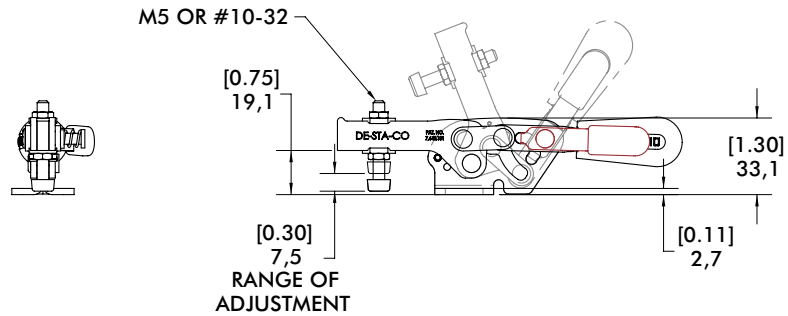
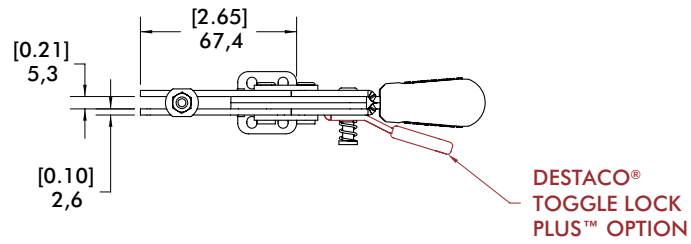

# 2017 SERIES

## Horizontal Hold Down Clamps | Product Overview

### Features:

- Increased handle clearance reduces pinch points
- Common mounting hole pattern to Model 217
- Fixed handle pivot provides smooth action
- Over 2½ times the holding capacity Model 217
- BLK models feature a black, non-reflective finish

### Applications:

- Checking fixtures
- Assembly & test
- Light machining
- Woodworking
- Closures

### Also Available:

See page MC-ACC-1 for accessories  
Accommodates M6 or ¼" spindle accessory

Covered under one or more U.S./International Patents

**2017-U**  
Flanged Base  
U-Bar



**2017-U-LS-BLK** ⓘ  
Blackout Series  
Flanged Base  
U-Bar



**2017-UR**  
Flanged Base  
U-Bar  
DESTACO®  
Toggle Lock  
Plus™



ⓘ This item is available upon request

## Technical Information

Model	Max. Holding Capacity	Clamp Bar Opening (+10°)	Handle Opening (+10°)	Weight	Accessories (Supplied)	
					Spindle Assembly	Flanged Washers
2017-U	2500 N [560 lbf]	73°	69°	0,44 kg [0.97 lb]	215208-M	215105
2017-U-LS-BLK ⓘ					--	215105-BLK
2017-UR					215208-M	215105

ⓘ This item is available upon request

## Holding Capacities

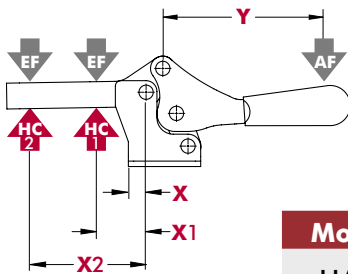

Model	X	X1	X2	Y	‡HC1	‡HC2	‡EF(X1):AF	‡EF(X2):AF
U/UR	[1.08] 27,4	[1.65] 42	[3.15] 80	[2.54] 64,5	[560 lbf] 2500 N	[245 lbf] 1090 N	5:1	2.5:1

Dimensions shown "mm [inch]" ‡ HC = Holding Capacity, EF = Exerting Force, AF = Applied Force  
See page MC-TEC-4 for additional information.

**2017-U**  
Flanged Base  
U-Bar

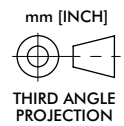
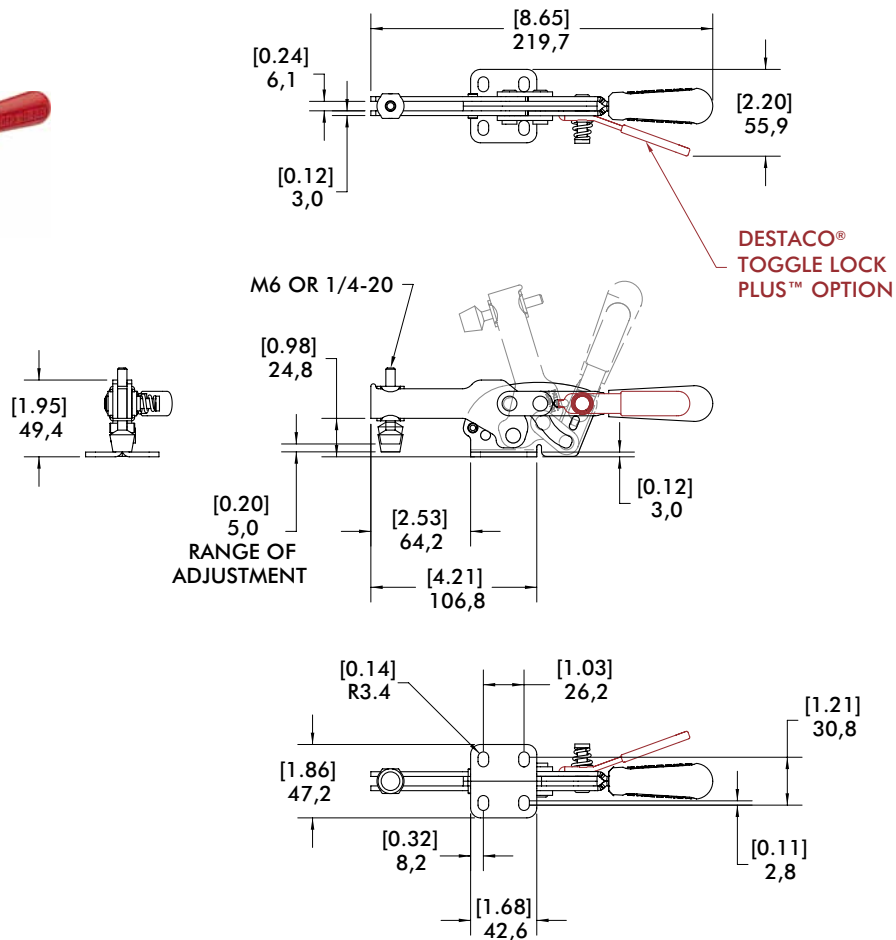

# 2027 SERIES

## Horizontal Hold Down Clamps | Product Overview

### Features:

- Increased handle clearance reduces pinch points
- Common mounting hole pattern to Model 227
- Fixed handle pivot provides smooth action
- Over 1½ times the holding capacity Model 227
- BLK models feature a black, non-reflective finish

### Applications:

- Checking fixtures
- Assembly & test
- Light machining
- Woodworking
- Closures

### Also Available:

See page MC-ACC-1 for accessories  
Accommodates M8 or 5/16" spindle accessory

Covered under one or more U.S./International Patents

**2027-U**  
Flanged Base  
U-Bar



**2027-U-LS-BLK** ⓘ  
Blackout Series  
Flanged Base  
U-Bar



**2027-UR**  
Flanged Base  
U-Bar  
DESTACO®  
Toggle Lock  
Plus™



ⓘ This item is available upon request

## Technical Information

Model	Max. Holding Capacity	Clamp Bar Opening (+10°)	Handle Opening (+10°)	Weight	Accessories (Supplied)	
					Spindle Assembly	Flanged Washers
2027-U	3740 N [840 lbf]	68°	70°	0,61 kg [1.34 lb]	2007208-M	507107
2027-U-LS-BLK ⓘ					--	507107-BLK
2027-UR					2007208-M	507107

ⓘ This item is available upon request

## Holding Capacities

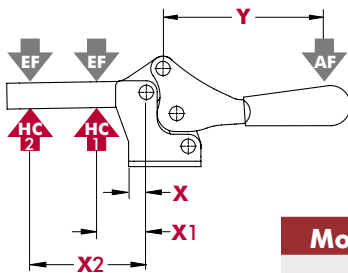

Model	X	X1	X2	Y	±HC1	±HC2	±EF(X1):AF	±EF(X2):AF
U/UR	[1.02] 25,8	[1.75] 44,5	[3.30] 83,8	[2.54] 64,5	[840 lbf] 3740 N	[480 lbf] 2140 N	5:1	3:1

Dimensions shown "mm [inch]" ± HC = Holding Capacity, EF = Exerting Force, AF = Applied Force  
See page MC-TEC-4 for additional information.

**2027-U**  
Flanged Base  
U-Bar

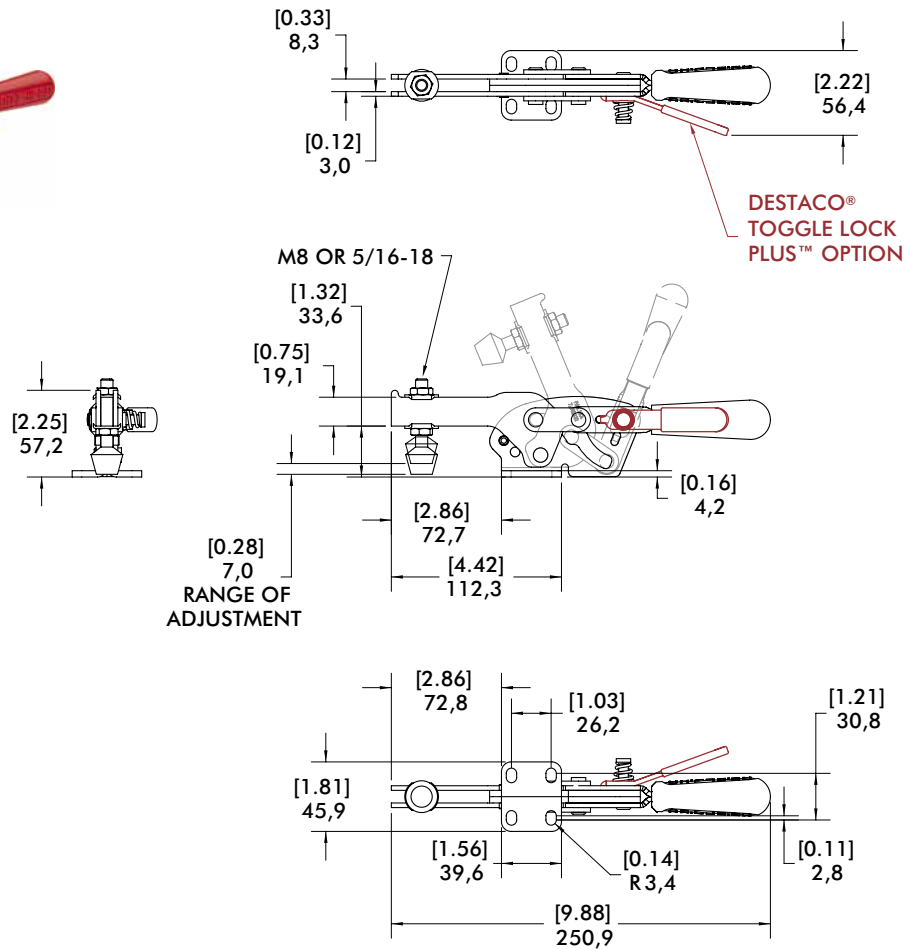

# 213 SERIES

## Horizontal Hold Down Clamps | Product Overview

### Features:

- Low profile
- Large handle clearance in the open position
- Available in stainless steel
- BLK models feature a black, non-reflective finish

### Applications:

- Assembly
- Checking fixtures
- Closures
- Woodworking

### Also Available:

See page MC-ACC-1 for accessories  
Accommodates M5 or #10 spindle accessory

**213-U/USS**  
Flanged Base  
U-Bar



-USS Stainless Steel Model



**213-U-LS-BLK** ⓘ  
Blackout Series  
Flanged Base  
U-Bar



**213-UB**  
Straight Base  
U-Bar



**213-UB-LS-BLK** ⓘ  
Blackout Series  
Straight Base  
U-Bar



**213-U-L** ⓘ  
Flanged Base  
Open Bar



**213-U-L-BLK** ⓘ  
Flanged Base  
Open Bar



**213-UB-L** ⓘ  
Straight Base  
Open Bar



**213-UB-L-BLK** ⓘ  
Blackout Series  
Straight Base  
Open Bar



ⓘ This item is available upon request

## Technical Information

Model	Max. Holding Capacity	Clamp Bar Opening (+10°)	Handle Opening (+10°)	Weight	Accessories (Supplied)	
					Spindle Assembly	Flanged Washers
213-U	670 N [150 lbf]	90°	60°	0,08 kg [0.17 lb]	213208-M	102111
213-U-LS-BLK ⓘ					--	102111-BLK
213-USS					201943-M	102911
213-UB					213208-M	102111
213-UB-LS-BLK ⓘ					--	102111-BLK
213-U-L ⓘ						102111
213-U-L-BLK ⓘ						102111-BLK
213-UB-L ⓘ						102111
213-UB-L-BLK ⓘ					102111-BLK	

ⓘ This item is available upon request

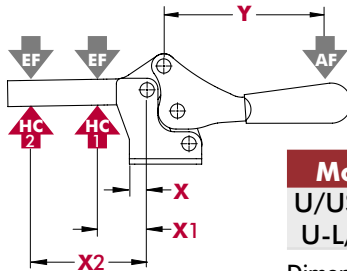

Model	X	X1	X2	Y	±HC1	±HC2	±EF(X1):AF	±EF(X2):AF
U/USS/UB	[0.36]	[0.75]	[1.63]	[1.81]	[150 lbf]	[70 lbf]	7:1	3:1
U-L/UB-L	9,3	19	41,4	46	670 N	310 N		

Dimensions shown "mm [inch]" ± HC = Holding Capacity, EF = Exerting Force, AF = Applied Force  
See page MC-TEC-4 for additional information.

### Dimensions | -U/-USS/-UB

#### 213-U Flanged Base U-Bar

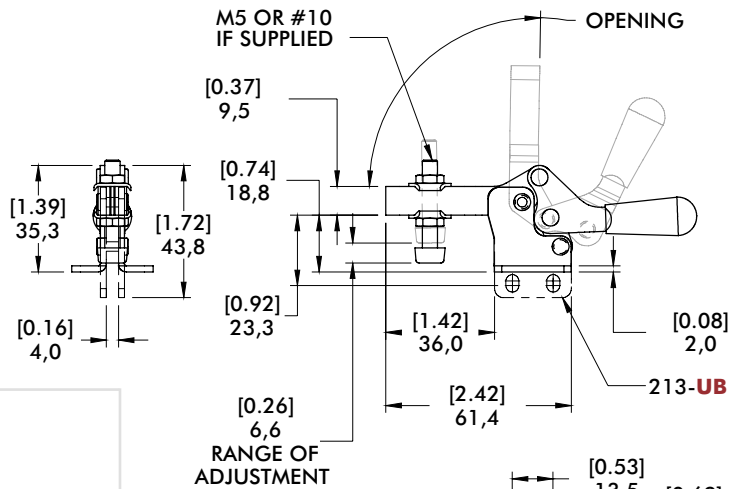
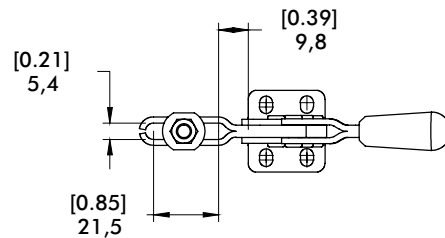

### Series 213 Open Bar Options



#### Flanged Base Model 213-U-L ⓘ

See page MC-ACC-7 for Complete offering of Open bar accessories

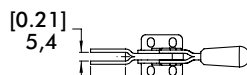

#### Straight Base Model 213-UB-L ⓘ

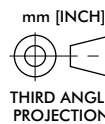
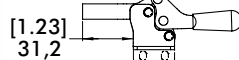

# 217 SERIES

## Horizontal Hold Down Clamps | Product Overview

### Features:

- Low profile
- Large handle clearance in the open position
- Available in stainless steel
- BLK models feature a black, non-reflective finish

### Applications:

- Assembly
- Checking fixtures
- Closures
- Woodworking

### Also Available:

See page MC-ACC-1 for accessories  
Accommodates M6 or 1/4" spindle accessory

**217-U/USS**  
Flanged Base  
U-Bar



-USS Stainless Steel Model



**217-U-LS-BLK** ⓘ  
Blackout Series  
Flanged Base  
U-Bar



**217-UB**  
Straight Base  
U-Bar



**217-UB-LS-BLK** ⓘ  
Blackout Series  
Straight Base  
U-Bar



**217-U-L** ⓘ  
Flanged Base  
Open Bar



**217-U-L-BLK** ⓘ  
Flanged Base  
Open Bar



**217-UB-L** ⓘ  
Straight Base  
Open Bar



**217-UB-L-BLK** ⓘ  
Blackout Series  
Straight Base  
Open Bar



ⓘ This item is available upon request

## Technical Information

Model	Max. Holding Capacity	Clamp Bar Opening (+10°)	Handle Opening (+10°)	Weight	Accessories (Supplied)		
					Spindle Assembly	Flanged Washers	
217-U	900 N [200 lbf]	91°	61°	0,18 kg [0.40 lb]	202208-M	215105	
217-U-LS-BLK ⓘ					--	215105-BLK	
217-USS	1110 N [250 lbf]				202943-M	215105	
217-UB					202208-M	215105	
217-UB-LS-BLK ⓘ						215105-BLK	
217-U-L ⓘ	900 N [200 lbf]					215105	
217-U-L-BLK ⓘ						--	215105-BLK
217-UB-L ⓘ							215105
217-UB-L-BLK ⓘ				215105-BLK			

ⓘ This item is available upon request



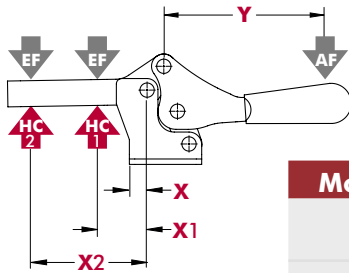

Model	X	X1	X2	Y	±HC1	±HC2	±EF(X1):AF	±EF(X2):AF
U					[200 lbf] 900 N	[80 lbf] 360 N		
USS	[0.53] 13,5	[1.13] 28,6	[2.63] 66,8	[2.93] 74,5	[250 lbf] 1110 N	[100 lbf] 440 N	7:1	3:1
UB/U-L/ UB-L					[200 lbf] 900 N	[80 lbf] 360 N		

Dimensions shown "mm [inch]" ± HC = Holding Capacity, EF = Exerting Force, AF = Applied Force  
See page MC-TEC-4 for additional information.

### Dimensions | -U/-USS/-UB

#### Series 217 Open Bar Options



**Flanged Base**  
Model  
**217-U-L**



**Straight Base**  
Model  
**217-UB-L**

See page MC-ACC-7 for  
Complete offering of  
Open bar accessories

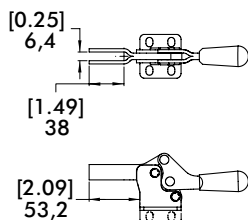

#### 217-U Flanged Base U-Bar

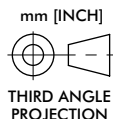
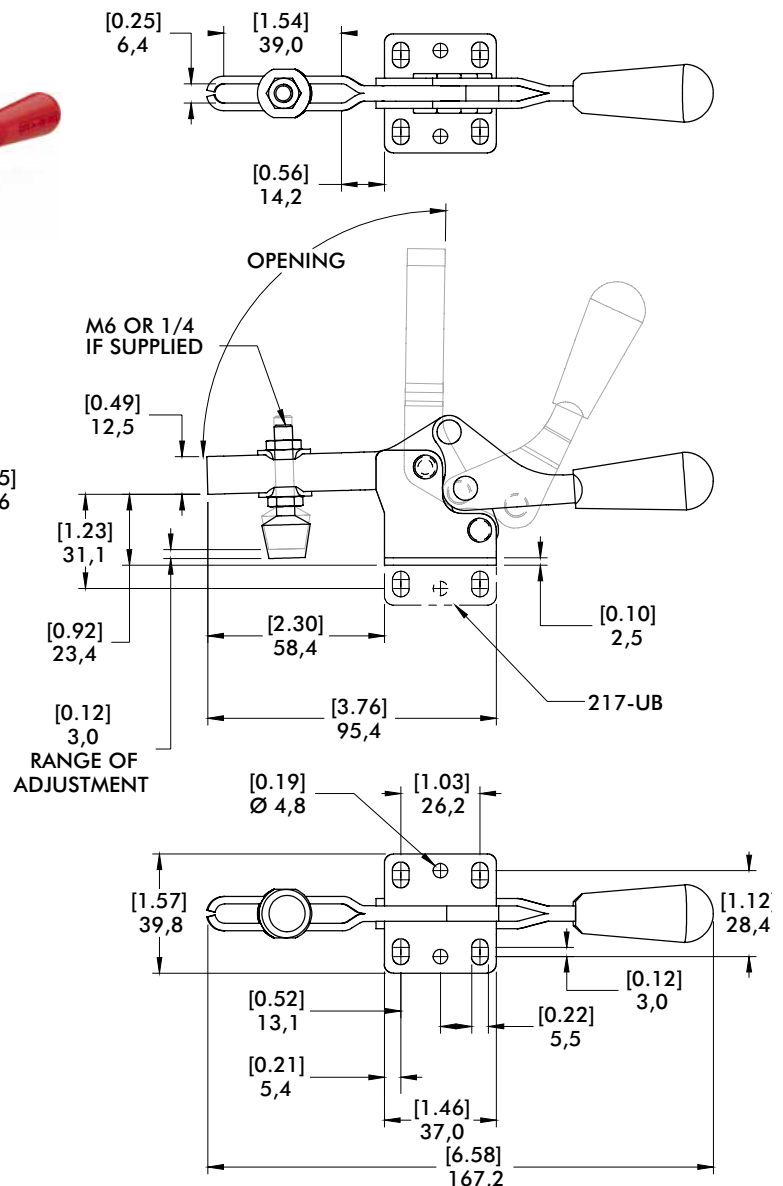
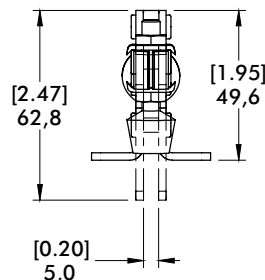

# 227 SERIES

## Horizontal Hold Down Clamps | Product Overview

### Features:

- Low profile
- Large handle clearance in the open position.
- Available in stainless steel
- BLK models feature a black, non-reflective finish

### Applications:

- Assembly
- Checking fixtures
- Closures
- Woodworking

### Also Available:

See page MC-ACC-1 for accessories  
Accommodates M6 or 5/16" spindle accessory

**227-U/USS**  
Flanged Base  
U-Bar



-USS Stainless Steel Model



**227-U-LS-BLK** ⓘ  
Blackout Series  
Flanged Base  
U-Bar



**227-UB**  
Straight Base  
U-Bar



**227-UB-LS-BLK** ⓘ  
Blackout Series  
Straight Base  
U-Bar



**227-U-L** ⓘ  
Flanged Base  
Open Bar



**227-U-L-BLK** ⓘ  
Flanged Base  
Open Bar



**227-UB-L** ⓘ  
Straight Base  
Open Bar



**227-UB-L-BLK** ⓘ  
Blackout Series  
Straight Base  
Open Bar



ⓘ This item is available upon request

## Technical Information

Model	Max. Holding Capacity	Clamp Bar Opening (+10°)	Handle Opening (+10°)	Weight	Accessories (Supplied)	
					Spindle Assembly	Flanged Washers
227-U	2220 N [500 lbf]	91°	56°	0,31 kg [0.68 lb]	225208-M	507107
227-U-LS-BLK ⓘ					--	507107-BLK
227-USS	2670 N [600 lbf]				-207943-M	507907
227-UB	2220 N [500 lbf]				225208-M	507107
227-UB-LS-BLK ⓘ					--	507107-BLK
227-U-L ⓘ					--	507107
227-U-L-BLK ⓘ					--	507107-BLK
227-UB-L ⓘ					--	507107
227-UB-L-BLK ⓘ		--	507107-BLK			

ⓘ This item is available upon request

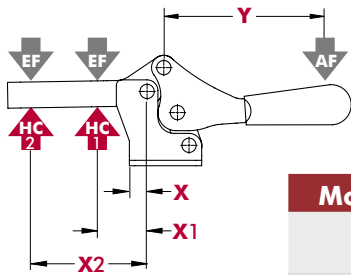

Model	X	X1	X2	Y	±HC1	±HC2	±EF(X1):AF	±EF(X2):AF
U					[500 lbf] 2220 N	[225 lbf] 1000 N		
USS	[0.39] 10,0	[1.25] 31,8	[2.75] 70,0	[3.58] 91,0	[600 lbf] 2670 N	[270 lbf] 1200 N	8:1	3:1
UB/U-L/ UB-L					500 lbf 2220 N	[225 lbf] 1000 N		

Dimensions shown "mm [inch]" ± HC = Holding Capacity, EF = Exerting Force, AF = Applied Force  
See page MC-TEC-4 for additional information.

### Dimensions | -U/-USS/-UB

**227-U**  
Flanged Base  
U-Bar

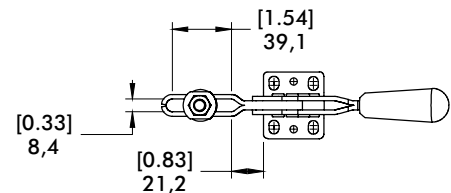

### Series 227 Open Bar Options



**Flanged Base**  
Model  
**227-U-L**

See page MC-ACC-7 for Complete offering of Open bar accessories

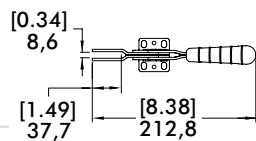

**Straight Base**  
Model  
**227-UB-L**

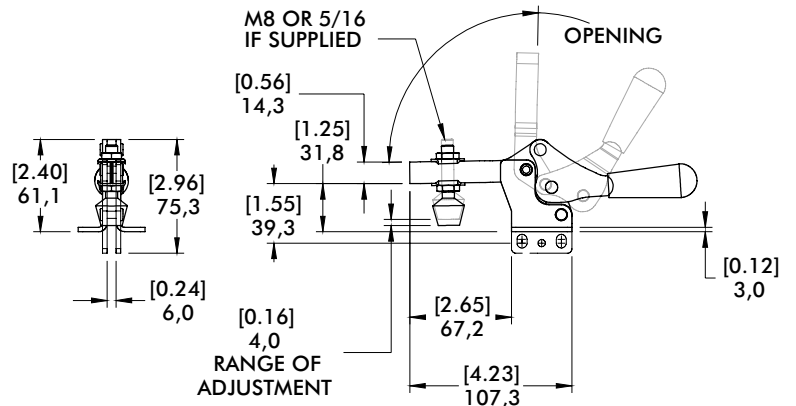
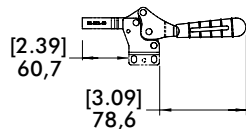

M8 OR 5/16 IF SUPPLIED

OPENING

RANGE OF ADJUSTMENT

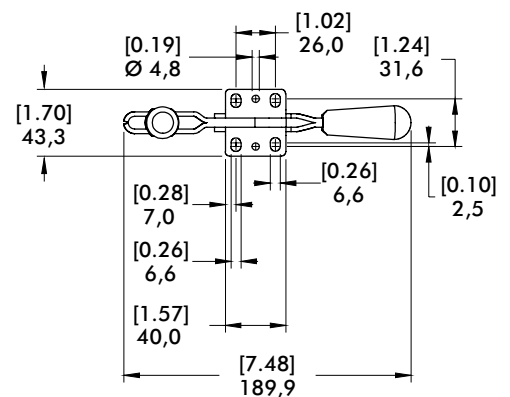
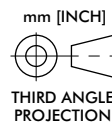

# 237 SERIES

## Horizontal Hold Down Clamps | Product Overview

### Features:

- Low profile
- Large handle clearance in the open position.
- Available in stainless steel

### Applications:

- Assembly
- Checking fixtures
- Welding

### Also Available:

See page MC-ACC-1 for accessories  
Accommodates M10 or 3/8" spindle accessory

### 237-U/USS Flanged Base U-Bar



-USS Stainless Steel Model



## Technical Information

Model	Max. Holding Capacity	Clamp Bar Opening(+10°)	Handle Opening (+10°)	Weight	Accessories (Supplied)	
					Spindle Assembly	Flanged Washers
237-U	3340 N [750 lbf]	93°	59°	0,73 kg [1.60 lb]	240208-M	235106
237-USS ⓘ	3780 N [850 lbf]				237943-M	235906

ⓘ This item is available upon request

## Holding Capacities

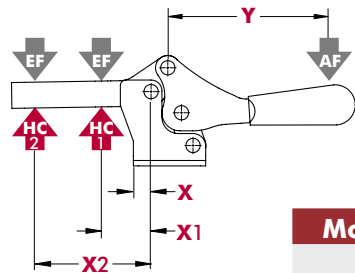

Model	X	X1	X2	Y	±HC1	±HC2	±EF(X1):AF	±EF(X2):AF
U	[0.81]	[1.75]	[4.50]	[5.25]	[750 lbf] 3340 N	[290 lbf] 1290 N	6:1	2:1
USS	20,6	44,5	114,3	133,3	[850 lbf] 3780 N	[330 lbf] 1470 N		

Dimensions shown "mm [inch]" ± HC = Holding Capacity, EF = Exerting Force, AF = Applied Force  
See page MC-TEC-4 for additional information.

**237-U**  
Flanged Base  
U-Bar

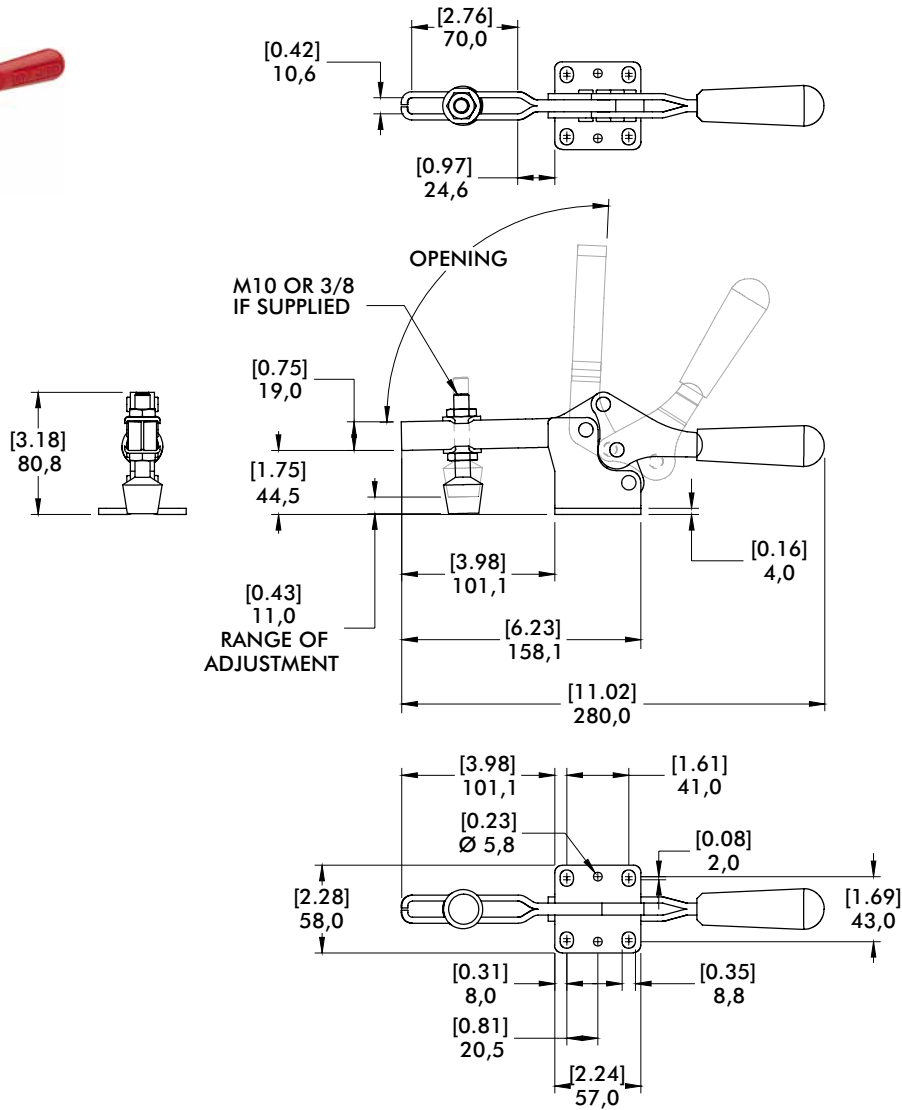

# 245 SERIES

## Horizontal Hold Down Clamps | Product Overview

### Features:

- Low profile
- Large handle clearance in the open position.

### Applications:

- Assembly
- Checking fixtures
- Welding

### Also Available:

See page MC-ACC-1 for accessories  
Accommodates M12 or 1/2" spindle accessory

**245-U**  
Flanged Base  
U-Bar



## Technical Information

Model	Max. Holding Capacity	Clamp Bar Opening (+10°)	Handle Opening (+10°)	Weight	Accessories (Supplied)	
					Spindle Assembly	Flanged Washers
245-U	4450 N [1000 lbf]	105°	74°	1,32 kg [2.90 lb]	247208-M	247109

## Holding Capacities

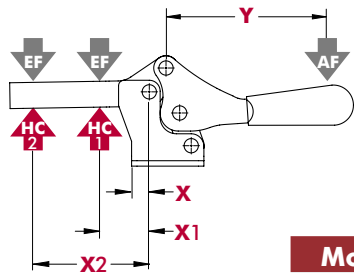

Model	X	X1	X2	Y	±HC1	±HC2	±EF(X1):AF	±EF(X2):AF
U	[0.50] 12,7	[2.00] 50,8	[5.00] 127	[6.09] 154,7	[1000 lbf] 4450 N	[400 lbf] 1780 N	11:1	5:1

Dimensions shown "mm [inch]" ‡ **HC** = Holding Capacity, **EF** = Exerting Force, **AF** = Applied Force  
See page MC-TEC-4 for additional information.

**245-U**  
Flanged Base  
U-Bar

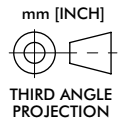
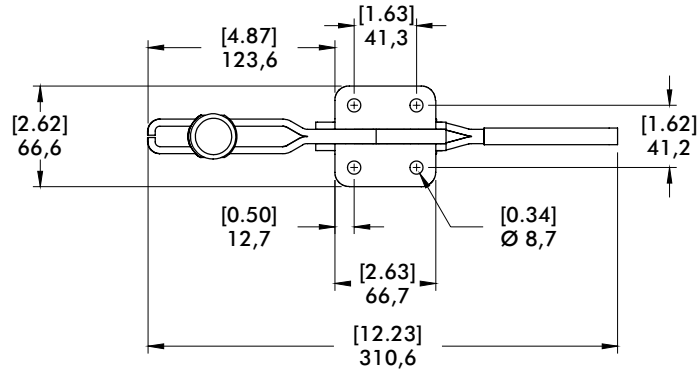
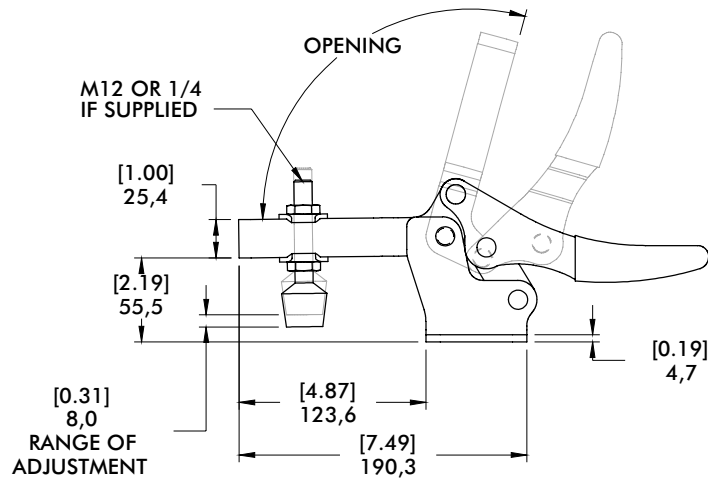
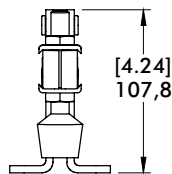
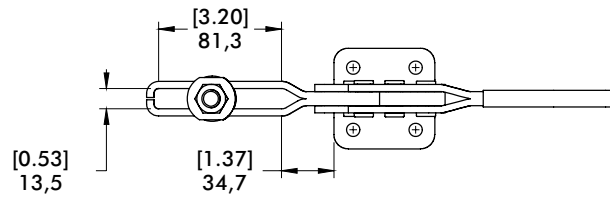

# 205 SERIES

## Horizontal Hold Down Clamps | Product Overview

### Features:

- Smallest of the Horizontal Hold Down clamps
- Ideal for light duty clamping in tight spaces
- Stainless steel models furnished without plastic grip

### Applications:

- Assembly
- Closures
- Woodworking
- Light duty clamping

### Also Available:

See page MC-ACC-1 for accessories  
Accommodates M4 or #8 spindle accessory

**205-U/USS**  
Flanged Base  
U-Bar



-USS Stainless Steel Model

**205-UB** ⓘ  
Straight Base  
U-Bar



**205-UL** ⓘ  
Left Flanged Base  
U-Bar



**205-UR** ⓘ  
Right Flanged Base  
U-Bar



**205-S/SSS**  
Flanged Base  
Solid Bar



-USS Stainless Steel Model

**205-SB** ⓘ  
Straight Base  
Solid Bar



**205-SL** ⓘ  
Left Flanged Base  
Solid Bar



**205-SR** ⓘ  
Right Flanged Base  
Solid Bar



## Technical Information

Model	Max. Holding Capacity	Clamp Bar Opening (+10°)	Handle Opening (+10°)	Weight	Accessories (Supplied)	
					Spindle Assembly	Flanged Washers
205-U	270 N [60 lbf]	90°	80°	0,03 kg [0.06 lb]	205208-M	105106
205-UB ⓘ						
205-UL ⓘ						
205-UR ⓘ	340 N [75 lbf]	94°	82°		205943-M	105906
205-USS						
205-S						
205-SB ⓘ	270 N [60 lbf]	94°	82°	205208-M	--	
205-SL ⓘ						
205-SR ⓘ						
205-SSS	340 N [75 lbf]				205943-M	

ⓘ This item is available upon request



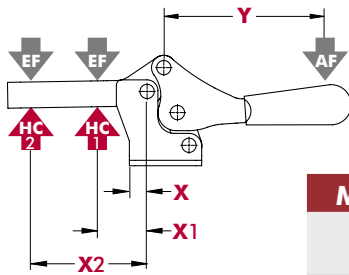

Model	X	X1	X2	Y	±HC1	±HC2	±EF(X1):AF	±EF(X2):AF
U		[0.43] 11			[60 lbf] 270 N	[50 lbf] 220 N	9:1	5:1
USS	[0.22] 5,6		[0.81] 20,5	[1.31] 33,2	[75 lbf] 340 N	[65 lbf] 290 N		
S		--			--	[60 lbf] 270 N	--	4:1
SSS						[75 lbf] 340 N		

Dimensions shown "mm [inch]" ± HC = Holding Capacity, EF = Exerting Force, AF = Applied Force  
See page MC-TEC-4 for additional information.

### Dimensions | -U/-UB/-UL-/-UR/-USS/-S/-SB/-SL/-SR/-SSS

**205-U**  
Flanged Base  
U-Bar

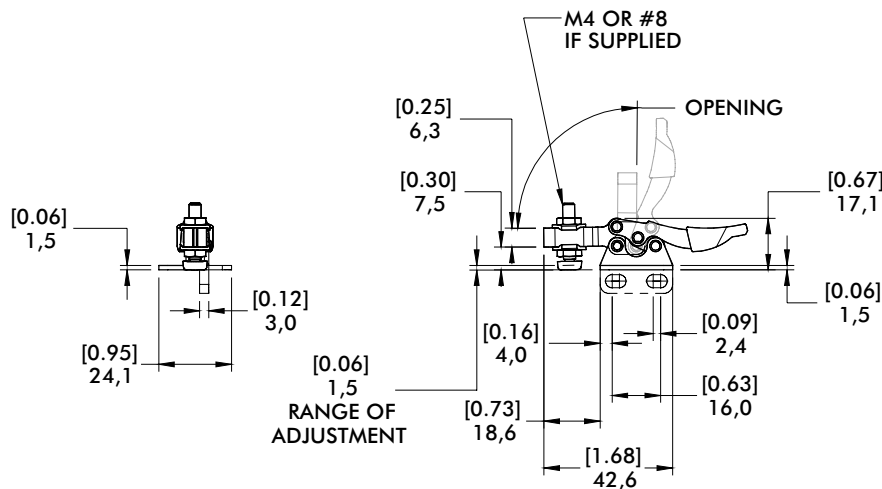
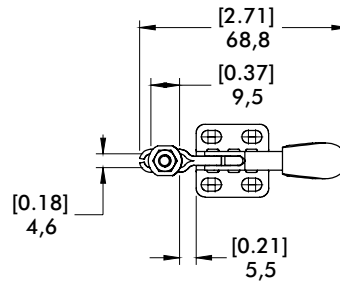

**205-S**  
Flanged Base  
Solid Bar

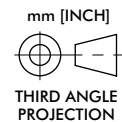
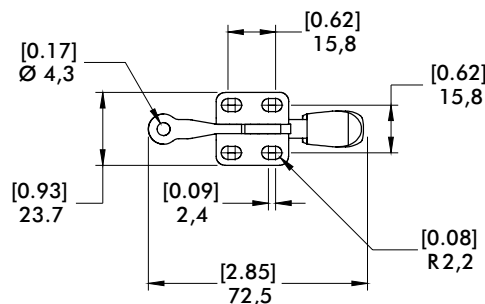

# 215 SERIES

## Horizontal Hold Down Clamps | Product Overview

### Features:

- Low profile
- Stainless steel model furnished without plastic grip

### Applications:

- Assembly
- Checking fixtures
- Closures
- Woodworking

### Also Available:

See page MC-ACC-1 for accessories  
Accommodates M6 or 1/4" spindle accessory

### 215-U/USS Flanged Base U-Bar



-USS Stainless Steel Model

### 215-UB ⓘ Straight Base U-Bar



### 215-S Flanged Base Solid Bar



## Technical Information

Model	Max. Holding Capacity	Clamp Bar Opening (+10°)	Handle Opening (+10°)	Weight	Accessories (Supplied)		
					Spindle Assembly	Flanged Washers	Bolt Retainer
215-U	890 N [200 lbf]	87°	78°	0,15 kg [0.34 lb]	202208-M	215105	--
215-USS	1110 N [250 lbf]				202943-M	215905	
215-UB ⓘ	890 N [200 lbf]				202208-M	215105	
215-S					--	--	205105

ⓘ This item is available upon request

## Holding Capacities

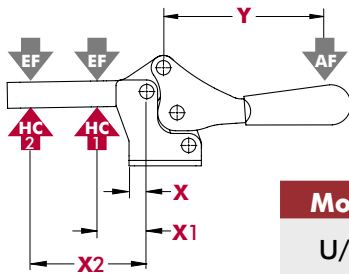

Model	X	X1	X2	Y	±HC1	±HC2	±EF(X1):AF	±EF(X2):AF
U/UB		[1.00] 25,4	[2.25] 57		[200 lbf] 890 N	[80 lbf] 360 N	9:1	4:1
USS	[0.22] 5,6			[2.72] 69	[250 lbf] 1110 N	[110 lbf] 490 N		
S		[1.63] 41,4	[2.88] 73		[200 lbf] 890 N		6:1	

Dimensions shown "mm [inch]" ± HC = Holding Capacity, EF = Exerting Force, AF = Applied Force  
See page MC-TEC-4 for additional information.

**215-U**  
Flanged Base  
U-Bar

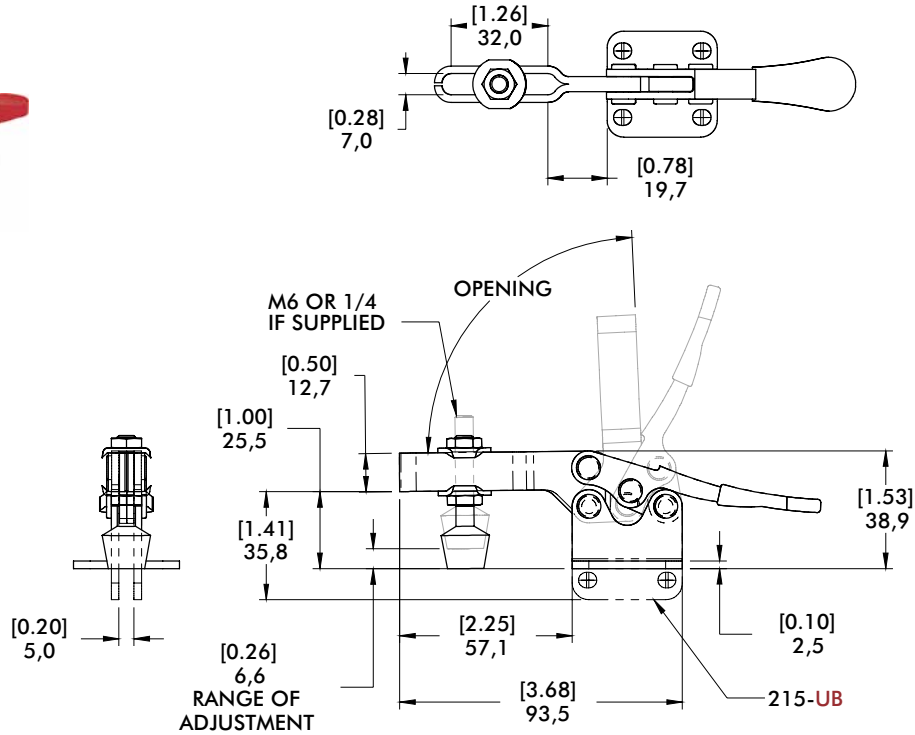

**215-S**  
Flanged Base  
Solid Bar

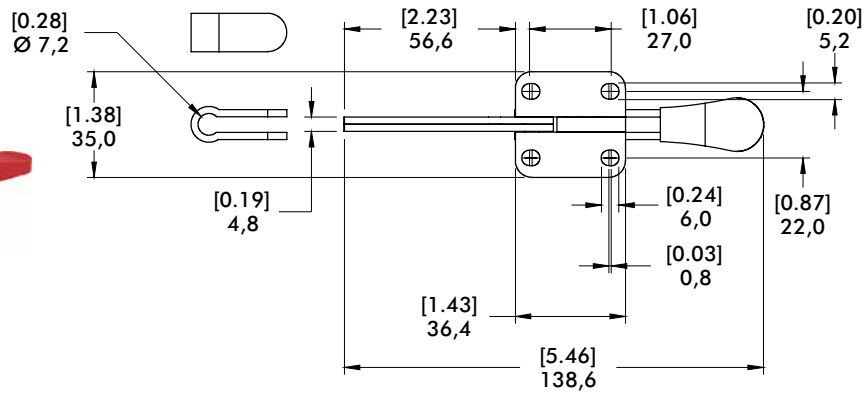

mm [INCH]  
THIRD ANGLE PROJECTION

# 225 SERIES

## Horizontal Hold Down Clamps | Product Overview

### Features:

- Low profile
- Stainless steel model furnished without plastic grip
- Available DESTACO® Toggle Lock Plus™

### Applications:

- Assembly
- Checking fixtures
- Closures
- Woodworking

### Also Available:

See page MC-ACC-1 for accessories  
Accommodates M8 or 5/16" spindle accessory

Covered under one or more U.S./International Patents

### 225-U/USS Flanged Base U-Bar



### 225-UR/URSS Flanged Base U-Bar DESTACO® Toggle Lock Plus



### 225-UB/UBSS① Straight Base U Bar



## Technical Information

Model	Max. Holding Capacity	Clamp Bar Opening (+10°)	Handle Opening (+10°)	Weight	Accessories (Supplied)	
					Spindle Assembly	Flanged Washers
225-U	2220 N [500 lbf]	92°	70°	0,25 kg [0.55 lb]	225208-M	507107
225-USS	2670 N [600 lbf]				207943-M	507907
225-UR	2220 N [500 lbf]			0,31 kg [0.69 lb]	225208-M	507107
225-URSS	2670 N [600 lbf]				207943-M	507907
225-UB①	2220 N [500 lbf]			0,25 kg [0.55 lb]	225208-M	507107
225-UBSS①	2670 N [600 lbf]				207943-M	507907

① This item is available upon request

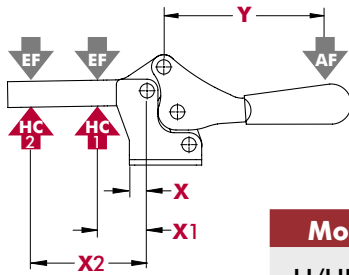

Model	X	X1	X2	Y	±HC1	±HC2	±EF(X1):AF	±EF(X2):AF
U/UR/UB	[0.12]	[1.25]	[2.50]	[3.56]	[500 lbf] 2220 N	[250 lbf] 1110 N	12:1	5:1
USS/URSS/ UBSS	3,0	31,8	63,5	90,4	[600 lbf] 2670 N	[300 lbf] 1340 N		

Dimensions shown "mm [inch]" ± HC = Holding Capacity, EF = Exerting Force, AF = Applied Force  
See page MC-TEC-4 for additional information.

### Dimensions | -U/-USS-/UB-/UBSS

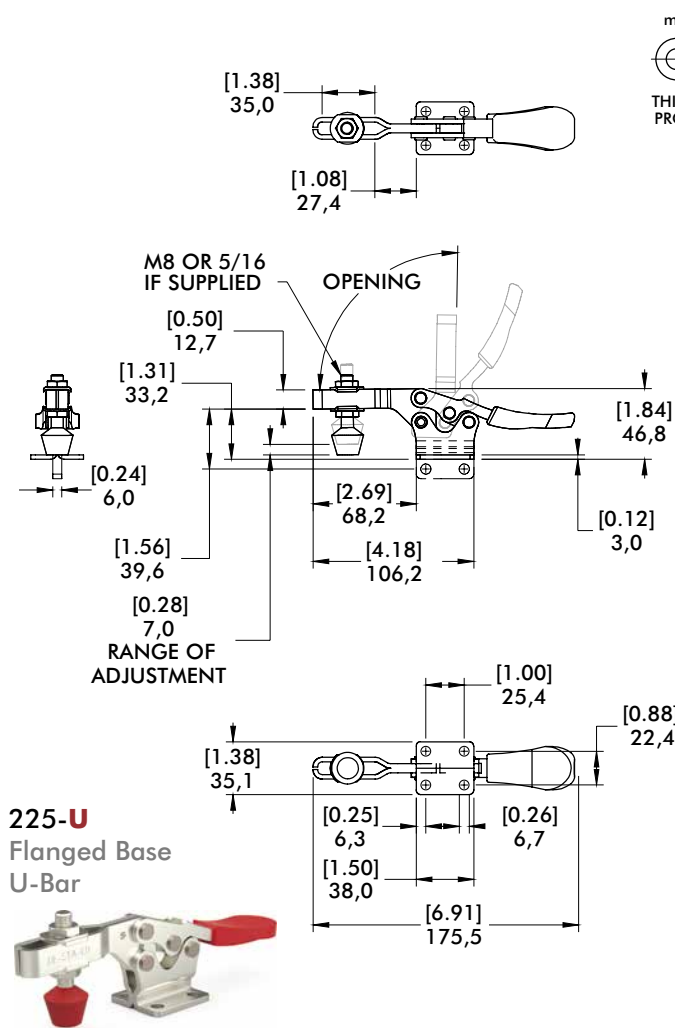

### Dimensions | -UR-/URSS

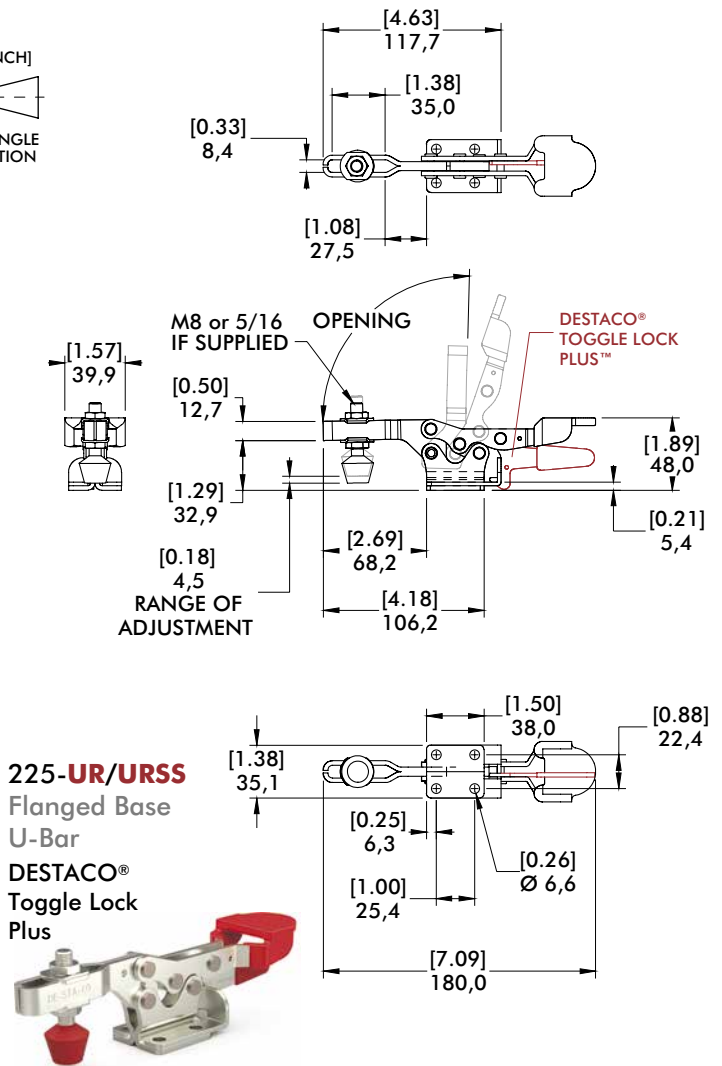
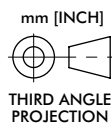

# 235 SERIES

## Horizontal Hold Down Clamps | Product Overview

### Features:

- Low profile
- Available DESTACO® Toggle Lock Plus™
- Available in stainless steel

### Applications:

- Assembly
- Checking fixtures
- Welding
- Closures
- Woodworking

### Also Available:

See page MC-ACC-1 for accessories  
Accommodates M10 or 3/8" spindle accessory

Covered under one or more U.S./International Patents

### 235-U/USS Flanged Base U-Bar



-USS Stainless Steel Model



### 235-UR/URSS Flanged Base U-Bar



-URSS Stainless Steel Model

DESTACO®  
Toggle Lock  
Plus



### 235-UB ⓘ Straight Base U Bar



## Technical Information

Model	Max. Holding Capacity	Clamp Bar Opening (+10°)	Handle Opening (+10°)	Weight	Accessories (Supplied)	
					Spindle Assembly	Flanged Washers
235-U	3340 N [750 lbf]	92°	70°	0,67 kg [1.47 lb]	240208-M	235106
235-USS	3780 N [850 lbf]				237943-M	235906
235-UR	3340 N [750 lbf]			240208-M	235106	
235-URSS	3780 N [850 lbf]			237943-M	235906	
235-UB ⓘ	3340 N [750 lbf]			0,67 kg [1.47 lb]	240208-M	235106

ⓘ This item is available upon request

## Holding Capacities

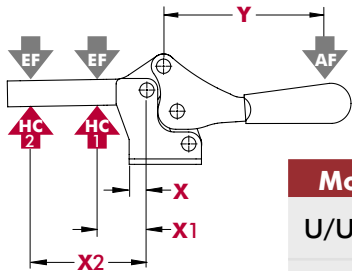

Model	X	X1	X2	Y	±HC1	±HC2	±EF(X1):AF	±EF(X2):AF
U/UR/UB	[0.25]	[1.75]	[4.13]	[5.75]	[750 lbf] 3340 N	[300 lbf] 1330 N	9:1	5:1
USS/URSS	6,4	44,5	105	146	[850 lbf] 3780 N	[360 lbf] 1600 N		

Dimensions shown "mm [inch]" ± HC = Holding Capacity, EF = Exerting Force, AF = Applied Force  
See page MC-TEC-4 for additional information.

### 235-U Flanged Base U-Bar

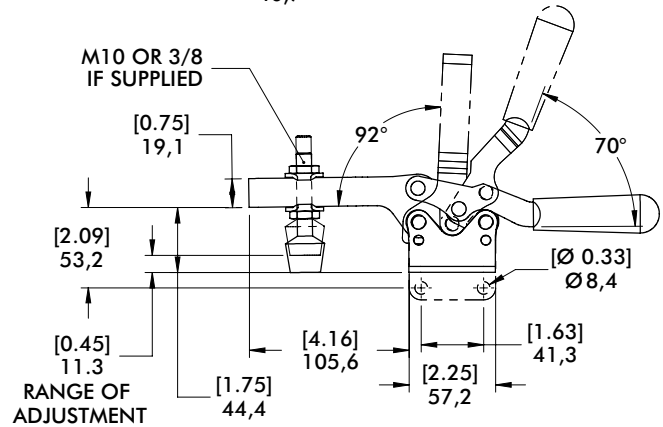
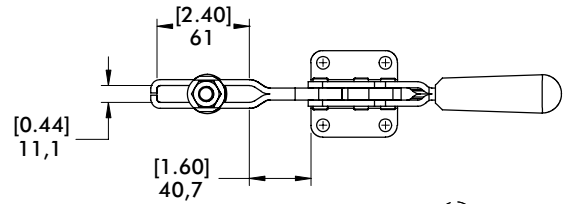
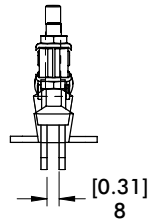

### Dimensions | -UR

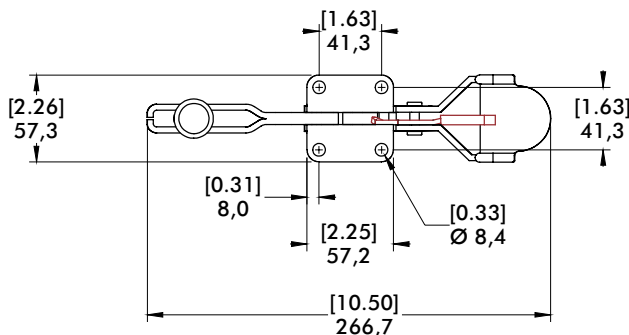
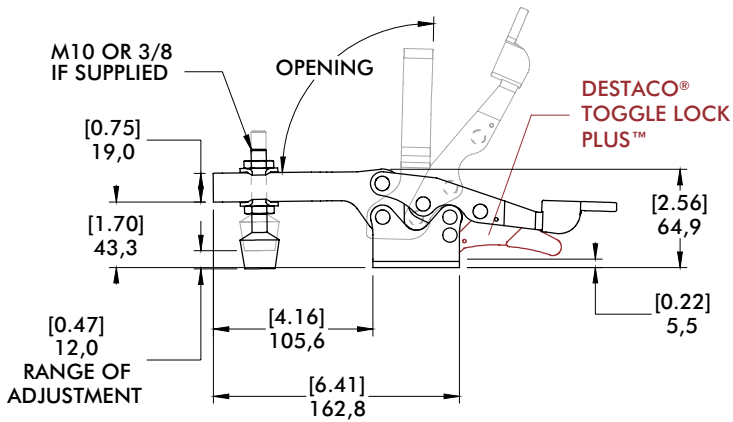
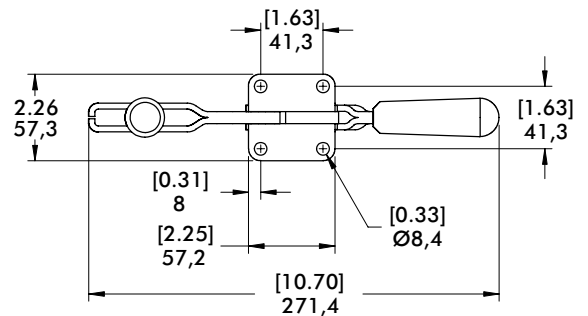
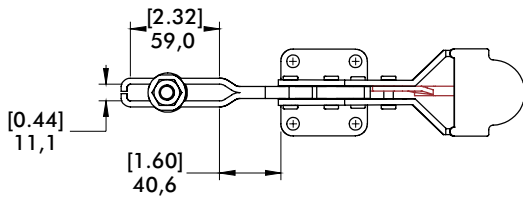

mm [INCH]  
THIRD ANGLE PROJECTION

### 235-UR Flanged Base U-Bar DESTACO® Toggle Lock Plus™



# 305, 307, 309 SERIES

## Horizontal Hold Down Clamps | Product Overview

### Features:

- Compact design suitable for use in confined spaces
- Available DESTACO® Toggle Lock Plus™
- Stainless steel models available

### Applications:

- Assembly & Test
- Light Machining
- Closures
- Woodworking

### Also Available:

See page MC-ACC-1 for accessories

**305-U/USS**  
Flanged Base  
U-Bar



-USS Stainless  
Steel Model



**305-UR/URSS**  
Flanged Base  
U-Bar



-URSS Stainless  
Steel Model

DESTACO®  
Toggle Lock  
Plus™



**307-U/USS**  
Flanged Base  
U-Bar



-USS Stainless  
Steel Model



**307-UR/URSS**  
Flanged Base  
U-Bar



-URSS Stainless  
Steel Model

DESTACO®  
Toggle Lock  
Plus™



**309-U/USS**  
Flanged Base  
U-Bar



-USS Stainless  
Steel Model



**309-UR①**  
Flanged Base  
U-Bar

DESTACO®  
Toggle Lock  
Plus™



## Technical Information

Model	Max. Holding Capacity	Clamp Bar Opening (+10°)	Handle Opening (+10°)	Weight	Accessories (Supplied)	
					Spindle Assembly	Flanged Washers
305-U	670 N [150 lbf]	90°	170°	0,06 kg [0.13 lb]	305208-M	102111
305-USS	900 N [200 lbf]				201943-M	102911
305-UR	670 N [150 lbf]				305208-M	102111
305-URSS	900 N [200 lbf]				201943-M	102911
307-U	1560 N [350 lbf]	92°	173°	0,24 kg [0.54 lb]	307208-M	507107
307-USS					207943-M	507907
307-UR					307208-M	507107
307-URSS					207943-M	507907
309-U	3340 N [750 lbf]	90°	168°	1,30 kg [0.59 lb]	309208	235106
309-USS					237943-M	235906
309-UR①					309208	235106

① This item is available upon request



# 305, 307, 309 SERIES

## Horizontal Hold Down Clamps | Holding Capacities

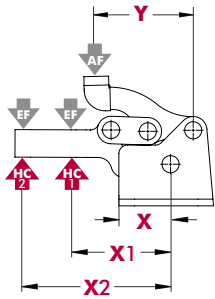

Model	X	X1	X2	Y	±HC1	±HC2	±EF(X1):AF	±EF(X2):AF
305-U/UR	[0.58]	[1.38]	[1.88]	[1.14]	[150 lbf] 670 N	[110 lbf] 490 N	3:1	2:1
305-USS/ 305-URSS	14,6	35	47,7	29	[200 lbf] 900 N	[150 lbf] 670 N		
307-U/UR/ USS/URSS	[0.94]	[1.88]	[2.50]	[1.77]	[350 lbf] 1560 N	[260 lbf] 1160 N	4:1	
309- U/UR/USS	[1.34]	[2.50]	[3.50]	[2.70]	[750 lbf] 3340 N	[530 lbf] 2360 N		

Dimensions shown "mm [inch]" ± HC = Holding Capacity, EF = Exerting Force, AF = Applied Force  
See page MC-TEC-4 for additional information.

## Dimensions | -U/-USS/-UR/-URSS

**305-U**  
Flanged Base  
U-Bar

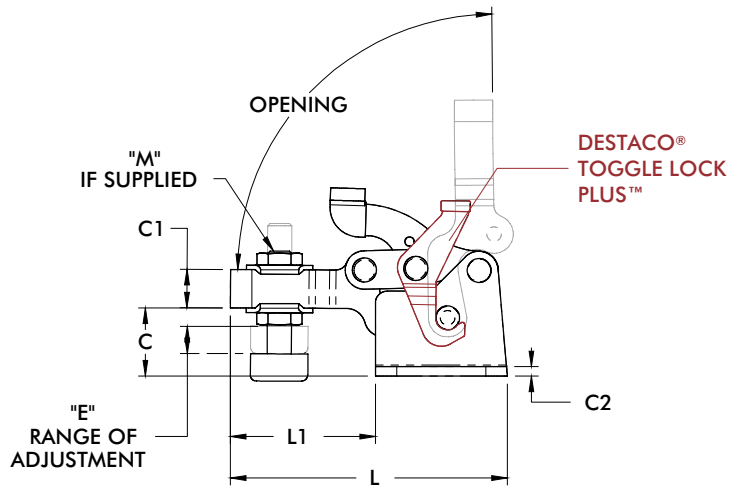
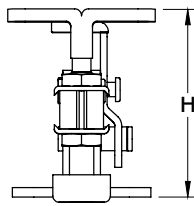
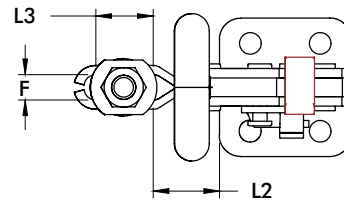

**307-UR**  
Flanged Base  
U-Bar

DESTACO®  
Toggle Lock  
Plus™

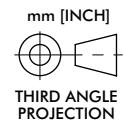
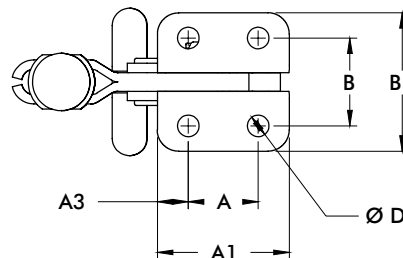

Model	A	A1	A3	B	B1	C	C1	C2	D	E	F	H	L	L1	L2	L3	M
305-U/UR	[0.53] 13,5	[1.035] 26,3	[0.25] 6,4	[0.62] 16,0	[1.02] 25,9	[0.48] 12,2	[0.31] 7,9	[0.08] 2,0	[0.18] 4,6	[0.31] 8	[0.21] 5,3	[1.43] 36,3	[2.21] 56,1	[1.19] 30,2	[0.51] 13,0	[0.50] 12,7	[#10] M5
307-U/UR	[0.91] 23,1	[1.72] 43,7	[0.40] 10,2	[1.14] 29,0	[1.80] 45,7	[0.89] 22,6	[0.50] 12,7	[0.12] 3,0	[0.28] 7,1	[0.37] 9,5	[0.33] 8,4	[2.36] 59,9	[3.61] 91,7	[1.89] 48,0	[0.86] 21,8	[0.75] 19,1	[5/16] M8
309-U/UR	[1.38] 35,1	[2.52] 64,0	[0.58] 14,7	[1.50] 38,1	[2.47] 62,7	[1.31] 33,3	[0.75] 19,1	[0.12] 3,0	[0.33] 8,4	[0.72] 18,5	[0.44] 10,4	[3.53] 89,7	[5.19] 131,8	[2.68] 68,1	[1.28] 32,5	[1.06] 26,9	[3/8-16] M10

# 206 SERIES

## Horizontal Hold Down Clamps | Product Overview

### Features:

- All stainless steel construction
- Offers good bar clearance under clamping bar while maintaining low profile

### Applications:

- Assembly
- Chemical processing
- Closures
- Light duty clamping

### Also Available:

See page MC-ACC-1 for accessories  
Accommodates M4 or #8 spindle accessory

#### 206-SS

Flanged Base  
Low U-Bar  
Stainless Steel



#### 206-HSS

Flanged Base  
High U-Bar  
Stainless Steel



## Technical Information

Model	Max. Holding Capacity	Clamp Bar Opening (+10°)	Handle Opening (+10°)	Weight	Accessories (Supplied)	
					Spindle Assembly	Flanged Washers
206-SS	440 N [100 lbf]	90°	90°	0,03 kg [0.07 lb]	205943-M	105906
206-HSS		85°*	85°*			

\*with spindle installed

Model 206-HSS shown securing a platen on a prototyping machine.

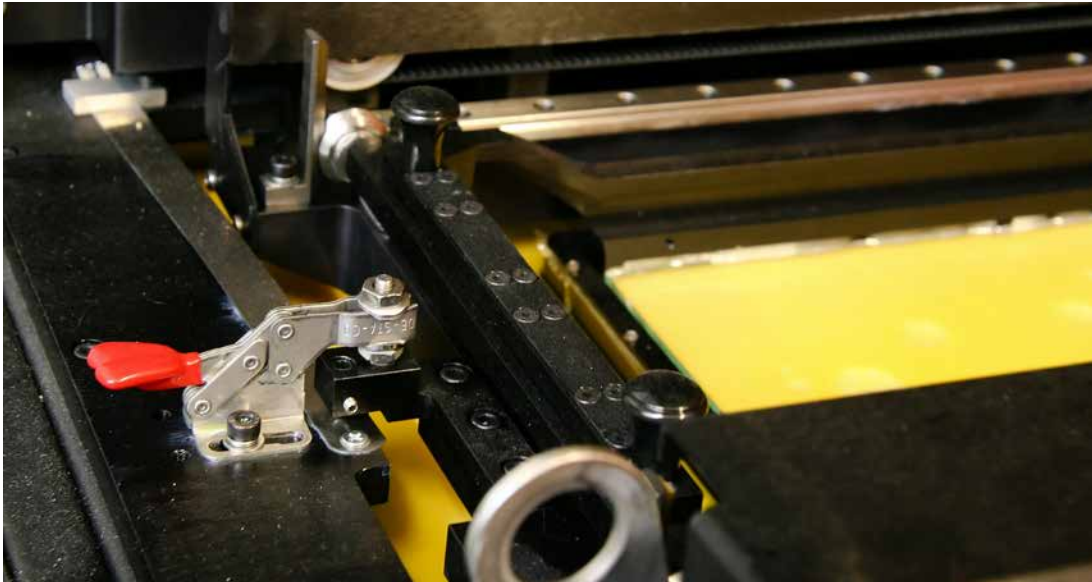

# 206 SERIES

## Horizontal Hold Down Clamps | Holding Capacities

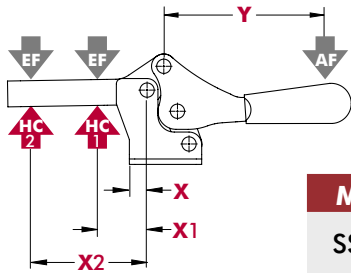

Model	X	X1	X2	Y	±HC1	±HC2	±EF(X1):AF	±EF(X2):AF
SS/HSS	[0.20] 5	[0.43] 11	[1.06] 27	[1.14] 29	[100 lbf] 440 N	[50 lbf] 220 N	5:1	3:1

Dimensions shown "mm [inch]" ± HC = Holding Capacity, EF = Exerting Force, AF = Applied Force  
See page MC-TEC-4 for additional information.

## Dimensions | -SS/-HSS

### 206-SS

Flanged Base  
Low U-Bar  
Stainless Steel

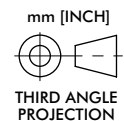
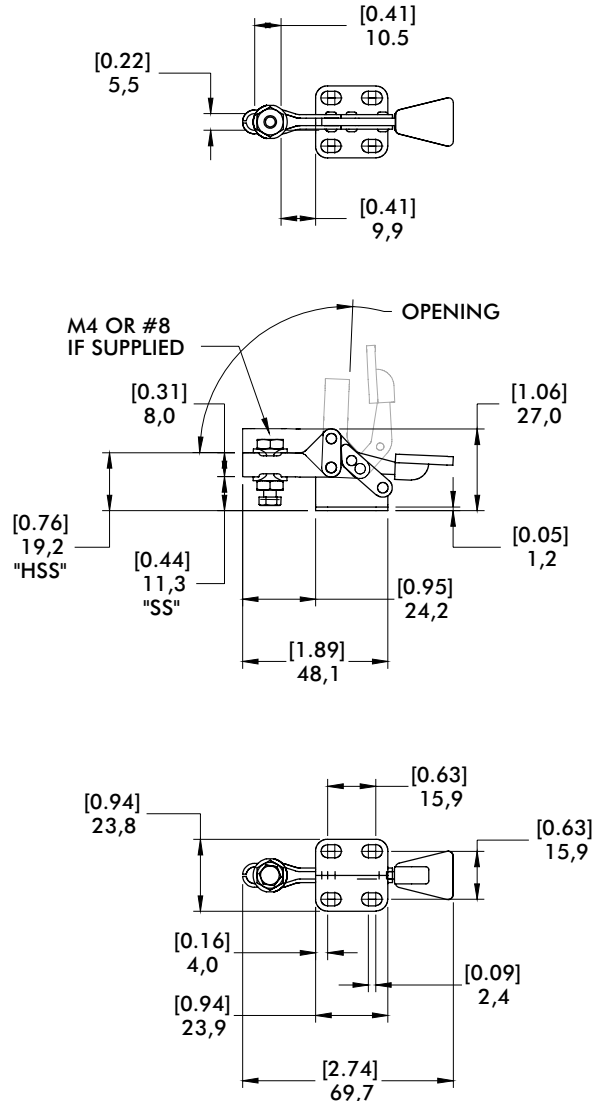

# 5305, 5310 SERIES

## Heavy Duty Horizontal Hold Down Clamps | Product Overview

### Features:

- Solid clamping arm may be modified to suit requirements
- Hardened steel pivot pins and bushings provide long life
- Black oxide finish
- DESTACO® Toggle Lock Plus™ versions available†

### Applications:

- Welding fixtures
- Assembly fixtures
- Light machining



5305/5310  
Flanged Base

5305-B/5310-B  
Solid  
Base

5305-R/5310-R  
Flanged Base  
DESTACO®  
Toggle Lock  
Plus™

5305-BRⓈ/5310-BRⓈ  
Solid Base  
DESTACO®  
Toggle Lock  
Plus™



## Technical Information

Model	Max. Holding Capacity	Clamp Bar Opening (+10°)	Handle Opening (+10°)	Weight
5305	[600 lbf] 2670 N	90°	69°	[1.08lbs] 0,49 kg
5305-B				[0.82lbs] 0,37 kg
5305-R				[1.09lbs] 0,49 kg
5305-BRⓈ				[0.83lbs] 0,37 kg
5310	[1300 lbf] 5780 N	90°	69°	[2.84lbs] 1,29 kg
5310-B				[2.24lbs] 1,02 kg
5310-R				[2.87lbs] 1,30 kg
5310-BRⓈ				[2.27lbs] 1,03 kg

Ⓢ This item is available upon request.

† Toggle Lock Plus™ locks the handle in the closed position only.

## Holding Capacities

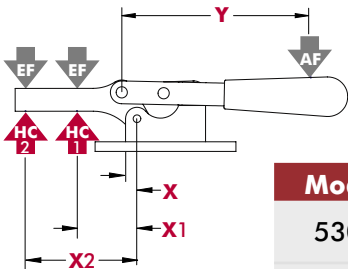

Model	X	X1	X2	Y	±HC1	±HC2	±EF(X1):AF	±EF(X2):AF
5305	[0.25] 6.3	[1.57] 40	[2.75] 70	[4.92] 125	[600 lbf] 2670 N	[340 lbf] 1500 N	10:1	5:1
5310	[0.38] 9.5	[1.97] 50	[3.66] 93	[6.10] 155	[1300 lbf] 5780 N	[675 lbf] 3000 N	10:1	8:1

Dimensions shown "mm [inch]" ± HC = Holding Capacity, EF = Exerting Force, AF = Applied Force  
See page MC-TEC-4 for additional information.

# 5305, 5310 SERIES

## Heavy Duty Horizontal Hold Down Clamps | Dimensions

5305/5310  
Flanged Base

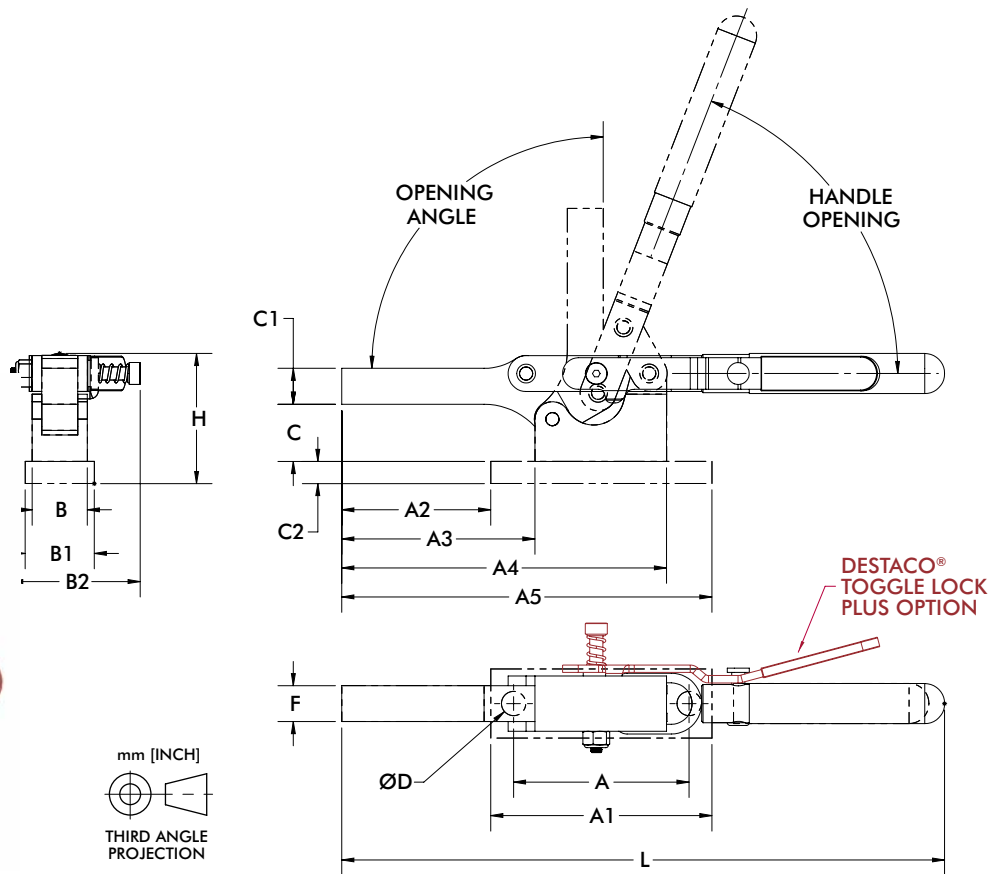

Model	A	A1	A2	A3	A4	A5	B	B1	B2	C	C1	C2	D	F	H	L
5305	[2.50] 63,5	[3.15] 80,0	[2.12] 53,8	[2.75] 69,9	[4.63] 117,6	[5.27] 133,9	[0.79] 20,1	[0.98] 24,9	--	[0.81] 20,6	[0.51] 13,0	[0.31] 7,9	[0.35] 8,9	[0.51] 13,0	[1.51] 38,4	[8.36] 212,4
5305-R									[1.84] 46,7							
5310	[3.63] 92,2	[4.63] 117,6	[2.63] 66,8	[3.63] 92,2	[6.25] 158,8	[7.25] 184,2	[1.13] 28,7	[1.50] 38,1	--	[1.00] 25,4	[0.75] 19,1	[0.31] 7,9	[0.41] 10,4	[0.79] 20,1	[2.00] 50,8	[11.13] 282,6
5310-R									[2.31] 58,7							[11.02] 279,8

Model	A3	A4	B2	C	C1	F	H	L
5305-B	[2.75] 69,9	[4.63] 117,6	--	[0.81] 20,6	[0.51] 13,0	[0.51] 13,0	[1.51] 38,4	[8.36] 212,4
5305-BR <sup>①</sup>			[1.84] 46,7					
5310-B	[3.63] 92,2	[6.25] 158,8	--	[1.00] 25,4	[0.75] 19,1	[0.79] 20,1	[2.35] 59,6	[11.13] 282,6
5310-BR <sup>①</sup>			[2.31] 58,7					[11.02] 279,8

<sup>①</sup> This item is available upon request

# 6001 SERIES

## Straight Line Action Clamps | Product Overview

### Features:

- Heavier duty version of Model 601 with 50% more holding capacity
- Mounting pattern interchangeable with Model 601
- Allow handle to fall below mounting plane to lock in retracted position

### Applications:

- Assembly
- Testing
- Soldering
- Gluing

### Also Available:

See page MC-ACC-1 for accessories

6001  
6001-M



6001-SS  
6001-MSS



## Technical Information | Holding Capacities | Dimensions

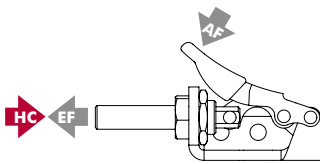

Model	Max. Holding Capacity	Weight	EF:AF (pushing/pulling)	Plunger Travel	(M) Plunger Thread	Spindle (Recommended)	Spindle Included
6001					#8-32	105203	No
6001-M	[150 lbf] 670 N	[0.12 lb] 0,05 kg	14:1/25:1	[0.63] 16	M4	205208-M	
6001-SS					#8-32	205943	Yes
6001-MSS					M4	205943-M	

HC = Holding Capacity, EF = Exerting Force, AF = Applied Force

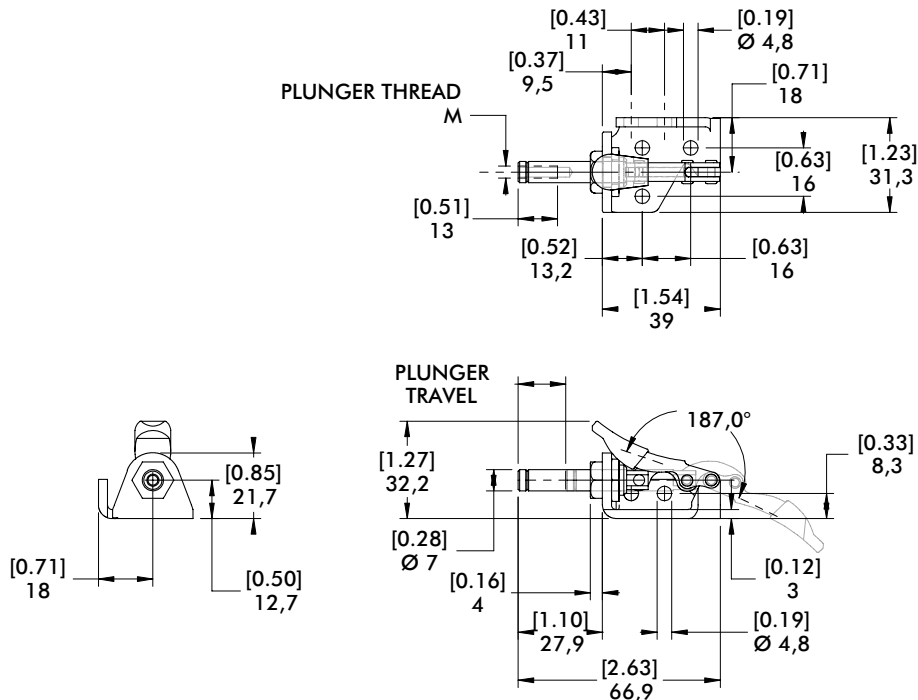

# 601 SERIES

## Straight Line Action Clamps | Product Overview

### Features:

- Compact straight line action clamp

### Applications:

- Assembly
- Testing
- Soldering
- Gluing

### Also Available:

See page MC-ACC-1 for accessories

601



601-M



601-O  
Straight Base  
U-Bar



601-SS  
Stainless steel



601-OSS ⓘ  
Stainless steel  
External  
thread



## Technical Information | Holding Capacities | Dimensions

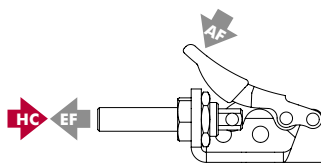

Model	Max. Holding Capacity	Weight	EF:AF (pushing/pulling)	Plunger Travel (M)	Plunger Thread (M)	Spindle (Recommended)	Spindle Included
601					#8-32	105203	Yes
601-M					M4	205208-M	No
601-O	[100 lbf] 440 N	[0.09 lb] 0,04 kg	14:1/25:1	[0.63] 16	1/4-20	--	No
601-SS					#8-32	205943	Yes
601-OSS ⓘ					1/4-20	--	No

ⓘ This item is available upon request HC = Holding Capacity, EF = Exerting Force, AF = Applied Force

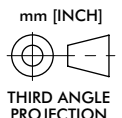
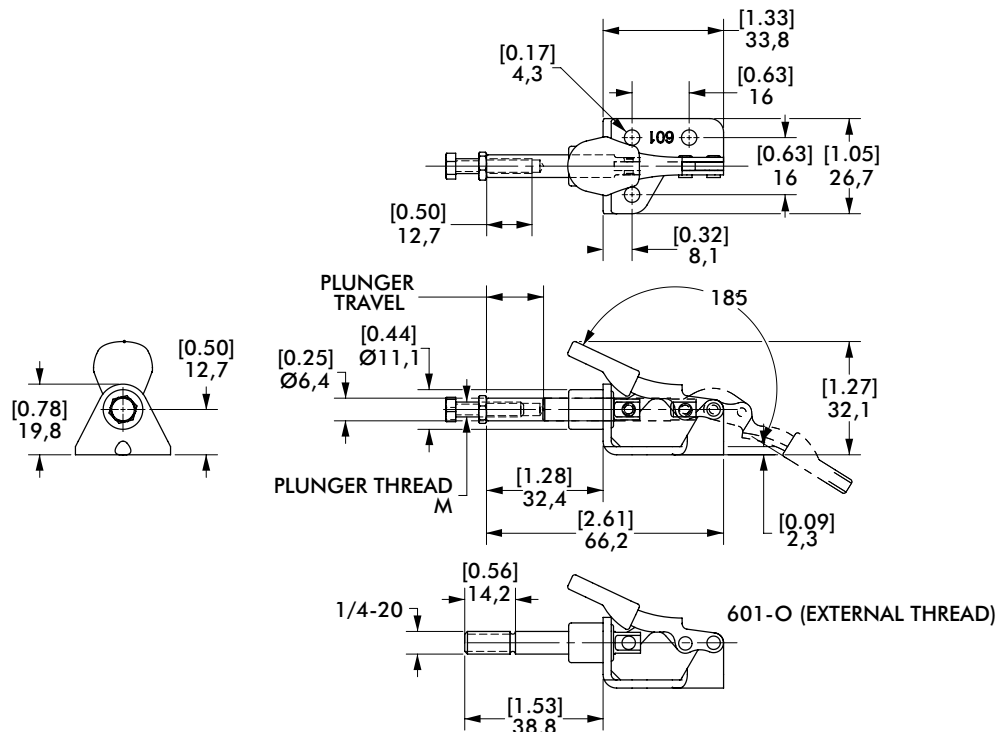

# 6015 SERIES

## Straight Line Action Clamps | Product Overview

### Features:

- Smallest of the solid base Straight Line Action clamps
- Compact design combined with high holding capacity
- Allow handle to fall below mounting plane to lock in retracted position

### Applications:

- Assembly
- Checking fixtures
- Tensioning devices

### Also Available:

See page MC-ACC-1 for accessories

Covered under one or more U.S./International Patents

6015  
6015-M



6015-SS,  
6015-MSS  
Stainless  
Steel



6015-R,  
6015-MR  
with DESTACO®  
Toggle Lock  
Plus™



## Technical Information | Holding Capacities

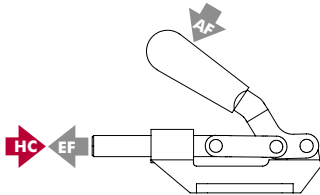

Model	Max. Holding Capacity	Weight	EF:AF (pushing)	Plunger Travel	(M) Plunger Thread	Recommended Spindle (Not Supplied)
6015	[560 lbf] 2500 N				1/4-20	205203
6015-M					M6	205203-M
6015-SS	[630 lbf] 2800 N	[0.35 lb] 0,15 kg	35:1	[0.70] 17,8	1/4-20	202943 (supplied)
6015-MSS					M6	202916-M (supplied)
6015-R	[560 lbf] 2500 N				1/4-20	205203
6015-MR					M6	205203-M

HC = Holding Capacity, EF = Exerting Force, AF = Applied Force



# 6015 SERIES

## Straight Line Action Clamps | Dimensions | -M/-SS/-MSS/-R/-MR

6015  
6015-M



6015-SS,  
6015-MSS  
Stainless  
Steel



6015-R,  
6015-MR  
with DESTACO®  
Toggle Lock Plus™

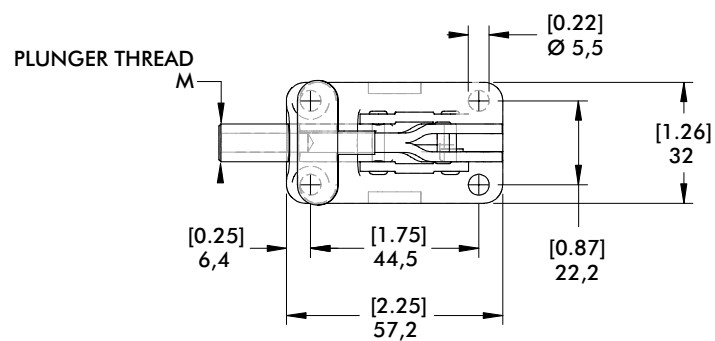

DESTACO®  
TOGGLE LOCK  
PLUS™ OPTION  
6015-R / 6015-MR  
(Engages in extended  
position only)

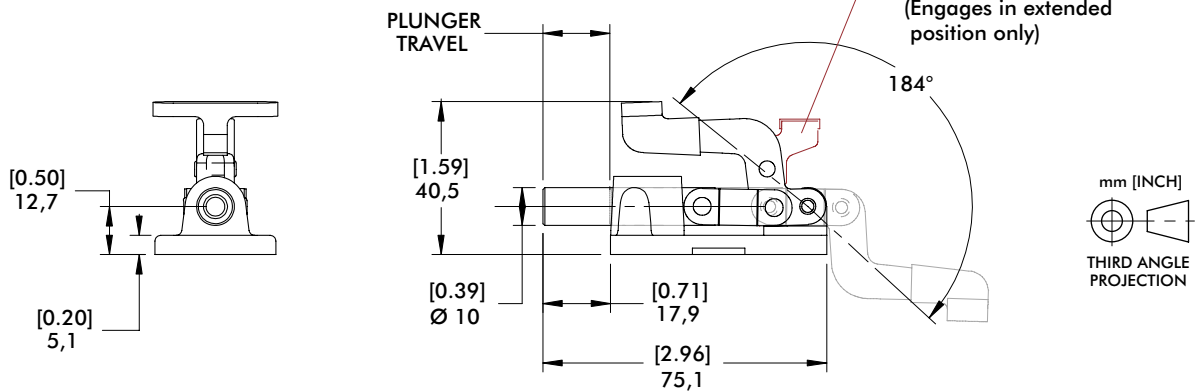

# 603, 608 SERIES

## Straight Line Action Clamps | Product Overview

### Features:

- Allow handle to rotate and fall below mounting plane to lock in retracted position
- Large holding capacities for their size
- Available with DESTACO® Toggle Lock Plus™

### Applications:

- Assembly & test
- Checking fixtures
- Welding fixtures
- Tensioning devices

### Also Available:

See page MC-ACC-1 for accessories

803 Pneumatic Toggle Clamp  
See page MC-PTC-23

803-ME Pneumatic Toggle Clamp  
See page MC-PTC-23

Covered under one or more U.S./International Patents

603  
603-M



603-SS  
603-MSS  
Stainless Steel



603-R  
603-MR  
with  
DESTACO®  
Toggle Lock  
Plus™



608  
608-M



## Technical Information | Holding Capacities

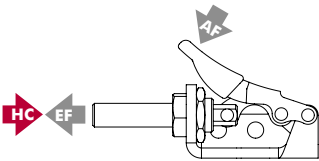

Model	Max. Holding Capacity	Weight	EF:AF (pushing/pulling)	Plunger Travel	(M) Plunger Thread	Recommended Spindle (Not Supplied)
603	[600 lbf] 2670 N				5/16-18	207203
603-M					M8	207203-M
603-SS	[840 lbf] 3740 N	[0.83 lb] 0,38 kg	23:1/34:1	[1.25] 31,8	5/16-18	207943
603-MSS					M8	207943-M (supplied)
603-R	[600 lbf] 2670 N				5/16-18	207203
603-MR					M8	207203-M
608	[850 lbf] 3780 N	[1.25 lb] 0,57 kg	44:1/50:1	[1.63] 41,3	3/8-16	210203
608-M					M10	210203-M

HC = Holding Capacity, EF = Exerting Force, AF = Applied Force

# 603, 608 SERIES

Straight Line Action Clamps | Dimensions | -M/-SS/-MSS/-R/-MR

603  
603-M



603-SS  
603-MSS  
Stainless Steel



603-R  
603-MR  
with  
DESTACO®  
Toggle Lock  
Plus™



608  
608-M

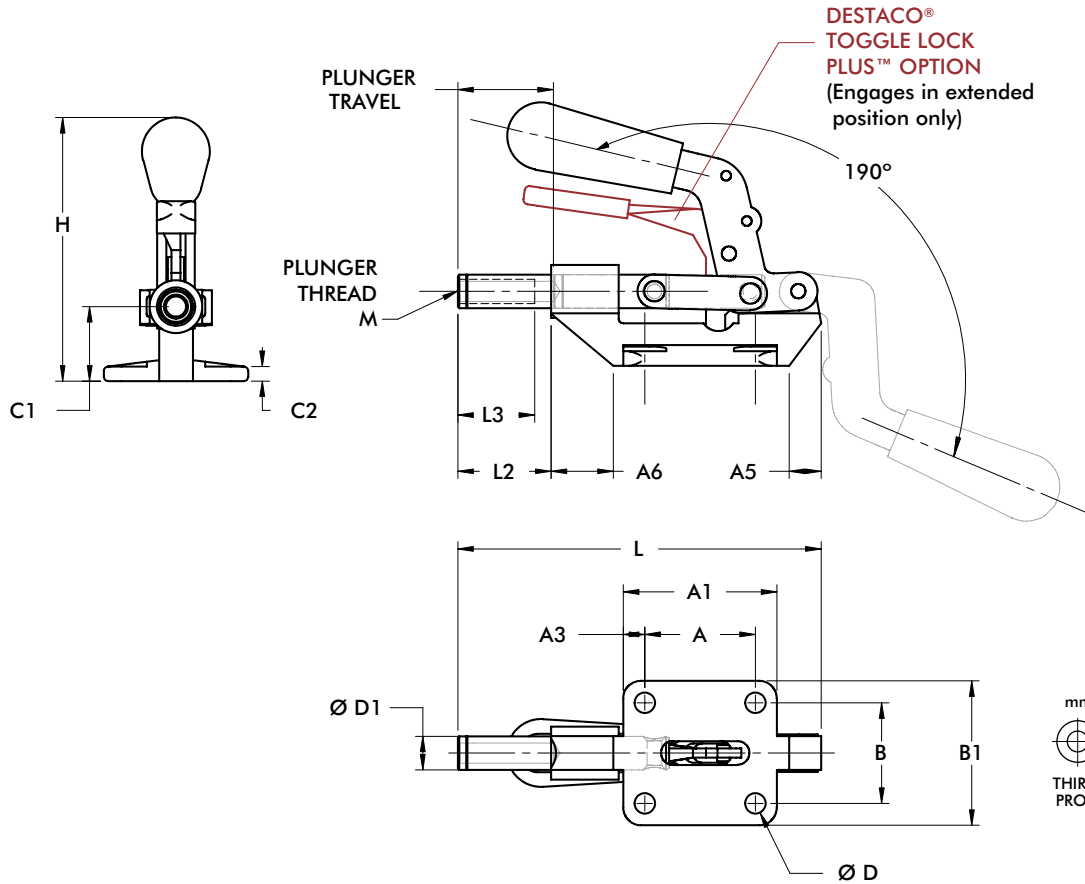

Model	A	A1	A3	A5	A6	B	B1	C1	C2	D	D1	H	L	L2	L3
603		[2.17]	[0.34]	[0.51]	[0.82]				[0.19]		[0.44]	[3.43]	[4.77]		
603-M		55	8,5	13	21				4,8		11,1	87	121,2		
603-SS	[1.44]			[0.54]	[0.65]	[1.31]	[1.88]	[0.97]	[0.25]	[0.27]	[0.47]	[3.28]	[4.69]	[1.28]	[1.00]
603-MSS	36,6			13,6	16,5	33,3	48	24,6	6,4	6,8	12	83,4	119,2	32,5	25,4
603-R		[2.20]	[0.30]	[0.51]	[0.82]						[0.44]	[3.43]	[4.77]		
603-MR		55,9	7,5	13	21						11,1	87	121,2		
608	[1.63]	[2.25]	[0.31]	[0.75]	[1.40]	[1.63]	[2.25]	[1.25]	[0.19]		[0.33]	[4.04]	[6.00]	[1.59]	[1.25]
608-M	41,4	57,2	8	19	36	41,4	57,2	31,8	4,8		8,4	102,6	152,3	40,5	31,8

# 605 SERIES

## Straight Line Action Clamps | Product Overview

### Features:

- For push/pull clamping
- Allow handle to rotate and fall below mounting plane to lock in retracted position

### Applications:

- Assembly & test
- Woodworking
- Tensioning devices

### Also Available:

See page MC-ACC-1 for accessories  
Reverse action version Model 615/615-M

605  
605-M



## Technical Information | Holding Capacities | Dimensions

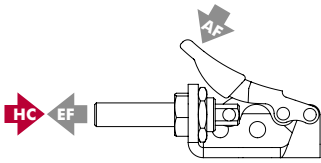

Model	Max. Holding Capacity	Weight	EF:AF (pushing/pulling)	Plunger Travel	(M) Plunger Thread	Recommended Spindle (Not Supplied)
605	[300 lbf] 1330 N	[0.69 lb] 0,31 kg	45:1/40:1	[1.25] 31,8	5/16-18	207203
605-M					M8	207203-M

HC = Holding Capacity, EF = Exerting Force, AF = Applied Force

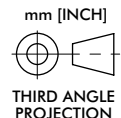
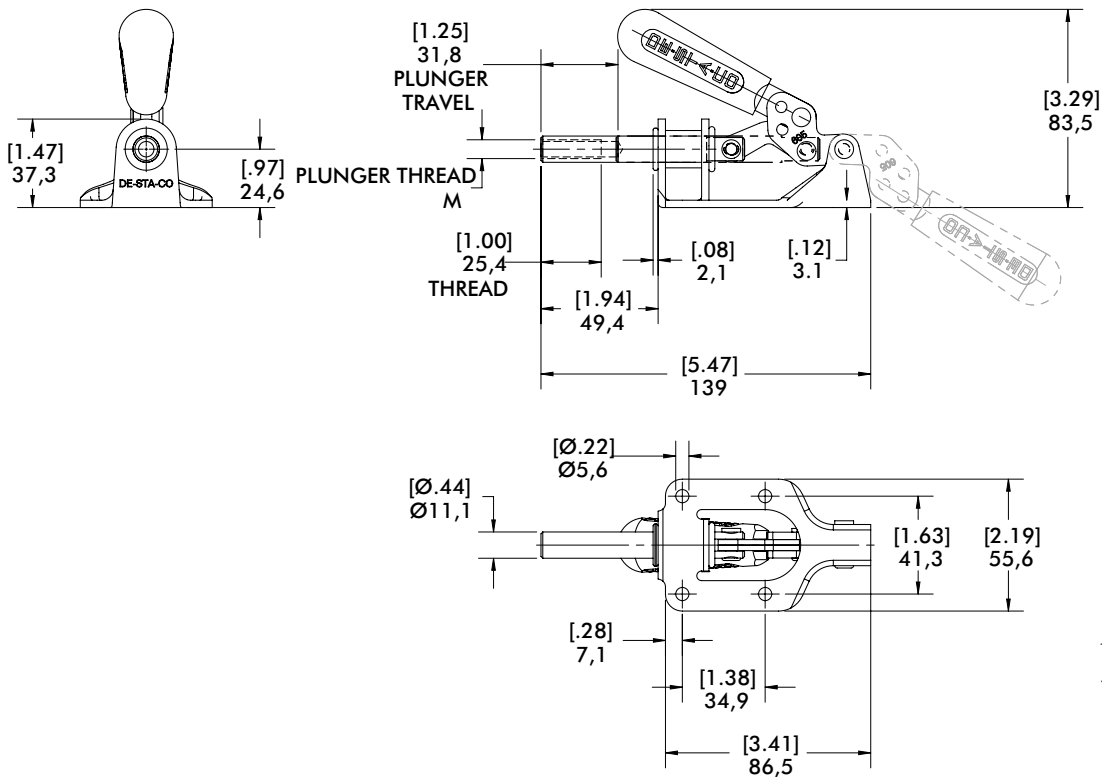

### Features:

- Handle and linkage swivel 125° for mounting flexibility
- Narrow base for tight spaces
- Plunger locks in extended position only

### Applications:

- Assembly & test
- Woodworking
- Tensioning devices

### Also Available:

See page MC-ACC-1 for accessories

606  
606-M



Mounting configuration:

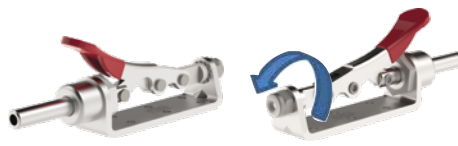

Bottom Mount



Side Mount

## Technical Information | Holding Capacities | Dimensions

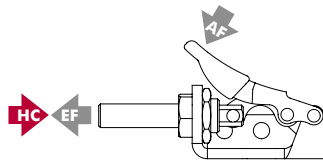

Model	Max. Holding Capacity	Weight	EF:AF (pushing)	Plunger Travel	(M) Plunger Thread	Recommended Spindle (Not Supplied)
606	[450 lbf] 2000 N	[0.81 lb] 0,37 kg	33:1	40 [1.57]	5/16-18 M8	207203
606-M						207203-M

HC = Holding Capacity, EF = Exerting Force, AF = Applied Force

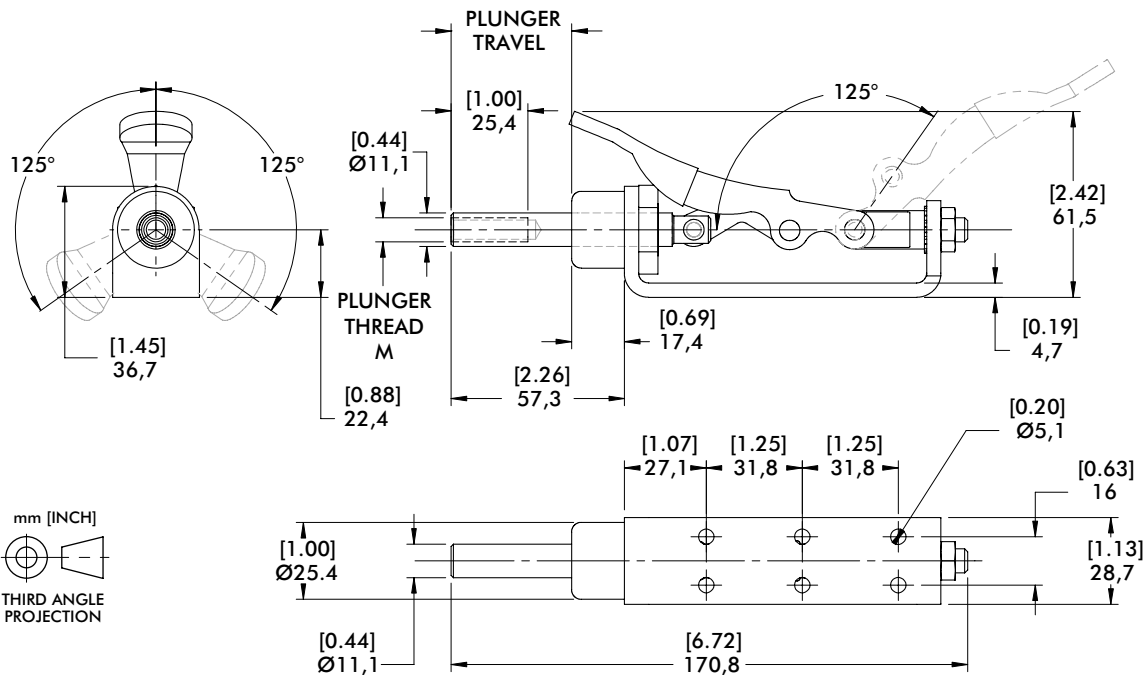

# 607 SERIES

## Straight Line Action Clamps | Product Overview

### Features:

- Low profile and high holding capacity for its size
- Available with round or square plunger to resist torsional loads
- Allow handle to rotate and fall below mounting plane to lock in retracted position

### Applications:

- Assembly & test
- Welding
- Tensioning devices

### Also Available:

See page MC-ACC-1 for accessories

607  
607-M



607-SQ  
607-SQM  
with Square  
Plunger



## Technical Information | Holding Capacities | Dimensions

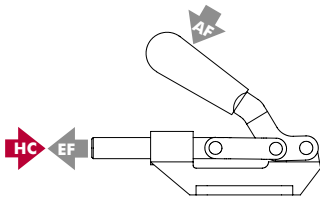

Model	Max. Holding Capacity	Weight	EF:AF (pushing/pulling)	Plunger Travel	(M) Plunger Thread	Recommended Spindle (Not Supplied)
607					5/16-18	207203
607-M	[800 lbf] 3560 N	[1.63 lb] 0,74 kg	37:1/64:1	[1.63] 41,4	M8	207203-M
607-SQ					5/16-18	207203
607-SQM					M8	207203-M

HC = Holding Capacity, EF = Exerting Force, AF = Applied Force

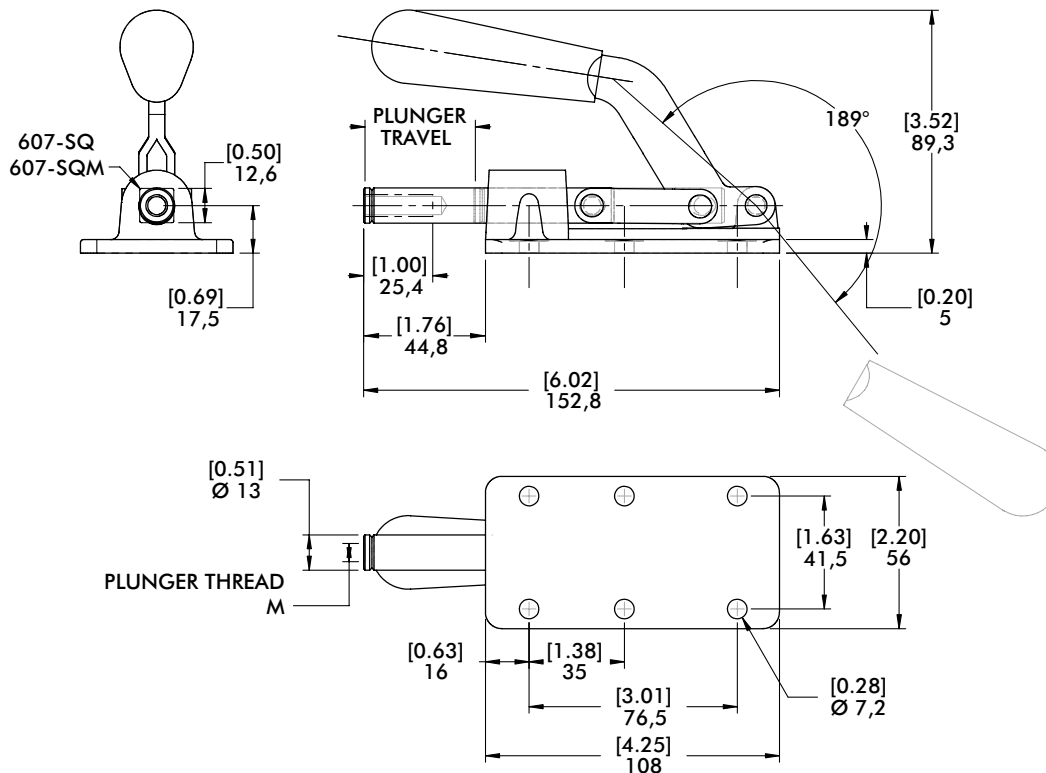

### Features:

- Low profile and high holding capacity for its size
- Flanged or straight base
- Allow handle to rotate and fall below mounting plane to lock in retracted position

### Applications:

- Assembly & test
- Welding
- Tensioning devices

### Also Available:

See page MC-ACC-1 for accessories

**609**  
Flanged Base



**609-B**  
Straight Base



## Technical Information | Holding Capacities | Dimensions

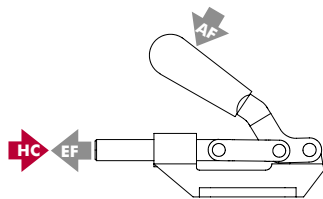

Model	Max. Holding Capacity	Weight	EF:AF (pushing/pulling)	Plunger Travel	(M) Plunger Thread	Recommended Spindle (Not Supplied)
609	[300 lbf] 1330 N	[0.88 lb] 0,40 kg	36:1/47:1	[1.25] 31,8	5/16-18	207203
609-B						

HC = Holding Capacity, EF = Exerting Force, AF = Applied Force

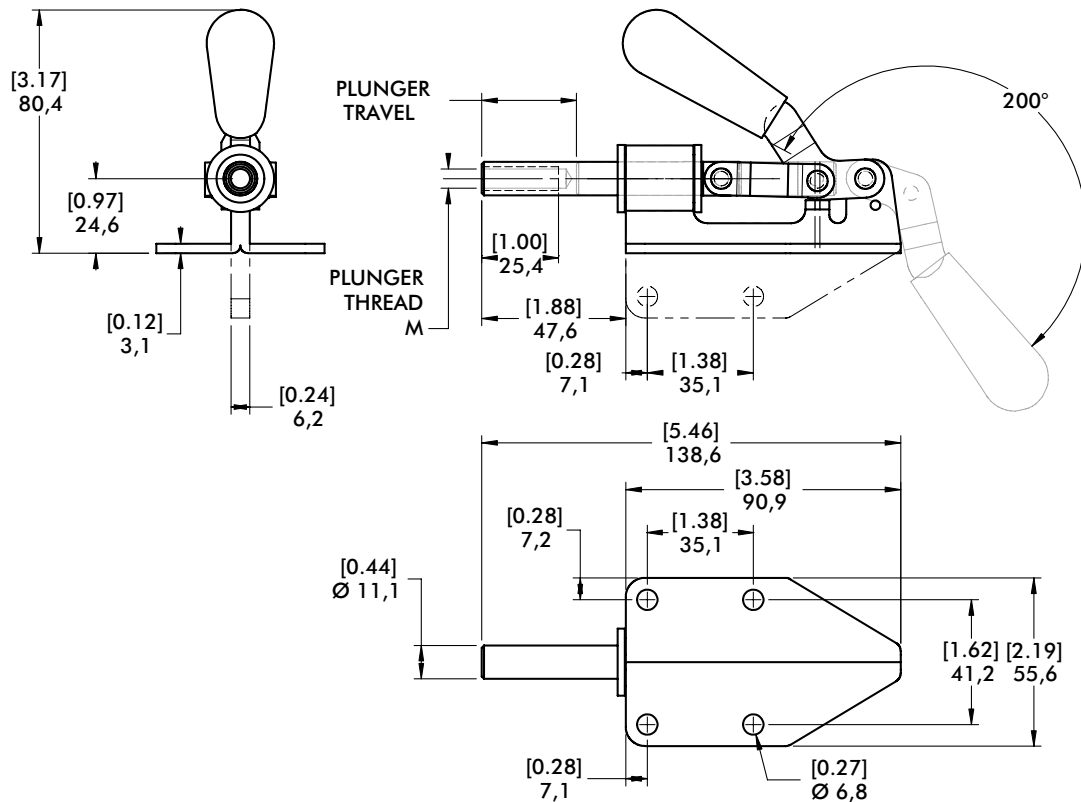

# 610 SERIES

## Straight Line Action Clamps | Product Overview

### Features:

- For push/pull clamping
- Allow handle to rotate and fall below mounting plane to lock in retracted position

### Applications:

- Assembly & test
- Woodworking
- Tensioning devices

### Also Available:

See page MC-ACC-1 for accessories

610  
610-M



## Technical Information | Holding Capacities | Dimensions

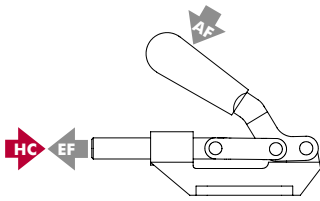

Model	Max. Holding Capacity	Weight	EF:AF (pushing/pulling)	Plunger Travel	(M) Plunger Thread	Recommended Spindle (Not Supplied)
610	[800 lbf] 3560 N	[1.69 lb] 0,77 kg	51:1/70:1	[1.63] 41,4	3/8-16	210203
610-M					M10	210203-M

HC = Holding Capacity, EF = Exerting Force, AF = Applied Force

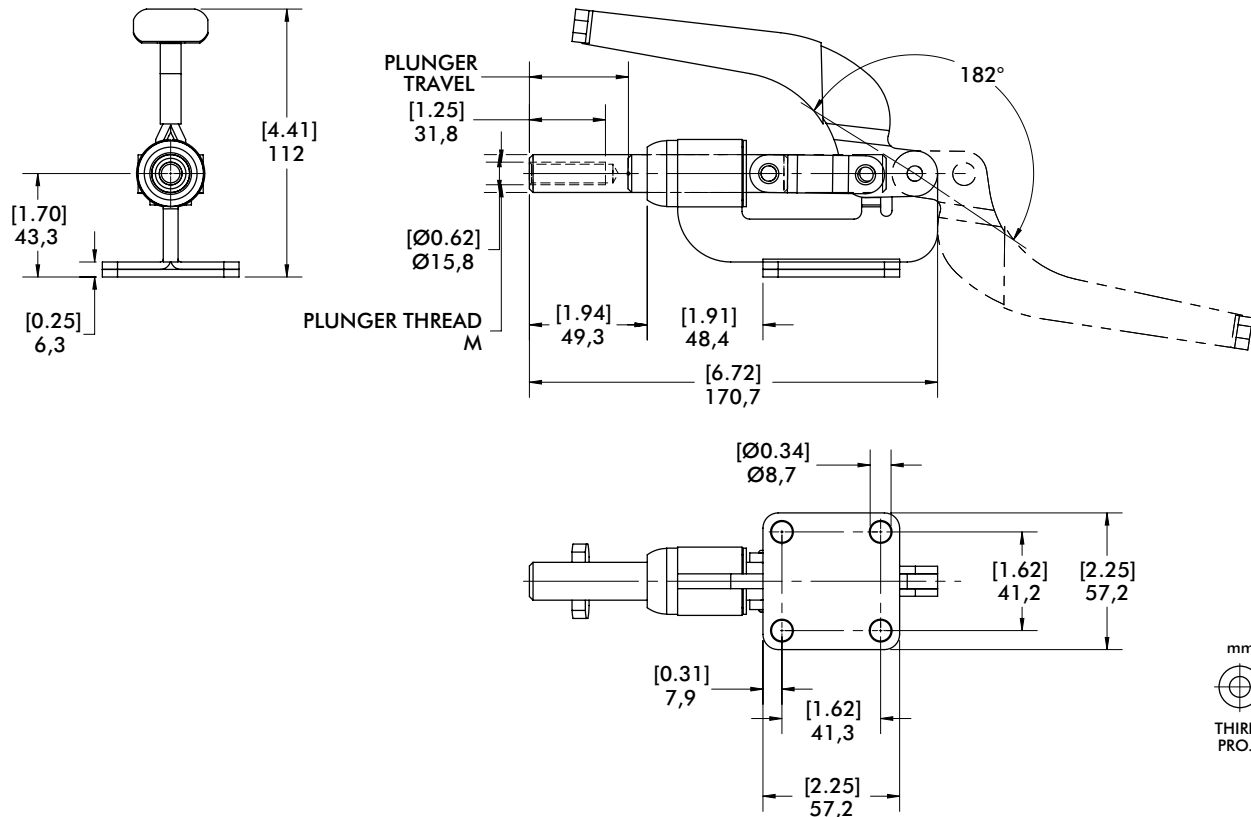



### Features:

- Reverse handle action.
- Plunger locks in the extended position only as the handle is moved downward

### Applications:

- Assembly & test
- Woodworking
- Tensioning devices

### Also Available:

See page MC-ACC-1 for accessories

615



## Technical Information | Holding Capacities | Dimensions

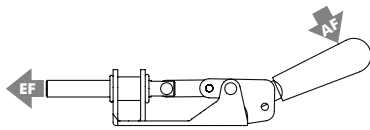

Model	Max. Holding Capacity	Weight	EF:AF (pushing)	Plunger Travel	(M) Plunger Thread	Recommended Spindle (Not Supplied)
615	[300 lbf] 1330 N	[0.69 lb] 0,31 kg	25:1	[1.00] 25,4	5/16-18	207203

HC = Holding Capacity, EF = Exerting Force, AF = Applied Force

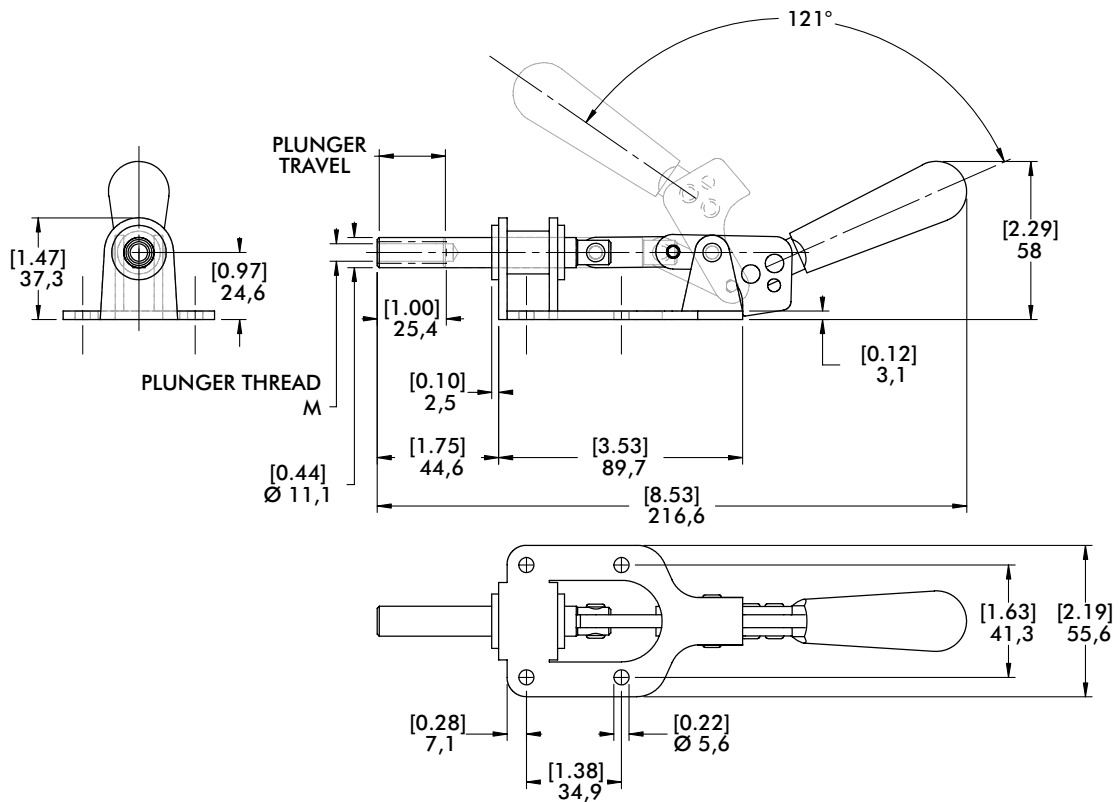

# 620 SERIES

## Straight Line Action Clamps | Product Overview

### Features:

- Reverse handle action
- Plunger locks in the extended position only as the handle is moved downward

### Applications:

- Assembly & test
- Woodworking
- Tensioning devices

### Also Available:

See page MC-ACC-1 for accessories

620  
620-M



## Technical Information | Holding Capacities | Dimensions

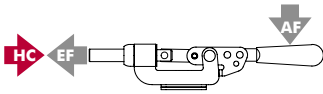

Model	Max. Holding Capacity	Weight	EF:AF (pushing)	Plunger Travel	(M) Plunger Thread	Recommended Spindle (Not Supplied)
620	[600 lbf] 2670 N	[1.50 lb] 0,68 kg	44:1	[1.11] 28,2	3/8-16	210203
620-M					M10	210203-M

HC = Holding Capacity, EF = Exerting Force, AF = Applied Force

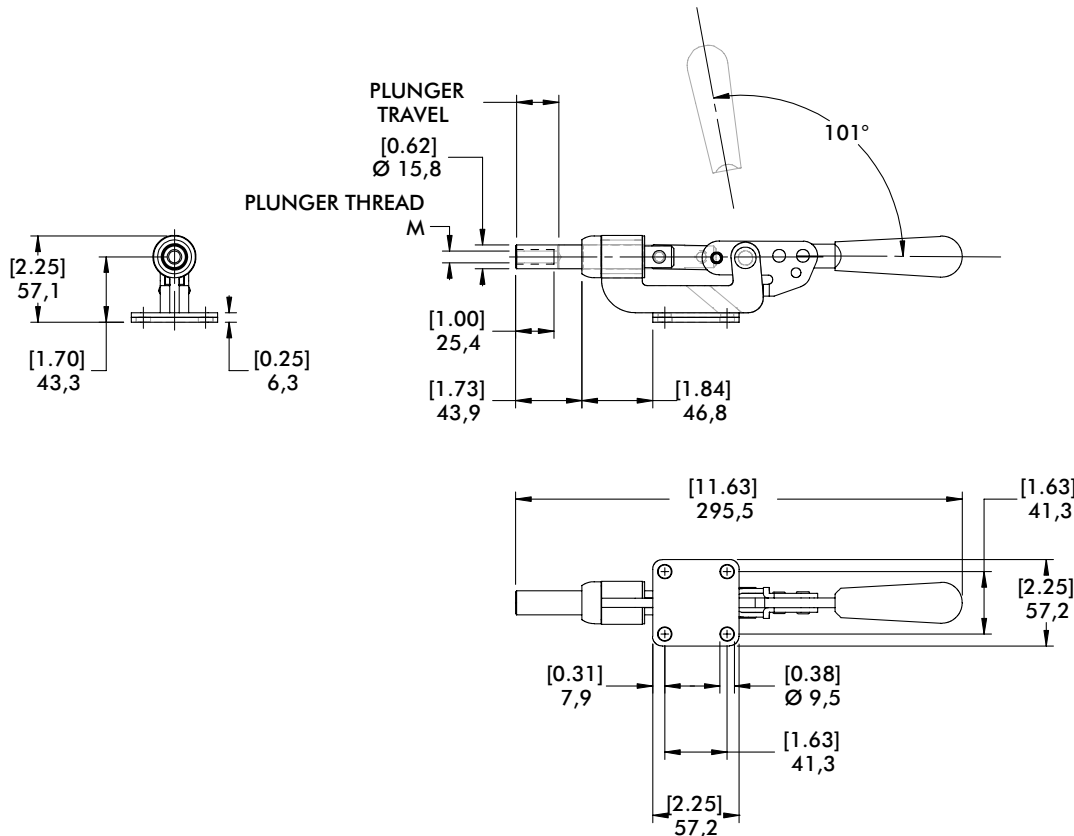

### Features:

- For push/pull clamping
- Allow handle to rotate and fall below mounting plane to lock in retracted position
- Available with DESTACO® Toggle Lock Plus™

### Applications:

- Assembly & test
- Welding
- Tensioning devices

### Also Available:

See page MC-ACC-1 for accessories  
830, 830-ME Pneumatic Toggle Clamp  
(See page MC-PTC-25)

630  
630-M



630-R  
630-MR  
with  
DESTACO®  
Toggle Lock  
Plus™



## Technical Information | Holding Capacities | Dimensions

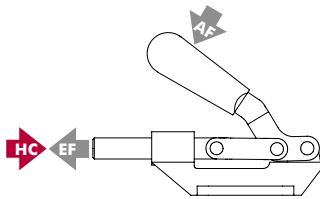

Model	Max. Holding Capacity	Weight	EF:AF (pushing/pulling)	Plunger Travel	(M) Plunger Thread	Recommended Spindle (Not Supplied)
630					3/8-16	210203
630-M	[2,500 lbf] 11100 N	[1.90 lb] 0,89 kg	36:1/23:1	[2.00] 50,8	M10	210203-M
630-R					3/8-16	210203
630-MR					M10	210203-M

HC = Holding Capacity, EF = Exerting Force, AF = Applied Force

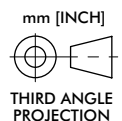
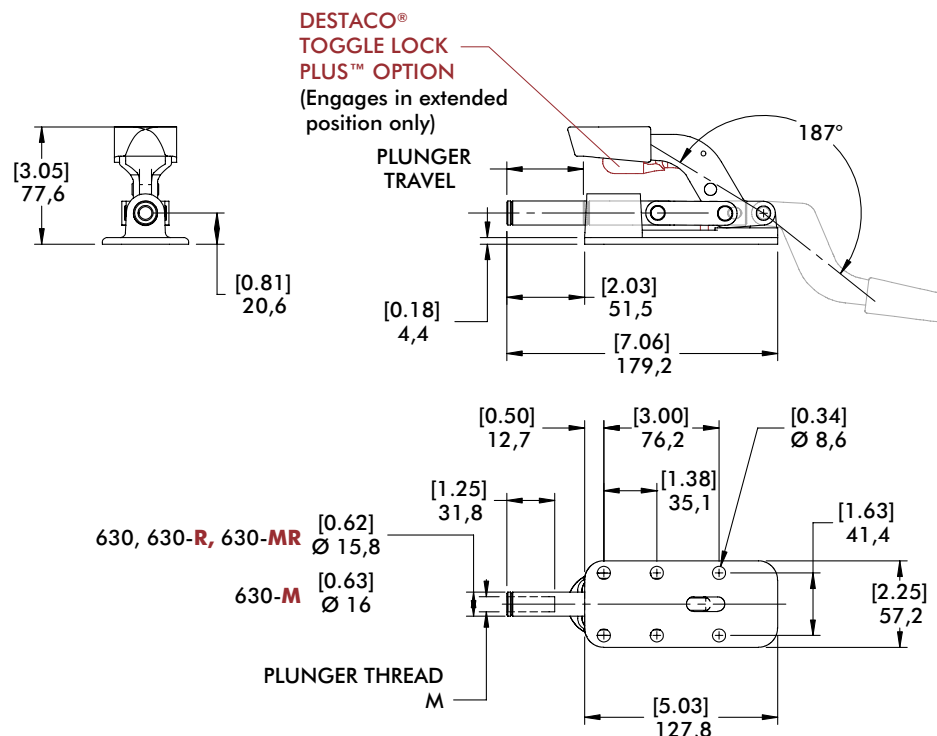

# 640 SERIES

## Straight Line Action Clamps | Product Overview

### Features:

- For heavy duty push/pull clamping
- Longest stroke of our Straight Line Action Clamps
- Allow handle to rotate and fall below mounting plane to lock in retracted position
- Available with DESTACO® Toggle Lock Plus™

### Applications:

- Assembly & test
- Welding
- Tensioning devices

### Also Available:

See page MC-ACC-1 for accessories

640  
640-M



640-R  
640-MR  
with  
DESTACO®  
Toggle Lock  
Plus™



## Technical Information | Holding Capacities | Dimensions

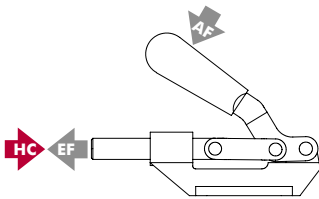

Model	Max. Holding Capacity	Weight	EF:AF (pushing)	Plunger Travel	(M) Plunger Thread	Recommended Spindle (Not Supplied)
640					1/2-13	220203
640-M	[7,500 lbf] 33400 N	[6.78 lb] 3,08 kg	35:1	[4.00] 101,6	M12	220203-M
640-R					1/2-13	220203
640-MR					M12	220203-M

HC = Holding Capacity, EF = Exerting Force, AF = Applied Force

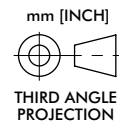
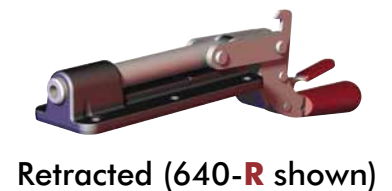
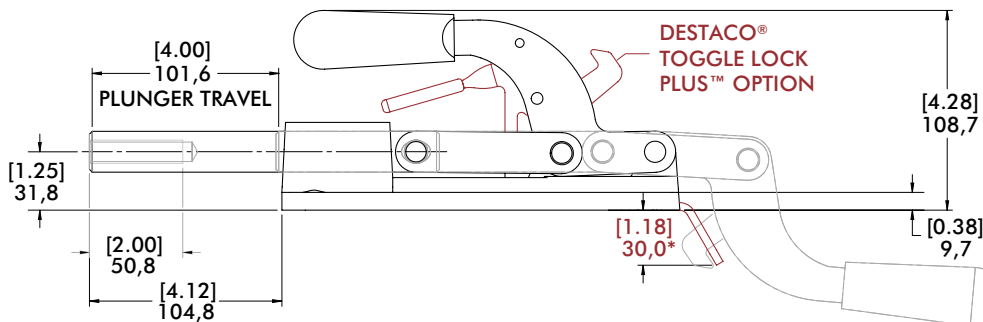
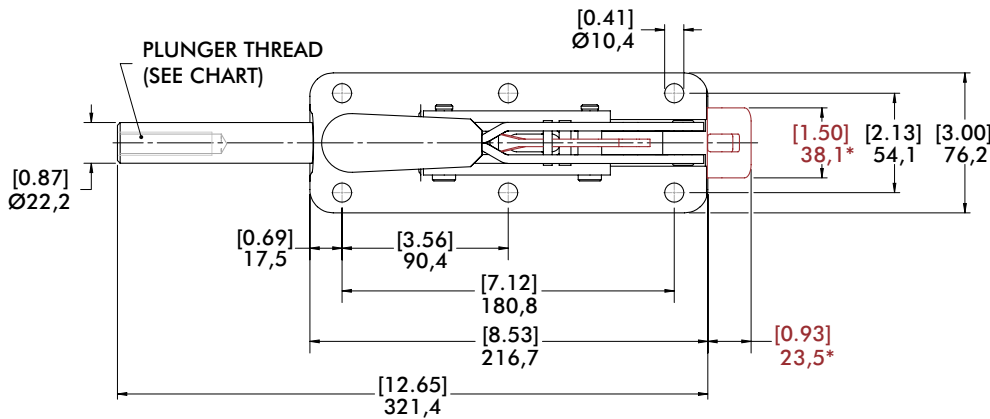

(\* Dimensions above in RED applies to the 640-R/640-MR only

### Features:

- For heavy duty push/pull clamping
- Largest of our Straight Line Action Clamps
- Forged steel base and handle
- Allow handle to rotate and fall below mounting plane to lock in retracted position

### Applications:

- Assembly
- Welding
- Staking, light presswork
- Tensioning devices

### Also Available:

See page MC-ACC-1 for accessories

650  
650-M



## Technical Information | Holding Capacities | Dimensions

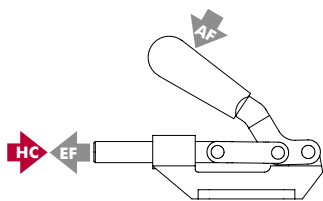

Model	Max. Holding Capacity	Weight	EF:AF (pushing)	Plunger Travel	(M) Plunger Thread	Recommended Spindle (Not Supplied)
650	[16,000 lbf] 71200 N	[5.69 lb] 2,58 kg	25:1	[3.00] 76,6	5/8-11	250203
650-M					M16	250203-M

HC = Holding Capacity, EF = Exerting Force, AF = Applied Force

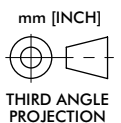
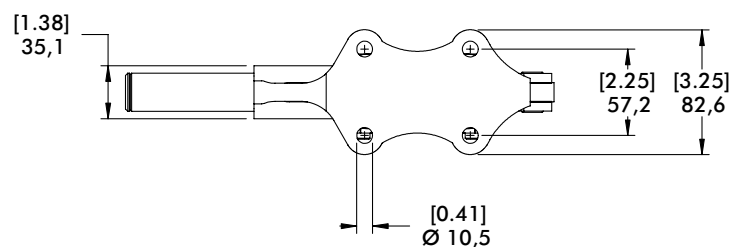
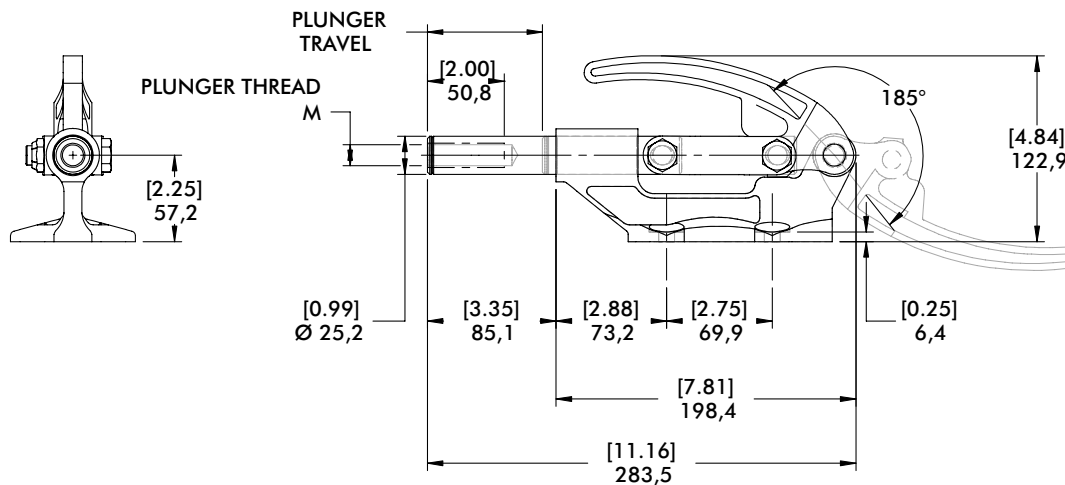

# 95030, 95040, 95050, 95060 SERIES

## Straight Line Action Clamps | Product Overview

### Features:

- Low profile with high holding capacities
- Cast steel base and handle
- Allow handle to rotate and fall below mounting plane to lock in retracted position

### Applications:

- Assembly
- Testing
- Tensioning devices

### Also Available:

See page MC-ACC-1 for accessories

95030

95040

95050 ⓘ

95060 ⓘ



## Technical Information | Holding Capacities

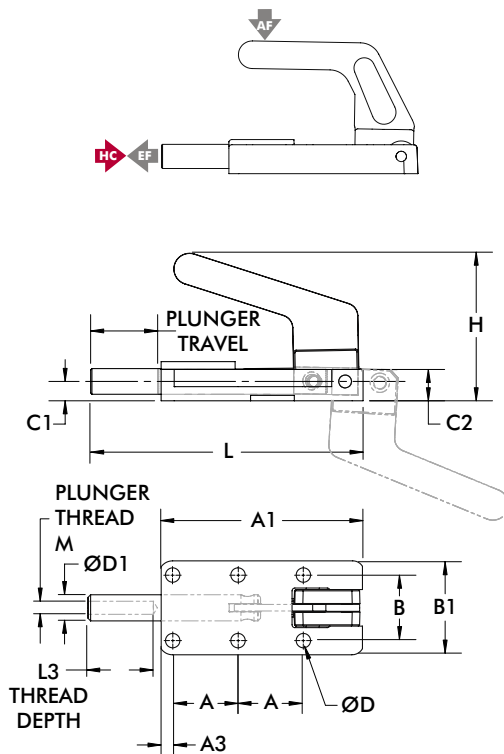

Model	Max. Holding Capacity	Weight	EF:AF (pushing)	Plunger Travel	(M) Plunger Thread	Recommended Spindle (Not Supplied)
95030	[550 lbf] 2450 N	[0.80 lb] 2,58 kg	15:1	[0.98] 24,9	M6	205203-M
95040	[1100 lbf] 4900 N	[1.60 lb] 0,73 kg	12:1	[1.50] 38,1	M8	207203-M
95050 ⓘ	[1650 lbf] 7340 N	[2.10 lb] 0,95 kg	15:1	[1.97] 50	M12	220203-M
95060 ⓘ	[3960 lbf] 17600 N	[6.4 lb] 2,9 kg	15:1	[2.36] 60		

ⓘ This item is available upon request

HC = Holding Capacity, EF = Exerting Force, AF = Applied Force

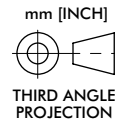

Part No.	A	A1	A3	B	B1	C1	C2	ØD	ØD1	H	L	L3*
95030	25 [0.98]	77 [3.03]	4.4 [0.17]	25 [0.98]	35.9 [1.41]	7.5 [0.30]	12.2 [0.48]	5.5 [0.22]	10 [0.39]	53.7 [2.11]	105 [4.13]	25 [0.98]
95040	35 [1.38]	109 [4.29]	7.9 [0.31]	35 [1.38]	50.7 [2.00]	10 [0.39]	18.3 [0.72]	6.5 [0.26]	14 [0.55]	77 [3.03]	149.1 [5.87]	35 [1.38]
95050 ⓘ	45 [1.77]	138.5 [5.45]	8.7 [0.34]	45 [1.77]	66 [2.60]	14 [0.55]	23.8 [0.94]	8.5 [0.33]	19 [0.75]	76.7 [3.02]	189.8 [7.47]	55 [2.17]
95060 ⓘ	55 [2.17]	167 [6.57]	10.2 [0.40]	55 [2.17]	77 [3.03]	16 [0.63]	27.4 [1.08]	10.5 [0.41]	22 [0.87]	93.8 [3.69]	229 [9.02]	65 [2.56]

ⓘ This item is available upon request

\*Minimum



# 5130, 5131, 5133 SERIES

## Heavy-Duty Straight Line Action Clamps | Product Overview

### Features:

- Reverse action allows the handle to stay out of the work zone
- Hardened steel pivot pins and bushings provide long life
- Black oxide finish with hardened plungers
- DESTACO® Toggle Lock Plus™ versions available

### Applications:

- Welding fixtures
- Assembly fixtures
- Light machining

5130/-M  
5131/-M  
5133/-M  
Flanged Base



5130-B/-MB  
5131-B/-MB  
5133-B/-MB  
Solid Base



5130-R/-MR  
5131-R/-MR  
5133-R/-MR  
Flanged Base with DESTACO® Toggle Lock Plus™



5130-BR①/-MBR①  
5131-BR①/-MBR①  
5133-BR①/-MBR①  
Solid Base with DESTACO® Toggle Lock Plus™



### Technical Information

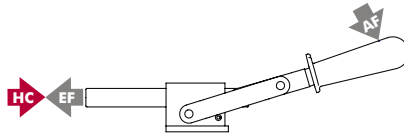

Model	Max. Holding Capacity	Weight	EF:AF (pushing)	Plunger Travel mm[in.]	Handle Opening	Plunger Thread (M)	Recommended Spindle (not supplied)
5131	[2500lbf.] 11120N	[1.12lbs] 0,51 kg	40:1	[1.00] 25,4	113°	5/16-18	461203
5131-M						M8	461203-M
5131-B		[0.85lbs] 0,39 kg				5/16-18	461203
5131-MB						M8	461203-M
5131-R		[1.15lbs] 0,52 kg				5/16-18	461203
5131-MR						M8	461203-M
5131-BR①		[0.88lbs] 0,40 kg				5/16-18	461203
5131-MBR①		M8	461203-M				
5130	[5800lbf.] 25800N	[2.87lbs] 1,30 kg	40:1	[1.75] 44,5	125°	1/2-13	325203
5130-M						M12	220203-M
5130-B		[2.40lbs] 1,09 kg				1/2-13	325203
5130-MB						M12	220203-M
5130-R		[3.03lbs] 1,37 kg				1/2-13	325203
5130-MR						M12	220203-M
5130-BR①		[2.56lbs] 1,16 kg				1/2-13	325203
5130-MBR①		M12	220203-M				
5133	[4600lbf.] 20460N	[3.12lbs] 1,41 kg	40:1	[3.18] 80,7	139°	1/2-13	325203
5133-M						M12	220203-M
5133-B		[2.65lbs] 1,20 kg				1/2-13	325203
5133-MB						M12	220203-M
5133-R		[3.36lbs] 1,52 kg				1/2-13	325203
5133-MR						M12	220203-M
5133-BR①		[2.89lbs] 1,31 kg				1/2-13	325203
5133-MBR①		M12	220203-M				

① This item is available upon request HC = Holding Capacity, EF = Exerting Force, AF = Applied Force



# 5130, 5131, 5133 SERIES

## Heavy-Duty Straight Line Action Clamps | Dimensions

mm [INCH]  
THIRD ANGLE PROJECTION

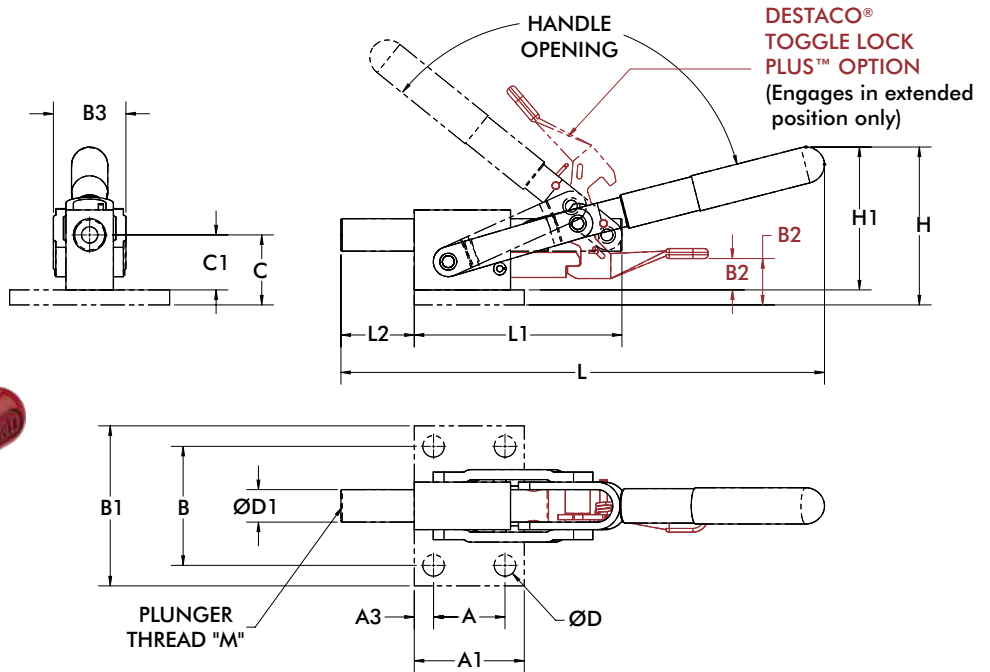

Model	A	A1	A3	B	B1	B2	B3	C	D	D1	H	L	L1	L2
5131						-								
5131-M	28.6	44	7.7	47.6	64		29	28	8.6	13	63.1	193.4	83	29.3
5131-R	[1.13]	[1.73]	[0.30]	[1.87]	[2.52]	18.5	[1.14]	[1.10]	[0.34]	[0.51]	[2.49]	[7.61]	[3.27]	[1.15]
5131-MR						[0.73]								
5130						-								
5130-M	44.5	64	9.8	58.7	76		40	35	10.5	19	92.3	283	132	49.7
5130-R	[1.75]	[2.52]	[0.38]	[2.31]	[2.99]	27.2	[1.57]	[1.38]	[0.41]	[0.75]	[3.63]	[11.14]	[5.20]	[1.96]
5130-MR						[1.07]								
5133						-								
5133-M	44.5	64	9.8	58.7	76		39	35	10.5	19	97.5	331.4	167	82.2
5133-R	[1.75]	[2.52]	[0.38]	[2.31]	[2.99]	31.4	[1.54]	[1.38]	[0.41]	[0.75]	[3.84]	[13.05]	[6.58]	[3.24]
5133-MR						[1.24]								

Model	B2	B3	C1	D1	H1
5131-B					
5131-MB	-	29	22	13	57.1
5131-BR ⓘ	12.4	[1.14]	[0.87]	[0.51]	[2.25]
5131-MBR ⓘ	[0.49]				
5130-B					
5130-MB	-	40	29	19	86.3
5130-BR ⓘ	21.2	[1.57]	[1.14]	[0.75]	[3.40]
5130-MBR ⓘ	[0.84]				
5133-B					
5133-MB	-	39	29	19	91.5
5133-BR ⓘ	25.4	[1.54]	[1.14]	[0.75]	[3.60]
5133-MBR ⓘ	[1.00]				

ⓘ This item is available upon request

# 5150 SERIES

## Heavy-Duty Straight Line Action Clamps | Product Overview

### Features:

- Square plunger provides positive radial location
- Reverse action allows the handle to stay out of the work zone
- Hardened steel pivot pins and bushings provide long life
- Black oxide finish with hardened plungers

### Applications:

- Welding fixtures
- Assembly fixtures
- Light machining

**5150/5150-M**  
Flanged Base



**5150-B/5150-MB**  
Solid Base



**5150-R/5150-MR**  
Flanged Base with DESTACO® Toggle Lock Plus™



**5150-BR①/5150-MBR①**  
Solid Base with DESTACO® Toggle Lock Plus™



### Technical Information

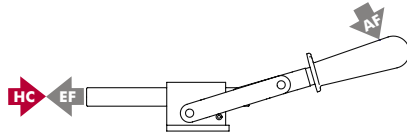

Model	Max. Holding Capacity	Weight	EF:AF (pushing)	Plunger Travel mm[in.]	Handle Opening	Plunger Thread (M)	Recommended Spindle (not supplied)
5150	[5800lbf.] 25800N	[3.00lbs] 1,36 kg	40:1	[1.91] 48.4	125°	1/2-13	325203
5150-M						M12	220203-M
5150-B		[2.50lbs] 1,13 kg				1/2-13	325203
5150-MB						M12	220203-M
5150-R		[3.15lbs] 1,43 kg				1/2-13	325203
5150-MR						M12	220203-M
5150-BR①		[2.68lbs] 1,22 kg				1/2-13	325203
5150-MBR①						M12	220203-M

① This item is available upon request **HC** = Holding Capacity, **EF** = Exerting Force, **AF** = Applied Force

# 5150 SERIES

## Heavy-Duty Straight Line Action Clamps | Product Overview

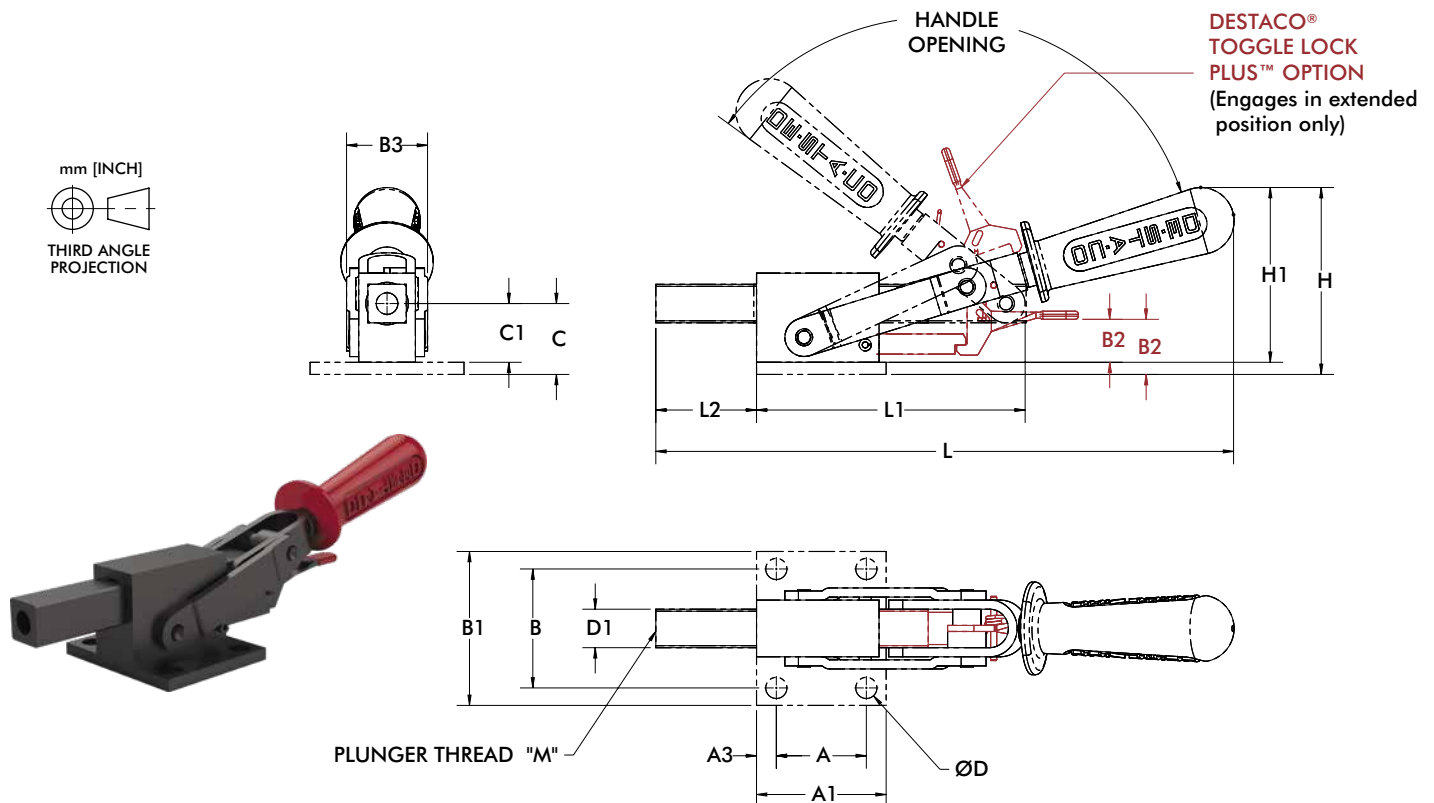

Model	A	A1	A3	B	B1	B2	B3	C	C1	D	D1
5150	44.5	64	9.8	58.7	76			35	-	10.5	
5150-M	[1.75]	[2.52]	[0.38]	[2.31]	[2.99]			[1.57]	-	[0.41]	
5150-B	-	-	-	-	-			-	29	-	
5150-MB	-	-	-	-	-		40	-	[1.14]	-	19
5150-R	44.5	64	9.8	58.7	76	27.2	[1.57]	35	-	10.5	[0.75]
5150-MR	[1.75]	[2.52]	[0.38]	[2.31]	[2.99]	[1.07]		[1.57]	-	[0.41]	
5150-BR	-	-	-	-	-	21.2		-	29	-	
5150-MBR	-	-	-	-	-	[0.84]		-	[1.14]	-	

Model	H	H1	L	L1	L2	M
5150	92.3	-				1/2-13
5150-M	[3.63]	-				M12
5150-B	-	86.3				1/2-13
5150-MB	-	[3.40]	285.3	72.6	49.7	M12
5150-R	92.3	-	[11.23]	[2.86]	[1.96]	1/2-13
5150-MR	[3.63]	-				M12
5150-BR ⓘ	-	86.3				1/2-13
5150-MBR ⓘ	-	[3.40]				M12

ⓘ This item is available upon request

# 602, 604, 624 SERIES

## Straight Line Action Clamps | Product Overview

### Features:

- Versatile and compact straight line action clamps
- Threaded body for through hole mounting
- -SS models are stainless steel
- DESTACO® Toggle Lock Plus™ versions available (604, 624 only)

### Applications:

- Assembly
- Checking fixtures
- Welding fixtures
- Tensioning devices

### Also Available:

See page MC-ACC-1 for accessories

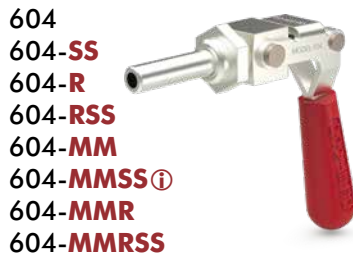

## Technical Information | Holding Capacities | Dimensions

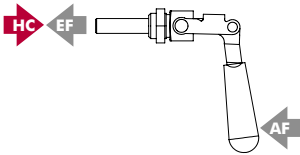

Model	Max. Holding Capacity	Weight	EF:AF (pushing/pulling)	Plunger Travel	Plunger Thread	Spindle (Recommended)	Mounting Nut (Supplied)		
602					1/4-20	205203	602105		
602-SS	[200 lbf]	[0.12 lb]	31:1/28:1	[0.75] 19	M6	202943	602905		
602-MM	900 N	0,05 kg				205203-M	602105-M		
602-MMSS						202943-M	602905-M		
604	[300 lbf]							207203	606104
604-R	1330 N		45:1/26:1	[1.50] 38	5/16-18		606904		
604-SS	[400 lbf]	[0.44 lb] 0,20 kg				M8			
604-RSS	1780 N						207943	606104-M	
604-MM	[300 lbf]								
604-MMR	1330 N								
604-MMSS ⓘ	[400 lbf]							207943-M (included)	606904-M
604-MMRSS	1780 N								
624					3/8-16	210203	624105		
624-R			49:1/21:1	[2.63] 66	M10				
624-SS									
624-RSS	[700 lbf]	[1.63 lb]					237943 (included)	624905	
624-MM	3110 N	0,74 kg							
624-MMR									
624-MMRSS								210203-M	624105-M

ⓘ This item is available upon request HC = Holding Capacity, EF = Exerting Force, AF = Applied Force

# 602 SERIES

Straight Line Action Clamps | Dimensions | -SS/-MM/-MMSS

602  
602-SS  
602-MM  
602-MMSS

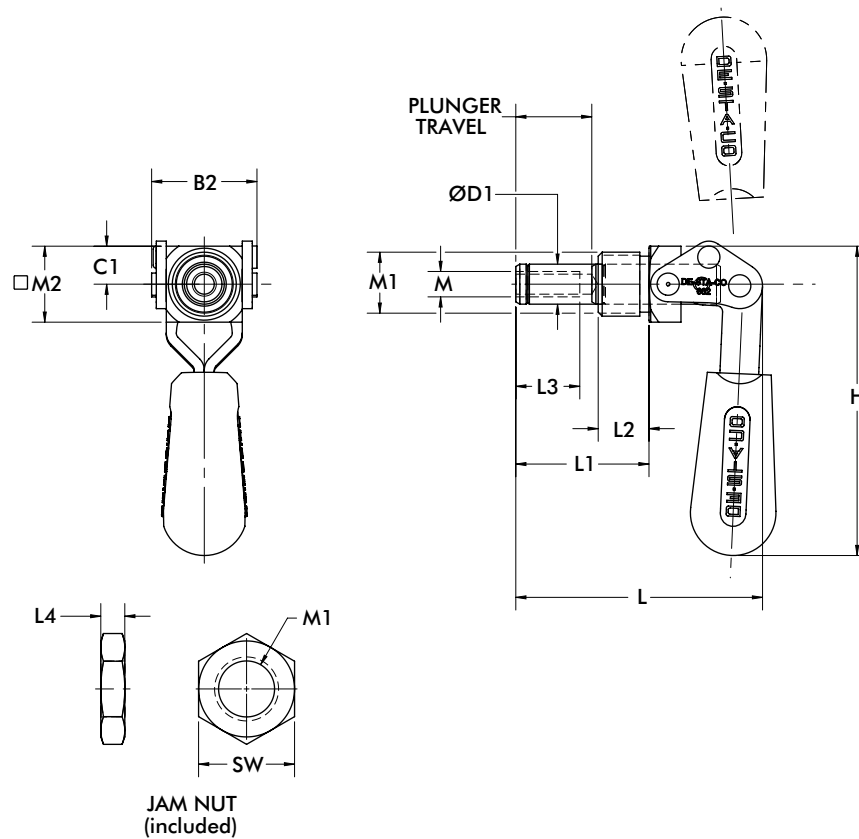

mm [INCH]  
THIRD ANGLE PROJECTION

Model no.	M	M1	SW
602	1/4-20	5/8-18	[0.88] 22,2
602-SS			
602-MM	M6	M16x1.5	[0.87] 22
602-MMSS			

# 604 SERIES

Straight Line Action Clamps | Dimensions | -SS/-MM/-MMSS/-R/-RSS/-MMR/-MMRSS

604  
604-SS  
604-MM  
604-MMSS ①



604-R  
604-RSS  
604-MMR  
604-MMRSS

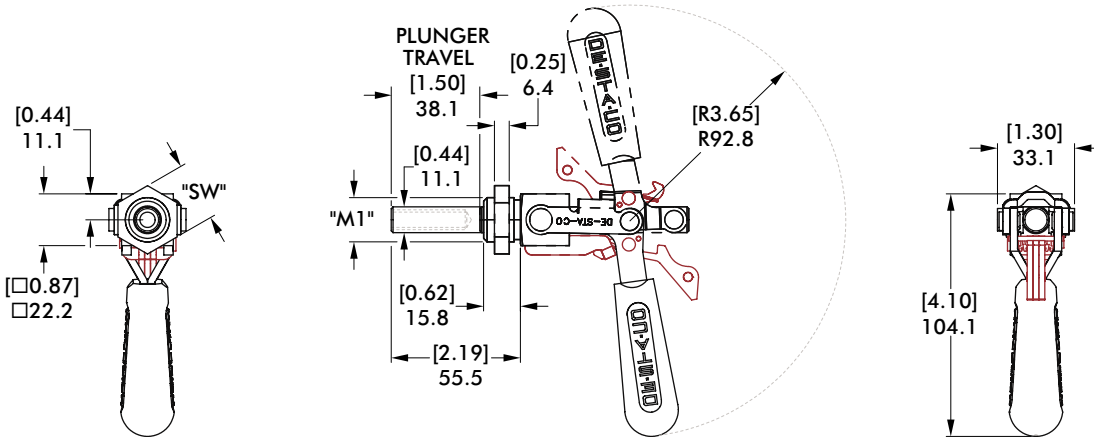
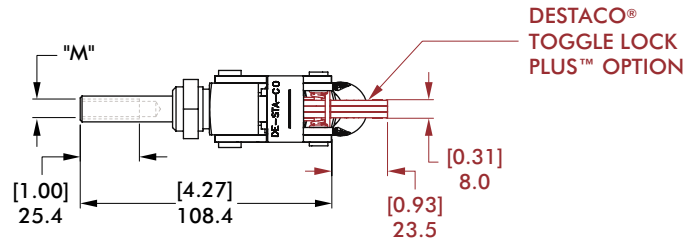

Model no.	M	M1	SW
604			
604-SS	5/16-18	3/4-16	[1.00] 25,4
604-R			
604-RSS			
604-MM			
604-MMSS	M8	M20x1.5	[1.18] 30
604-MMR			
604-MMRSS			

# 624 SERIES

## Straight Line Action Clamps | Dimensions | -SS/-MM/-R/-RSS/-MMR/-MMRSS

624  
624-SS  
624-MM



624-R  
624-RSS  
624-MMR  
624-MMRSS



DESTACO®  
TOGGLE LOCK  
PLUS™ OPTION

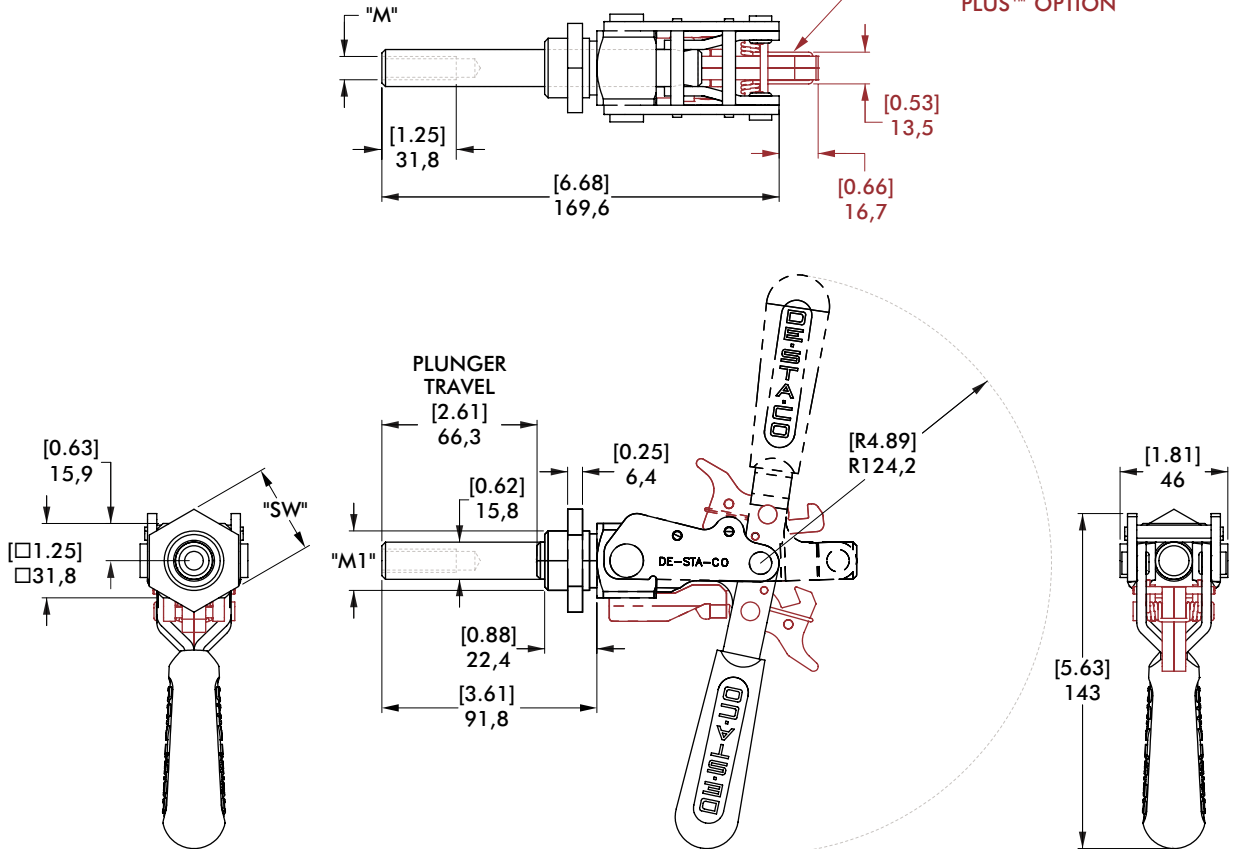

Model no.	M	M1	SW
624			
624-SS	3/8-16	1-14	[1.50] 38,1
624-R			
624-RSS			
624-MM			
624-MMR	M10	M27x2	[1.61] 41
624-MMRSS			

# 6004 SERIES

## Straight Line Action Clamps | Product Overview

### Features:

- Similar in size to Model 604, with a solid body
- 50% more holding capacity than 604
- May be mounted through a hole or in a tapped hole.
- Locks over center in the extended and retracted position

### Applications:

- Assembly
- Checking fixtures
- Welding fixtures
- Tensioning devices

### Also Available:

See page MC-ACC-1 for accessories

Covered under one or more U.S./International Patents

6004  
6004-MM



6004-R  
6004-MMR  
with  
DESTACO®  
Toggle Lock  
Plus™



## Technical Information | Holding Capacities | Dimensions

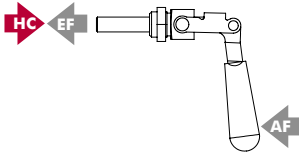

Model	Max. Holding Capacity	Weight	EF:AF (pushing)	Plunger Travel (M)	Plunger Thread (M)	Spindle (Recommended)	Mounting Nut (Supplied)
6004	[450 lbf] 2000 N	[0.81 lb] 0,37 kg	14.4:1	38 [1.50]	5/16-18	207203	606104
6004-MM		[0.89 lb] 0,40 kg			M8	207203-M	606104-M
6004-R	[450 lbf] 2000 N	[0.81 lb] 0,37 kg	14.4:1	38 [1.50]	5/16-18	207203	606104
6004-MMR		[0.89 lb] 0,40 kg			M8	207203-M	606104-M

HC = Holding Capacity, EF = Exerting Force, AF = Applied Force

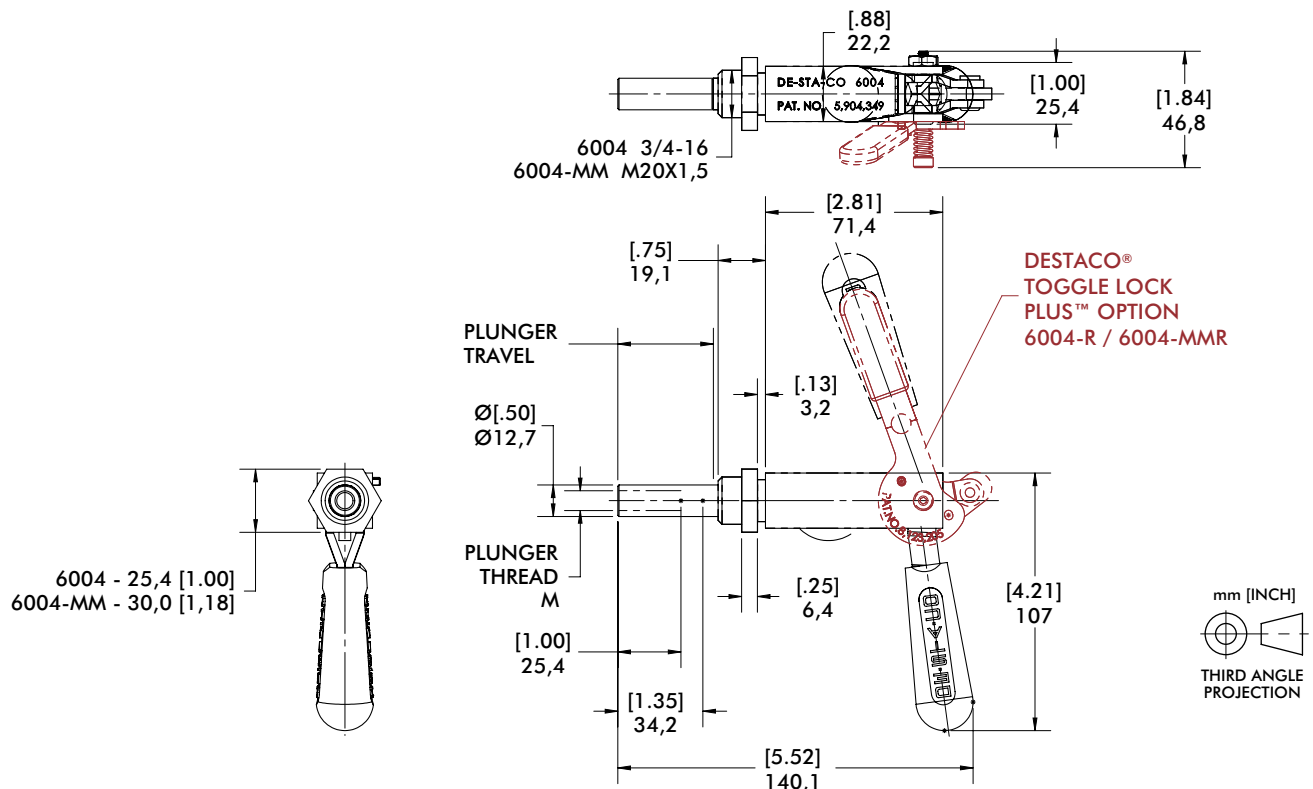



# 602, 604, 624, 6004 SERIES

Straight Line Action Clamps | Mounting Plates

## Features:

- Mounting accessories for Threaded Body Straight Line Action Clamps

602106-M



604106,  
604106-M



624106-M

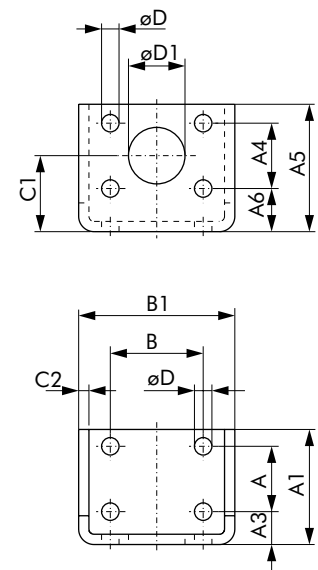
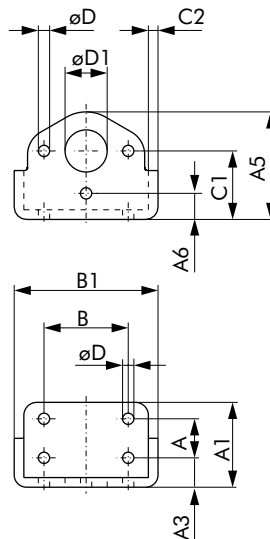
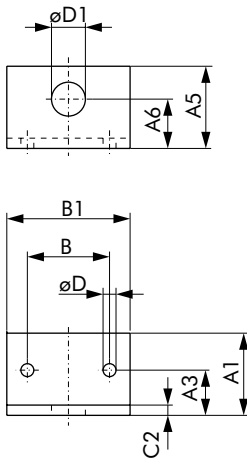

Item Number	For Use With	A	A1	A3	A4	A5	A6	B	B1	C1	C2	D	D1
602106-M	602 602-MM	--	[1.57] 40	[0.87] 22	--	[1.57] 40	[0.94] 24	[1.57] 40	[2.36] 60	--	[0.20] 5	[0.25] 6,3	[0.65] 16,5
604106	604 6004	[0.75] 19,1	[1.60] 40,6	[0.55] 14	--	[2.05] 52,1	[0.50] 12,7	[1.62] 41,1	[2.80] 71,1	[1.30] 33	[0.19] 4,7	[0.22] 5,6	[0.75] 19,1
604106-M	604-MM 6004-MM												[0.81] 20,5
624106-M	624 624-MM	[1.25] 31,8	[2.20] 56	[0.63] 16	[1.25] 31,8	[2.44] 62	[0.83] 21	[1.78] 45,2	[2.99] 76	[1.46] 37	[0.20] 5	[0.33] 8,5	[1.08] 27,5

# 614 SERIES

## Straight Line Action Clamps | Product Overview

### Features:

- Single hole threaded mount or side mount
- Precision hardened and ground plunger is designed for anti-rotation under torsional loads
- Locks in the extended or retracted position, internal locking in the push direction

### Applications:

- Assembly
- Checking fixtures
- Locaters and positioners

### Also Available:

See page MC-ACC-1 for accessories

614-M



## Technical Information | Holding Capacities | Dimensions

Model	Max. Holding Capacity	Weight	Plunger Travel	Plunger Thread	Mounting Nut (Supplied)
614-M	[1125 lbf] 5000 N	[1.81 lb] 0,82 kg	[1.26] 32	M8	614-1-10

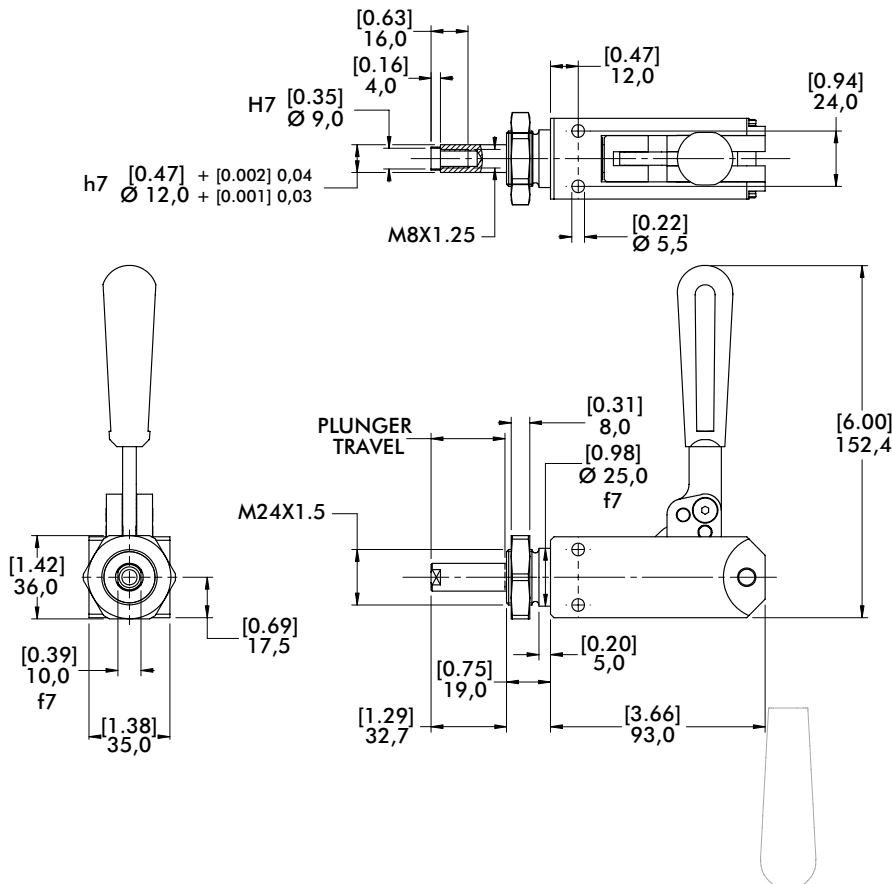



# 670, 675, 690, 695 SERIES

## Straight Line Action Clamps | Product Overview

### Features:

- Precision clamping for high production
- Adjustable collet-type bushing minimizes radial plunger movement
- Plunger has a flat surface for anti rotation
- Pre-load nut and hold open device included

### Applications:

- Assembly
- Welding

670-1MBPLS



675-1MBPLS



690-1MBPLS



695-1MBPLS ⓘ



## Series 670, 675, 690, 695 Technical Information | Holding Capacities

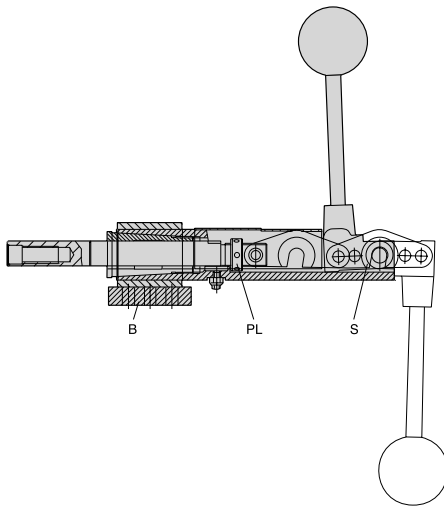

Model	Max. Holding Capacity	Weight	Plunger Travel	Plunger Thread
670-1MBPLS	[2400 lbf] 10680 N	[4.2 lb] 1,91 kg	[2.25] 57,2	M12
675-1MBPLS		[4.0 lb] 1,81 kg	[1.10] 28	
690-1MBPLS	[5000 lbf] 22240 N	[8.2 lb] 3,72 kg	[3.00] 76,2	M16
695-1MBPLS ⓘ		[7.2 lb] 3,27 kg	[1.50] 38,1	

ⓘ This item is available upon request

The unique feature of these clamps is the collet-type bushing that can be adjusted to eliminate plunger end movement after long repeated use. The plunger also has a flat which prevents lateral movement and allows offset piloting and holding. The plunger is drilled and tapped for threaded spindles or custom fixturing.

The adjustable pre-load nut (PL) can be used to lock the clamp against itself when not under pressure and therefore prevent opening when mounted vertically. The spring hold-open device (S) prevents the clamp from accidentally closing.

The mounting base (B) is supplied disassembled with the four models, to enable welding the base and the main assembly in any handle position.

Series 675 and 695 (shorter stroke) reach the over-center position only when clamping. Series 670 and 690 (longer stroke) lock in both the extended and retracted position.

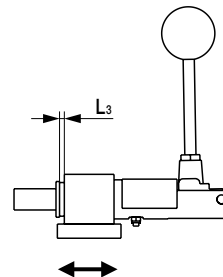

Welding range  $L_3$  axial  
0-8mm [0-0.31in.]

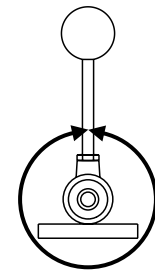

Welding range radial 360°

# 670, 675, 690, 695 SERIES

## Straight Line Action Clamps | Dimensions

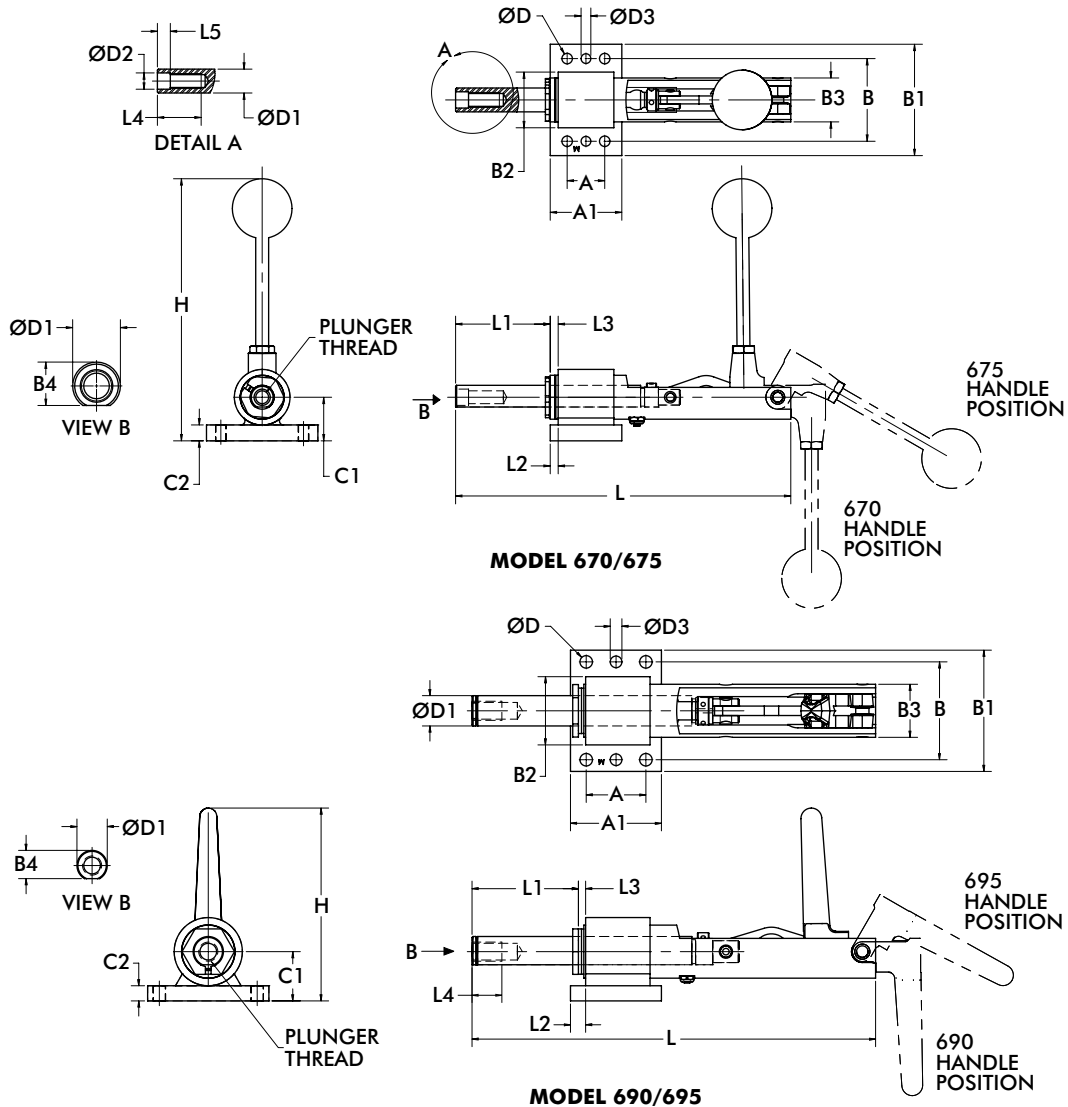

Model	A	A1	B	B1	B2	B3	B4	C1	C2	D	D1	D2H7	D3
670-1MBPLS	[1.18]	[2.24]	[2.60]	[3.50]	[1.75]	[1.38]	[0.68]	[1.37]	[0.50]	[0.33]	[0.75]	[0.51]	[0.31]
675-1MBPLS	30	57	66	89	44,5	35	17,3	34,8	12,7	8,4	19	13	7,8
690-1MBPLS	[1.97]	[3.00]	[3.23]	[4.00]	[2.25]	[1.75]	[0.93]	[1.63]	[0.50]	[0.41]	[1.00]	--	[0.39]
695-1MBPLS	50	76,2	82	101,6	57,2	44,4	23,7	41,3	12,7	10,5	25,4	--	9,8

Model	H	L	L1	L2	L3	L4	L5
670-1MBPLS	[8.11]	[10.55]	[2.97]	[0.25]	[0-0.31]	[1.38]	[0.41]
675-1MBPLS	206	[7.68]	[1.74]	6,4	0-8	35	10,3
690-1MBPLS	[6.37]	[13.31]	[3.69]	[0.50]	[0-0.31]	[0.98]	--
695-1MBPLS	162	[9.45]	[2.25]	[0.38]	0-8	25	--

# FO, FL, G SERIES

## Variable Stroke Straight Line Action Clamps | Product Overview

### FO Series

#### Type of Mounting:

- Foot mount

#### Type of Actuation:

- Hand wheel or hand lever (one-handed operation)
- Locking lever and Plunger (two-handed operation)



### FL Series

#### Type of Mounting:

- Flange mount

#### Type of Actuation:

- Locking lever or hand wheel (one-handed operation)
- Locking lever and Plunger (two-handed operation)

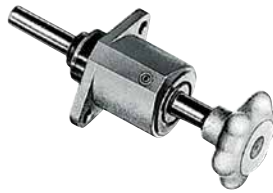

### G Series

#### Type of Mounting:







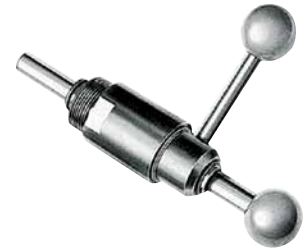

- Through hole mount

#### Type of Actuation:

- Locking lever and Plunger (two-handed operation)
- Hand wheel or hand lever (one-handed operation)



## Technical Information

		Model	Holding Capacity Max. [lbs] N	Page MC-VSC-#	Accessories	Model	Page MC-VSC-#
Flanged base		<b>FO-082-40</b>	[335] 1500	3	Plunger	<b>12/100</b>	4
		<b>FO-120</b>	[675] 3000			<b>12/200</b>	
	<b>FO-121-45</b>	[675] 3000	<b>12/300</b>				
	<b>FO-122-45</b>	[675] 3000	<b>16/100</b>				
		<b>FO-160</b>	[2020] 9000		<b>16/200</b>		
	<b>FO-161-60</b>	[2020] 9000	<b>16/300</b>				
	<b>FO-162-60</b>	[2020] 9000	<b>16/400</b>				
	<b>FO-220</b>	[4045] 18000	<b>16/500</b>				
	<b>FO-221-80</b>	[4045] 18000	<b>22/100</b>				
			<b>22/200</b>				
			<b>22/300</b>				
Front flange		<b>FL-120</b>	[675] 3000	3	Swivel thrust pad	<b>K508</b>	7
		<b>FL-121-45</b>	[675] 3000			<b>K612</b>	
		<b>FL-122-45</b>	[675] 3000		<b>K816</b>		
		<b>FL-160</b>	[2020] 9000		<b>K1222</b>		
	<b>FL-161-60</b>	[2020] 9000					
	<b>FL-162-60</b>	[2020] 9000					
Threaded mount		<b>G-082-40</b>	[335] 1500	3			
		<b>G-120</b>	[675] 3000				
		<b>G-121-45</b>	[675] 3000				
		<b>G-122-45</b>	[675] 3000				
		<b>F-160</b>	[4,040] 18000	3			

**Two-hand operation**  
(the plunger and the hand lever are operated separately)

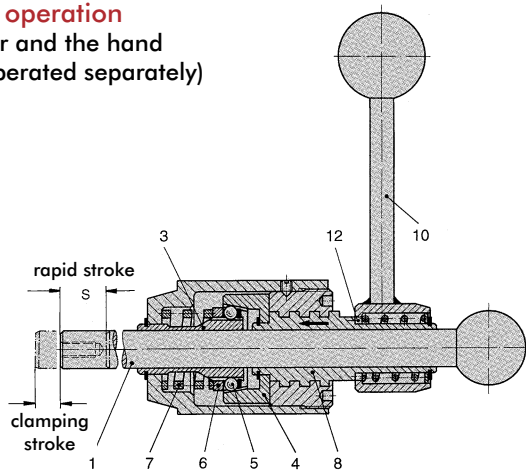

**One-hand operation**  
(the plunger and handle lever/hand wheel are operated simultaneously)

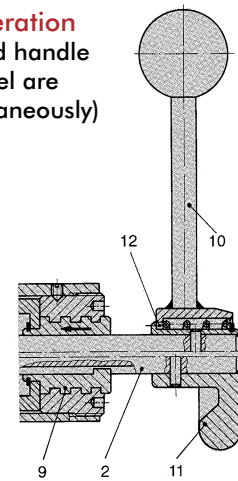

DESTACO's variable stroke Straight Line clamps are used in applications where workpiece thicknesses and workpiece tolerances vary. These clamps are suitable for clamping between ribs and hollow spaces difficult to reach.

Compact design and different types of operation allow for application of the Straight Line clamps in fixtures for mass production as well as for single part production.

### Mounting types

- Foot base (FO Series)
- Flange mount (FL Series)
- Through hole mount (G Series)

### Type of operation

- Two hand operation
- The hand lever (10) and the plunger (1) are separate. The hand lever is connected to the clamping mechanism. The plunger can be removed from the clamp
- One-hand operation
- The hand lever (10) or the hand wheel (11) and the plunger (2) are linked. The plunger is retained within the clamp.

### Clamping operation

The plunger (1) or (2) which is guided within the clamp body contacts the workpiece. By rotating the hand lever (10) or the hand wheel (11) clock-wise the clamping stroke, S1 is engaged and the plunger is tightly gripped by the slotted clamping sleeve (3).

### Operating principle

The hand lever's (10) clock-wise rotation causes the threaded sleeve (8) and the conical sleeve (4) to which it is connected to move in the direction of the arrow shown in the drawing. The conical sleeve produces a force-locking connection between the slotted clamping sleeve (3) and the plunger by means of the ball bearings (5) located at the clamping sleeve's perimeter.

Due to the force-locking connection, the plunger rotates and produces the clamping stroke S1. The plungers rotation may be compensated for by means of a swivel hold-down piece.

The clamping strokes S1 specified in this catalog were measured with no opposing forces present while measurements were taken. When clamping this product against a workpiece, the clamping stroke S1 is reduced by the force-locking connection between the plunger and the workpiece. The straight-action clamp is unlocked by turning the hand lever or the hand wheel counter-clockwise. This method is used for both the one-hand and the two-hand operation types. This counter-clockwise rotation makes the conical sleeve (4) and the threaded sleeve (8) or (9) move backward. The pressure spring (7) pushes back the relieved ball bearings (5) via the pressure ring (6).

The force-locking connection between the slotted clamping sleeve and the plunger can be moved freely again. Straight Line clamps which are two-hand operated can also be applied to pull actions when the plunger is inserted in the clamp's housing in the opposite direction. On the one hand operated clamp, the rotation inducing the clamping stroke S1 is directly transmitted from the plunger (2) or the hand wheel to the threaded sleeve (9) via a groove/spring connection. The clamping and unclamping operations are executed in the same way as described before.

### Handling

To change the position of the handle while in the clamped or the unclamped position, pull the hand lever off its spline (12) and set it in the desired position.

### Important

The holding forces specified in the catalog refer to the maximum load exerted on the clamp by counter-forces. For details concerning the clamping force FS exerted on the workpiece by the clamp and depending on the operation force FB (manual force), please see the chart on the next page.

The clamping force is proportional to the operation force. The achieved clamping force must not exceed the maximum holding force.

As the Straight Line clamps, with the exception of the F-160 model, are designed only for axial load, we recommend to use an additional radial support for the plunger in the event of side load.

# FO, FL, G SERIES

## Variable Stroke Straight Line Action Clamps | Technical Information

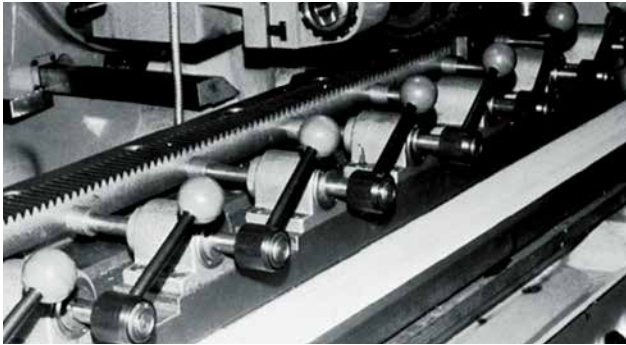

Model FO-161/60 on a milling machine

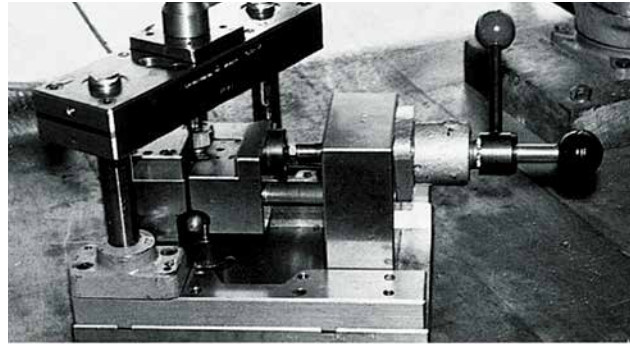

Model FL-160 with plunger 16/100 on a punching fixture

### Different Designs



#### FO Series

**Mounting type:** flange base foot mount  
**Operating method:** one-hand or two-hand operation

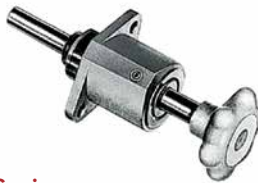











#### FL Series

**Mounting type:** front flange mount  
**Operating method:** one-hand or two-hand operation



#### G Series

**Mounting type:** through hole mount  
**Operating method:** one-hand or two-hand operation

Mounting type	Operating method			Model	Max. holding capacity [lbs.] N	Clamping force F <sub>s</sub> with an operating force F <sub>B</sub>		Rapid stroke S [mm]	Max. clamping stroke S1 [mm]	Weight	
	Two-hand operation Plunger and hand lever	One-hand operation Hand lever	One-hand operation Hand wheel			FB [lbs.] N	FS [lbs.] N			[lbs]	Kg
Foot mount 		<input checked="" type="checkbox"/>	<input type="checkbox"/>	<input checked="" type="checkbox"/>	FO-082-40	[335] 1500	[22] 100	[100] 450	40	2,5	[0.72] 0,325
		<input checked="" type="checkbox"/>	<input type="checkbox"/>	<input type="checkbox"/>	FO-120 <sup>1)</sup>	[675] 3000		[425] 1900	100, 200, 300	3	[1.19] 0,540
		<input type="checkbox"/>	<input checked="" type="checkbox"/>	<input type="checkbox"/>	FO-121-45	[675] 3000		[425] 1900	45	3	[1.47] 0,665
		<input checked="" type="checkbox"/>	<input type="checkbox"/>	<input type="checkbox"/>	FO-122-45	[675] 3000		[100] 450	40	3	[1.34] 0,610
		<input checked="" type="checkbox"/>	<input type="checkbox"/>	<input type="checkbox"/>	FO-160 <sup>1)</sup>	[2020] 9000		[560] 2500	100, 200, 300	4	[2.73] 1,240
		<input type="checkbox"/>	<input checked="" type="checkbox"/>	<input type="checkbox"/>	FO-161-60	[2020] 9000		[560] 2500	60	4	[3.40] 1,540
Flange mount 		<input type="checkbox"/>	<input type="checkbox"/>	<input checked="" type="checkbox"/>	FO-162-60	[2020] 9000	[190] 850	60	4	[3.15] 1,430	
		<input checked="" type="checkbox"/>	<input type="checkbox"/>	<input type="checkbox"/>	FO-220 <sup>1)</sup>	[4045] 18000	[675] 3000	100, 200, 300	4	[5.85] 2,655	
		<input type="checkbox"/>	<input checked="" type="checkbox"/>	<input type="checkbox"/>	FO-221-80	[4045] 18000	[675] 3000	80	4	[7.46] 3,385	
		<input checked="" type="checkbox"/>	<input type="checkbox"/>	<input type="checkbox"/>	FL-120 <sup>1)</sup>	[675] 3000	[425] 1900	100, 200, 300	3	[1.07] 0,485	
		<input checked="" type="checkbox"/>	<input type="checkbox"/>	<input type="checkbox"/>	FL-121-45	[675] 3000	[425] 1900	45	3	[1.34] 0,610	
		<input type="checkbox"/>	<input checked="" type="checkbox"/>	<input type="checkbox"/>	FL-122-45	[675] 3000	[100] 450	40	3	[1.21] 0,550	
Through hole mount 		<input checked="" type="checkbox"/>	<input type="checkbox"/>	<input type="checkbox"/>	FL-160 <sup>1)</sup>	[2020] 9000	[560] 2500	100, 200, 300	4	[2.49] 1,130	
		<input type="checkbox"/>	<input checked="" type="checkbox"/>	<input type="checkbox"/>	FL-161-60	[2020] 9000	[560] 2500	60	4	[3.15] 1,430	
		<input type="checkbox"/>	<input type="checkbox"/>	<input checked="" type="checkbox"/>	FL-162-60	[2020] 9000	[190] 850	60	4	[2.92] 1,325	
		<input checked="" type="checkbox"/>	<input type="checkbox"/>	<input type="checkbox"/>	G-082-40	[335] 1500	[100] 450	40	2,5	[0.66] 0,300	
Through hole mount 		<input checked="" type="checkbox"/>	<input type="checkbox"/>	<input type="checkbox"/>	G-120 <sup>1)</sup>	[675] 3000	[425] 1900	100, 200, 300	3	[1.01] 0,470	
		<input type="checkbox"/>	<input checked="" type="checkbox"/>	<input type="checkbox"/>	G-121-45	[675] 3000	[425] 1900	45	3	[1.31] 0,595	
		<input type="checkbox"/>	<input type="checkbox"/>	<input checked="" type="checkbox"/>	G-122-45	[675] 3000	[100] 450	40	3	[1.18] 0,335	
		<input checked="" type="checkbox"/>	<input type="checkbox"/>	<input type="checkbox"/>							



Two-hand operation (the plunger and the hand lever are operated separately)

### Through hole mount

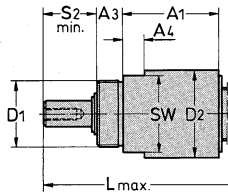

Part no. G-121/45

### Flange mount

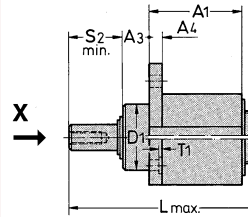

#### View "X"

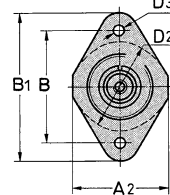

Part no. FL-120/--

#### View "X"

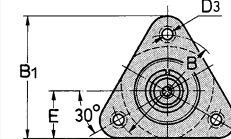

Part no. FL-160/--

### Foot mount

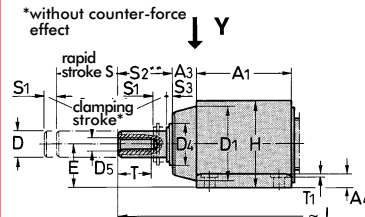

#### View "Y"

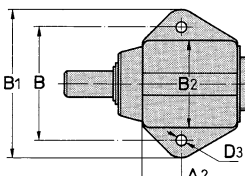

Part no. FO-120/--

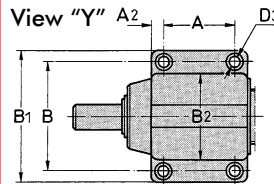

Part no. FO-160/--  
FO-220/--

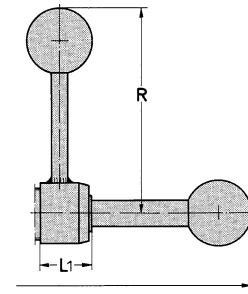

### Accessories

(order separately)

### Plunger

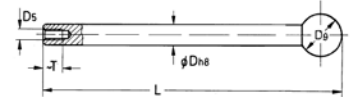

Part no. Ø length	For rapid stroke S	Weight ~ [lbs.] kg	For clamps
12/100	100	[0.30] 0,135	FO-120
12/200	200	[0.62] 0,280	FL-120
12/300	300	[0.82] 0,370	G-120
16/100	100	[0.88] 0,400	FO-160
16/200	200	[1.10] 0,500	FL-160
16/300*	300	[1.54] 0,700	
22/100	100	[2.20] 1,000	
22/200	200	[2.40] 1,090	FO-220
22/300	300	[3.06] 1,390	

\*400 and 500 mm lengths available upon request.

**Important**  
The Straight Line clamps are designed only for **axial load**. In case of side load, we recommend an additional radial support of the plunger.

Mounting type		Part no. without plunger	Available rapid strokes S (order plunger separately)	A	A1	A2	A3	A4	A8	B	B1	B2	Dh8	D1	D2	D3	D4
Foot mount		FO-120	100, 200, 300	-	44	19	12	6,3	8,5	52	68	40	12	35	-	6,5	20
		FO-160	100, 200, 300	40	62	11	12	12	10	70	90	52	16	46	-	9	25
		FO-220	100, 200, 300	50	75	13	20	15	12	90	115	69	22	60	-	11	36
Flange mount		FL-120	100, 200, 300	-	44	44	12	6	8,5	52	68	-	12	30f7	40	6,5	20
		FL-160	100, 200, 300	-	60	-	14	14	10	68	73	-	16	40f7	52	9	25
Through hole mount		G-120	100, 200, 300	-	44	-	12	10	8.5	-	-	-	12	M30 x1,5	40	-	20

Mounting type	Part no. without plunger	D5	D6	E	E1	H	~ L L with rapid strokes:			L1	R	S2	S3	SW	SW1	T	T1	T3	
							100	200	300										
Foot mount		FO-120	M6	30	20	12,5	42	226	326	426	24	95	2,5	2,5	-	11	12	-	10
		FO-160	M8	35	30	14,8	58	253	353	453	33	130	3	3	-	13	15	1	14
		FO-220	M12	40	35	19,5	71	287	387	487	35	197	3	3	-	17	25	1	18
Flange mount		FL-120	M6	30	-	12,5	-	226	326	426	24	95	2,5	2,5	-	11	12	-	10
		FL-160	M8	35	28	14,8	-	253	353	453	33	130	3	3	-	13	15	1	14
Through hole mount		G-120	M6	30	-	12,5	-	226	326	426	24	95	2,5	2,5	35	11	12	-	12

# FO, FL, G SERIES

## Variable Stroke Straight Line Action Clamps | Technical Information | Dimensions

One-hand operation (the plunger and the hand wheel are operated simultaneously)

### Through hole mount

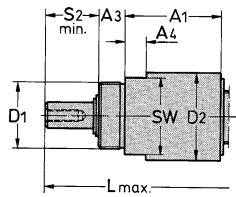

Part no. G-082/40  
G-122/45

### Flange mount

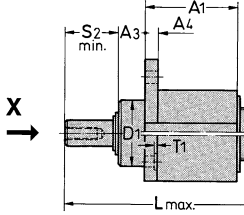

View "X"

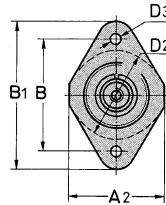

Part no. FL-122/45

View "X"

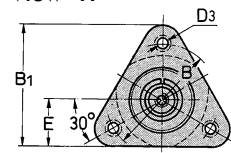

Part no. FL-162/60

### Foot mount

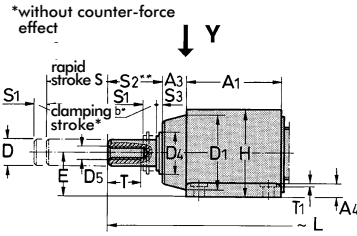

View "Y"

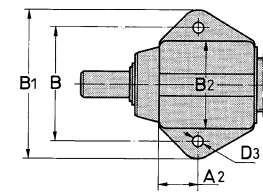

Part no. FO-082/40  
FO-122/45

View "Y"

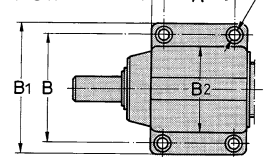

Part no. FO-162/60

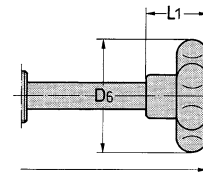

### Important

The Straight Line clamps are designed only for **axial load**. In case of side load, we recommend an additional radial support of the plunger.

Mounting type	Part no. with plunger	A	A <sub>1</sub>	A <sub>2</sub>	A <sub>3</sub>	A <sub>4</sub>	A <sub>5</sub>	B	B <sub>1</sub>	B <sub>2</sub>	D <sub>h8</sub>	D <sub>1</sub>	D <sub>2</sub>	D <sub>3</sub>	D <sub>4</sub>
	FO-082-40	-	37	15,3	10	5	6	44	56	35	8	30	-	4,5	16
	FO-122-45	-	44	19	12	6,3	8,5	52	68	40	12	35	-	6,5	20
	FO-162-60	40	62	11	12	12	10	70	90	52	16	46	-	9	25
	FL-122-45	-	44	44	12	6	85	52	68	-	12	30f7	40	6,5	20
	FL-162-60	-	60	-	14	14	10	68	73	-	16	40f7	52	9	25
	G-082-40	-	37	-	10	8	6	-	-	-	8	M24x1,5	35	-	16
	G-122-45	-	44	-	12	10	8,5	-	-	-	12	M30x1,5	40	-	20

Mounting type	Part no. with plunger	D <sub>5</sub>	D <sub>6</sub>	E	E <sub>1</sub>	H	L	L <sub>1</sub>	S <sub>2</sub>	S <sub>3</sub>	SW	SW <sub>1</sub>	T	T <sub>1</sub>	T <sub>3</sub>
	FO-082-40	M5	40	18	9,2	36	128	26	9	2,5	-	8	8	-	8
	FO-122-45	M6	75	20	12,5	42	153	27	15	2,5	-	11	12	-	10
	FO-162-60	M8	75	30	14,8	58	196	35	18	3	-	13	15	1	14
	FL-122-45	M6	52	-	12,5	-	153	27	15	2,5	-	11	12	-	10
	FL-162-60	M8	75	28	14,8	-	196	35	18	3	-	13	15	1	14
	G-082-40	M5	40	-	9,2	-	128	26	9	2,5	30	8	12	-	8
	G-122-45	M6	52	-	12,5	-	153	27	15	2,5	35	11	12	-	10

One-hand operation (the plunger and the hand lever are operated simultaneously)

### Through hole mount

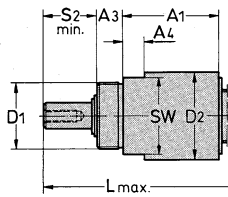

Part no. G-121/45

### Flange mount

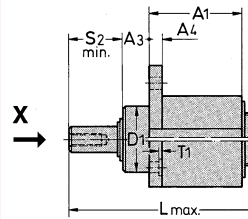

#### View "X"

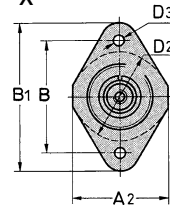

Part no. FL-121/45

#### View "X"

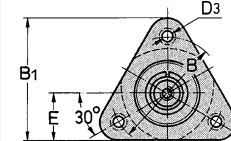

Part no. FL-161/60

### Foot mount

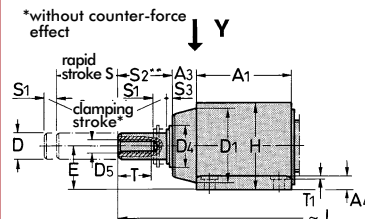

#### View "Y"

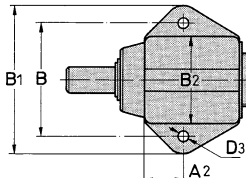

Part no. FO-121/45

#### View "Y"

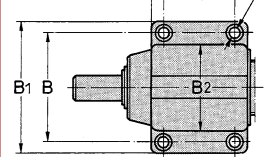

Part no. FO-161/60  
FO-221/80

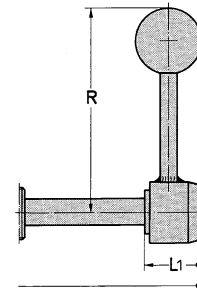

### Important

The Straight Line clamps are designed only for **axial load**. In case of side load, we recommend an additional radial support of the plunger.

Mounting type	Part no. with plunger	A	A <sub>1</sub>	A <sub>2</sub>	A <sub>3</sub>	A <sub>4</sub>	A <sub>5</sub>	B	B <sub>1</sub>	B <sub>2</sub>	D <sub>h8</sub>	D <sub>1</sub>	D <sub>2</sub>	D <sub>3</sub>	D <sub>4</sub>
Foot mount	FO-121-45	-	44	19	12	6,3	8,5	52	68	40	12	35	-	6,5	20
	FO-161-60	40	62	11	12	12	10	70	90	52	16	46	-	9	25
	FO-221-80	50	75	13	20	15	12	90	115	69	22	60	-	11	36
Flange mount	FL-121-45	-	44	44	12	6	8,5	52	68	-	12	30f7	40	6,5	20
	FL-161-60	-	60	-	14	14	10	68	73	-	16	40f7	52	9	25
Through hole mount	G-121-45	-	44	-	12	10	8,5	-	-	-	12	M30x1,5	40	-	20

Mounting type	Part no. with plunger	D <sub>5</sub>	E	E <sub>1</sub>	H	L	L <sub>1</sub>	R	S <sub>2</sub>	S <sub>3</sub>	SW	SW <sub>1</sub>	T	T <sub>1</sub>	T <sub>3</sub>
Foot mount	FO-121-45	M6	20	12,5	42	153	27	95	15	2,5	-	11	12	-	10
	FO-161-60	M8	30	14,8	58	196	35	130	18	3	-	13	15	1	14
	FO-221-80	M12	35	19,5	71	245	40	197	20	3	-	17	25	1	18
Flange mount	FL-121-45	M6	-	12,5	-	153	27	95	15	2,5	-	11	12	-	10
	FL-161-60	M8	28	14,8	-	196	35	130	18	3	-	13	15	1	14
Through hole mount	G-121-45	M6	-	12,5	-	153	27	95	15	2,5	35	11	12	-	10

# F-160 SERIES

## Variable Stroke Straight Line Action Clamps | Technical Information | Dimensions



### Technical features:

- High holding capacity of [4040 lbf] 18000N lbs.
- High side load capacity
- Plunger guide
- Wiper ring avoiding contamination of clamping mechanism
- Block style base provides for variable mounting
- Low weight due to the aluminium housing
- 50 mm horizontal and vertical hole pattern

### Accessories (order separately)

#### Plunger

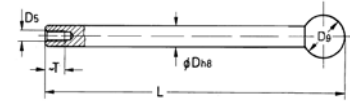

Part no.	For rapid stroke S	D <sub>H8</sub>	D <sub>5</sub>	D <sub>9</sub>	L ~	T ~	Weight ~ [lbs.] kg
16/100	100	16	M8	35	253	15	[0.90] 0,4
16/200	200	16	M8	35	353	15	[1.10] 0,5
16/300*	300	16	M8	35	453	15	[1.54] 0,7

\*400 and 500 mm strokes available on request

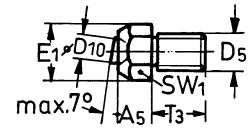

#### Swivel thrust pad

Part no.	Use with plunger diameter	A <sub>5</sub>	D <sub>5</sub>	D <sub>10</sub>	E <sub>1</sub>	T <sub>3</sub>	SW <sub>1</sub>
K-508	8	6	M5	5	9,2	8	8
K-612	12	8,5	M6	6	12,5	10	11
K-816	16	10	M8	8	14,8	14	13
K-1222	22	12	M12	9,5	19,5	18	17

Allowable side load F<sub>s</sub> depending on the stroke length L<sub>H</sub>

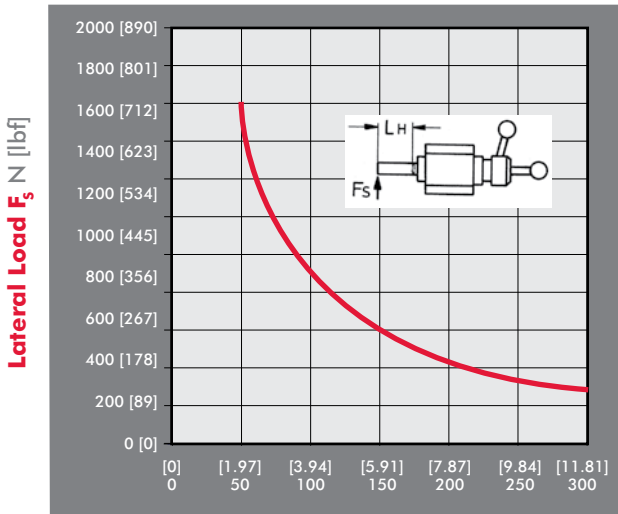

Stroke Length L<sub>H</sub> mm [in]

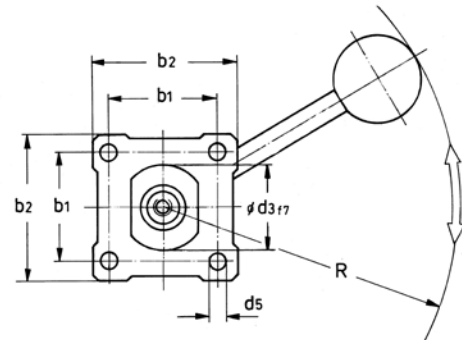
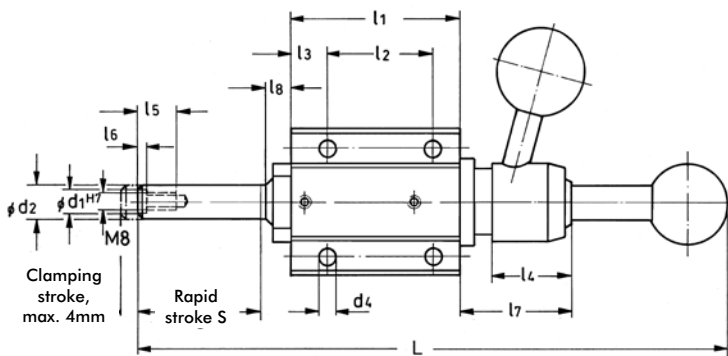

Part no. without plunger	Max. holding cap. [lbs] N	F <sub>s</sub> * [lbs] N	~L																Weight ~ [lbs.] kg			
			b <sub>1</sub>	b <sub>2</sub>	For rapid strokes:			11	12	13	14	15	16	17	18	d <sub>1</sub> <sup>H7</sup>	d <sub>2</sub> <sup>H8</sup>	d <sub>3</sub>		d <sub>4</sub>	d <sub>5</sub>	R
F-160	[4040] 18000N	[1124] 5000N	50	68	250	350	451	80	50	18	35	20	2	50	12	10	16	40	8,3	8,5	165	[3.30] 1,5

\*F<sub>s</sub>=exerting force at an operating force of [22lbf] 100N.



# 3031, 3051 SERIES

## Pull Action Latch Clamps | Product Overview

### Features:

- Safe, single handed operation
- Innovative controlled motion
- Secure toggle locking action
- Simple set-up and adjustment
- Clamp hook/arm moves and stays safely out of the way
- Stainless steel version available as **-SS** models

### Applications:

- Molding
- Closures for doors, lids, covers
- Assembly
- Checking fixtures

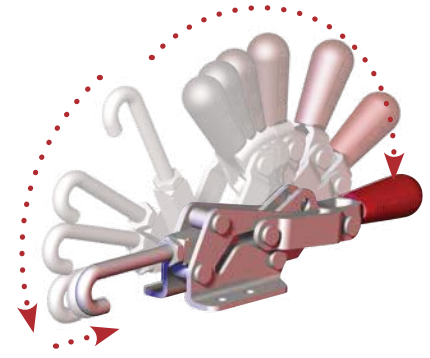

3031 ⓘ  
3031-SS



3031-R ⓘ  
3031-RSS ⓘ  
with DESTACO®  
Toggle Lock  
Plus™



3051  
3051-SS



3051-R  
3051-RSS  
with DESTACO®  
Toggle Lock  
Plus™



## Technical Information | Holding Capacities | Dimensions

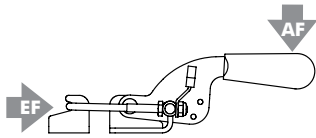

Model	Max. Holding Capacity	Weight	EF:AF	Drawing Movement	Replacement Hook Assembly	Hook Adj. Range
3031 ⓘ	900N [200lbf]	0,30kg [0.65lb]	12:1	12,7 [0.50]	3031208	10 [0.39]
3031-R ⓘ					3031808	
3031-SS						
3031-RSS ⓘ						
3051	6700N [1500lbf]	0,50kg [1.0lb]		19,1 [0.75]	3051208	14 [0.55]
3051-R					3051808	
3051-SS						
3051-RSS						

ⓘ Coming Soon

# 3031, 3051 SERIES

## Pull Action Latch Clamps | Product Overview

3031 ⓘ  
3031-SS



3031-R ⓘ  
3031-RSS ⓘ



3051  
3031-SS



3051-R  
3051-RSS

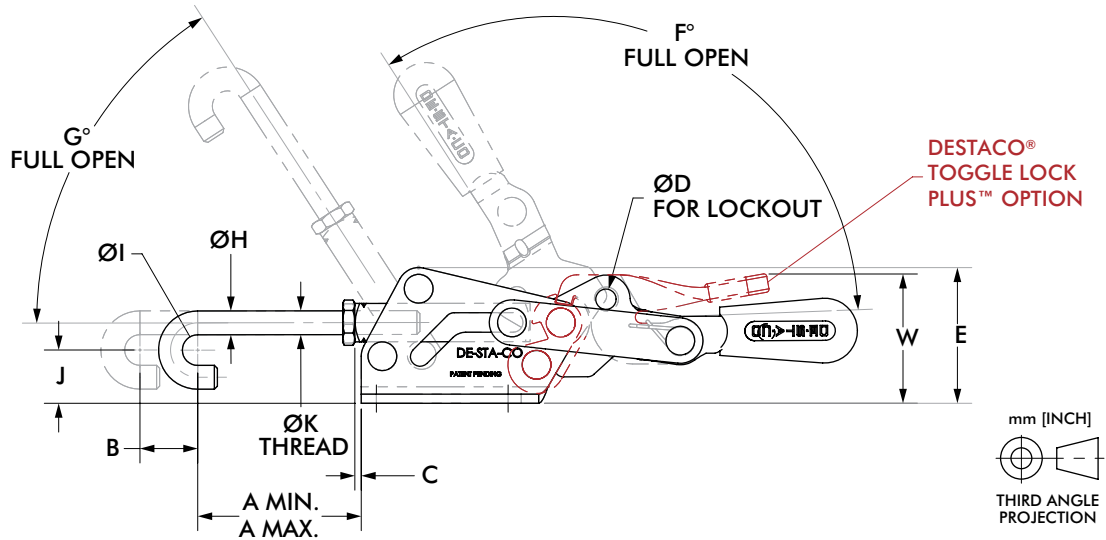
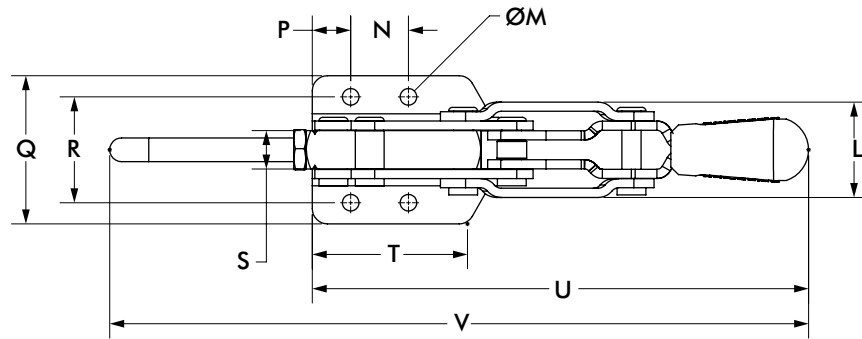

mm [INCH]  
THIRD ANGLE PROJECTION

Model	A min.	A max	B	C	D	E	F	G	H	I	J	K
3031 ⓘ												
3031-SS	[1.62]	[2.02]	[.50]	[.16]	[.19]	[1.35]	123°	50°	[.17]	[.32]	[.48]	M5x0.8
3031-R ⓘ	41,25	51,25	12,5	4,1	Ø4,7	34,3			Ø4,4	Ø8,1	12,1	
3031-RSS ⓘ												
3051												
3051-SS	[1.99]	[2.50]	[.75]	[.08]	[.27]	[1.77]	123°	57°	[.31]	[.39]	[.69]	M8x1.25
3051-R	50,6	63,6	19,1	2,1	Ø6,7	44,9			Ø8,0	Ø10	17,6	
3051-RSS												

Model	L	M	N	P	Q	R	S	T	U	V	W
3031 ⓘ											-
3031-SS	[1.12]	[.22]	[.75]	[.38]	[1.69]	[1.22]	[.38]	[1.65]	[5.71]	[8.06]	-
3031-R ⓘ	28,4	Ø5,5	19,1	9,5	43	31,1	9,5	42	145,1	204,8	[1,77]
3031-RSS ⓘ											44.8
3051											-
3051-SS	[1.24]	[.22]	[.75]	[.50]	[1.93]	[1.38]	[.50]	[2.03]	[6.47]	[8.98]	-
3051-R	31,4	Ø5,5	19,1	12,7	49	35	12,7	51,5	164,4	228	[1.68]
3051-RSS											42,7

ⓘ Coming Soon

# 330, 351, 371, 381 SERIES

## Pull Action Latch Clamps | Product Overview

### Features:

- J-hook style latch clamps are supplied with threaded J-hooks for easy adjustment
- Supplied with patented thumb control lever for one handed operation
- DESTACO® Toggle Lock Plus™ versions available
- Stainless steel version available as **-SS** models

### Applications:

- Molding
- Closures for doors, lids, covers
- Assembly

### Also Available:

- Clamps with longer hooks available Upon Request that are 25mm, 50mm, 100mm longer than standard length
- To order clamp with longer hook, add **-M-25**, **-M-50**, or **-M-100** to the end of the model. Example: 330-**M-50**

Covered under one or more U.S./International Patents

330  
330-SS



351  
351-SS



351-B  
351-BSS  
Narrow Base



351-R  
351-RSS  
with DESTACO®  
Toggle Lock  
Plus™



371  
371-SS



371-R  
371-RSS  
with DESTACO®  
Toggle Lock  
Plus™



381  
381-SS



## Technical Information | Holding Capacities

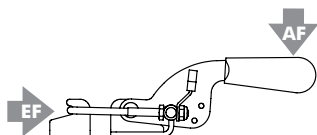

Model	Max. Holding Capacity	Weight	EF:AF	Drawing Movement	Replacement Hook Assembly	Hook Adj. Range				
330	900 N [200 lbf]	0,11kg [0.24lb]	17:1	59,7 [2.35]	330215	7.4 [0.29]				
330-SS					330915					
351	1670 N [375 lbf]	0,28kg [0.61lb]	21:1	101,6 [4.00]	351215	12.4 [0.49]				
351-SS	2000 N [450 lbf]				351915					
351-B	1670 N [375 lbf]				351215					
351-BSS					351915					
351-R					351215					
351-RSS					351915					
371	3340 N [750 lbf]				0,69kg [1.53lb]		36:1	136,7 [5.38]	371215	23.9 [0.94]
371-SS									371915	
371-R		371215								
371-RSS		371915								
381	4450 N [1000 lbf]	1,16kg [2.56lb]	37:1	155,7 [6.13]	381215	29.7 [1.17]				
381-SS					381915					

EF = Exerting Force, AF = Applied Force



# 330, 351, 371, 381 SERIES

Pull Action Latch Clamps | Dimensions | -SS/-B/-BSS

330  
330-SS



351  
351-SS



371  
371-SS



381  
381-SS

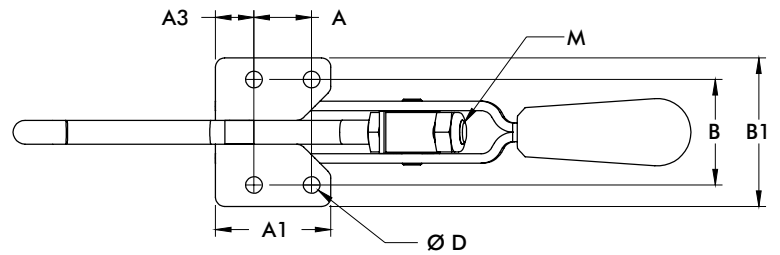
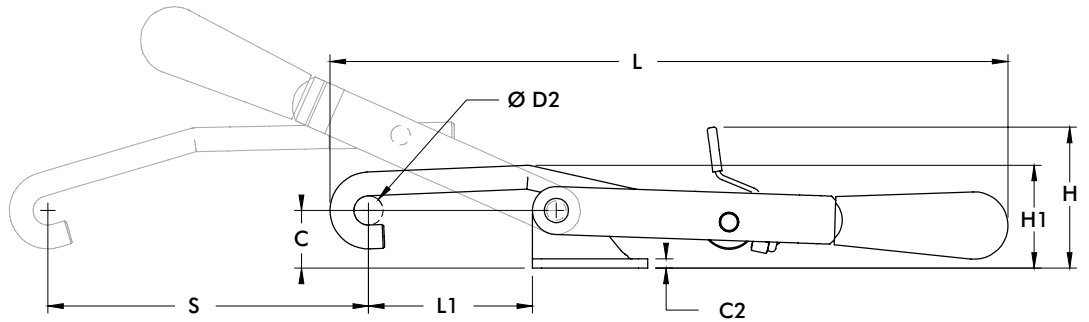

351-B  
351-BSS  
Narrow Base

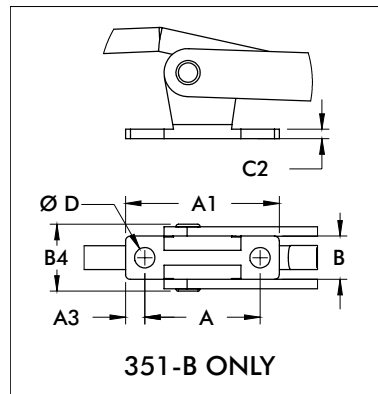
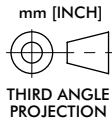

Model	A	A1	A3	B
330	[0.50]	[1.00]	[0.25]	[1.22]
330-SS	12,7	25,4	6,4	30,9
351	[0.75]	[1.50]	[0.50]	[1.37]
351-SS	19,1	38,1	12,7	34,8
351-B	[1.50]	[2.00]	[0.25]	[0.56]
351-BSS	38,1	38,1	6,4	14,3
371	[1.25]	[1.94]	[0.34]	[1.94]
371-SS	31,8	49,2	8,7	49,2
381	[1.13]	[2.13]	[0.50]	[2.37]
381-SS	28,6	54,1	12,7	60,3

Model	B1	B4	C	C2	Ø D	Ø D2	H	H1	L	L1 Max	M	S
330	[1.69]	-	[0.56]	[0.12]	[0.22]	[0.32]	[1.43]	[0.89]	[6.01]	[1.70]	M5	[2.35]
330-SS	42,9	-	14,2	3,1	5,6	8,1	36,2	22,6	152,7	43,3		59,7
351	[1.93]	-	[0.75]		[0.22]		[1.83]	[1.34]	[8.82]	[2.13]	M8	[4.00]
351-SS	49,1	-	19,1	[0.12]	5,5	[0.38]	46,6	34	224	54,2		
351-B		[0.87]	[0.86]		[0.27]		[1.94]	[1.45]		[1.63]		
351-BSS		22,1	21,8		6,7		49,3	36,8		41,4		
371	[2.63]	-	[1.42]	[0.16]	[0.34]	[0.50]	[2.58]	[2.23]	[11.89]	[2.81]	M10	[5.38]
371-SS	66,7	-	36,1	4	8,7	12,7	65,6	56,5	302	71,5		136,7
381	[3.38]	-	[1.81]	[0.19]	[0.41]	[0.62]	[2.90]	[2.71]	[13.45]	[3.13]	M12	[6.13]
381-SS	85,9	-	46	4,7	10,3	15,7	73,6	68,8	341,7	79,5		155,7

# 351-R, 371-R SERIES

## Pull Action Latch Clamps | Dimensions

**351-R**  
**351-RSS**  
 with DESTACO®  
 Toggle Lock  
 Plus™

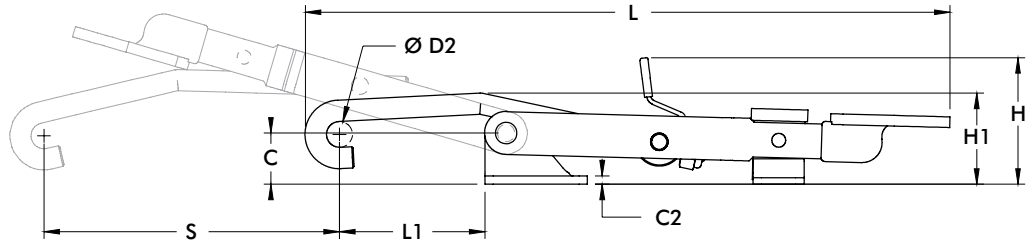

**371-R**  
**371-RSS**  
 with DESTACO®  
 Toggle Lock  
 Plus™

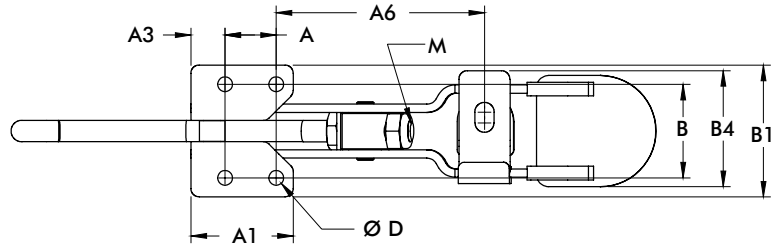
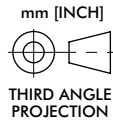

Model	A	A1	A3	A6	B	B1	B4	C	C2	ØD	H	H1
351-R	[0.75]	[1.50]	[0.50]	[3.06]	[1.37]	[1.93]	[1.70]	[0.75]	[0.12]	[0.22]	[1.85]	[1.34]
351-RSS	19,1	38,1	12,7	77,7	34,8	49,1	19,1	19,1	3,1	5,5	47,1	33,9
371-R	[1.25]	[1.94]	[0.34]	[4.73]	[1.94]	[2.63]	[2.25]	[1.42]	[0.16]	[0.34]	[2.65]	[2.22]
371-RSS	31,8	49,2	8,7	120,1	49,2	66,7	57,2	36,1	4	8,7	67,4	56,3

Model	L	L1	M	S
351-R	[9.45]	[2.13]	M8	[4.33]
351-RSS	240	54,2	M8	110
371-R	[12.74]	[2.81]	M10	[5.59]
371-RSS	323,6	71,4	M10	142

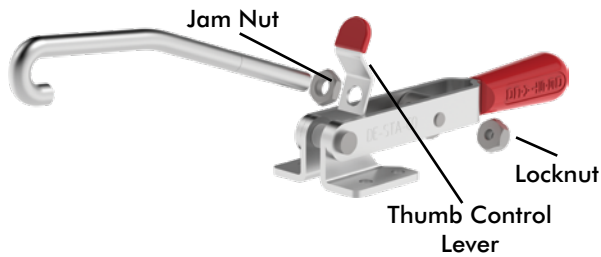
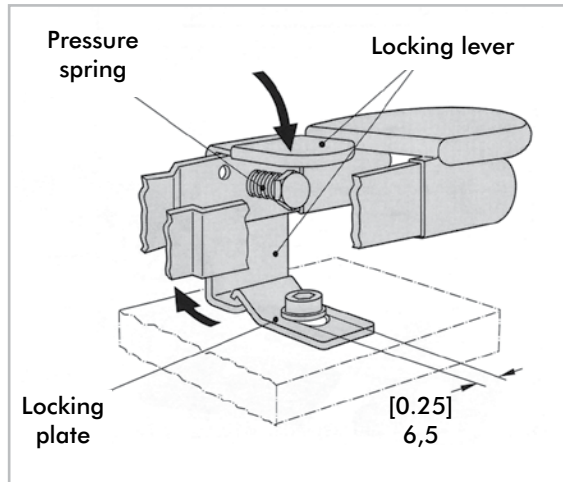

For added convenience, DESTACO Pull Action Toggle Clamps are supplied with a thumb control lever.

Replacement Thumb Control Lever	Used on Clamp Model
330-ZB1	330
351-ZB1	351, 351-B, 351-R, 351-SS, 351-RSS
371-ZB1	371, 371-R, 371-SS, 381-RSS
381-ZB1	381, 381-SS

### Model 351-R, 351-RSS, 371-R, 371-RSS

#### Information concerning the assembly and function of the clamps locking mechanism

The locking plate which is supplied with the unit must be fastened with a screw (M6 or 1/4-20) as shown in this illustration. The screw head should be flat.

#### Function

When closing the latch clamp, the locking lever engages automatically. Actuate the locking lever to open the clamp.

# 330, 351, 371, 381 SERIES

## Pull Action Latch Clamps | Replacement Hook Assembly Dimensions

Replacement Hook Assembly	Used on Clamp Model	A1	A2	B	ØC	M	Material				
330215	330	[2.00] 50,8	[1.50] 38,1	[0.75] 19,1	[0.32] 8,1	M5 x 0.8	Steel				
330215-M-25 ⓘ	330-M-25	[3.00] 76,2									
330215-M-50 ⓘ	330-M-50	[4.00] 101,6									
330215-M-100 ⓘ	330-M-100	[6.00] 152,4									
330915	330-SS	[2.00] 50,8					[3.38] 85,9	[1.63] 41,4	[0.38] 9,6	M8 x 1.25	Stainless Steel
330915-M-25 ⓘ	330-SS-M-25	[3.00] 76,2									
330915-M-50 ⓘ	330-SS-M-50	[4.00] 101,6									
330915-M-100 ⓘ	330-SS-M-100	[6.00] 152,4									
351215	351, 351-B, 351-R	[2.09] 53,1	[4.16] 105,7	[2.22] 56,4	[0.50] 12,7	M10 x 1.50	Steel				
351215-M-25 ⓘ	351-M-25 351-B-M-25 351-R-M-25	[3.09] 78,5									
351215-M-50 ⓘ	351-M-50 351-B-M-50 351-R-M-50	[4.09] 103,9									
351215-M-100 ⓘ	351-M-100 351-B-M-100 351-R-M-100	[6.09] 154,7									
351915	351-SS, 351-RSS	[2.09] 53,1					[6.94] 176,3	[3.94] 100	[0.62] 15,8	M12 x 1.75	Stainless Steel
351915-M-25 ⓘ	351-SS-M-25 351-RSS-M-25	[3.09] 78,5									
351915-M-50 ⓘ	351-SS-M-50 351-RSS-M-50	[4.09] 103,9									
351915-M-100 ⓘ	351-SS-M-100 351-RSS-M-100	[6.09] 154,7									
371215	371, 371-R	[2.94] 74,7	[4.63] 117,6	[2.50] 63,5	[0.62] 15,8	M12 x 1.75	Steel				
371215-M-25 ⓘ	371-M-25 371-R-M-25	[3.94] 100									
371215-M-50 ⓘ	371-M-50 371-R-M-50	[4.94] 125,5									
371215-M-100 ⓘ	371-M-100 371-R-M-100	[6.94] 176,3									
371915	371-SS, 371-RSS	[2.94] 74,7					[7.00] 177,8	[5.00] 127	[0.62] 15,8	M12 x 1.75	Stainless Steel
371915-M-25 ⓘ	371-SS-M-25, 371-RSS-M-25	[3.94] 100									
371915-M-50 ⓘ	371-SS-M-50 371-RSS-M-50	[4.94] 125,5									
371915-M-100 ⓘ	371-SS-M-100 371-RSS-M-100	[6.94] 176,3									
381215	381	[3.00] 76,2	[4.63] 117,6	[2.50] 63,5	[0.62] 15,8	M12 x 1.75	Steel				
381215-M-25 ⓘ	381-M-25	[4.00] 101,6									
381215-M-50 ⓘ	381-M-50	[5.00] 127									
381215-M-100 ⓘ	381-M-100	[7.00] 177,8									
381915	381-SS	[3.00] 76,2					[7.00] 177,8	[5.00] 127	[0.62] 15,8	M12 x 1.75	Stainless Steel
381915-M-25 ⓘ	381-SS-M-25	[4.00] 101,6									
381915-M-50 ⓘ	381-SS-M-50	[5.00] 127									
381915-M-100 ⓘ	381-SS-M-100	[7.00] 177,8									

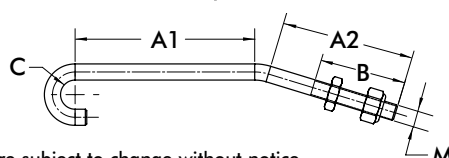

# 323, 331, 341 SERIES

## Pull Action Latch Clamps | Product Overview

### Features:

- U-hook style latch clamps are supplied with threaded U-hooks for easy adjustment
- Supplied with latch plate and patented thumb control lever for one handed operation
- DESTACO® Toggle Lock Plus™ versions available
- Stainless steel version available as **-SS** models

### Applications:

- Molding
- Closures for doors, lids, covers
- Assembly

### Also Available:

- Clamps with longer hooks available Upon Request that are 25mm, 50mm, 100mm longer than standard length
- To order clamp with longer hook, add **-M-25**, **-M-50**, or **-M-100** to the end of the model. Example: 323-**M-50**

Covered under one or more U.S./International Patents

323  
323-**SS**



323-**R**  
323-**RSS**  
with DESTACO®  
Toggle Lock  
Plus™



331  
331-**SS**



331-**R**  
331-**RSS**  
with  
DESTACO®  
Toggle Lock  
Plus™



341  
341-**SS**



341-**R**  
341-**RSS**  
with DESTACO®  
Toggle Lock  
Plus™



## Technical Information | Holding Capacities

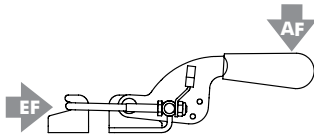

Model	Max. Holding Capacity	Weight	EF:AF	Drawing Movement	Latch Plate (Supplied)	Replacement Hook Assembly	Hook Adj. Range
323				30 [1.18]	323104-M	323215	
323-SS	1600 N [360 lbf]	0,07kg [0.15lb]	27:1		323104-MSS	323915	[0.36] 9,1
323-R				29,7 [1.17]	323104-M	323215	
323-RSS					323104-MSS	323915	
331					331005	331215	
331-SS	3200 N [720 lbf]	0,25kg [0.56lb]	32:1	44,5 [1.75]	331905	331915	[0.87] 22,1
331-R					331005	331215	
331-RSS					331905	331915	
341					341005	341215	
341-SS	8900 N [2000 lbf]	0,65kg [1.43lb]	29:1	63,5 [2.50]	341905	341915	[0.97] 24,6
341-R					341005	341215	
341-RSS					341905	341915	

EF = Exerting Force, AF = Applied Force

# 323, 323-R, 331, 341 SERIES

Pull Action Latch Clamps | Dimensions | -R/-RSS

323  
323-SS

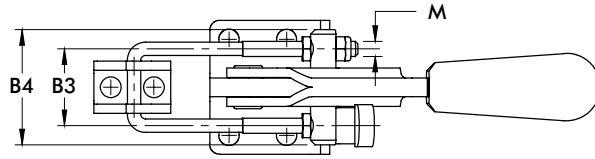

323-R  
323-RSS  
with DESTACO®  
Toggle Lock  
Plus™

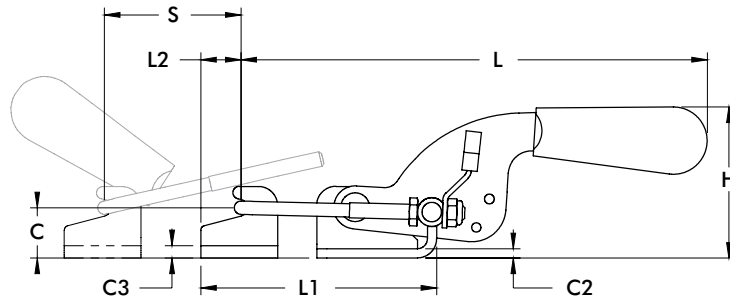

331  
331-SS



341  
341-SS

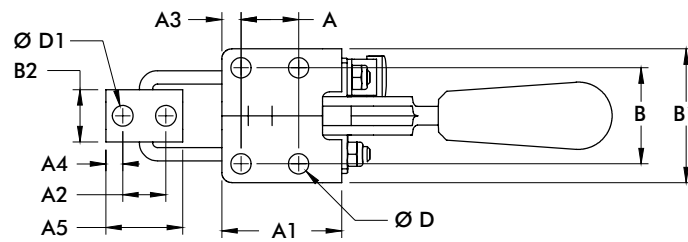
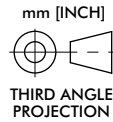

Model	A	A1	A2	A3	A4	A5	B	B1	B2	B3	B4	C	C2
323													
323-SS	[0.63]	[1.02]	[0.39]	[0.20]	[0.24]	[0.79]	[0.75]	[1.10]	[0.52]	[0.75]	[1.10]	[0.47]	[0.08]
323-R	16	26	10	5	6	20	19	28	13,2	19,1	28	12	2
323-RSS													
331	[0.75]	[1.56]	[0.56]	[0.25]	[0.22]	[1.00]	[1.26]	[1.74]	[0.68]	[1.00]	[1.50]	[0.66]	[0.12]
331-SS	19,1	39,7	14,3	6,4	5,6	25,4	32	44,3	17,3	25,4	38,1	16,7	3,1
341	[1.63]	[2.38]	[0.75]	[0.38]	[0.38]	[1.50]	[1.50]	[2.12]	[1.19]	[1.75]	[2.38]	[0.94]	[0.16]
341-SS	41,3	60,5	19,1	9,7	9,5	38,1	38,1	53,8	30,1	44,5	60,5	23,8	4

Model	C3	ØD	ØD2	H	L	L1 MAX	L2	M	S
323									
323-SS	[0.08]	[0.17]	[0.17]	[1.19]	[3.88]	[2.32]	[0.37]	M4	[1.18]
323-R	2	4,2	4,2	30,3	98,6	58,9	9,3		30
323-RSS									
331	[0.12]	[0.27]	[0.27]	[1.97]	[6.07]	[3.07]	[0.52]	M5	[1.75]
331-SS	3,1	6,7	6,9	50	154,2	78	13,3		45,5
341	[0.16]	[0.33]	[0.33]	[2.89]	[8.20]	[4.59]	[0.75]	M8	[2.50]
341-SS	4	8,5	8,5	73,4	208,3	116,6	19,1		63,5

# 331-R, 341-R SERIES

Pull Action Latch Clamps | Dimensions | -R/-RSS

**331-R**  
**331-RSS**  
 with DESTACO®  
 Toggle Lock  
 Plus™

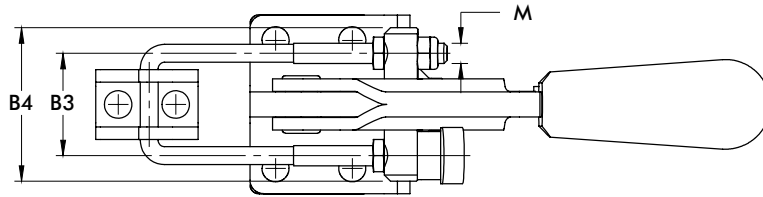

**341-R**  
**341-RSS**  
 with DESTACO®  
 Toggle Lock  
 Plus™

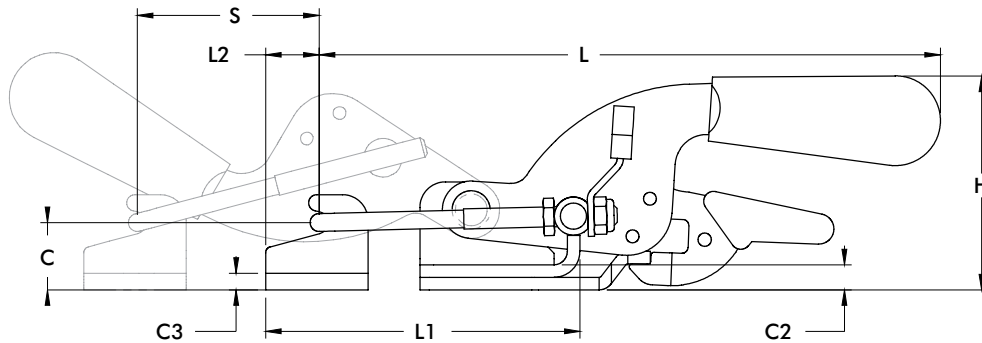

mm [INCH]  
  
 THIRD ANGLE  
 PROJECTION

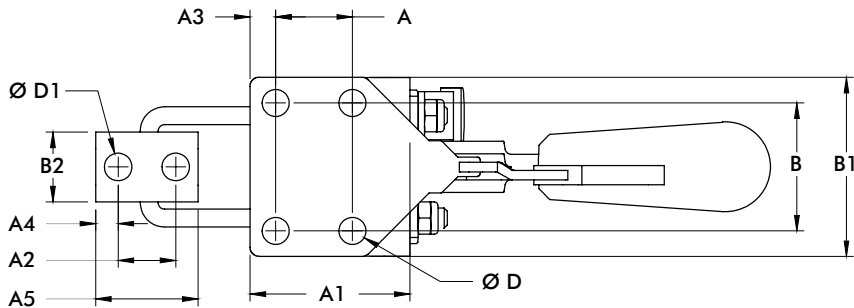

Model	A	A1	A2	A3	A4	A5	B	B1	B2	B3	B4	C	C2
331-R	[0.75]	[1.56]	[0.56]	[0.25]	[0.22]	[1.00]	[1.25]	[1.74]	[0.68]	[1.00]	[1.50]	[0.66]	[0.12]
331-RSS	19,1	39,7	14,3	6,4	5,6	25,4	31,8	44,3	17,3	25,4	38,1	16,7	3,1
341-R	[1.63]	[2.38]	[0.75]	[0.38]	[0.38]	[1.50]	[1.50]	[2.12]	[1.19]	[1.75]	[2.38]	[0.94]	[0.16]
341-RSS	41,3	60,5	19,1	9,7	9,5	38,1	38,1	53,8	30,1	44,5	60,5	23,8	4

Model	C3	ØD	ØD2	H	L	L1 MAX	L2	M	S
331-R	[0.12]	[0.27]	[0.27]	[2.01]	[6.07]	[3.07]	[0.52]	M5	[1.75]
331-RSS	3,1	6,7	6,9	53,1	154,2	78	13,3		45,5
341-R	[0.16]	[0.33]	[0.33]	[2.89]	[8.20]	[5.24]	[0.77]	M8	[2.50]
341-RSS	4	8,5	8,5	73,4	208,3	133,2	19,4		63,5

# 323, 331, 341 SERIES

## Pull Action Latch Clamps | Replacement Hook Assembly | Dimensions

Replacement Hook Assembly	Used on Clamp Model	A	B	C	M	Material
323215	323, 323-R	[2.12] 53,8	[0.94] 23,8	[0.75] 19,1	M4 x 0.7	Steel
323215-M-25 ⓘ	323-M-25, 323-R-M-25	[3.12] 79,2				
323215-M-50 ⓘ	323-M-50, 323-R-M-50	[4.12] 104,6				
323215-M-100 ⓘ	323-M-100, 323-R-M-100	[6.12] 155,4				
323915	323-SS, 323-RSS	[2.12] 53,8				Stainless Steel
323915-M-25 ⓘ	323-SS-M-25, 323-RSS-M-25	[3.12] 79,2				
323915-M-50 ⓘ	323-SS-M-50, 323-RSS-M-50	[4.12] 104,6				
323915-M-100 ⓘ	323-SS-M-100, 323-RSS-M-100	[6.12] 155,4				
331215	331, 331-R	[3.00] 76,2	[1.50] 38,1	[1.00] 25,4	M5 x 0.8	Steel
331215-M-25 ⓘ	331-M-25, 331-R-M-25	[4.00] 101,6				
331215-M-50 ⓘ	331-M-50, 331-R-M-50	[5.00] 127				
331215-M-100 ⓘ	331-M-100, 331-R-M-100	[7.00] 177,8				
331915	331-SS, 331-RSS	[3.00] 76,2				Stainless Steel
331915-M-25 ⓘ	331-SS-M-25, 331-RSS-M-25	[4.00] 101,6				
331915-M-50 ⓘ	331-SS-M-50, 331-RSS-M-50	[5.00] 127				
331915-M-100 ⓘ	331-SS-M-100, 331-RSS-M-100	[7.00] 177,8				
341215	341, 341-R	[4.31] 109,5	[1.97] 50	[1.75] 44,5	M8 x 1.25	Steel
341215-M-25 ⓘ	341-M-25, 341-R-M-25	[5.31] 135				
341215-M-50 ⓘ	341-M-50, 341-R-M-50	[6.31] 160,2				
341215-M-100 ⓘ	341-M-100, 341-R-M-100	[8.31] 211				
341915	341-SS, 341-RSS	[4.31] 109,5				Stainless Steel
341915-M-25 ⓘ	341-SS-M-25, 341-RSS-M-25	[5.31] 135				
341915-M-50 ⓘ	341-SS-M-50, 341-RSS-M-50	[6.31] 160,2				
341915-M-100 ⓘ	341-SS-M-100, 341-RSS-M-100	[8.31] 211				

ⓘ This item is available upon request.

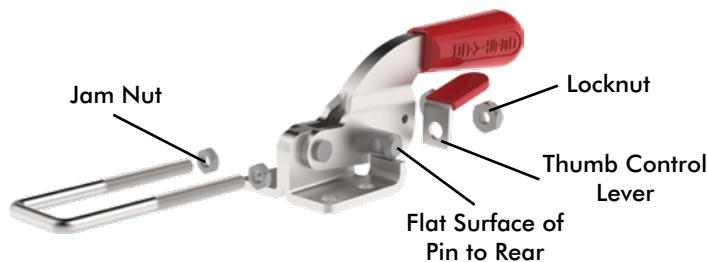

For added convenience, DESTACO Pull Action Toggle Clamps are supplied with a thumb control lever that allows the clamp to be operated with one hand.

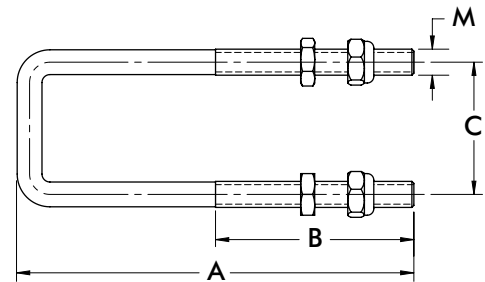

Replacement Thumb Control Lever	Used on Clamp Model
324-ZB1	323, 323-SS
330-ZB1	331, 331-SS 331-R, 331-RSS
341-ZB1	341, 341-SS 341-R, 341-RSS

# 375 SERIES

## Pull Action Latch Clamps | Dimensions

### Features:

- Heavy duty U-hook style latch clamps are supplied with threaded U-hooks for easy adjustment
- Supplied patented thumb control lever for one handed operation
- DESTACO® Toggle Lock Plus™ versions available

### Applications:

- Molding
- Closures for doors, lids, covers
- Assembly

### Also Available:

- Clamps with longer hooks available Upon Request that are 25mm, 50mm, 100mm longer than standard length
- To order clamp with longer hook, add **-M-25**, **-M-50**, or **-M-100** to the end of the model. Example: 375-**M-50**

Covered under one or more U.S./International Patents

375



**375-R**  
with DESTACO®  
Toggle Lock  
Plus™



**375-B**

Weld-on  
Mounting



**375-BR** ⓘ

Weld-on  
Mounting  
with DESTACO®  
Toggle Lock  
Plus™



375509  
Cleat



385102  
Optional  
Latch Plate  
for 375 and  
375-R



## Technical Information | Holding Capacities

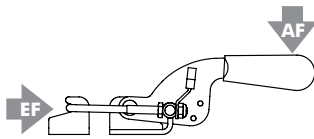

Model	Max. Holding Capacity	Weight	EF:AF	Drawing Movement	Latch Plate	Replacement Hook Assembly	Hook Adj. Range
375	[4000 lbf] 17800 N	[2.94lb] 1,33kg	44:1	88,9 [3.50]	385102 (Optional)	375215	[0.81] 20,5
375-R		[3.0lb] 1,36kg					
375-B		[2.56lb] 1,16kg			375509 (Cleat Supplied)		
375-BR ⓘ		[2.62lb] 1,19kg					

ⓘ This item is available upon request. **EF** = Exerting Force, **AF** = Applied Force



# 375, 375-R, 5-B, 375-BR SERIES

## Pull Action Latch Clamps | Dimensions

375

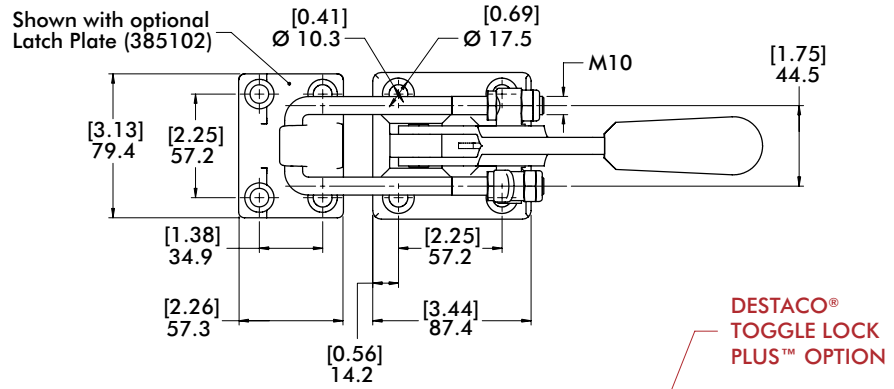

375-R

with DESTACO® Toggle Lock Plus™

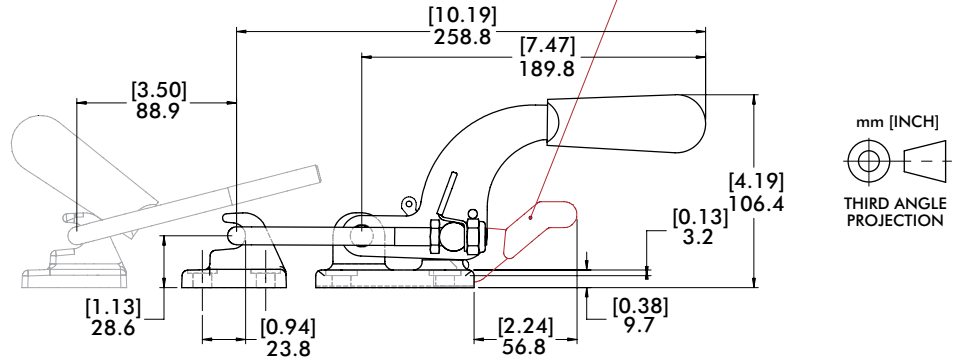

375-B

Weld-on Mounting

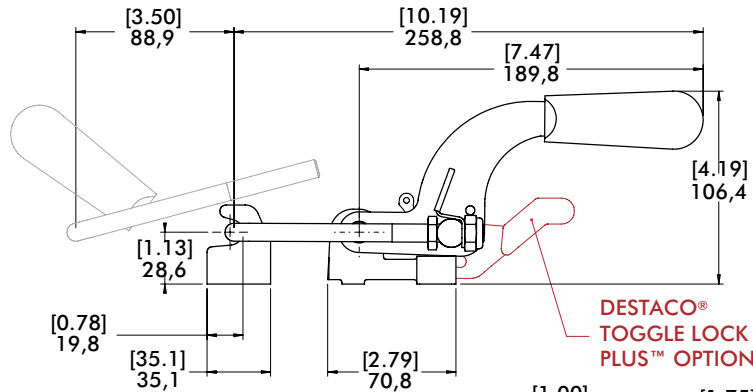

375-BR

Weld-on Mounting with DESTACO® Toggle Lock Plus™

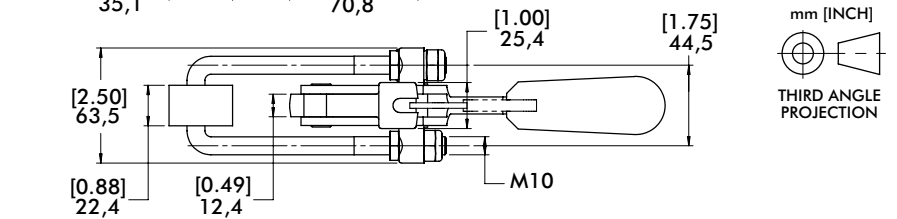

Replacement Hook Assembly	A	B	C	M
375215	[5.72] 145	50,8 [2.00]	[1.75] 44,5	M10 x 1.50

Hook assembly includes (2) jam nuts and (2) locknuts. Longer hook lengths available Upon Request. 375215-M-25, 375215-M-50, 375215-M-100

Replacement Thumb Control Lever	Used on Clamp Model
375-ZB1	375, 375-B 375-R, 375-BR

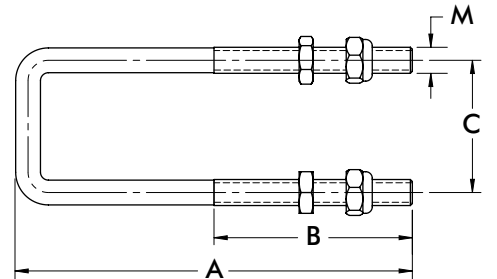

# 385 SERIES

## Pull Action Latch Clamps | Dimensions

### Features:

- Heavy duty U-hook style latch clamps are supplied with threaded U-hooks for easy adjustment
- Supplied with patented thumb control lever for one handed operation
- DESTACO® Toggle Lock Plus™ versions available

### Applications:

- Molding
- Closures for doors, lids, covers
- Assembly

### Also Available:

- Clamps with longer hooks available Upon Request that are 25mm, 50mm, 100mm longer than standard length
- To order clamp with longer hook, add **-M-25**, **-M-50**, or **-M-100** to the end of the model. Example: 385-**M-50**

Covered under one or more U.S./International Patents

**385**  
**385-SS**



**385-R**  
**385-RSS**  
with DESTACO®  
Toggle Lock  
Plus™



**385-L**  
Low Profile  
Handle



**385102**  
Optional  
Latch Plate  
for 385, 385-R  
and 385-L

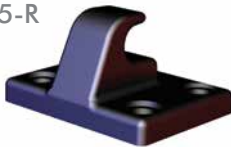

**385902**  
Optional Stainless  
Latch Plate for  
385-SS and  
385-RSS



## Technical Information | Holding Capacities

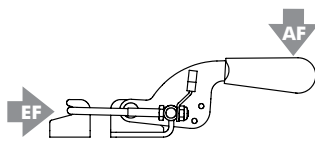

Model	Max. Holding Capacity	Weight	EF:AF	Drawing Movement	Latch Plate/Cleat (Optional)	Replacement Hook Assembly	Hook Adj. Range
385		[3.3lb] 1,50kg					
385-SS					385102	385215	
385-R	[7500 lbf] 33300 N	[3.4lb] 1,54kg	44:1	55,6 [2.19]	385902 (Stainless Steel)	385915 (Stainless Steel)	[1.36] 34,5
385-L		[3.3lb] 1,50kg					

ⓘ This item is available upon request. **EF** = Exerting Force, **AF** = Applied Force

# 385, 385-R, 385-L SERIES

## Pull Action Latch Clamps | Dimensions

**385**  
**385-SS**



**385-R**  
**385-RSS**  
with DESTACO®  
Toggle Lock  
Plus™

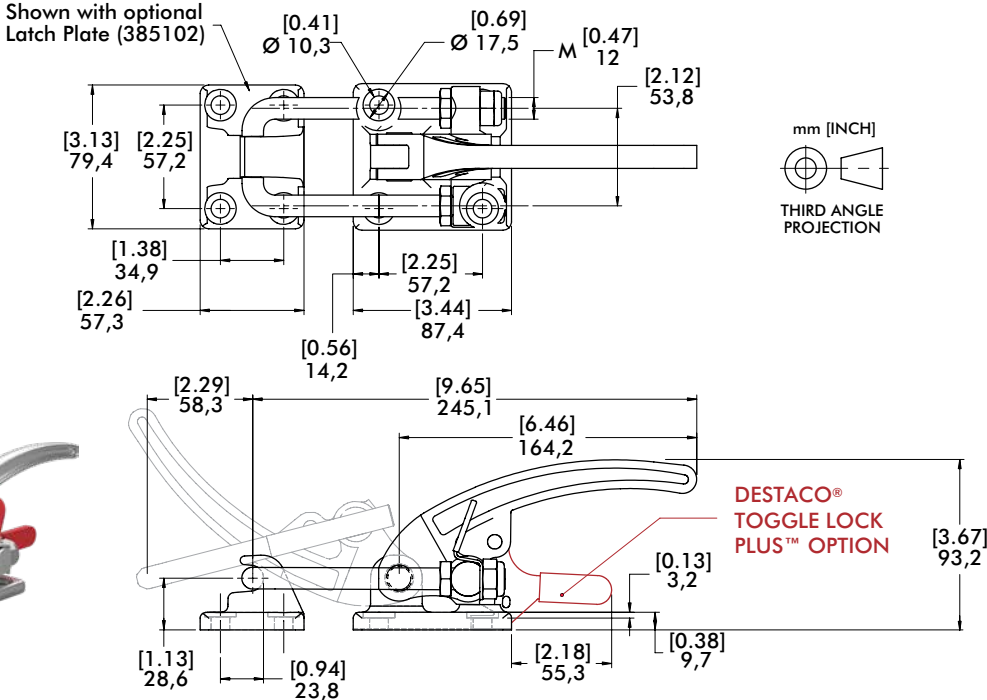

**385-L**  
Low Profile  
Handle

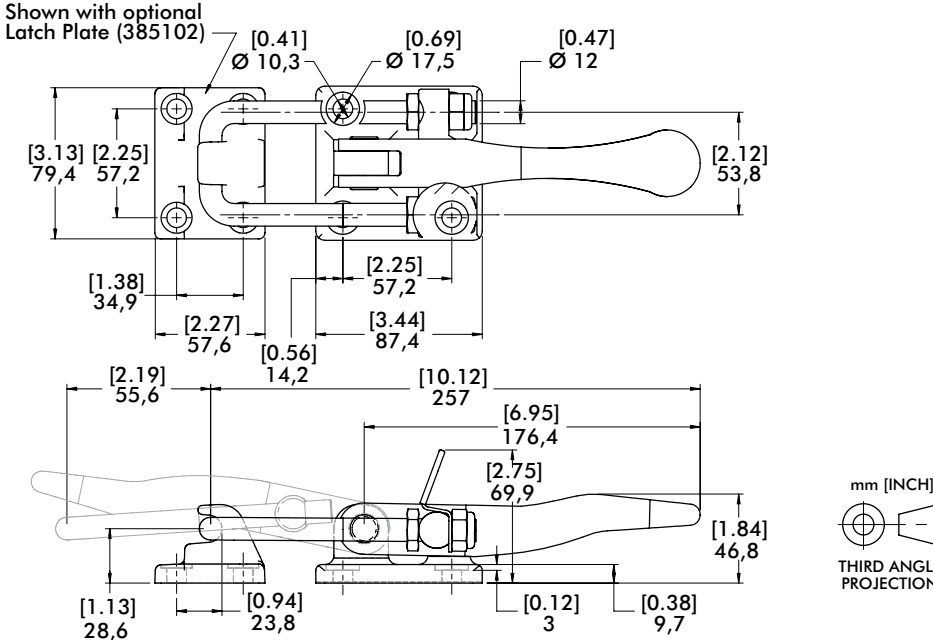

# 385, 385-R, 385-L SERIES

Pull Action Latch Clamps | Replacement Hook Assembly | Dimensions

Replacement Hook Assembly	Used on Clamp Model	A	B	C	M	Material
385215	385, 385-R, 385-L	[5.72] 145,3			M12 x 1.75	Steel
385215-M-25 ⓘ	385-M-25, 385-R-M-25 385-L-M-25	[6.72] 170,7				
385215-M-50 ⓘ	385-M-50, 385-R-M-50 385-L-M-50	[7.72] 196				
385215-M-100 ⓘ	385-M-100, 385-R-M-100 385-L-M-100	[9.72] 247				
385915	385-SS, 385-RSS	[5.72] 145,3	[2.75] 70	[2.12] 53,8	M12 x 1.75	Stainless Steel
385915-M-25 ⓘ	385-SS-M-25, 385-RSS-M-25	[6.72] 170,7				
385915-M-50 ⓘ	385-SS-M-50, 385-RSS-M-50	[7.72] 196				
385915-M-100 ⓘ	385-SS-M-100, 385-RSS-M-100	[9.72] 247				

ⓘ This item is available upon request.

Replacement Thumb Control Lever	Used on Clamp Model
385-ZB1	385, 385-R, 385-L, 385-SS, 385-RSS

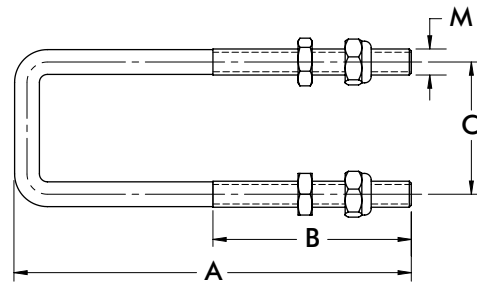

# 324, 334, 344, 374 SERIES

## Pull Action Latch Clamps | Product Overview

### Features:

- U-hook style latch clamps supplied with threaded U-hooks for easy adjustment
- Supplied with latch plate (except 374) and patented thumb control lever for one handed operation.
- DESTACO® Toggle Lock Plus™ versions available
- Stainless steel available as **-SS** models.

### Applications:

- Molding
- Closures for doors, lids, covers
- Assembly

### Also Available:

- Clamps with longer hooks available Upon Request that are 25mm, 50mm, 100mm longer than standard length
- To order clamp with longer hook, add **-M-25**, **-M-50**, or **-M-100** to the end of the model. Example: 324-**M-50**

Covered under one or more U.S./International Patents



## Technical Information | Holding Capacities

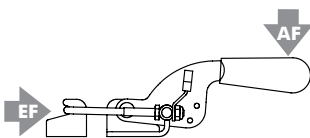

Model	Max. Holding Capacity	Weight	EF:AF	(S) Drawing Movement	Latch Plate (Supplied)	Replacement Hook Assembly	Hook Adj. Range
324					324101	324215	
324-SS	[500 lbf] 2200 N	[0.25lb] 0,11kg		38,7 [1.53]	324901	324915	11.9 [0.47]
324-R			31:1		324101	324215	
324-RSS					324901	324915	
334					334101	334215	
334-SS	[1000 lbf] 4450 N	[0.60lb] 0,27kg		51,7 [2.04]	334901	334915	19.3 [0.76]
334-R					334101	334215	
334-RSS					334901	334915	
344					344101	344215	
344-SS	[2000 lbf] 8900 N	[1.50lb] 0,68kg	45:1	62,4 [2.46]	344901	344915	31 [1.22]
344-R					344101	344215	
344-RSS					344901	344915	
374	[4000 lbf] 17800 N	[2.10lb] 0,95kg	36:1	44,5 [1.75]	None*	374215	53.8 [2.12]

EF = Exerting Force, AF = Applied Force \*375509 Latch Plate may be used as an alternate.

# 324, 334, 344, 374 SERIES

Pull Action Latch Clamps | Dimensions | -SS

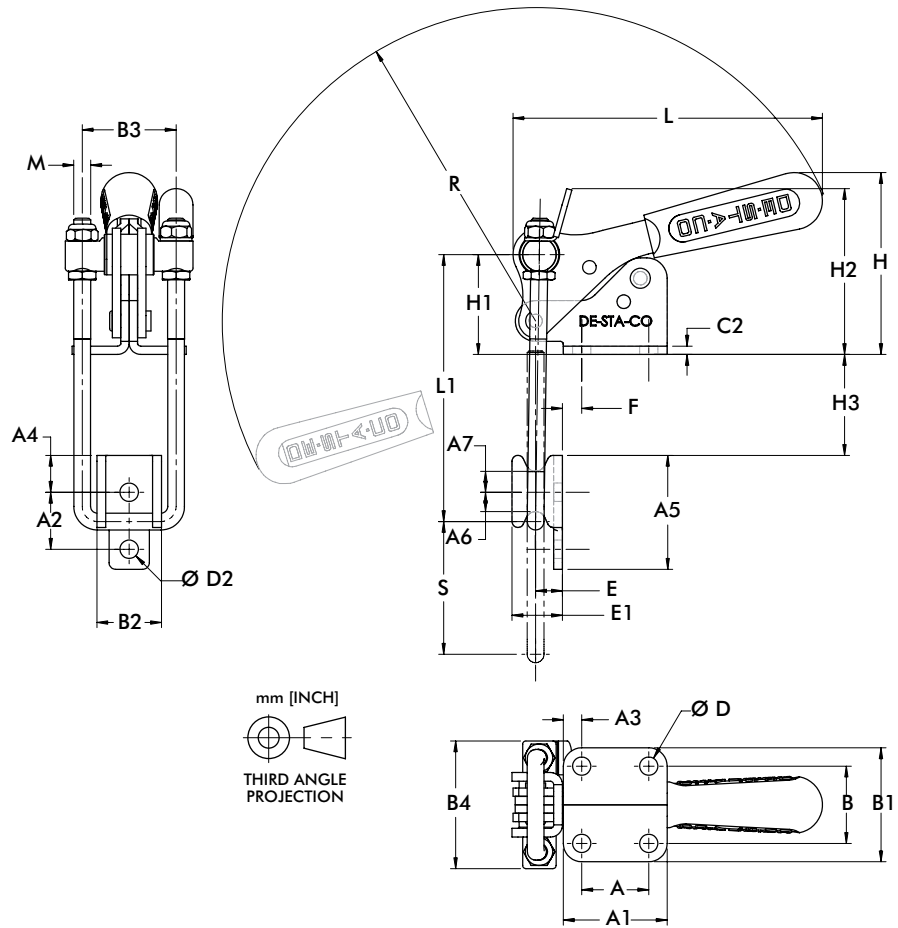

Model	A	A1	A2	A3	A4	A5	A6	A7	B	B1	B2	B3	B4	C2
324	[0.50]	[1.00]	[0.56]	[0.25]	[0.28]	[1.00]	[0.19]	[0.19]	[0.88]	[1.38]	[0.53]	[0.81]	[1.19]	[0.09]
324-SS	12,7	25,4	14,2	6,4	7,1	25,4	4,8	4,8	22,4	35,1	13,5	20,7	30,2	2,4
334	[0.75]	[1.31]	[0.81]	[0.28]	[0.41]	[1.50]	[0.28]	[0.28]	[1.00]	[1.56]	[0.68]	[1.13]	[1.63]	[0.12]
334-SS	19,1	33,3	20,6	7,1	10,4	38,1	7,1	7,1	25,4	39,6	17,4	28,7	41,4	3,1
344		[1.94]	[1.06]	[0.35]	[0.69]	[2.13]	[0.36]	[0.39]	[1.44]	[2.12]	[1.20]		[2.38]	[0.16]
344-SS	[1.25]	49,3	27	8,0	17,5	54	9,1	9,9	36,6	53,8	30,6	[1.75]	60,5	4
374	31,8	[2.43]	--	[0.68]	--	--	--	--	[1.50]	[2.50]	--	44,5	[2.36]	[0.37]
		61,7		17,3					38,1	63,5			60	9,4

Model	ØD	ØD2	F	H	H1	H2	H3	E	E1	L	L1 MAX	R	M	S
324	[0.20]	[0.17]	[0.25]	[1.91]	[1.10]	[1.97]	[0.92]	[0.19]	[0.38]	[3.49]	[2.56]	[3.49]	M4	[1.53]
324-SS	5,1	4,3	6,4	48,5	28	50,1	[23,4]	4,4	9,7	88,7	65,1	88,8		38,7
334	[0.28]	[0.22]	[0.28]	[2.37]	[1.55]	[2.68]	[1.34]	[0.35]	[0.63]	[4.10]	[3.70]	[4.12]	M6	[2.04]
334-SS	7,1	5,6	7,1	60,1	39,3	68	34	8,8	16	104,2	94	104,5		51,8
344	[0.34]	[0.34]	[0.35]	[3.39]	[1.86]	[7.09]	[1.73]	[0.50]	[0.94]	[5.77]	[5.00]	[5.84]	M8	[2.46]
344-SS	8,6	8,6	8,9	86,1	47,3	78,6	49,1	12,7	23,8	146,6	126,9	148,4		62,4
374	[0.41]	--	--	[2.38]	[1.43]	--	--	--	--	[6.60]	[6.04]	[6.04]	M10	[1,75]
	10,3			60,5	36,3					167,8	153,5	153,5		44,5

# 324-R, 334-R, 344-R SERIES

Pull Action Latch Clamps | Dimensions | -R/-RSS

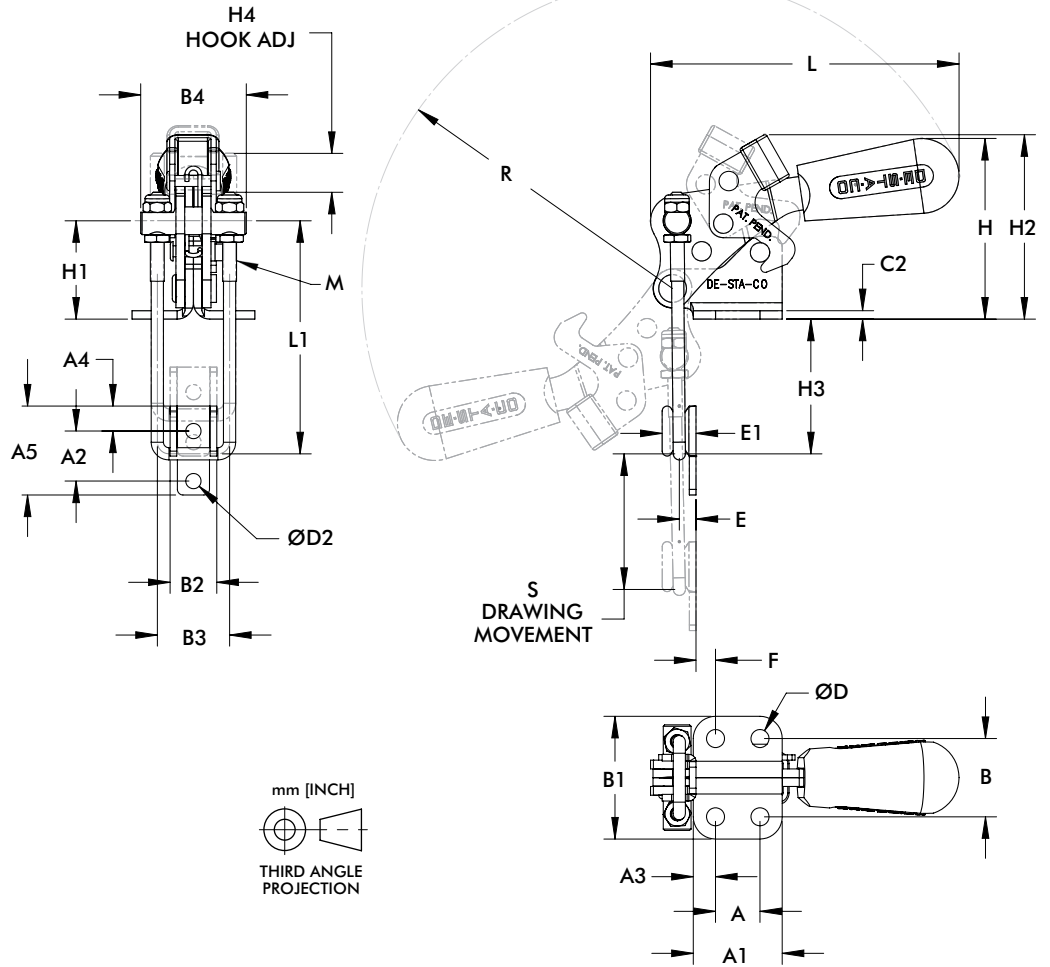

Model	A	A1	A2	A3	A4	A5	B	B1	B2	B3	B4	C2	D
324-R	[.50]	[1.00]	[.56]	[.25]	[.28]	[1.00]	[0.88]	[1.38]	[.52]	[0.81]	[0.44]	[0.09]	[0.20]
324-RSS	12,7	25,4	14,3	6,4	7,1	25,4	22,4	35,1	13,3	20,6	11,1	2,4	5,2
334-R	[.75]	[1.38]	[.81]	[.27]	[.41]	[2.13]	[1.00]	[1.56]	[0.68]	[1.13]	[1.63]	[0.12]	[0.28]
334-RSS	19,1	34,9	20,6	7,0	10,3	54,0	25,4	39,6	17,3	28,6	41,3	3,1	7,1
344-R	[1.25]	[1.94]	[1.06]	[.34]	[0.69]	[2.13]	[1.44]	[2.13]	[1.21]	[1.75]	[2.38]	[0.16]	[0.34]
344-RSS	31,8	49,1	27,0	8,7	17,5	54	36,6	54	30,6	44,5	60,5	4	8,6

Model	D2	E	E1	F	H	H1	H2	H3	H4	L	L1	M	S	R
324-R	[0.17]	[0.20]	[0.17]	[0.22]	[2.03]	[1.11]	[2.07]	[1.52]	[.44]	[3.47]	[2.62]	M4	[1.53]	[3.49]
324-RSS	4,4	5,2	4,4	5,6	51,6	28,1	52,7	38,5	11,1	88,1	66,6	M4	38,7	88,8
334-R	[0.22]	[0.35]	[0.63]	[0.18]	[2.37]	[1.55]	[2.55]	[2.22]	[0.86]	[4.12]	[3.76]	M6	[2.04]	[4.10]
334-RSS	5,6	8,8	15,9	4,5	60,2	39,3	64,7	56,3	21,8	104,6	95,6	M6	51,7	104,2
344-R	[0.34]	[0.50]	[0.94]	[0.36]	[3.40]	[1.86]	[3.39]	[3.17]	[1.22]	[5.77]	[5.04]	M8	[2.46]	[5.90]
344-RSS	8,7	12,7	23,9	9,1	86,5	47,3	86,0	80,8	31	146,5	128,0	M8	62,4	150

# 324, 334, 344, 374 SERIES

Pull Action Latch Clamps | Replacement Hook Assembly | Dimensions

Replacement Hook Assembly	Used on Clamp Model	A	B	C	M	Material
324215	324, 324-R	[3.00] 76	[1.00] 25,4	[0.81] 20,6	M4X0.7	Steel
324215-M-25 ⓘ	324-M-25 324-R-M-25	[4.00] 101,6				
324215-M-50 ⓘ	324-M-50 324-R-M-50	[5.00] 127				
324215-M-100 ⓘ	324-M-100 324-R-M-100	[7.00] 178				
324915	324-SS, 324-RSS	[3.00] 76	[1.50] 38,1	[1.13] 28,7	M6X1.0	Stainless Steel
324915-M-25 ⓘ	324-SS-M-25	[4.00] 101,6				
324915-M-50 ⓘ	324-SS-M-50	[5.00] 127				
324915-M-100 ⓘ	324-SS-M-100	[7.00] 178				
334215	334, 334-R	[4.31] 109,5	[2.25] 57,2	[1.75] 44,5	M8X1.25	Steel
334215-M-25 ⓘ	334-M-25 334-R-M-25	[5.31] 135				
334215-M-50 ⓘ	334-M-50 334-R-M-50	[6.31] 160,3				
334215-M-100 ⓘ	334-M-100 334-R-M-100	[8.31] 211				
334915	334-SS, 334-RSS	[4.31] 109,5	[3.25] 82,6		M10X1.50	Steel
334915-M-25 ⓘ	334-SS-M-25	[5.31] 135				
334915-M-50 ⓘ	334-SS-M-50	[6.31] 160,3				
334915-M-100 ⓘ	334-SS-M-100	[8.31] 211				
344215	344, 344-R	[5.81] 147,5				Stainless Steel
344215-M-25 ⓘ	344-M-25 344-R-M-25	[6.81] 173				
344215-M-50 ⓘ	344-M-50 344-R-M-50	[7.81] 198,5				
344215-M-100 ⓘ	344-M-100 344-R-M-100	[9.81] 249,2				
344915	344-SS, 344-RSS	[5.81] 147,5				
344915-M-25 ⓘ	344-SS-M-25	[6.81] 173				
344915-M-50 ⓘ	344-SS-M-50	[7.81] 198,5				
344915-M-100 ⓘ	344-SS-M-100	[9.81] 249,2				
374215	374	[6.50] 165				
374215-M-25 ⓘ	374-M-25	[7.50] 190,5				
374215-M-50 ⓘ	374-M-50	[8.50] 216				
374215-M-100 ⓘ	374-M-100	[10.50] 266,5				

Hook assemblies are supplied with (2) jam nuts and (2) locknuts.

ⓘ This item is available upon request.

Replacement Thumb Control Lever	Used on Clamp Model
324-ZB1	324, 324-SS
334-ZB1	334, 334-SS
344-ZB1	344, 344-SS
375-ZB1	374

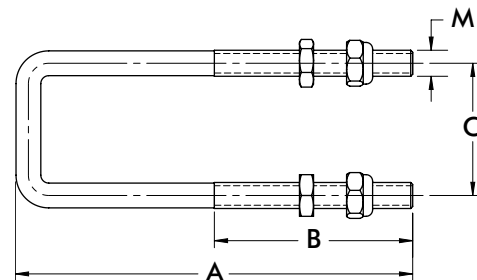



# 301, 311 SERIES

## Pull Action Latch Clamps | Product Overview

### Features:

- Fixed stop automatically limits handle travel at various clamping positions once the clamp is installed
- Model 301 available in stainless steel as 301-SS

### Applications:

- Molding
- Closures for doors, lids, covers
- Assembly

301  
301-SS



311



## Technical Information | Holding Capacities | Dimensions

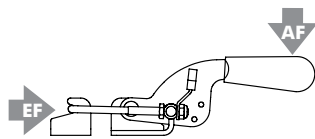

Model	Max. Holding Capacity	Weight	EF:AF	Drawing Movement
301	1670 N [375 lbf]	0,32kg [0.70lb]	29:1	101,6 [4.00]
301-SS	2000 N [450 lbf]			
311	5340 N [1200 lbf]	0,53kg [1.16lb]	31:1	85,9 [3.38]

EF = Exerting Force, AF = Applied Force

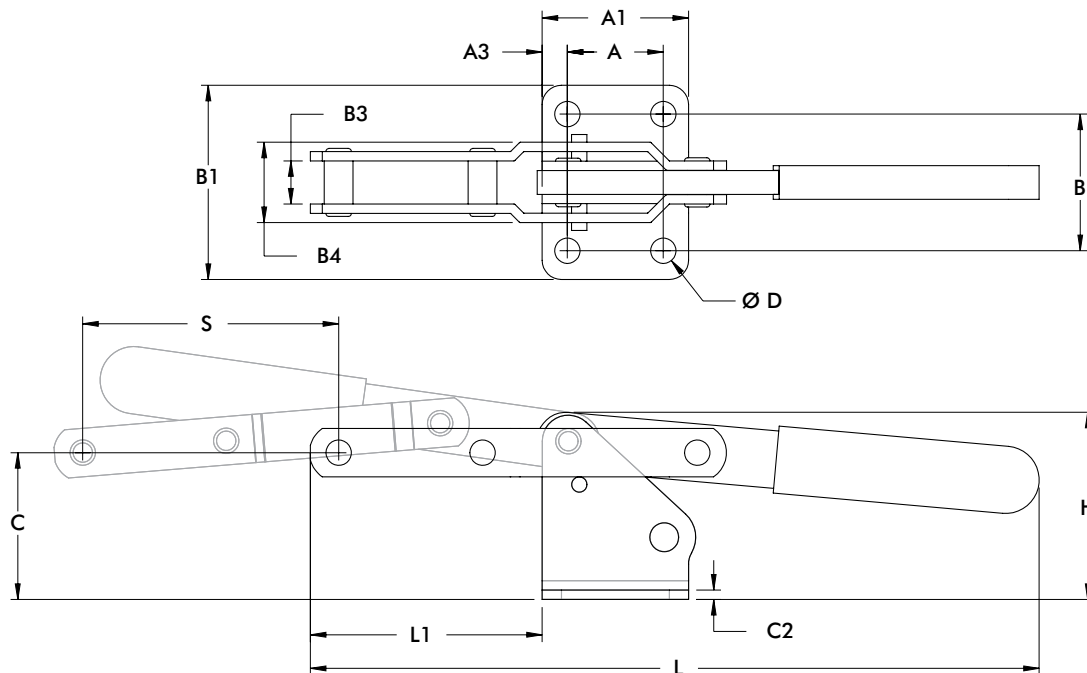

mm [INCH]  
THIRD ANGLE PROJECTION

Model	A	A1	A3	B	B1	B3	B4	C	C2	ØD	H	L	L1	S
301	[0.75]	[1.38]	[0.32]	[1.25]	[1.75]	[0.56]	[1.04]	[1.52]	[0.12]	[0.28]	[1.91]	[8.33]	[3.04]	[4.00]
301-SS	19,1	35,1	8	31,8	44,5	14,1	26,4	38,6	3,1	7,1	48,4	211,5	77,1	101,6
311	[1.25]	[1.91]	[0.33]	[1.78]	[2.53]	[0.56]	[1.05]	[1.91]	[0.12]	[0.33]	[2.44]	[9.49]	[3.02]	[3.88]
	31,8	48,4	8,3	45,2	64,3	14,3	26,6	48,6	3,1	8,4	61,9	241,2	76,7	85,9

# 3011 SERIES

## Pull Action Latch Clamps | Product Overview

### Features:

- Heavy duty cast steel or stainless steel construction with ergonomic handle
- Replaceable stainless steel pivot pins

### Applications:

- Molding
- Closures for doors, lids, covers
- Assembly

3011



## Technical Information | Holding Capacities | Dimensions

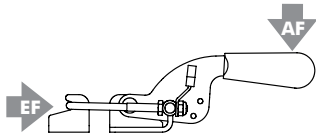

Model	Max. Holding Capacity	Weight	EF:AF	Drawing Movement
3011	8900 N [2000 lbf]	0,91kg [2.00lb]	31:1	76,2 [3.00]

EF = Exerting Force, AF = Applied Force

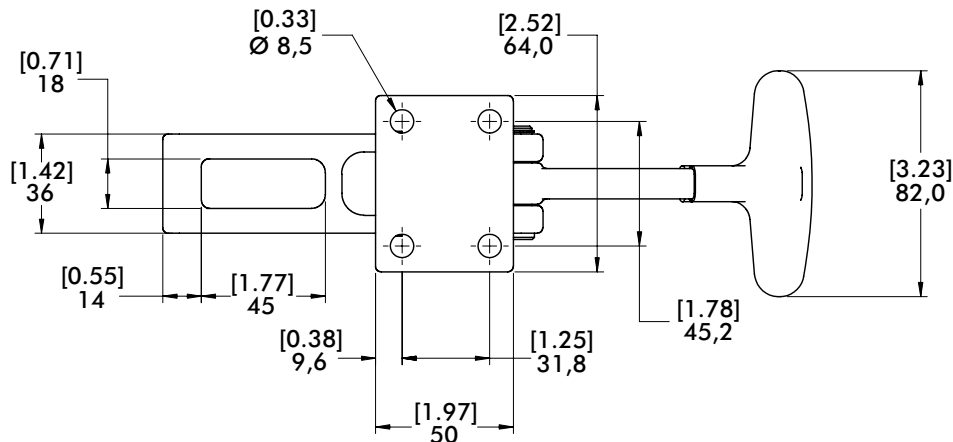
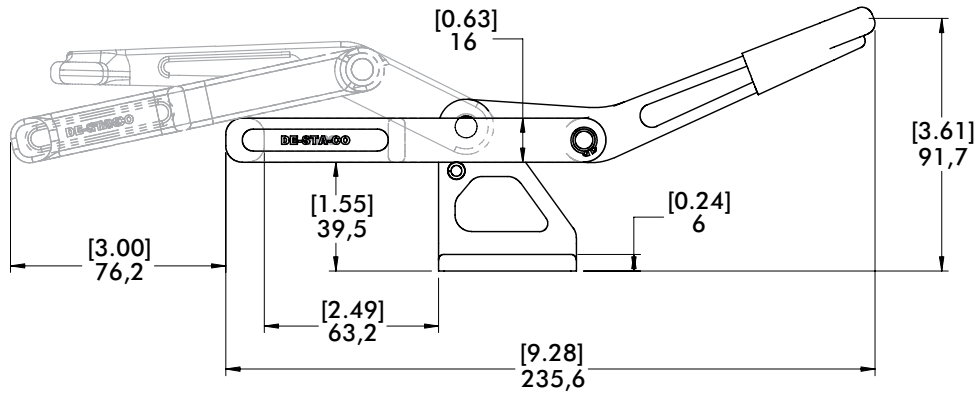

mm [INCH]  
THIRD ANGLE PROJECTION

### Features:

- Heavy duty cast steel clamps are designed to withstand the harshest environments
- Ideally suit for parting line clamping of rotational molds
- Replaceable stainless steel pivot pins

### Applications:

- Molding
- Closures for doors, lids, covers

### Also Available:

- Keeper plate
- Tapered bolt assembly

353-35

353-65



### Technical Information | Holding Capacities

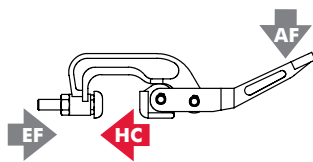

Model	Max. Holding Capacity	Weight	EF:AF	Drawing Movement	L	K	Keeper Plate (included)	Tapered Bolt Assembly (included)
353-35	[2800 lbf] 12460 N	[2.10lb] 0,95kg	23:1	12 [0.47]	[9.50] 241,5	[1.38] 35	353004	353908
353-65	[2100 lbf] 9350 N	[2.30lb] 1,04kg	27:1		[10.69] 271,5	[2.56] 65	353004	

EF = Exerting Force, AF = Applied Force

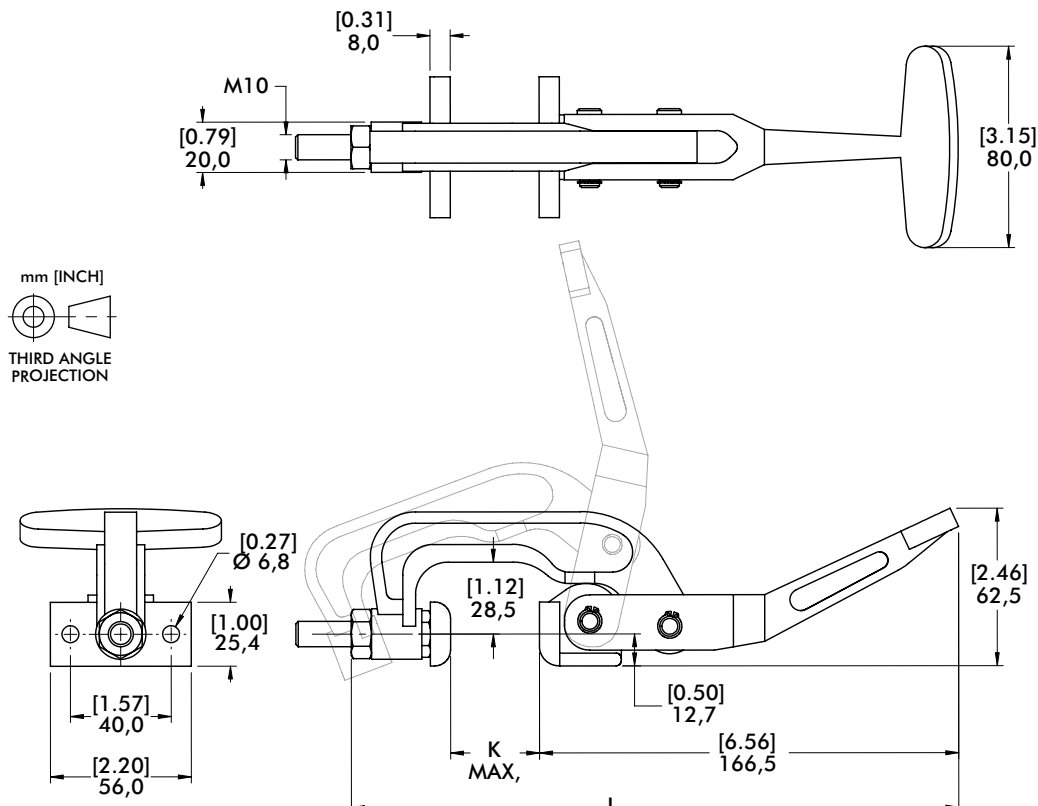

# 325 SERIES

## Squeeze Action Plier Clamps | Product Overview

### Features:

- Designed for attachment by welding or using mounting holes
- Available in stainless steel as **-SS** version

### Applications:

- Molding
- Closures for doors, lids, covers

### Also Available:

See page MC-ACC-1 for accessories

325,  
325-SS



## Technical Information | Holding Capacities

Model	Max. Holding Capacity	Weight	Jaw Opening	Spindle (Supplied)
325	3560 N [800 lbf]	0,54kg [1.18lb]	90°	325203-M
325-SS				325943-M

## Dimensions

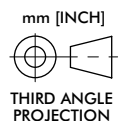
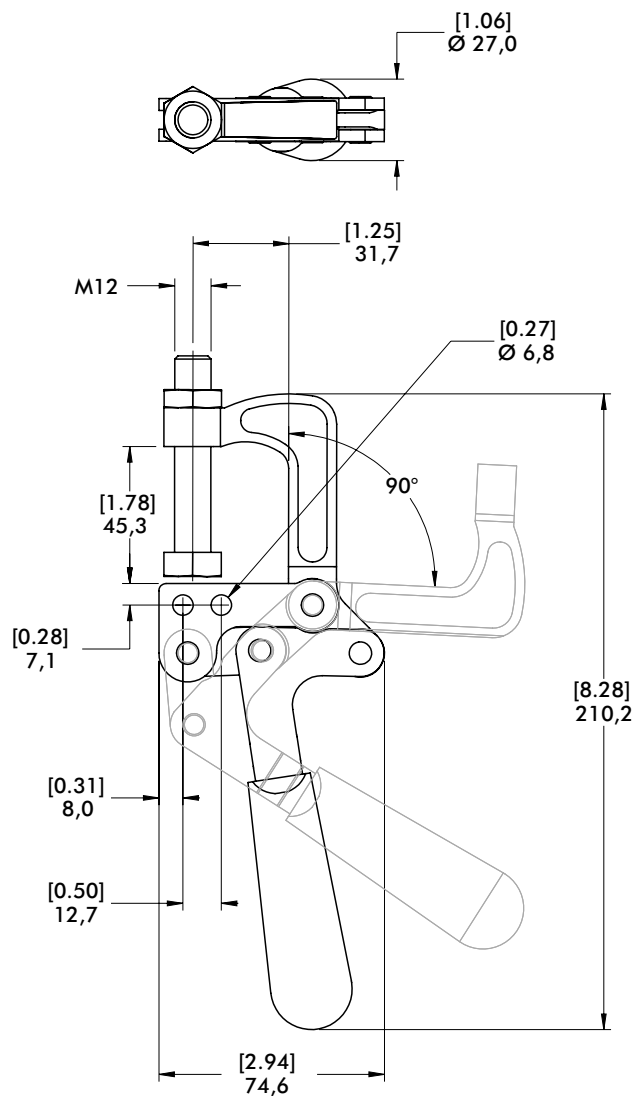

### Features:

- Designed for welding or bolting at any point along the mounting bar
- Includes M10 swivel foot spindle
- Model 345-G includes sliding jaw with spindle

### Applications:

- Welding fixtures
- Assembly fixtures
- Closures for doors, lids, covers

### Also Available:

See page MC-ACC-1 for accessories

345,  
345-G ⓘ



### Technical Information | Holding Capacities

Model	Max. Holding Capacity	Weight	Jaw Opening	Spindle (Supplied)
345	3560 N [800 lbf]	1,22kg [2.69lb]	85°	468206-M
345-G ⓘ		1,40kg [3.09lb]		468206-M 210203-M

ⓘ This item is available upon request.

### Dimensions

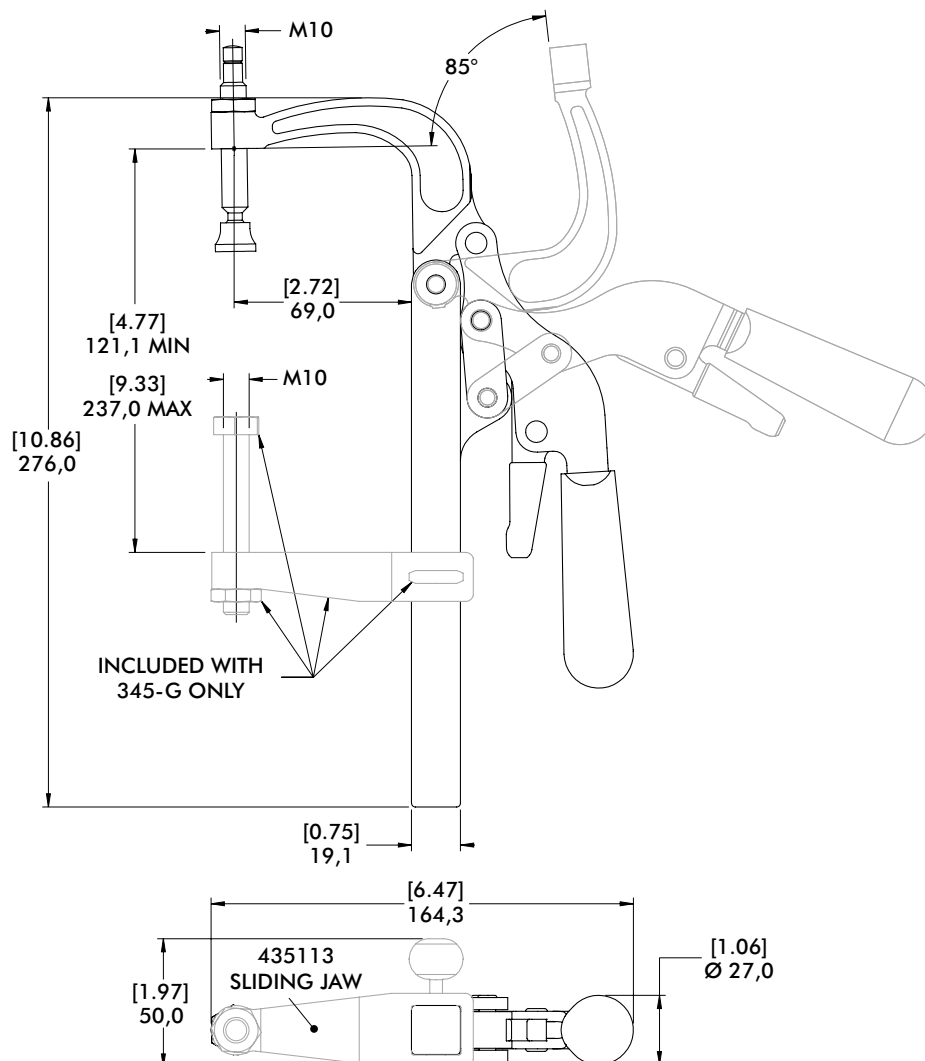

# 424, 441 SERIES

## Squeeze Action Plier Clamps | Product Overview

### Features:

- Compact clamps with forged alloy steel construction for high strength
- Versions ending with (-2) are supplied with two adjustable spindles

### Applications:

- Welding
- Assembly

### Also Available:

See page MC-ACC-1 for accessories



## Technical Information | Holding Capacities | Dimensions

Model	Max. Holding Capacity	Weight	(K5) Maximum Clamping Thickness	Spindle (Supplied)
424	900 N [200 lbf]	0,14kg [0.31lb]	16 [0.63]	424208-M
424-2			7,4 [0.29]	(2X) 431208-M
441	1560 N [350 lbf]	0,29kg [0.63lb]	23,3 [1.03]	441203-M
441-2			20,8 [0.82]	(2X) 461203-M

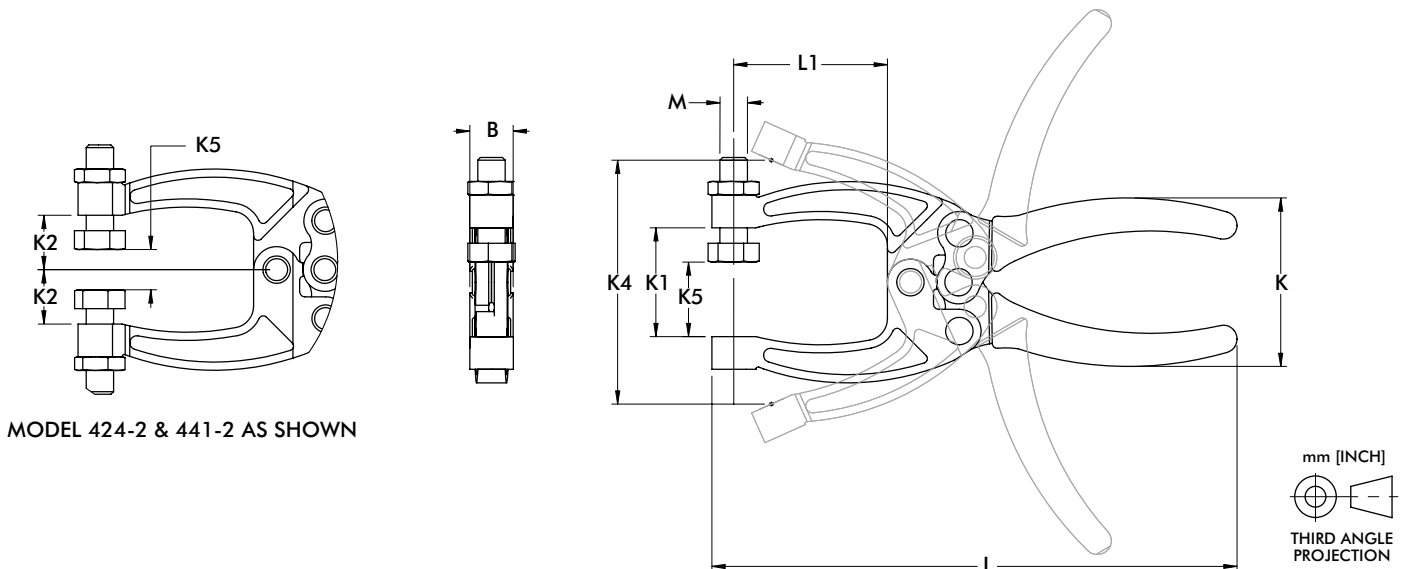

MODEL 424-2 & 441-2 AS SHOWN

Model	B	K	K1	K2	K4	L	L1	M
424	[0.50]	[1.91]	[1.00]	[0.50]	[2.06]	[4.63]	[1.08]	M6
424-2	12.8	48.5	25.4	12.7	52.3	117.6	27.4	M6
441	[0.50]	[2.07]	[1.25]	[0.63]	[2.80]	[6.03]	[1.77]	M8
441-2	12.7	52.5	31.8	15.9	71.2	153.1	44.9	M8

### Features:

- Tempered spring steel jaws provide exceptional jaw depth

### Applications:

- Assembly
- Gluing, soldering

### Also Available:

See page MC-ACC-1 for accessories

431



### Technical Information | Holding Capacities | Dimensions

Model	Max. Holding Capacity	Weight	(K5) Maximum Clamping Thickness	Spindle (Supplied)
431	400 N [100 lbf]	0,14kg [0.31 lb]	6,8 [0.27]	424208-M

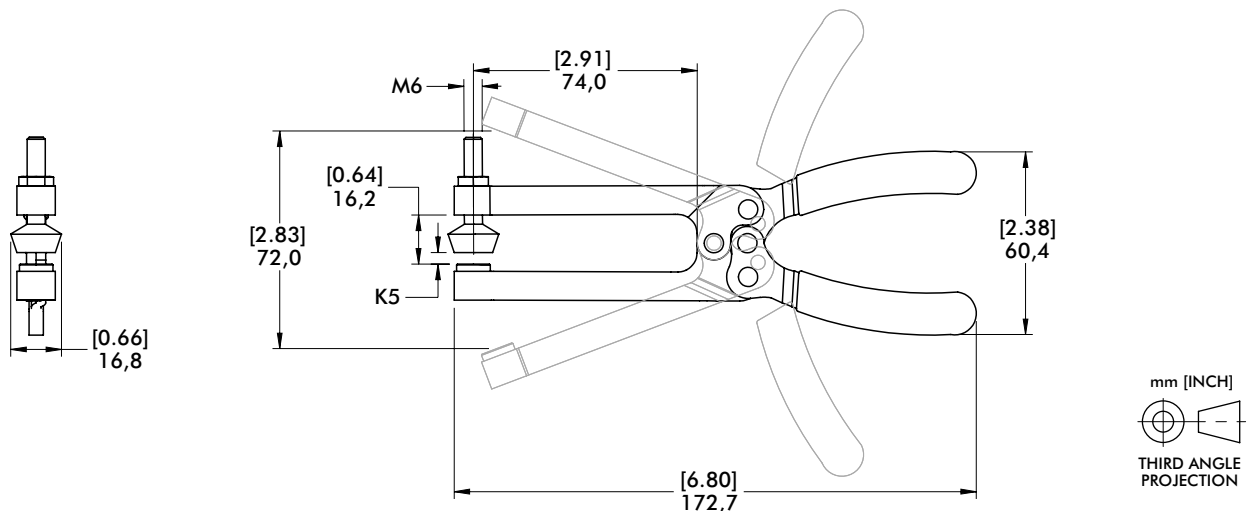

# 460, 480 SERIES

## Squeeze Action Plier Clamps | Product Overview

### Features:

- Drop forged alloy steel components for exceptional strength
- Two way trigger release allows for fast and easy opening of clamp

### Applications:

- Assembly
- Welding

### Also Available:

See page MC-ACC-1 for accessories

462



462-2

With Two Adjustable Spindles



463



482



484



486



## Technical Information | Holding Capacities

Model	Max. Holding Capacity	Weight	Maximum Clamping Thickness	Spindle (Supplied)
462	3110 N [700 lbf]	0,51kg [1.13lb]	29,5 [1.16]	468206-M
462-2			30,5 [1.20]	(2X) 491203-M
463			54,2 [2.13]	468206-M 210203-M
482	5340 N [1200 lbf]	0,79kg [1.75lb]	29,5 [1.16]	468206-M
484			76,5 [3.01]	468206-M 210203-M
486			138,4 [5.45]	(2X) 240203-M



# 460, 480 SERIES

## Squeeze Action Plier Clamps | Dimensions

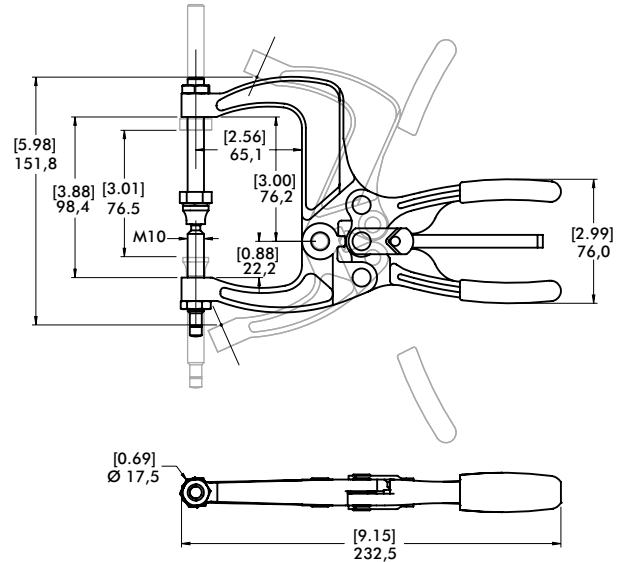
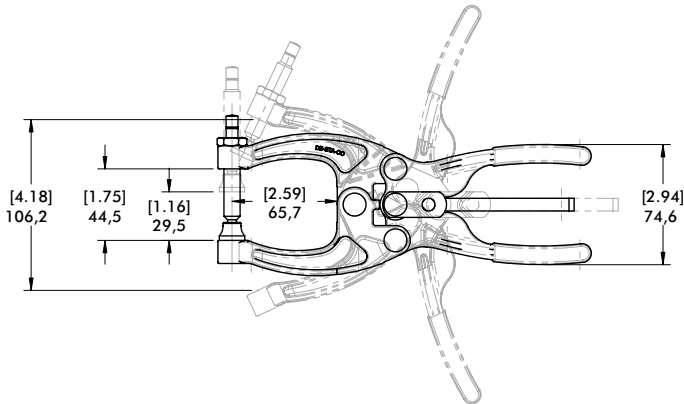
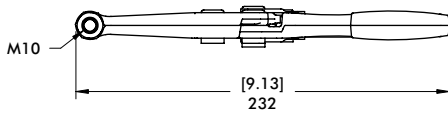
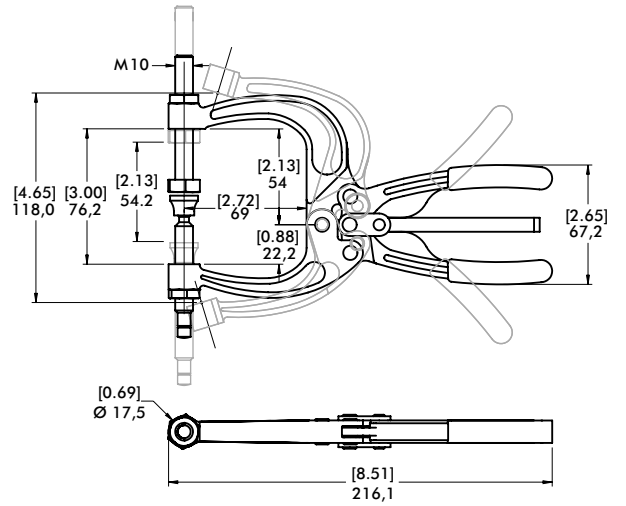
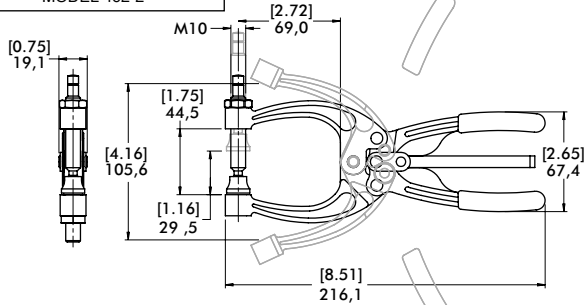
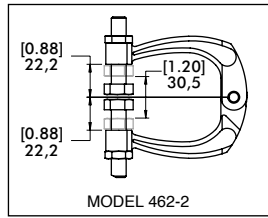

MODEL 482 AS SHOWN

MODEL 484 AS SHOWN

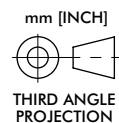
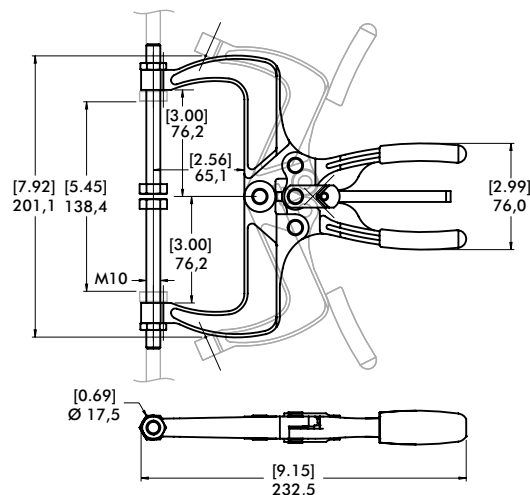

# MANUAL CLAMPING ACCESSORIES

## Manual Clamping Accessory Overview



Flat-Tip Bonded  
Neoprene Spindle – Inch



Large Diameter Padded  
Swivel Foot Spindle – Inch



Neoprene Caps



Special Neoprene  
Caps



Metric Flat-Tip Bonded  
Neoprene Spindle – Metric



Swivel Foot  
Spindle



Polyurethane Caps



Cone-Tip  
Polyurethane Caps



Round Bonded  
Neoprene Spindle – Metric



Hex Head  
Spindle



Bolt Retainers



Flanged Washers



Cone-Tip Bonded  
Neoprene Spindle – Metric



Plunger-matic  
Assemblies



Adapters and  
Extensions

### Flat-Tip Bonded Neoprene Spindle – Inch

- Black neoprene, hardness: 70-80 Shore A
- Temperature Range: -20°C to 100°C [-22°F to 212°F]
- Oil resistant, LABS (silicone) free
- Includes jam nuts
- Stainless steel versions available upon request

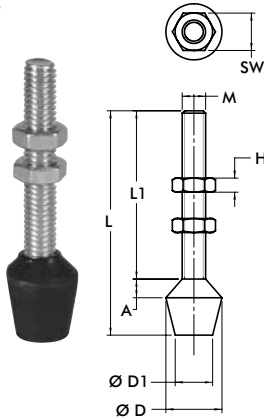

Part No.	M	L	L1	SW	H	A	ØD	ØD1
102208	#8-32	[1.25] 31,8	[0.94] 23,8	[0.34] 8,7	[0.13] 3,2	[0.06] 1,6	[0.56] 14,3	[0.44] 11,1
105208		[1.00] 25,4	[0.69] 17,4					
201208	#10-32	[1.38] 35,1	[1.01] 25,5	[0.38] 9,5	[0.16] 4	[0.13] 3,2	[0.63] 16	[0.47] 12
202208		[1.63] 41,4	[1.08] 27,4					
215208	1/4-20	2.13 54,1	[1.58] 40,1	[0.44] 11,1	[0.16] 4	[0.13] 3,3	[0.66] 16,8	[0.50] 12,7
424208		[1.50] 38,1	[1.12] 28,5					
431208		[1.00] 25,4	[0.62] 15,8					
225208	5/16-18	[2.25] 57,2	[1.54] 39,1	[0.50] 12,7	[0.19] 4,8	[0.20] 5	[0.83] 21	[0.55] 14
507208		[3.00] 76,2	[2.29] 58,2					
240208	3/8-16	[3.25] 82,6	[2.31] 58,5	[0.56] 14,3	[0.22] 5,6	[0.20] 5	[1.02] 26	[0.79] 20
527208		[3.50] 88,9	[2.50] 63,5					
235208		[5.75] 146,1	[4.77] 121,1					
247208	1/2-13	[3.87] 98,3	[2.73] 69,3	[0.75] 19,1	[0.31] 7,9	[0.28] 7	[1.18] 30	[0.95] 24
267208	5/8-11	[5.00] 127	[3.63] 92,1	[0.94] 23,8	[0.38] 9,5	[0.38] 9,5	[1.38] 35,1	[1.00] 25,4

### Flat-Tip Bonded Neoprene Spindle – Metric

- Red neoprene, hardness: 80-85 Shore A
- Temperature Range: -20°C to 100°C [-22°F to 212°F]
- Oil resistant, LABS (silicone) free
- Includes jam nuts

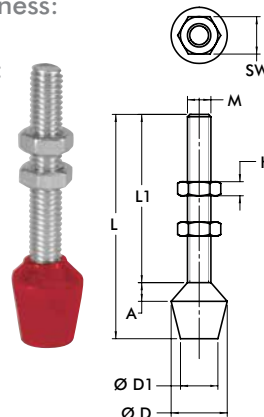

Part No.	M	L	L1	SW	H	A	ØD	ØD1
431208-M	M6	[1.00] 25,4	[0.6] 15,8	[0.39] 10	[0.13] 3,2	[0.13] 3,3	[0.66] 16,8	[0.66] 16,8
424208-M		[1.63] 41,3	[1.25] 31,7					
202208-M		[1.73] 44	[1.18] 30					
215208-M	M8	[2.13] 54	[1.57] 40	[0.51] 13	[0.16] 4	[0.20] 5	[0.83] 21	[0.55] 14
225208-M		[2.09] 53	[1.38] 35					
2007208-M		[2.48] 63	[1.77] 45					
507208-M	M10	[3.27] 83	[2.56] 65	[0.67] 17	[0.20] 5	[0.28] 7	[1.02] 26	[0.78] 20
240208-M		[3.11] 79	[2.17] 55					
235208-M		[4.72] 120	[3.74] 95					
247208-M	M12	[4.02] 102	[2.87] 73	[0.75] 19	[0.24] 6	[0.28] 7	[1.18] 30	[0.94] 24

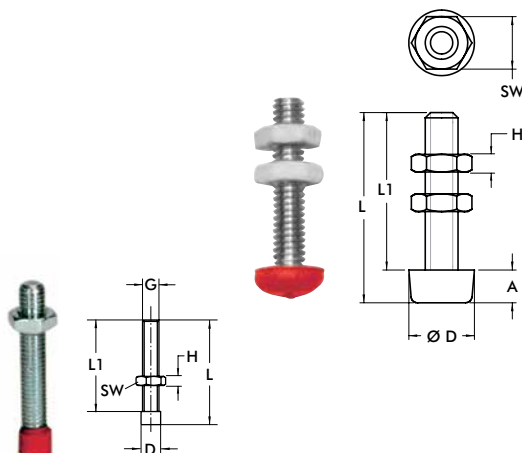

Part No.	M	L	L1	SW	H	A	ØD
205208-M	M4	[0.87] 22	[0.79] 20	[0.28] 7	[0.09] 2,2	[0.11] 2,8	[0.32] 8
201208-M		[1.26] 32	[1.18] 30				
305208-M	M5	[1.14] 29	[0.98] 25	[0.32] 8	[0.11] 2,7	[0.20] 5	[0.39] 10
213208-M		[1.34] 34	[1.18] 30				
2013208-M		[1.54] 39	[1.38] 35				
307208-M	M8	[1.69] 43	[1.38] 35	[0.51] 13	[0.16] 4	[0.35] 9	[0.75] 19

Part No.	D	L	L1	ØG
213208-M-L <sup>Ⓢ</sup>	[0.24] 6	[1.34] 34	[1.18] 30	M5

<sup>Ⓢ</sup> Item is available upon request.

# SPINDLES

## Manual Clamping Accessories | Technical Information | Dimensions

### Cone-Tip Bonded Neoprene Spindle – Inch

- Black neoprene, hardness: 70-80 Shore A
- Temperature Range: -20°C to 100°C [-22°F to 212°F]
- Oil resistant, LABS (silicone) free
- Includes jam nuts

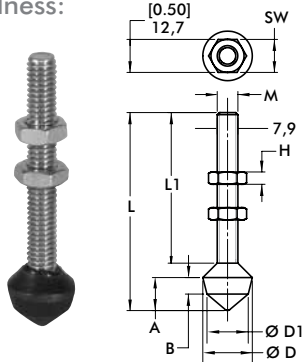

Part No.	M	L	L1	SW	H	A	B	ØD	ØD1
<b>305208</b>	#10-32	[1.50] 38,1	[1.00] 25,4	[0.38] 9,5	[0.13] 3,3	[0.38] 9,5	[0.19] 4,8	[0.56] 14,2	[0.44] 11,2
<b>213208</b>	1/4-20	[2.25] 57,2	[1.56] 39,6	[0.44] 11,2	[0.16] 4,0				
<b>509208</b>	5/16-18	[3.00] 76,2	[2.28] 57,9	[0.50] 12,7	[0.19] 4,8	[0.50] 12,7	[0.25] 6,4	[0.75] 19,1	[0.63] 16
<b>519208</b>		[5.50] 139,7	[4.75] 120,7						
<b>210208</b>	3/8-16	[3.50] 88,9	[2.50] 63,5	[0.56] 14,2	[0.23] 5,8	[0.75] 19,1	[0.41] 10,4	[0.88] 22,4	[0.75] 19,1

### Large Diameter Padded Swivel Foot Spindle-Inch

- White neoprene, hardness: 70-80 Shore A
- Temperature Range: -40°C to 105°C [-40°F to 220°F]
- Non-marking neoprene
- Includes jam nuts

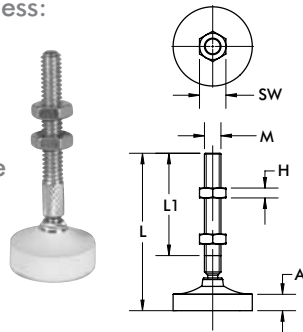

Part No.	M	L	L1	SW	H	A	ØD	Swivel Angle
<b>207209</b>	1/4-20	[2.56] 65	[1.56] 39,6	[0.44] 11,2	[0.16] 4		[1.00] 25,4	14°
<b>507209</b>	5/16-18	[2.98] 75,7	[1.94] 49,3	[0.50] 12,7	[0.19] 4,8	[0.31] 8	[1.50] 38,1	24°
<b>210209</b>	3/8-16	[3.56] 90,4	[2.44] 62	[0.56] 14,2	[0.23] 5,8		[2.00] 50,8	26°

### Plunger-matic Assemblies

- For use with Straight Line Action clamps
- Internal compression spring compensates for variations in material thickness
- Zinc plated
- Includes jam nut

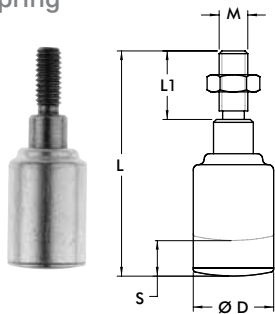

Part No.	M	L	L1	ØD	Max. Compression S	Spring Constant [lb./in] N/mm	Max. Force [lb.] N
<b>905</b>	5/16-18	[2.50] 63,5	[0.75] 19,1	[0.88] 22,2	[0.19] 4,8	[750]	[135]
<b>905-M</b>	M8					131	600
<b>920</b>	3/8-16	[3.63] 92,2	[1.13] 28,6		[0.38] [9,6]	[822]	[308]
<b>920-M</b>	M10				144	1370	

### Swivel Foot Spindle

- Includes jam nuts

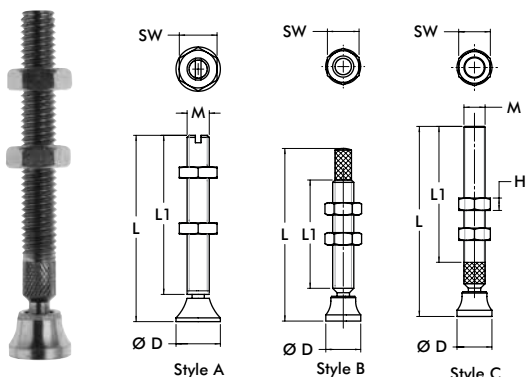

Part No.	M	Style	L	L1	SW	H	ØD	Swivel Angle
<b>207206-M</b>	M6	A	[2.44] 62	[2.13] 54	[0.39] 10	[0.13] 3,2	[0.47] 12	30°
<b>507206-M</b>	M8		[2.87] 73	[2.46] 62,5	[0.51] 13	[0.16] 4	[0.63] 16	
<b>468206-M</b>	M10	B	[3.06] 77,8	[2.00] 50,8	[0.67] 17	[0.20] 5	[0.79] 20	24°
<b>210206-M</b>		A	[3.31] 84	[2.80] 71				
<b>250206-M</b>	M12	A	[4.72] 120	[4.13] 105	[0.75] 19	[0.24] 6	[0.98] 25	30°
<b>207206</b>	1/4-20	C	[2.38] 60,5	[1.56] 39,6	[0.44] 11,2	[0.16] 4	[0.50] 12,7	14°
<b>507206</b>	5/16-18		[2.75] 69,9	[1.94] 49,3	[0.50] 12,7	[0.19] 4,8	[0.56] 14,2	
<b>468206</b>	3/8-16	B	[3.06] 77,7	[1.92] 48,8	[0.56] 14,2	[0.23] 5,8	[0.63] 16	24°
<b>210206</b>		C	[3.38] 85,9	[2.41] 61,2				
<b>250206</b>	1/2-13	C	[4.63] 117,6	[3.44] 87,4	[0.75] 19,1	[0.31] 7,9	[1.00] 25,4	24°

### Hex Head Spindle – Stainless Steel

- Includes Plain hexagonal head
- Includes Fully threaded
- Includes Stainless steel, type 303
- Includes jam nuts

Part No.	M	L	L1	SW	H	Part No.	M	L	L1	SW	H
<b>205943-M</b>	M4	[0.89] 22	[0.79] 20	[0.28] 7	[0.09] 2,2	<b>205943</b>	#8-32	[0.86] 21,8	[0.75] 19,1	[0.25] 6,4	[0.13] 3,2
<b>201943-M</b>	M5	[1,32] 33,5	[1.18] 30	[0.31] 8	[0.11] 2,7	<b>201943</b>	#10-32	[1,37] 34,8	[1,37] 34,8	[0.31] 8	
<b>202943-M</b>	M6	[1.73] 42,4	[1.57] 40	[0.39] 10	[0.13] 3,2	<b>202943</b>	1/4-20	[1.67] 42,4	[1.50] 38,1	[0.44] 11,1	[0.16] 4
<b>207943-M</b>	M8	[2.77] 70,3	[2.56] 65	[0.51] 13	[0.16] 4	<b>207943</b>	5/16-18	[2.72] 69	[2.50] 63,5	[0.50] 12,7	[0.19] 4,8
<b>237943-M</b>	M10	[3.00] 76,4	[2.76] 70	[0.67] 17	[0.20] 5	<b>237943</b>	3/8-16	[2.75] 69,9	[2.56] 65,2	[0.56] 14,2	[0.22] 5,6
<b>245943-M</b>	M12	[2.87] 73	[2.56] 65	[0.75] 19	[0.24] 6	<b>245943</b>	1/2-13	[2.72] 69	[2.38] 60,5	[0.75] 19,1	[0.31] 8

### Hex Head Spindle

- Plain hexagonal head
- Fully threaded
- Zinc plated
- Includes jam nuts

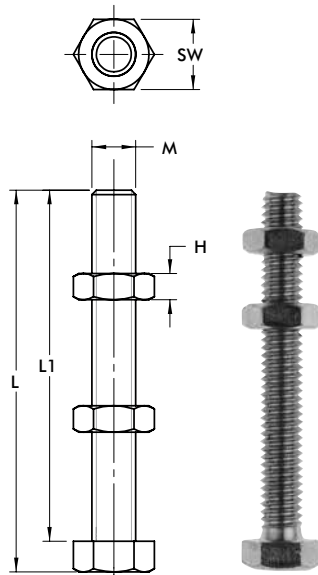

Part No.	M	L	L1	SW	H	Part No.	M	L	L1	SW	H
<b>205203-M</b>	M6	[1.93] 49	[1.77] 45	[0.39] 10	[0.13] 3,2	<b>205203</b>	1/4-20	[1.92] 48,8	[1.75] 44,5	[0.44] 11,2	[0.16] 4
<b>461203-M</b>	M8	[1.20] 30,5	[0.98] 25	[0.51] 13	[0.16] 4	<b>202203</b>		[3.17] 80,5	[3.00] 76,2		
<b>207203-M</b>		[2.97] 75,5	[2.76] 70			<b>461203</b>		[1.22] 31	[1.00] 25,4		
<b>491203-M</b>		[1.85] 47	[1.57] 40			<b>441203</b>	5/16-18	[1.97] 50	[1.75] 44,5	[0.50] 12,7	[0.19] 4,8
<b>210203-M</b>	M10	[3.03] 77	[2.76] 70	[0.67] 17	[0.20] 5	<b>207203</b>		[2.72] 69,1	[2.50] 63,5		
<b>240203-M</b>		[4.21] 107	[3.94] 100			<b>491203</b>		[1.75] 44,5	[1.50] 38,1		
<b>220203-M</b>	M12	[3.46] 88	[3.15] 80	[0.75] 19	[0.24] 6	<b>210203</b>	3/8-16	[3.00] 76,2	[2.75] 69,9	[0.56] 14,2	[0.23] 5,8
<b>267203-M</b>	M16	[5.12] 130	[4.72] 120	[0.94] 24	[0.28] 7	<b>240203</b>		[4.25] 108	[4.00] 101,6		
<b>105203*</b>	#8-32	[0.86] 21,8	[0.75] 19,1	[0.25] 6,4	[0.13] 3,3	<b>527203</b>		[5.25] 133,4	[5.00] 127		
<b>305203</b>	#10-32	[1.12] 28,4	[1.00] 25,4	[0.31] 8		<b>325203</b>	1/2-13	[2.84] 72,1	[2.50] 63,5	[0.75] 19,1	[0.31] 7,9
						<b>220203</b>		[3.34] 84,8	[3.00] 76,2		
						<b>250203</b>	5/8-11	[4.42] 111,6	[4.00] 101,6	[0.38] 9,5	[0.38] 9,5

\*Material: nylon

# SPINDLE CAPS

## Manual Clamping Accessories | Technical Information | Dimensions

### Neoprene Caps

- Slip on head of hex-head spindles
- Hardness: 60-70 Shore A
- Temperature range:  
-40°C to 105°C [-40°F to 220°F]

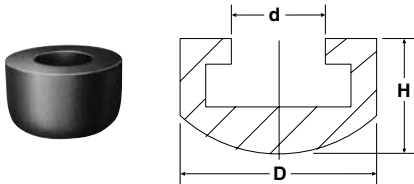

Part No.	D	d	H	For Spindle Diameter
215119	[0.63] 16	[0.25] 6,35	[0.44] 11,1	M6 or 1/4
225119	[0.75] 19,1	[0.31] 8	[0.50] 12,7	M8 or 5/16
235119	[0.88] 22,3	[0.38] 9,7	[0.53] 13,5	3/8

### Special Neoprene Caps

- Slip on threaded spindle rod
- Hardness: 60-70 Shore A
- Temperature range:  
-40°C to 105°C [-40°F to 220°F]

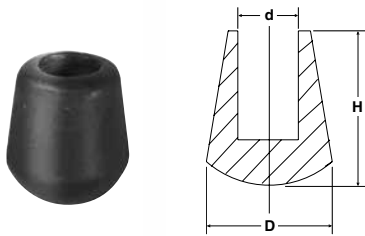

Part No.	D	d	H	For Spindle Diameter
424107	[0.44] 11,1	[0.22] 5,6	[0.44] 11,1	M6 or 1/4
235110	[0.72] 18,3	[0.34] 8,6	[0.88] 22,3	M10 or 3/8

### Polyurethane Caps

- Flat tip, internally threaded
- Hardness: 80 Shore A
- Temperature range:  
-70°C to 95°C [-90°F to 200°F]

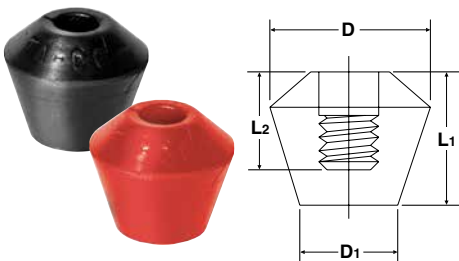

Part No.	D	D1	L1	L2	For Spindle Diameter	Color
215219					1/4-20	Black
215219-M	[0.79] 20	[0.50] 12,7	[0.69] 17,5	[0.50] 12,7	M6 x 1.0	Red
225219					5/16-18	Black
225219-M					M8 x 1.25	Red
235219	[0.81] 20,5	[0.63] 16	[0.88] 22,3	[0.63] 16	3/8-16	Black
235219-M					M10 x 1.5	Red

### Polyurethane Caps – Cone-tip

- Cone tip, internally threaded
- Hardness: 80 Shore A
- Temperature range:  
-70°C to 95°C [-90°F to 200°F]

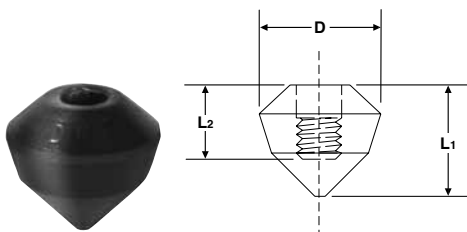

Part No.	D	L1	L2	For Spindle Diameter
215319				1/4
225319	[0.81] 20,5	[0.75] 19,1	[0.50] 12,7	5/16
235319		[0.94] 23,9	[0.63] 16	3/8

# BOLT RETAINERS, WASHERS

Manual Clamping Accessories | Technical Information | Dimensions

## Bolt Retainers –

- For use with clamps featuring U-bar and open bar clamping arms

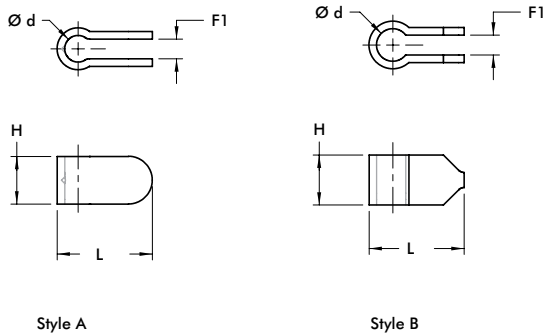

Part No.	L	H	Ød	F1	For Spindle Diameter	Style
207105	[1.23] 31,3	[0.63] 16	[0.34] 8,7	[0.28] 7,1	M8 or 5/16	A
207105-M	[1.26] 32		[0.32] 8,2	[0.24] 6		B
210114	[1.50] 38,1	[0.75] 19,1	[0.53] 13,5	[0.31] 8	M10 or 3/8	A
210114-M	[1.49] 38	[0.78] 20	[0.51] 13			B
247110	[1.63] 41,4	[0.88] 22,3	[0.56] 14,2	[0.38] 9,7	M12 or 1/2	A
247110-M	[1.61] 41	[0.87] 22,2	[0.57] 14,4			B
250121	[1.88] 47,8	[1.00] 25,4	[0.64] 16,3		M12 or 1/2	A
2002115-E	[0.97] 24,6	[0.50] 12,7	[0.26] 6,6	[0.23] 5,8	M6 or 1/4	B
2007115-E	[1.26] 32	[0.75] 19,1	[0.34] 8,6		M8 or 5/16	
2010115-E	[1.58] 40,1	[1.13] 28,7	[0.41] 10,4	[0.32] 8,1	M10 or 3/8	

## Flanged Washers –

- For use with clamps featuring U-bar and open bar clamping arms
- Zinc plated

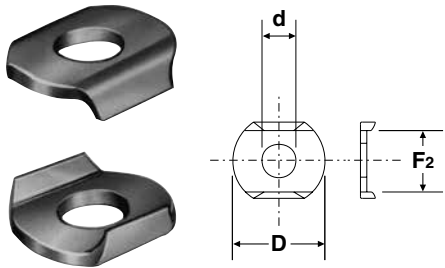

Part No.	ØD	Ød	F2	For Spindle Diameter
105106	[0.44] 11,2	[0.17] 4,3	[0.33] 8,3	M4 or #8
102111	[0.56] 14,2	[0.20] 5,1	[0.38] 9,6	M5 or #10
215105	[0.69] 17,5	[0.26] 6,7	[0.50] 12,7	M6 or 1/4
507107	[0.88] 22,4	[0.33] 8,4	[0.59] 15	M8 or 5/16
235106	[1.00] 25,4	[0.41] 10,5	[0.75] 19,1	M10 or 3/8
247109	[1.26] 32	[0.53] 13,5	[0.91] 23,2	M12 or 1/2
267102	[1.44] 36,5	[0.66] 16,8	[1.03] 26,2	M16 or 5/8

## Flanged Washers-Stainless Steel

- For use with clamps featuring U-bar and open bar clamping arms

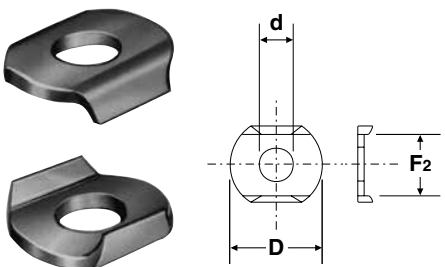

Part No.	ØD	Ød	F2	For Spindle Diameter
105906	[0.44] 11,2	[0.17] 4,3	[0.33] 8,3	M4 or #8
102911	[0.56] 14,2	[0.20] 5,1	[0.38] 9,6	M5 or #10
215905	[0.69] 17,5	[0.26] 6,7	[0.50] 12,7	M6 or 1/4
507907	[0.88] 22,4	[0.33] 8,4	[0.60] 15,2	M8 or 5/16
235906	[1.00] 25,4	[0.41] 10,5	[0.75] 19,1	M10 or 3/8
247909	[1.26] 32	[0.53] 13,5	[0.91] 23,2	M12 or 1/2
267902	[1.44] 36,6	[0.66] 16,8	[1.03] 26,2	M16 or 3/8

# ADAPTERS & EXTENSIONS

## Manual Clamping Accessories | Product Overview

### Features:

- Provides flexible adjustment of length and height
- Mounts to manual clamp models that feature open clamping arms
- Lightweight aluminum

### Application Areas:

- Checking fixtures
- Areas requiring multiple clamping points

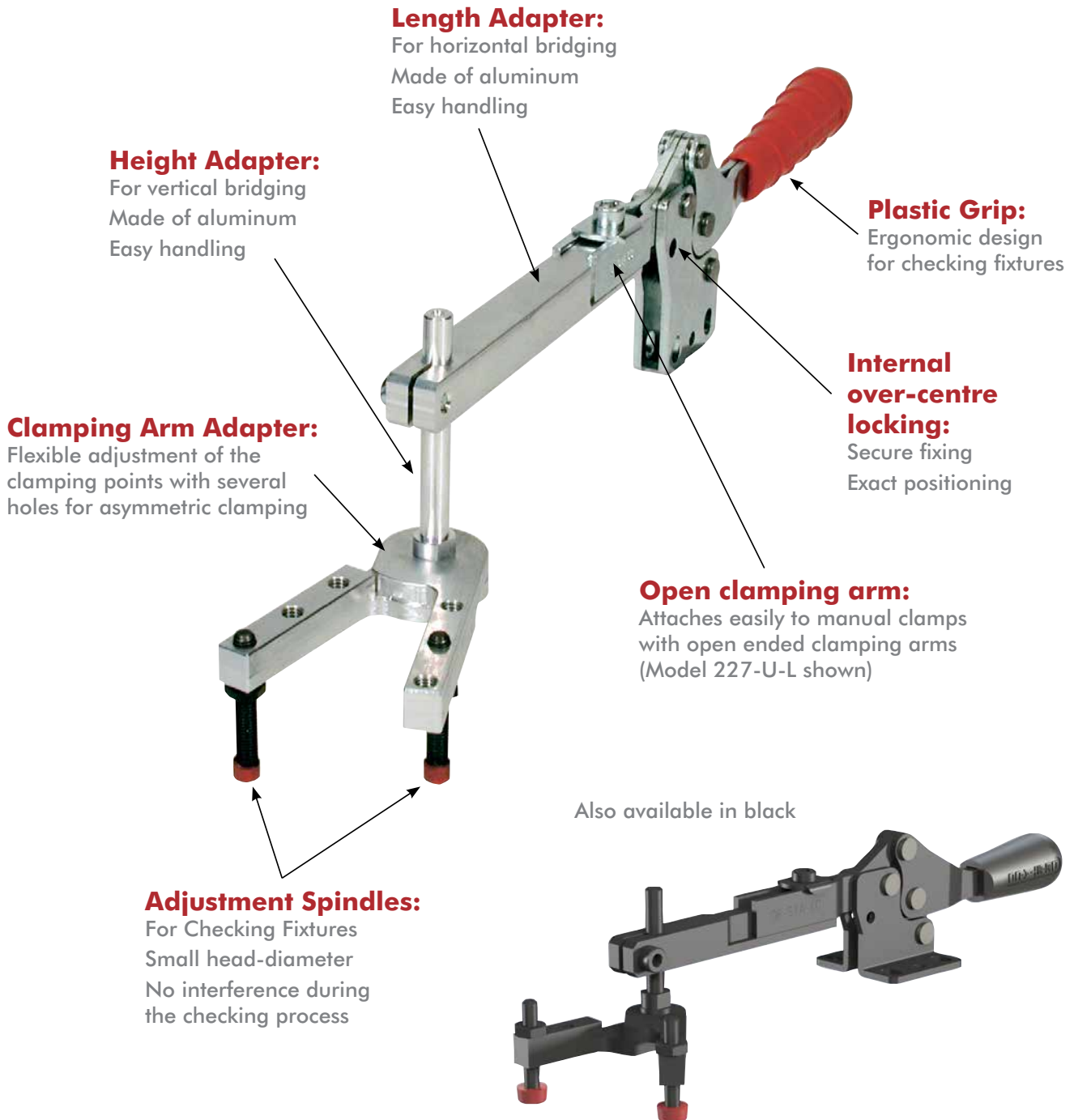



# ADAPTERS & EXTENSIONS

## Manual Clamping Accessories | Dimensions

### Length Adapter

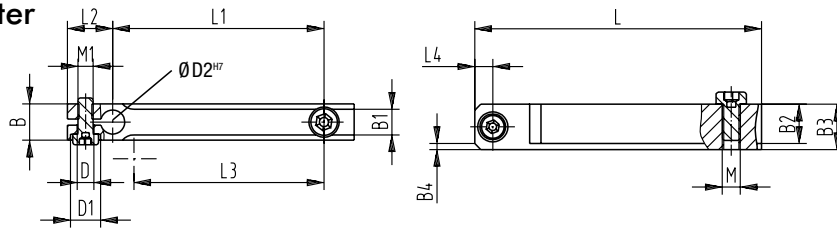

Model no.	Length adapter	B	B1 +0, -1	B2	B3	B4	DØ	D1 Ø	D2 <sup>H7</sup>	L	L1 ±0,2	L2	L3	L4	M	M1
<b>213-U-L / 213-UB-L</b>	<b>L-213-1-01</b> ⓘ	[0.39]	[0.22]	[0.31]	[0.39]	2x 45°	[0.22]	--		[1.97] 50	[1.18] 30	[0.47]	[0.79]	[0.20]	M4	M5
<b>2013-U / 2013-UB</b>	<b>L-213-1-02</b> ⓘ	10	5,5	8	10		5,5			[3.54] 90	[2.76] 70	12	20	5		
<b>2013-UR / 2013-UBR</b>																
<b>202-U-L / 202-UB-L</b>	<b>L-217-1-01</b> ⓘ								[0.24] 6	[2.17] 55	[1.18] 30		[1.30] 33			
<b>217-U-L / 217-UB-L</b>																
<b>2002-U-L / 2002-UB-L</b>	<b>L-217-1-02</b> ⓘ		[0.26] 6,5	[0.35] 9	[0.47] 12	2x 45°	[0.22] 5,5			[3.74] 95	[2.76] 70				M5	M5
<b>2017-U / 2017-UB</b>	<b>L-217-1-03</b> ⓘ									[5.31] 135	[4.33] 110		[1.89] 48			
<b>2017-UR / 2017-UBR</b>																
<b>207-U-L / 207-UB-L</b>	<b>L-227-1-01</b> ⓘ	[0.47] 12						[0.39] 10		[2.17] 55	[1.18] 30	[0.59] 15	[1.30] 33	[0.24] 6		
<b>227-U-L / 227-UB-L</b>	<b>L-227-1-02</b> ⓘ									[3.74] 95	[2.76] 70					
<b>2007-U-LS / 2007-U-LS</b>	<b>L-227-1-03</b> ⓘ		[0.33] 8,5	[0.51] 13	[0.59] 15	2x 45°	[0.22] 5,5		[0.31] 8	[5.31] 135	[4.33] 110		[2.87] 73		M6	M5
<b>2027-U / 2027-UB</b>	<b>L-227-1-04</b> ⓘ									[6.89] 175	[5.91] 150					
<b>2027-UR / 2027-UBR</b>																

ⓘ Available upon request.

Also available in Black. Add **-BLK** to part number.

### Height Adapter

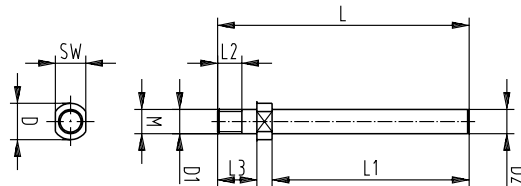

Model no.	Height adapter	DØ	D1 Ø f7	D2 f7	L	L1	L2	L3	SW	M
<b>213-U-L / 213-UB-L</b>	<b>L-213-2-01</b> ⓘ		[0.20] 5	[0.24] 6	[2.05] 52	[1.38] 35				M5
<b>2013-U / 2013-UB</b>	<b>L-213-2-02</b> ⓘ				[3.23] 82	[2.56] 65				
<b>2013-UR / 2013-UBR</b>										
<b>202-U-L / 202-UB-L</b>		[0.39] 10			[2.05] 52	[1.38] 35		[0.47] 12	[0.31] 8	M6
<b>217-U-L / 217-UB-L</b>	<b>L-217-2-01</b> ⓘ		[0.24] 6	[0.24] 6						
<b>2002-U-LS / 2002-UB-LS</b>	<b>L-217-2-02</b> ⓘ				[3.23] 82	[2.56] 65	[0.31] 8			
<b>2017-U / 2017-UB</b>										
<b>2017-UR / 2017-UBR</b>										
<b>207-U-L / 207-UB-L</b>					[2.09] 53	[1.38] 35		[0.51] 13	[0.39] 10	M8
<b>227-U-L / 227-UB-L</b>	<b>L-227-2-01</b> ⓘ	[0.31] 8	[0.31] 8	[0.31] 88						
<b>2007-U-LS / 2007-U-LS</b>	<b>L-227-2-02</b> ⓘ				[3.23] 82	[2.56] 65				
<b>2027-U / 2027-UB</b>										
<b>2027-UR / 2027-UBR</b>										

ⓘ Available upon request.

Also available in Black. Add **-BLK** to part number.

# ADAPTERS & EXTENSIONS

## Manual Clamping Accessories | Dimensions

### Clamping Arm Adapter

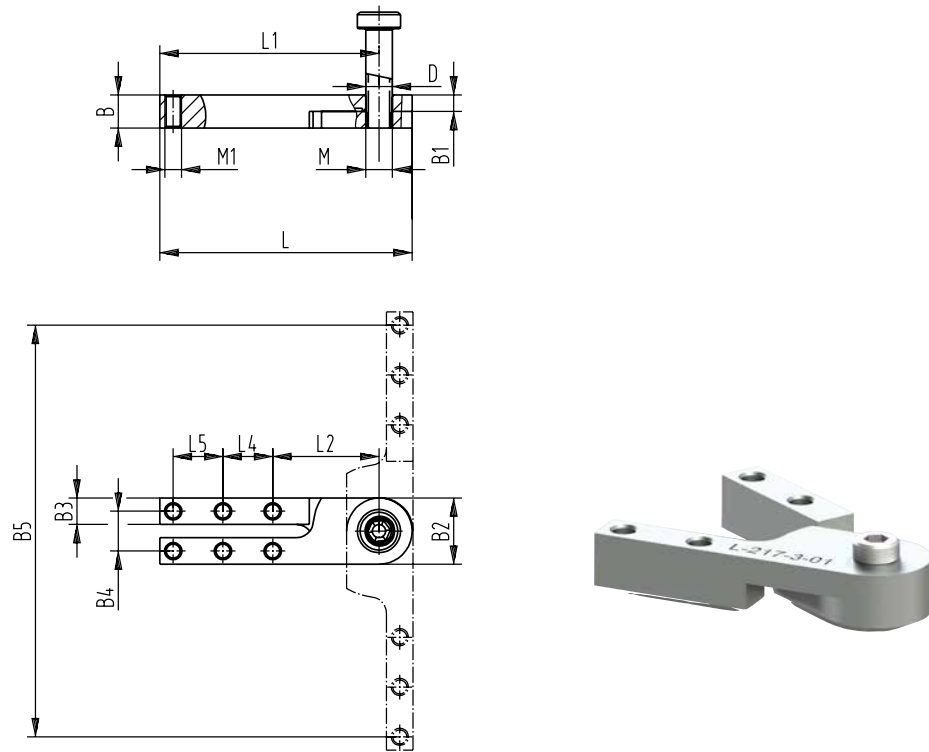

Model no.	Clamping arm adapter	B	B1	B2	B3	B4	B5	D <sub>H7</sub>	L	L1	L2	L4	L5	L6	M	M1
213-U-L / 213-UB-L 2013-U / 2013-UB 2013-UR / 2013-UBR	L-213-3-01 ⓘ							[0.20] 5					-		M5	M5
202-U-L / 202-UB-L 217-U-L / 217-UB-L 2002-U-LS / 2002-UB-LS 2017-U / 2017-UB 2017-UR / 2017-UBR	L-217-3-01 ⓘ	[0.39] 10	[0.20] 5	[0.79] 20	[0.31] 8	[0.47] 12	[3.70] 94	[0.24] 6	[2.40] 61	[2.01] 51	[1.26] 32	[0.59] 15		[0.39] 10	M6	M5
207-U-L / 207-UB-L 227-U-L / 227-UB-L 2007-U-LS / 2007-UB-LS 2027-U / 2027-UB 2027-UR / 2027-UBR	L-227-3-01 ⓘ						4.88 124	[0.31] 8	[2.99] 76	[2.60] 66			[0.59] 15		M8	M5

ⓘ Available upon request.

Also available in Black. Add **-BLK** to part number.

# ADAPTERS & EXTENSIONS

## Manual Clamping Accessories | Dimensions

### Arm Extension:

- Easily cut to length
- Drilled & tapped for spindle attachment

Note: adding arm extension will reduce the clamp's holding capacity. Refer to Technical Appendix for details

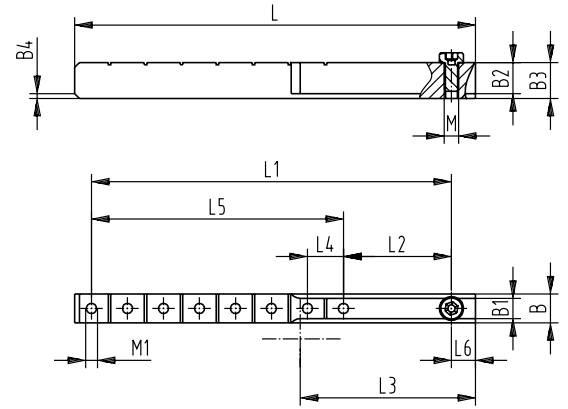
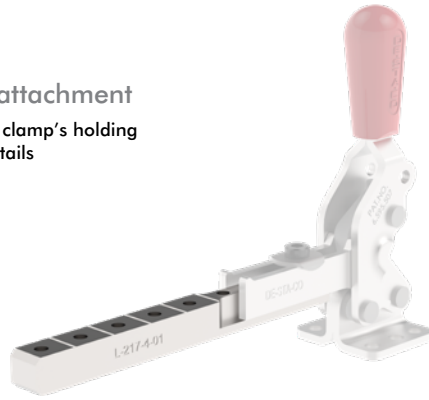

Model no.	Extension link	B	B1 +0, -1	B2	B3	B4	L ±0,2	L1	L2	L3	L4	L5	L6	M	M1
<b>213-U-L / 213-UB-L</b> <b>2013-U / 2013-UB</b> <b>2013-UR / 2013-UBR</b>	<b>L-213-4-01</b> ⓘ	[0.39] 10	[0.22] 5,5	[0.31] 8	[0.39] 10	2x 45°	[3.35] 85	[2.76] 70	[0.87] 22	[0.79] 20	[0.47] 12	[1.89] 48	[0.31] 8	M4	M5
<b>202-U-L / 202-UB-L</b> <b>217-U-L / 217-UB-L</b> <b>2002-U-LS / 2002-UB-LS</b> <b>2017-U / 2017-UB</b> <b>2017-UR / 2017-UBR</b>	<b>L-217-4-01</b> ⓘ		[0.26] 6,5	[0.35] 9	[0.47] 12	2x 45°	[5.00] 127	[4.33] 110	[1.38] 35	[1.89] 48		[2.95] 75	[0.39] 10	M5	M5
<b>207-U-L / 207-UB-L</b> <b>227-U-L / 227-UB-L</b> <b>2007-U-LS / 2007-UB-LS</b> <b>2027-U / 2027-UB</b> <b>2027-UR / 2027-UBR</b>	<b>L-227-4-01</b> ⓘ	[0.47] 12									[0.59] 15				
			[0.33] 8,5	[0.51] 13	[0.59] 15	2x 45°	[6.57] 167	[5.91] 150	[1.77] 45	[2.87] 73		[4.13] 105	[0.39] 10	M6	M5

ⓘ Available upon request. Also available in Black. Add **-BLK** to part number.

### Cross Arm Set

- 1 x cross arm
- 2 x adjustment spindles with neoprene thrust pads vulcanized, resin-free, inc.
- 2 x fastening nuts
- 4 x flange washers
- 1 x screw incl. 1 x fastening nut, self-locking

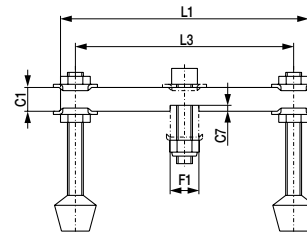

Model no.	For Models with U Arms	C1	C7	F	F1	L1	L3	Adjustable Spindles
<b>207426-Q</b>	<b>207, 225, 227</b>	[0.47] 12	[0.12] 3	[0.31] 35	[0.57] 14,5	[4.92] 125	[4.33] 110	507208-M
<b>210440-Q</b>	<b>210, 235, 237</b>	[0.63] 16	[0.16] 4	[0.43] 11	[0.75] 19	[5.87] 149	[5.12] 130	240208-M

# 812 SERIES

## Pneumatic Toggle Clamps | Product Overview

### Features:

- Smallest of the pneumatic hold down series
- Pneumatic version of Model 201-U

### Applications:

- Assembly
- Welding

### Also Available:

See page MC-ACC-1 for spindle accessories

See page MC-PSC-38 for sensing options

High temperature version available upon request as Model 812-**U-HT**

### 812-U



## Technical Information | Holding Capacities

Model	Maximum Holding Capacity		Maximum Exerting Force @ 5bar [72PSI]		Weight	Bore Size	Air Consumption† dm³ [ft³]	Port Size	Accessories (Supplied)	
	Inner	Outer	Inner	Outer					Spindle Accessory	Flanged Washers
<b>812-U</b>	[100 lbf] 440 N	[55 lbf] 245 N	[136 lbf] 613 N	[92 lbf] 413 N	[0.46lb] 0,21kg	[0.75] 19,1	[0.003] 0,09	M5	305208-M	102111

†Per double stroke at 5bar [72PSI]

**Max. Operating Temp:** -23°C to 74°C [-10°F to 165°F]

**Optional Sensors:** 810156, 810158

**Replacement Clamp Assembly:** 812-U-LC

**Replacement Cylinder Assembly:** 812CYL

In no case should the inlet pressure be high enough to create an exerting force that exceeds the clamp's holding capacity. See Technical Appendix Section for details.

# 812 SERIES

## Pneumatic Toggle Clamps | Dimensions

812-U

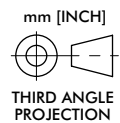
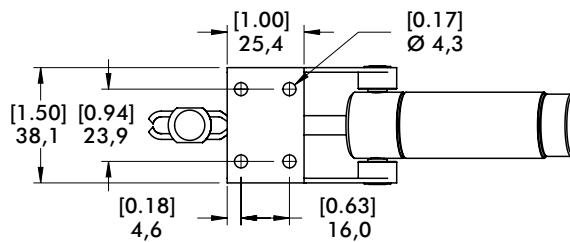
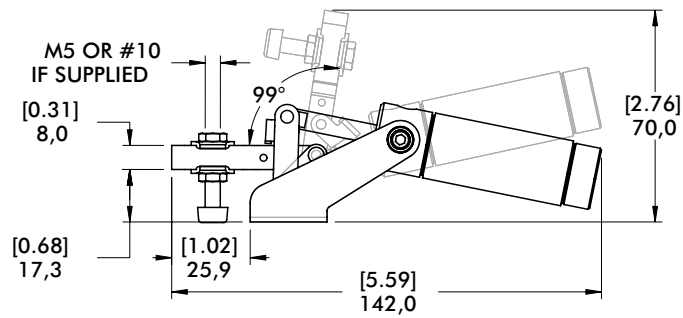
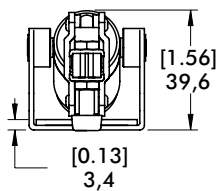
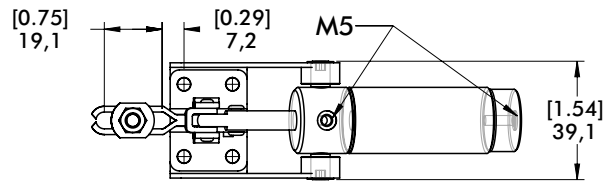

**Note:**

Model 812-U requires either 810156 or 810158 sensors. Two (2) sensors are required if detecting both open and closed positions. These sensors use 810156-1 (included with sensors) band clamp to mount the sensor to the cylinder wall.



# 802 SERIES

## Pneumatic Toggle Clamps | Product Overview

### Features:

- Pneumatic version of Model 202-U
- Sensor ready for T-slot or round sensors

### Applications:

- Assembly
- Welding

### Also Available:

See page MC-ACC-1 for spindle accessories

See page MC-PSC-38 for sensing options

High temperature version available upon request, add **-HT** to model number. Example: 802-U-**HT**

802-U  
802-UE



## Technical Information | Holding Capacities

Model	Maximum Holding Capacity		Max. Exerting Force @ 5bar [72PSI]		Weight	Bore Size	Air Consumption† dm <sup>3</sup> [ft <sup>3</sup> ]	Port Size	Accessories (Supplied)	
	Inner	Outer	Inner	Outer					Spindle Accessory	Flanged Washers
802-U	[200 lbf] 890 N	[110 lbf] 490 N	[200 lbf] 890 N	[110 lbf] 490 N	[1.52 lb] 0,69 kg	[0.79] 20	[0.0006] 0,02	1/8 NPT G-1/8	202208-M	215105
802-UE										

†Per double stroke at 5bar [72PSI]

**Max Cylinder Pressure:** 10bar [145psig]\*

**Max Operating Temp:** -10°C to 90°C [-14°F to 194°F]

**Replacement Seal Kit:** 802550-20-1-00

**Replacement Clamp Assembly:** 802-U-LC

**Replacement Cylinder Assembly:** 802CYL

\*In no case should the inlet pressure be high enough to create an exerting force that exceeds the clamp's holding capacity. See Technical Appendix for details.

### Sensor Accessories

Round Reed Switch with Quick Disconnect

T-slot Reed Switch with Quick Disconnect

Quick Disconnect 2M Extension Cable

Quick Disconnect 5M Extension Cable

### Item Number

810169

8EA-109-1

CABL-010

CABL-013

See Pneumatic Accessories section for more options

# 802 SERIES

## Pneumatic Toggle Clamps | Dimensions

802-U  
802-UE

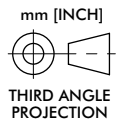
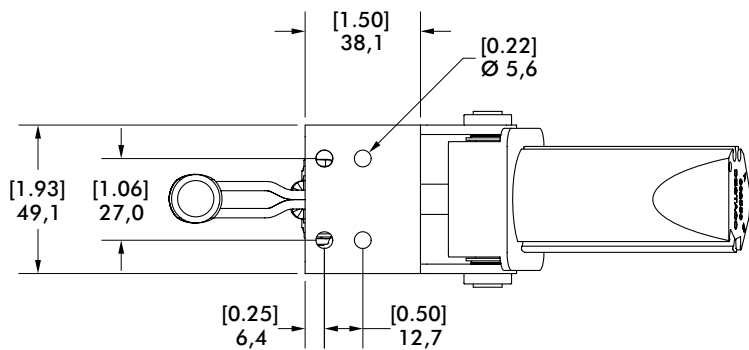
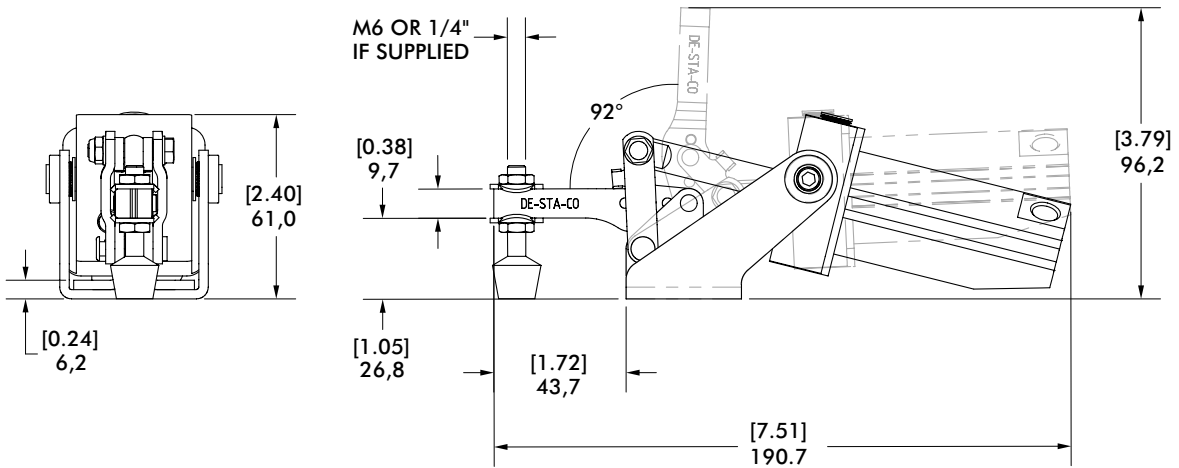
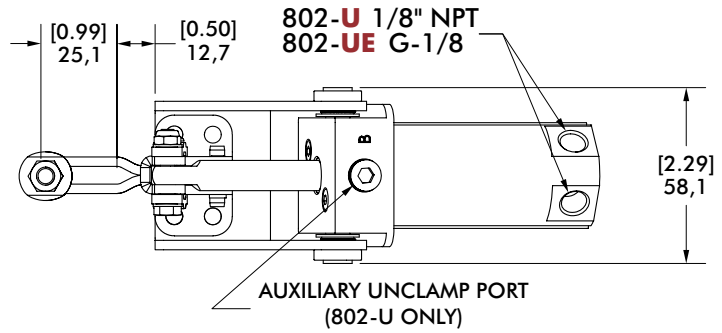

# 807 SERIES

## Pneumatic Toggle Clamps | Product Overview

### Features:

- Pneumatic version of Series 207 manual clamps
- Sensor ready for round or T-slot sensors.
- Built-in flow restriction eliminates need for external flow controls

### Applications:

- Assembly
- Welding

### Also Available:

See page MC-ACC-1 for spindle accessories

See page MC-PSC-38 for sensing options

High temperature version available upon request, add **-HT** to model number. Example: 807-U-**HT**

807-U  
807-UE



807-S  
807-SE



## Technical Information | Holding Capacities

Model	Maximum Holding Capacity		Maximum Exerting Force @ 5bar [72PSI]		Weight	Bore Size	Air Consumption† dm³ [ft³]	Port Size	Accessories (Supplied)		
	Inner	Outer	Inner	Outer					Spindle Accessory	Flanged Washers	Bolt Retainer
807-U	[375 lbf]	[275 lbf]	[576 lbf]	[297 lbf]	[1.66lb]	[1.26]	[0.015]	1/8 NPT	--	507107	--
807-UE	1670 N	1220 N	2573 N	1327 N				G-1/8	2007208-M		
807-S	[500 lbf]	[260 lbf]	[540 lbf]	[180 lbf]	0,75kg	32	0,42	1/8 NPT	--	--	207105
807-SE	2220 N	1160 N	2412 N	804 N				G-1/8			

†Per double stroke at 5bar [72PSI]

**Max Cylinder Pressure:** 10bar [145psig]\*

**Max Operating Temp:** -10°C to 90°C [-14°F to 194°F]

**Replacement Seal Kit:** 802450-32-1-00

**Replacement Clamp Assembly:** 807-U-LC, 807-S-LC

**Replacement Cylinder Assembly:** 807CYL

\*In no case should the inlet pressure be high enough to create an exerting force that exceeds the clamp's holding capacity. See Technical Appendix for details.

### Sensor Accessories

	Item Number
Round Reed Switch with Quick Disconnect	810169
T-slot Reed Switch with Quick Disconnect	8EA-109-1
Quick Disconnect 2M Extension Cable	CABL-010
Quick Disconnect 5M Extension Cable	CABL-013

See Pneumatic Accessories section for more options



# 807 SERIES

## Pneumatic Toggle Clamps | Dimensions

807-U  
807-UE

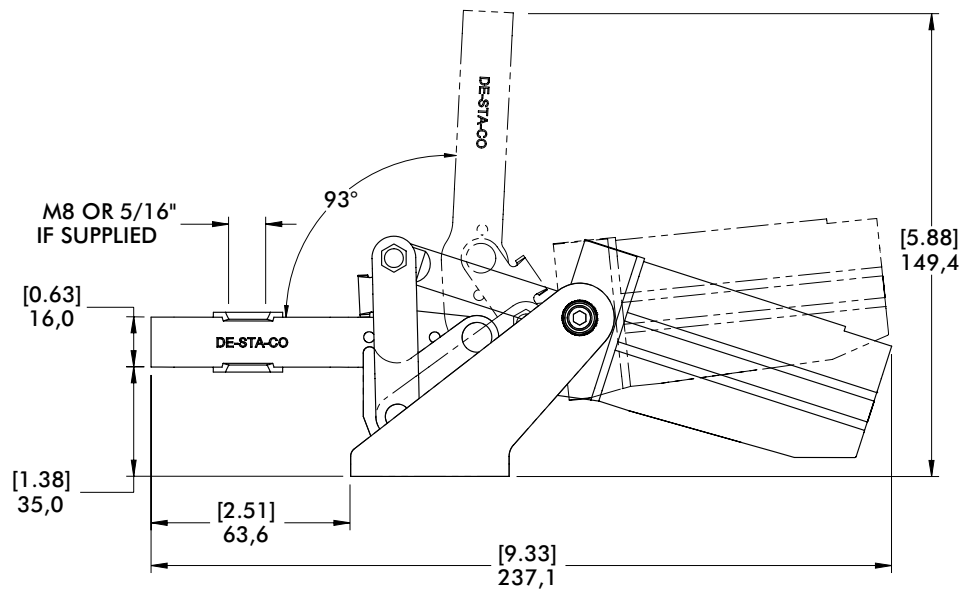
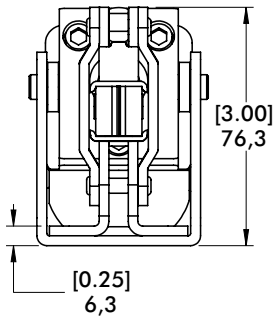
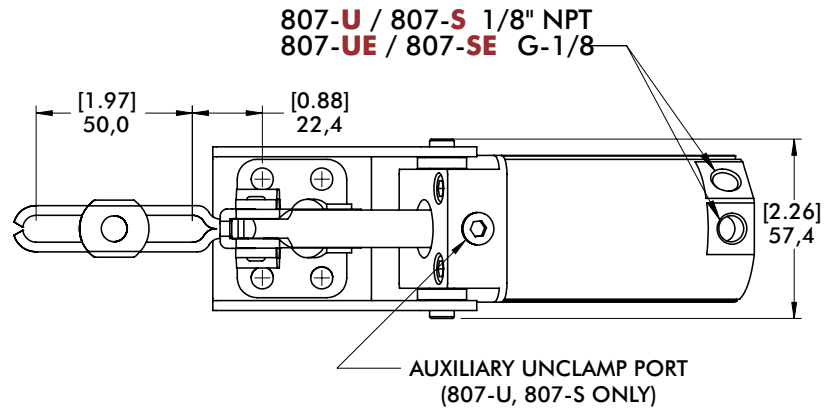

807-S  
807-SE

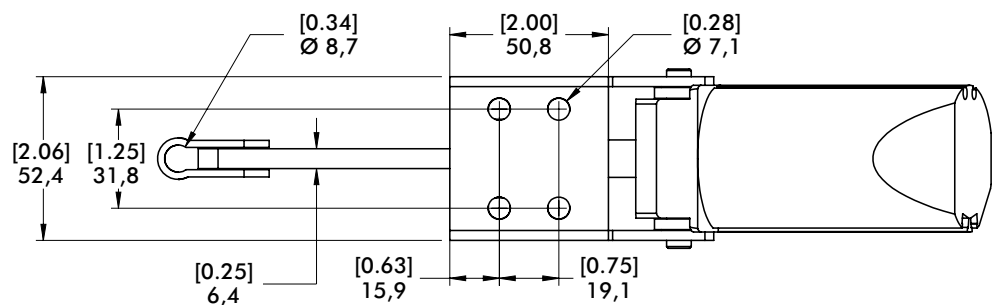

mm [INCH]

THIRD ANGLE PROJECTION

# 810 SERIES

## Pneumatic Toggle Clamps | Product Overview

### Features:

- Pneumatic version of Series 210 manual clamps
- Sensor ready for round or T-slot style sensors
- Built-in flow restriction eliminates need for external flow controls

### Applications:

- Assembly
- Welding

### Also Available:

See page MC-ACC-1 for spindle accessories  
See page MC-PSC-38 for sensing options

810-U  
810-UE



810-S  
810-SE



## Technical Information | Holding Capacities

Model	Maximum Holding Capacity		Maximum Exerting Force @ 5bar [72PSI]		Weight	Bore Size	Air Consumption dm <sup>3</sup> [ft <sup>3</sup> ]	Port Size	Accessories (Supplied)		
	Inner	Outer	Inner	Outer					Spindle Accessory	Flanged Washers	Bolt Retainer
810-U	[600 lbf]	[290 lbf]	[856 lbf]					1/8 NPT	--		
810-UE	2670 N	1290 N	3834 N	[407 lbf]	[4.07lb]	[1.57]	[0.029]	G-1/8	240208-M	235106	--
810-S	[750 lbf]	[500 lbf]	[702 lbf]					1/8 NPT	--	--	210114
810-SE	3340 N	2220 N	3143 N					G-1/8	--	--	

†Per double stroke at 5bar [72PSI]

**Max Cylinder Pressure:** 10bar [145psig]\*

**Max Operating Temp:** -10°C to 90°C [-14°F to 194°F]

**Replacement Seal Kit:** 810450-40-1-00

**Replacement Clamp Assembly:** 810-U-LC, 810-S-LC

**Replacement Cylinder Assembly:** 810CYL

\*In no case should the inlet pressure be high enough to create an exerting force that exceeds the clamp's holding capacity.

### Sensor Accessories

	Item Number
Round Reed Switch with Quick Disconnect	810169
T-slot Reed Switch with Quick Disconnect	8EA-109-1
Quick Disconnect 2M Extension Cable	CABL-010
Quick Disconnect 5M Extension Cable	CABL-013

See Pneumatic Accessories section for more options

# 810 SERIES

## Pneumatic Toggle Clamps | Dimensions

**810-U**  
**810-UE**

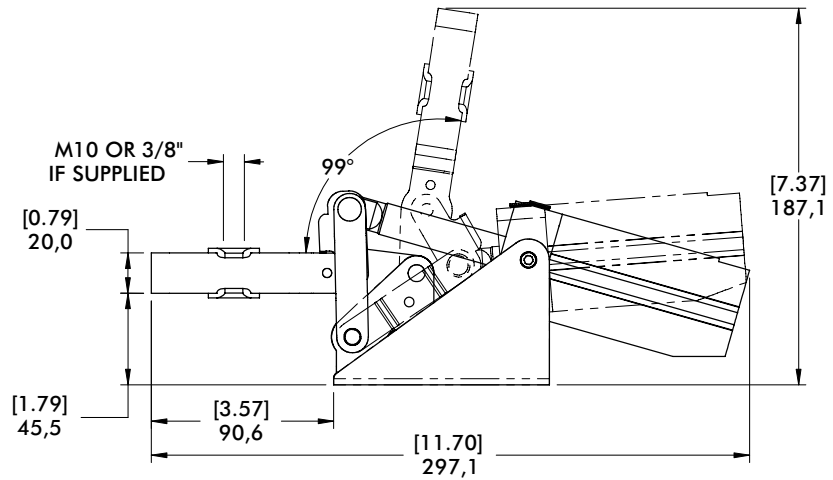
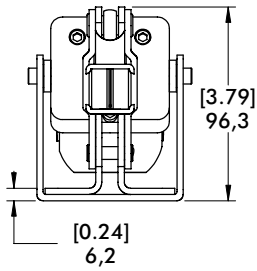
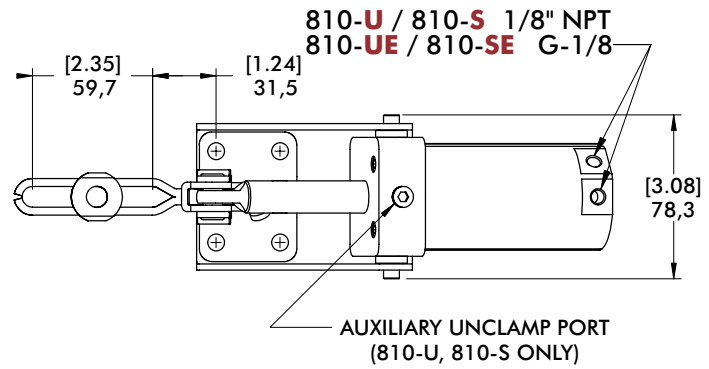

**810-S**  
**810-SE**

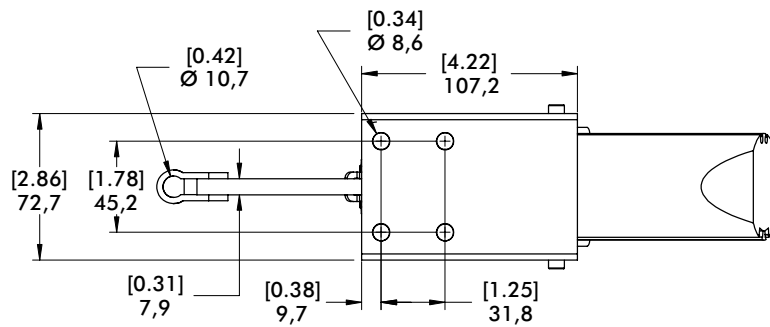

mm [INCH]  
THIRD ANGLE PROJECTION

# 846 SERIES

## Pneumatic Toggle Clamps | Product Overview

### Features:

- Similar in size to 807 but with higher holding capacity
- Large, solid clamping arm is easily modified to suit application requirements
- Sensor ready for round or T-slot style sensors

### Applications:

- Assembly
- Welding

### Also Available:

See page MC-PSC-38 for sensing options

846 ⓘ



## Technical Information | Holding Capacities

Model	Maximum Holding Capacity		Max. Exerting Force @ 5bar [72PSI]		Weight	Bore Size	Air Consumption† dm <sup>3</sup> [ft <sup>3</sup> ]	Port Size
	Inner	Outer	Inner	Outer				
846 ⓘ	[750 lbf] 3340 N	[520 lbf] 2310 N	[786 lbf] 3520 N	[491 lbf] 2200 N	[4.18lb] 1,90kg	[1.57] 40	[0.029] 0,83	1/8 NPT

ⓘ This item is available upon request. †Per double stroke at 5bar [72PSI]

**Max Cylinder Pressure:** 10bar [145psig]\*

**Max Operating Temp:** -10°C to 90°C [-14°F to 194°F]

**Replacement Seal Kit:** 810450-40-1-00

**Replacement Clamp Assembly:** 846-LC

**Replacement Cylinder Assembly:** 846CYL

\*In no case should the inlet pressure be high enough to create an exerting force that exceeds the clamp's holding capacity. See Technical Appendix Section for details.

### Sensor Accessories

	Item Number
Round Reed Switch with Quick Disconnect	810169
T-slot Reed Switch with Quick Disconnect	8EA-109-1
Quick Disconnect 2M Extension Cable	CABL-010
Quick Disconnect 5M Extension Cable	CABL-013

See Pneumatic Accessories section for more options

# 846 SERIES

## Pneumatic Toggle Clamps | Dimensions

846 ①

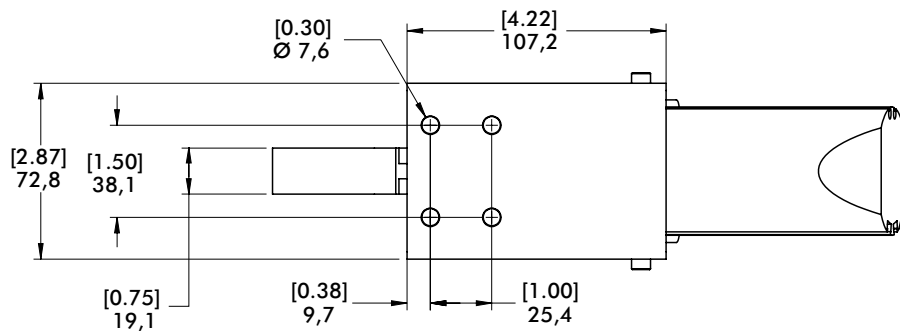
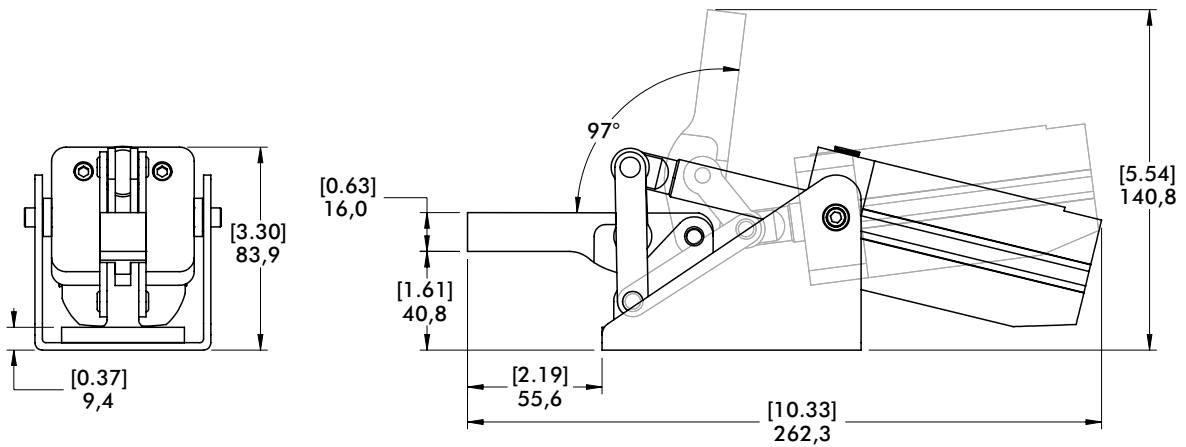
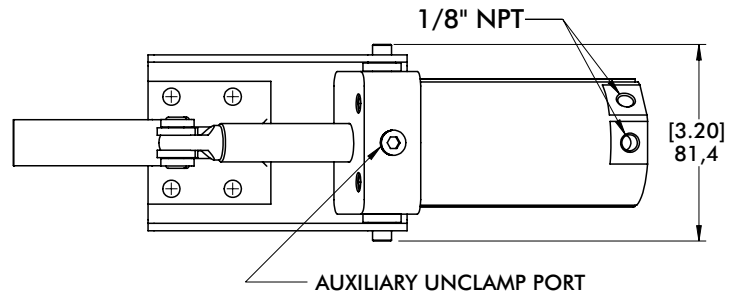

mm [INCH]  
THIRD ANGLE  
PROJECTION

# 847 SERIES

## Pneumatic Toggle Clamps | Product Overview

### Features:

- Pneumatic version of Series 247 manual clamps
- Switch ready for Ø4mm or 6,5mmX5mm sensors
- Built-in flow restriction eliminates need for external flow controls

### Applications:

- Assembly
- Welding

### Also Available:

See page MC-ACC-1 for spindle accessories

See page MC-PSC-38 for sensing options

847-U



847-S



## Technical Information | Holding Capacities

Model	Maximum Holding Capacity		Max. Exerting Force @ 5bar [72PSI]		Accessories (Supplied)						
	Inner	Outer	Inner	Outer	Weight	Bore Size	Air Consumption† dm <sup>3</sup> [ft <sup>3</sup> ]	Port Size	Spindle Accessory	Flanged Washers	Bolt Retainer
847-U	[1000 lbf] 4450 N	[480 lbf] 2135 N	[948 lbf] 4248 N	[450 lbf] 2018 N	[8.93lb] 4,05kg	[1.97] 50	[0.044] 1,25	1/4 NPT	--	247109	--
847-S	[1000 lbf] 4450 N	[650 lbf] 2890 N		[426 lbf] 1912 N				1/4 NPT	--	--	247110

†Per double stroke at 5bar [72PSI]

**Max Cylinder Pressure:** 10bar [145psig]\*

**Max Operating Temp:** -10°C to 90°C [-14°F to 194°F]

**Replacement Seal Kit:** 847450-50-1-00

**Replacement Clamp Assembly:** 847-U-LC, 847-S-LC

**Replacement Cylinder Assembly:** 847CYL

\*In no case should the inlet pressure be high enough to create an exerting force that exceeds the clamp's holding capacity. See Technical Appendix Section for details.

### Sensor Accessories

Round Reed Switch with Quick Disconnect

T-slot Reed Switch with Quick Disconnect

Quick Disconnect 2M Extension Cable

Quick Disconnect 5M Extension Cable

### Item Number

810169

8EA-109-1

CABL-010

CABL-013

See Pneumatic Accessories section for more options

# 847 SERIES

## Pneumatic Toggle Clamps | Dimensions

**847-U**

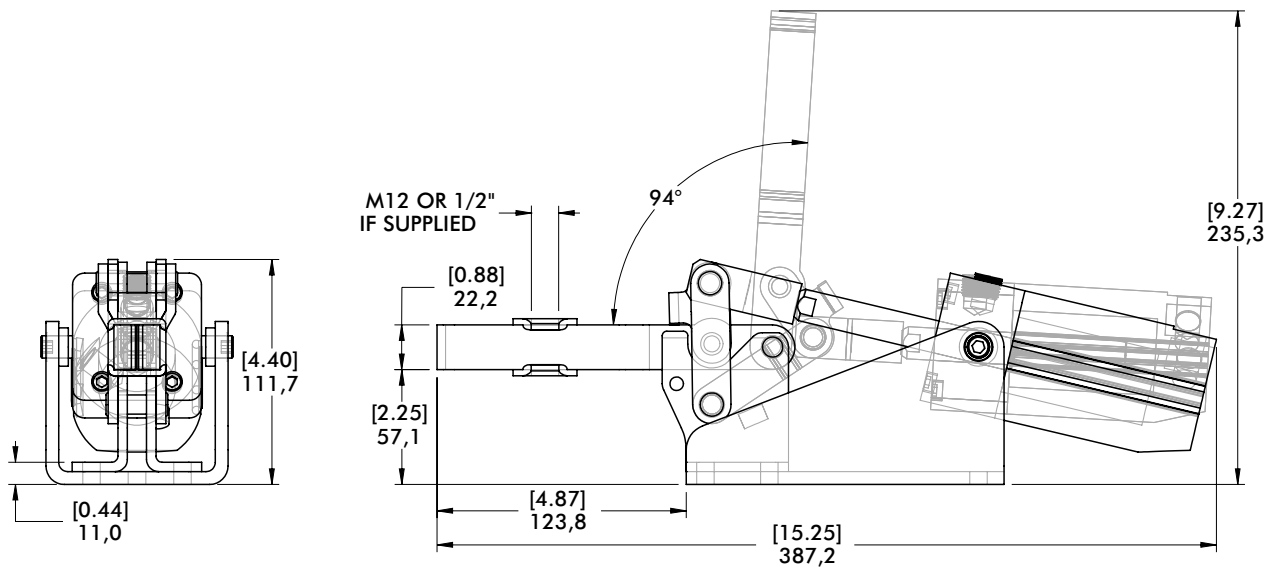
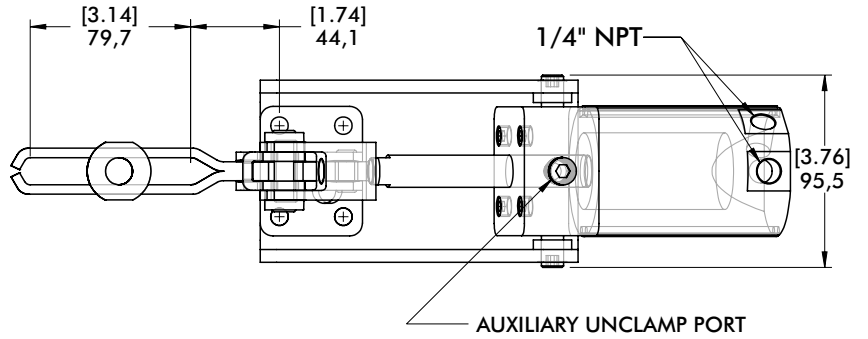

**847-S**

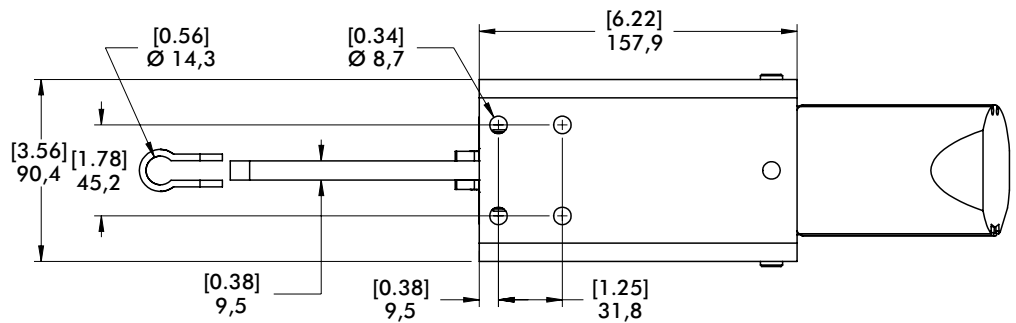

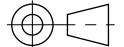
mm [INCH]  
  
 THIRD ANGLE  
 PROJECTION

# 8007 SERIES

## Pneumatic Toggle Clamps | Product Overview

### Features:

- Hardened pins and bushing at all pivot points for long life cycle
- Solid clamping bar may be modified to suit application requirements
- Sensor ready for round or T-slot style sensors

### Applications:

- Assembly
- Welding

### Also Available:

See page MC-PSC-38 for sensing options

8007-E



8007-EHL



8007-EHR



## Technical Information | Holding Capacities

Model	Maximum Holding Capacity		Max. Exerting Force @ 5bar [72PSI]		Weight	Bore Size	Air Consumption† dm <sup>3</sup> [ft <sup>3</sup> ]	Port Size
	Inner	Outer	Inner	Outer				
8007-E					1,6kg [3.53lb]			
8007-EHL	[830 lbf] 3700 N	[405 lbf] 1800 N	[606 lbf] 2700 N	[225 lbf] 1000 N		[1.26] 32	[0.016] 0,44	G-1/8
8007-EHR					1,7kg [3.75lb]			

†Per double stroke at 5bar [72PSI]

**Max Cylinder Pressure:** 10bar [145psig]\*

**Max Operating Temp:** -10°C to 90°C [-14°F to 194°F]

**Replacement Clamp Assembly:** 8007-LC

\*In no case should the inlet pressure be high enough to create an exerting force that exceeds the clamp's holding capacity. See Technical Appendix Section for details.

### Sensor Accessories

Round Reed Switch with Quick Disconnect

T-slot Reed Switch with Quick Disconnect

Quick Disconnect 2M Extension Cable

Quick Disconnect 5M Extension Cable

### Item Number

810169

8EA-109-1

CABL-010

CABL-013

See Pneumatic Accessories section for more options



# 8007 SERIES

## Pneumatic Toggle Clamps | Dimensions



**8007-EHR**

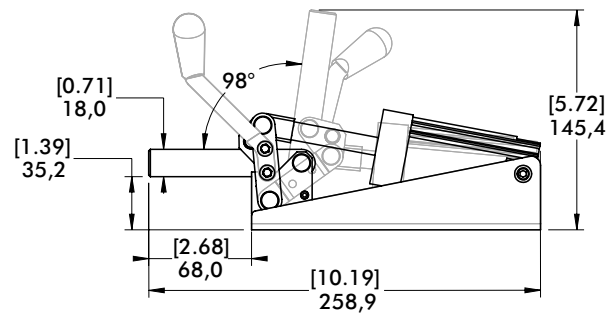
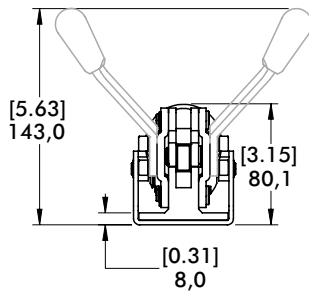
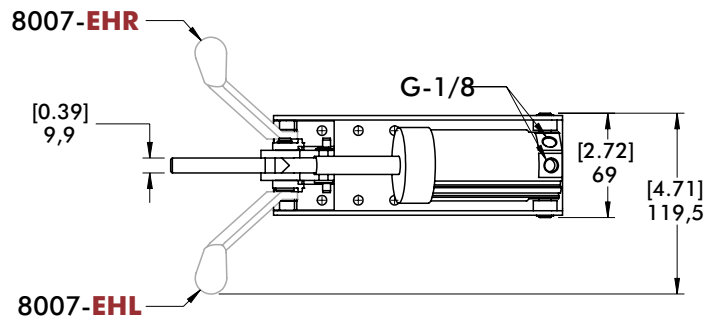

**8007-E**

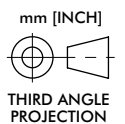
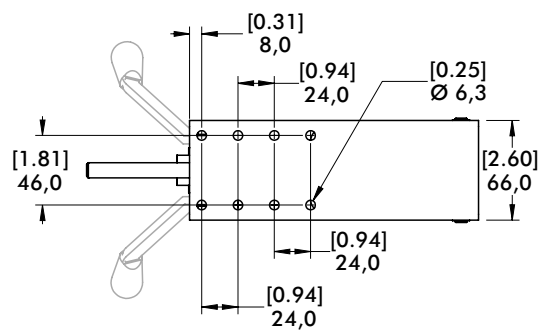

# 858 SERIES

## Pneumatic Toggle Clamps | Product Overview

### Features:

- Hardened pins and bushing at all pivot points for long lifecycle
- Large, solid clamping arm is easily modified to suit application requirements
- Sensor ready for round or T-slot style sensors

### Applications:

- Assembly
- Welding

### Also Available:

See page MC-PSC-38 for sensing options

858  
858-E



## Technical Information | Holding Capacities

Model	Maximum Holding Capacity		Max. Exerting Force @ 5bar [72PSI]		Weight	Bore Size	Air Consumption† dm <sup>3</sup> [ft <sup>3</sup> ]	Port Size
	Inner	Outer	Inner	Outer				
858	[4,000 lbf]	[2,000 lbf]	[1,530 lbf]	[800 lbf]	[16.11lb]	[2.48]	[0.109]	1/4 NPT
858-E	17800 N	8900 N	6857 N	3585 N	7.31kg	63	3,08	G-1/4

†Per double stroke at 5bar [72PSI]

**Max Cylinder Pressure:** 10bar [145psig]\*

**Max Operating Temp:** -10°C to 90°C [-14°F to 194°F]

**Replacement Seal Kit:** 850450-63-1-00

**Replacement Clamp Assembly:** 858-LC

**Replacement Cylinder Assembly:** 858CYL

\*In no case should the inlet pressure be high enough to create an exerting force that exceeds the clamp's holding capacity. See Technical Appendix Section for details.

### Sensor Accessories

Round Reed Switch with Quick Disconnect

T-slot Reed Switch with Quick Disconnect

Quick Disconnect 2M Extension Cable

Quick Disconnect 5M Extension Cable

### Item Number

810169

8EA-109-1

CABL-010

CABL-013

See Pneumatic Accessories section for more options

# 858 SERIES

## Pneumatic Toggle Clamps | Dimensions

858  
858-E

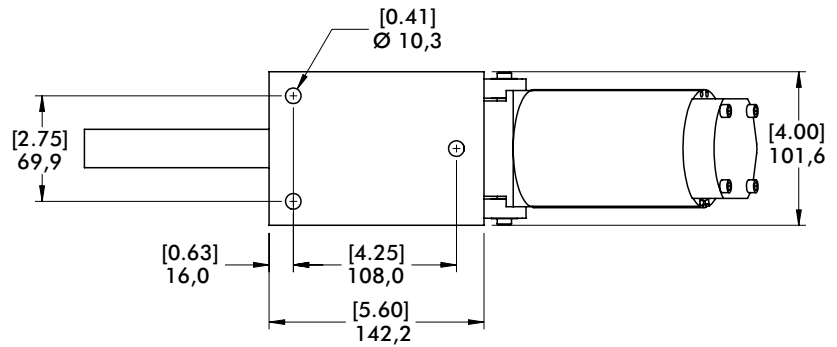
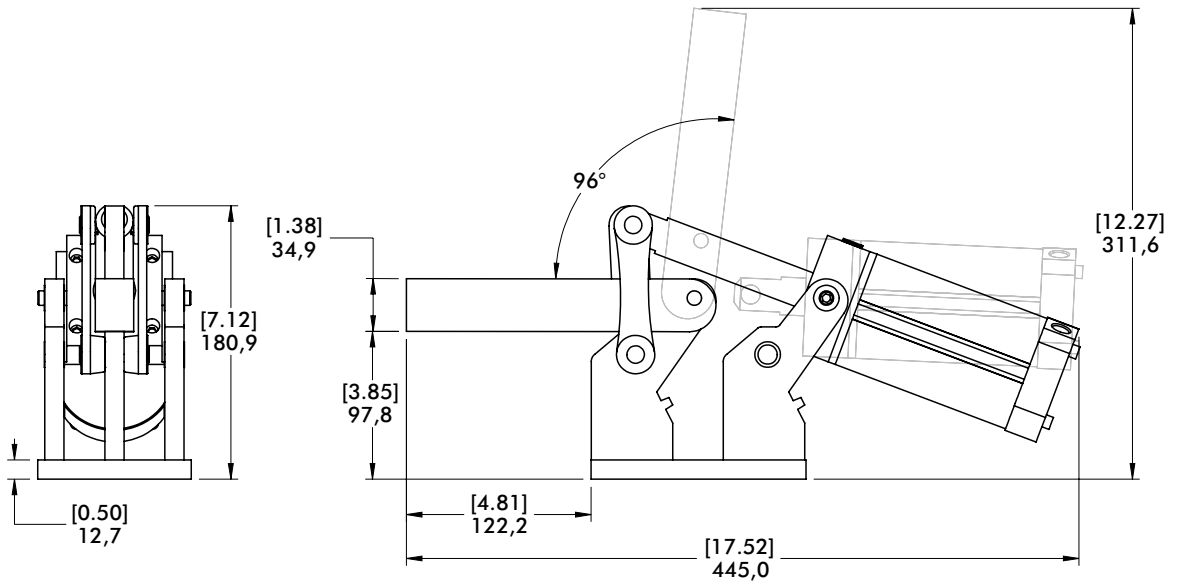
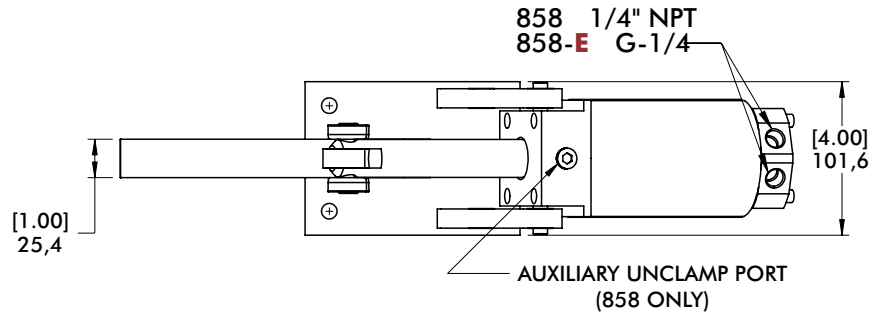

mm [INCH]  
THIRD ANGLE  
PROJECTION

# 8021, 8071 SERIES

## Pneumatic Toggle Clamps | Product Overview

### Features:

- Enclosed clamp for dirty environments such as spot and MIG welding
- Non-pivoting cylinder can be hard-piped into fixtures
- Sensor ready for round or T-slot style sensors

### Applications:

- Assembly
- Welding

### Also Available:

See page MC-ACC-1 for spindle accessories

See page MC-PSC-38 for sensing options

8021 ⓘ  
8021-UE ⓘ



8071  
8071-UE



## Technical Information | Holding Capacities

Model	Maximum Holding Capacity		Max. Exerting Force @ 5bar [72PSI]		Weight	Bore Size	Air Consumption† dm <sup>3</sup> [ft <sup>3</sup> ]	Port Size	Accessories (Supplied)	
	Inner	Outer	Inner	Outer					Spindle Accessory	Flanged Washer
8021 ⓘ	[390 lbf]	[255 lbf]	[169 lbf]	[100 lbf]	[2.30lb]	[1.26]	[0.015]	1/8 NPT	--	8021122
8021-UE ⓘ	1735 N	1135 N	760 N	449 N	1,04kg	32	0,42	G-1/8		
8071	[450 lbf]	[310 lbf]	[496 lbf]	[283 lbf]	[2.80lb]	[1.57]	[0.020]	1/8 NPT	--	507107
8071-UE	2000 N	1380 N	2218 N	1267 N	1,27kg	40	0,58	G-1/8		

ⓘ This item is available upon request. †Per double stroke at 5bar [72PSI]

**Max Cylinder Pressure:** 10bar [145psig]\*

**Max Operating Temp:** -10°C to 90°C [-14°F to 194°F]

**Replacement Seal Kit:** 8021: 802450-32-1-00  
8071: 810450-40-1-00

\*In no case should the inlet pressure be high enough to create an exerting force that exceeds the clamp's holding capacity. See Technical Appendix Section for details.

### Sensor Accessories

	Item Number
Round Reed Switch with Quick Disconnect	810169
T-slot Reed Switch with Quick Disconnect	8EA-109-1
Quick Disconnect 2M Extension Cable	CABL-010
Quick Disconnect 5M Extension Cable	CABL-013

See Pneumatic Accessories section for more options

# 8021, 8071 SERIES

Pneumatic Toggle Clamps | Dimensions | -UE

8021  
8021-UE

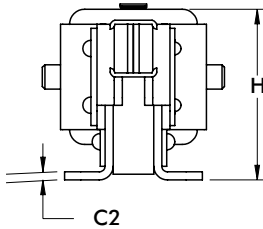

8071  
8071-UE

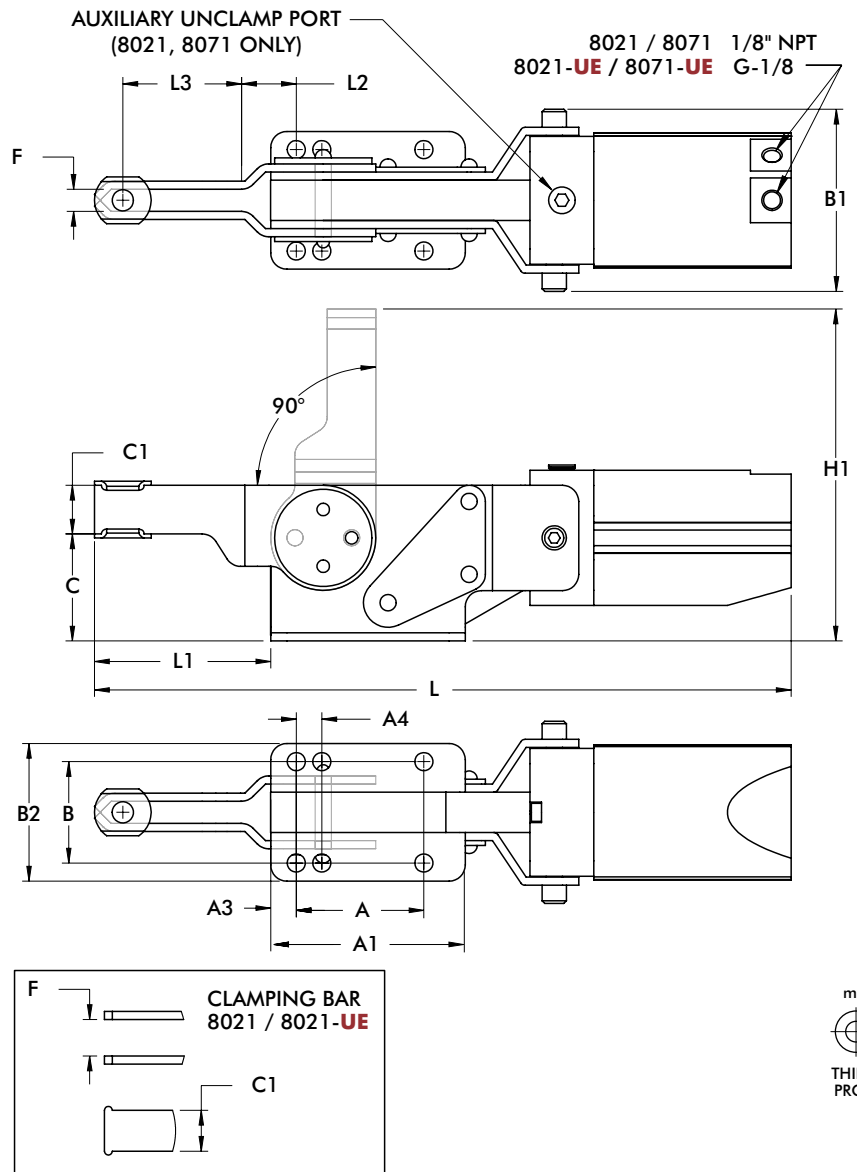

mm [INCH]  
THIRD ANGLE PROJECTION

Model	A	A1	A3	A4	B	B1	B2	C	C1	C2	ØD	F
8021	[0.79]	[1.97]	[0.47]	-	[1.50]	[2.26]	[1.88]	[1.56]	[0.63]	[0.13]	[0.21]	[0.56]
8021-UE	20	50	12	-	38,2	57,4	47,9	39,6	16	3,2	5,3	14,3
8071	[1.97]	[3.00]	[0.39]	[0.39]	[1.56]	[2.81]	[2.12]	[1.65]	[0.75]	[0.13]	[0.28]	[0.34]
8071-UE	50	76,2	10	10	39,7	71,4	53,9	41,9	19,1	3,2	7,1	8,7

Model	H	H1	L	L1	L2	L3	M
8021	[2.40]	[4.44]	[9.86]	[2.25]	[0.44]	[1.31]	1/4
8021-UE	60,9	112,8	250,4	57,2	11	33,2	M6
8071	[2.63]	[5.12]	[10.74]	[2.72]	[0.40]	[1.83]	5/16
8071-UE	66,9	130	272,9	69	10,1	46,5	M8

# 817, 827 SERIES

## Pneumatic Toggle Clamps | Product Overview

### Features:

- Dual mounting surfaces for maximum flexibility
- Sensor ready for round or T-slot style sensors
- Built-in flow restriction eliminates need for external flow controls

### Applications:

- Assembly
- Welding

### Also Available:

See page MC-ACC-1 for spindle accessories  
See page MC-PSC-38 for sensing options

817-U  
817-UE



817-S  
817-SE



827-U  
827-UE



827-S  
827-SE



## Technical Information | Holding Capacities

Model	Maximum Holding Capacity		Max. Exerting Force @ 5bar [72PSI]		Weight	Bore Size	Air Consumption† dm³ [ft³]	Port Size	Accessories (Supplied)		
	Inner	Outer	Inner	Outer					Spindle Accessory	Flanged Washers	Bolt Retainer
817-U	[375 lbf] 1670 N		[369 lbf] 1648 N					1/8NPT	--	507107	--
817-UE		[200 lbf] 890 N		[225 lbf] 1005 N	1,05kg [2.31lb]	[1.26] 32	[0.015] 0,42	G-1/8	225208-M		
817-S	[450 lbf] 2000 N		[360 lbf] 1608 N					1/8 NPT	--	--	207107
817-SE								G-1/8			
827-U	[600 lbf] 2670 N	[390 lbf] 1735 N		[309 lbf] 1383 N				1/8 NPT	--	235106	--
827-UE			[491 lbf] 2200 N		2,14kg [4.71lb]	[1.57] 40	[0.029] 0,83	G-1/8	240208-M		
827-S	[700 lbf] 3110 N	[330 lbf] 1470 N		[281 lbf] 1257 N				1/8 NPT	--	--	210114
827-SE								G-1/8			

†Per double stroke at 5bar [72PSI]

**Max Cylinder Pressure:** 10bar [145psig]\*

**Max Operating Temp:** -10°C to 90°C [-14°F to 194°F]

**Replacement Seal Kit:** 817: 802450-32-1-00  
827: 810450-40-1-00

**Replacement Clamp Assembly:** 817-U-LC, 817-S-LC, 827-U-LC, 827-S-LC

**Replacement Cylinder Assembly:** 817: 807CYL, 827: 810CYL

\*In no case should the inlet pressure be high enough to create an exerting force that exceeds the clamp's holding capacity. See Technical Appendix Section for details.

### Sensor Accessories

	Item Number
Round Reed Switch with Quick Disconnect	810169
T-slot Reed Switch with Quick Disconnect	8EA-109-1
Quick Disconnect 2M Extension Cable	CABL-010
Quick Disconnect 5M Extension Cable	CABL-013

See Pneumatic Accessories section for more options

# 817, 827 SERIES

Pneumatic Toggle Clamps | Dimensions | -U/-UE/-S/-SE

817-U  
817-UE



817-U / 817-S / 827-U / 827-S 1/8" NPT  
817-UE / 817-SE / 827-UE / 827-SE G-1/8

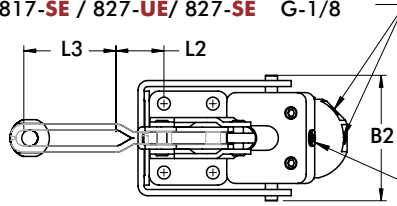

AUXILIARY UNCLAMP PORT  
(817-U, 817-S, 827-U, 827-S ONLY)

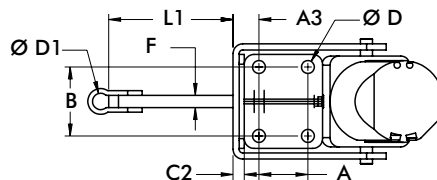
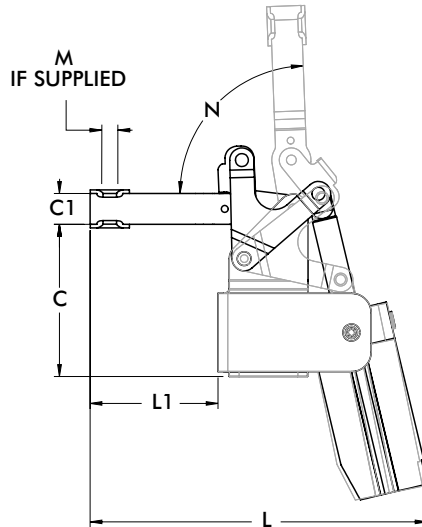
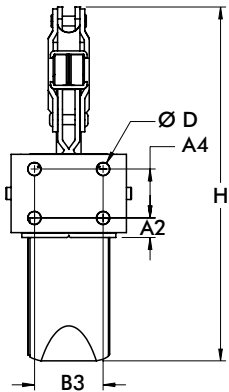

mm [INCH]  
THIRD ANGLE  
PROJECTION

### Mounting Options:

Use two bolts in the "side" mounting holes, to secure mounting bracket, when "top" mounting.

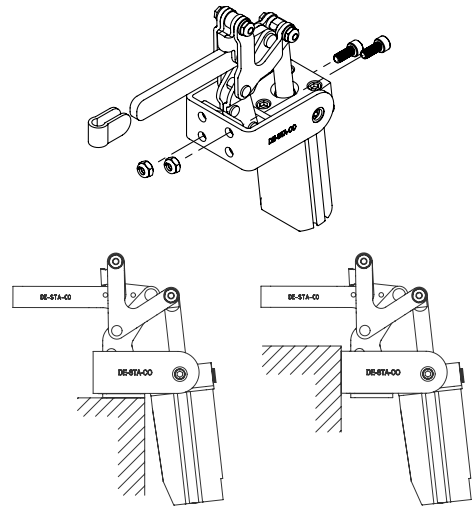

Top Mounting

Side Mounting

Model	A	A2	A3	A4	B	B2	B3	C	C1	C2	C3	C4
817-U												
817-UE	[0.63]	[0.44]	[0.60]	[0.63]	[1.00]	[2.44]	[1.00]	[2.69]	[0.63]	[0.12]	[1.25]	[1.31]
817-S	16	11,2	15,1	16	25,4	62	25,4	68,3	16	3,1	31,8	33,3
817-SE												
827-U								[3.89]	[0.79]			[1.76]
827-UE	[1.25]	[0.51]	[0.66]	[1.25]	[1.75]	[3.08]	[1.75]	98,8	20	[0.12]	[2.00]	44,8
827-S	31,8	12,8	16,8	31,8	44,45	78,3	44,45	[3.91]	[0.75]	3,1	50,8	[1.78]
827-SE								99,2	19,1			45,3

Model	ØD	ØD1	F	H	L	L1	L2	L3	M	N
817-U					[6.24]	[2.37]	[0.19]	[1.90]		
817-UE	[0.27]	-	-	[7.51]	158,6	60,3	4,8	48,4	5/16 M8	95°
817-S	6,7	[0.34]	[0.25]	190,7	[6.97]	[3.04]	-	-		
817-SE		8,7	6,4		175,5	77,2				
827-U					[8.61]	[3.27]	[1.23]	[2.35]		
827-UE	[0.33]	-	-	[9.04]	218,7	83,1	31,2	59,7	3/8 M10	88°
827-S	8,4	[0.42]	[0.31]	229,7	[8.49]	[3.18]	-	-		
827-SE		10,7	7,9		215,6	80,7				

# 868 SERIES

## Pneumatic Toggle Clamps | Product Overview

### Features:

- Hardened pins and bushing at all pivot points for long lifecycle
- Large, solid clamping arm is easily modified to suit application requirements
- Sensor ready for round or T-slot style sensors

### Applications:

- Assembly
- Welding

### Also Available:

See page MC-PSC-38 for sensing options

868  
868-E



## Technical Information | Holding Capacities

Model	Maximum Holding Capacity		Max. Exerting Force @ 5bar [72PSI]		Weight	Bore Size	Air Consumption† dm <sup>3</sup> [ft <sup>3</sup> ]	Port Size
	Inner	Outer	Inner	Outer				
868	[4000 lbf] 17800 N	[2400 lbf] 10675 N	[1704 lbf] 7637 N	[800 lbf] 3585 N	[17.0lb] 7,71kg	[2.48] 63	[0.109] 3,08	1/4 NPT
868-E								G-1/4

†Per double stroke at 5bar [72PSI]

**Max Cylinder Pressure:** 10bar [145psig]\*

**Max Operating Temp:** -10°C to 90°C [-14°F to 194°F]

**Replacement Seal Kit:** 850450-63-1-00

**Replacement Clamp Assembly:** 868-LC

**Replacement Cylinder Assembly:** 868CYL

\*In no case should the inlet pressure be high enough to create an exerting force that exceeds the clamp's holding capacity. See Technical Appendix Section for details.

### Sensor Accessories

	Item Number
Round Reed Switch with Quick Disconnect	810169
T-slot Reed Switch with Quick Disconnect	8EA-109-1
Quick Disconnect 2M Extension Cable	CABL-010
Quick Disconnect 5M Extension Cable	CABL-013

See Pneumatic Accessories section for more options



# 868 SERIES

## Pneumatic Toggle Clamps | Dimensions

868  
868-E

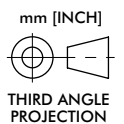
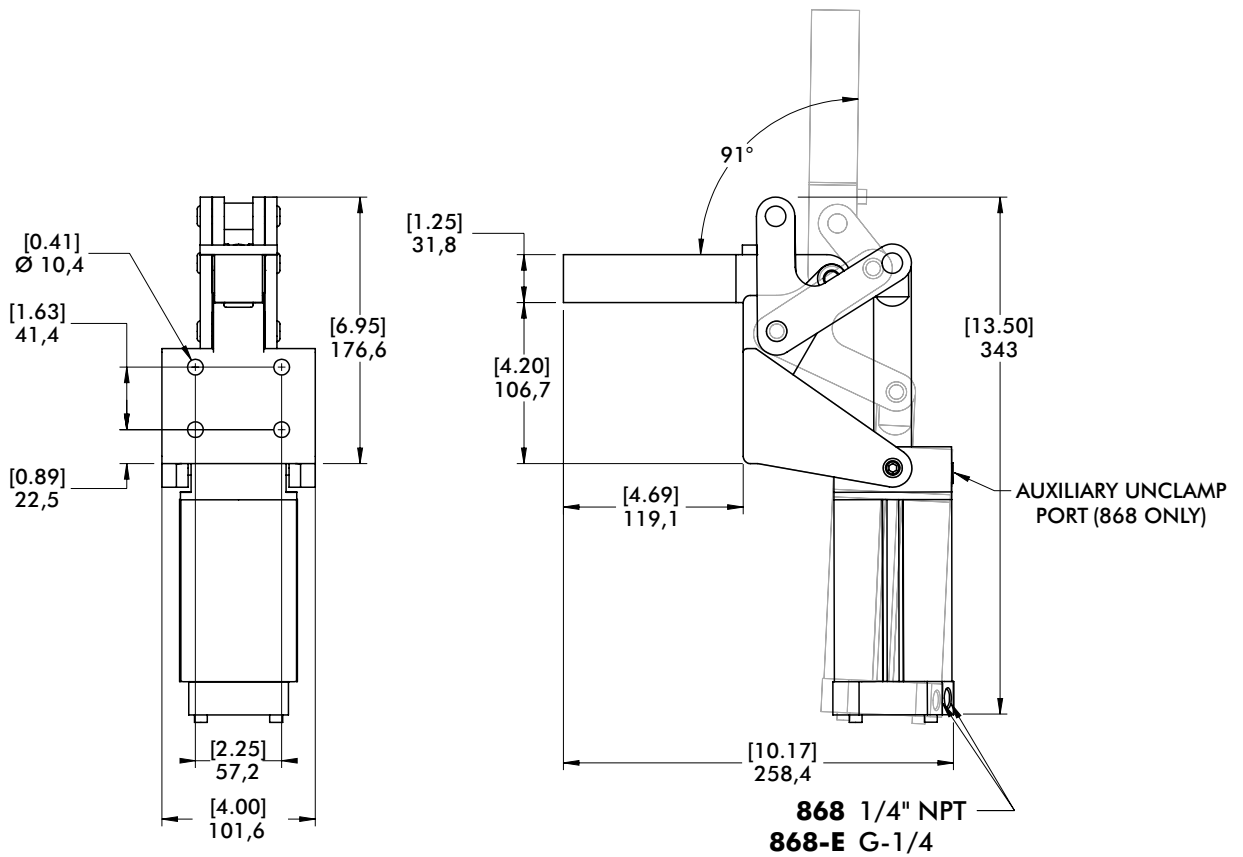
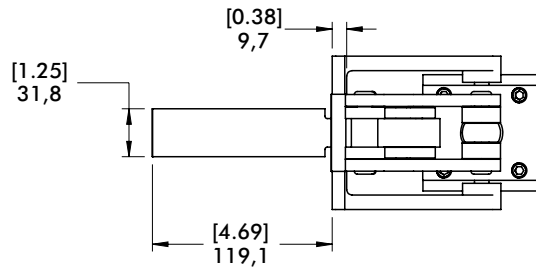

# 803 SERIES

## Pneumatic Toggle Clamps | Product Overview

### Features:

- Pneumatic version of Model 603 manual straight line action clamp
- Sensor ready for round or T-slot style sensors

### Applications:

- Assembly
- Welding

### Also Available:

See page MC-ACC-1 for spindle accessories

See page MC-PSC-38 for sensing options

High temperature version available  
Upon Request, add **-HT** to model number. Example: 803-U-**HT**

803  
803-ME



## Technical Information | Holding Capacities | Dimensions

Model	Maximum Holding Capacity	Maximum Exerting Force @ 5bar [72PSI]	Plunger Travel	Plunger Thread	Weight	Bore Size	Air Consumption† dm³ [ft³]	Port Size
803	[600 lbf] 2670 N	[675 lbf] 3015 N	[0.75] 19,1	5/16-18	[1.86lb] 0,84kg	[1.26] 32	[0.015] 0,42	1/8 NPT
803-ME				M8				G-1/8

†Per double stroke at 5bar [72PSI]

**Max Cylinder Pressure:** 10bar [145psig]

**Max Operating Temp:** -10°C to 90°C [-14°F to 194°F]

**Replacement Seal Kit:** 802450-32-1-00

**Replacement Clamp Assembly:** 803-LC, 803-M-LC

**Replacement Cylinder Assembly:** 807CYL

\*In no case should the inlet pressure be high enough to create an exerting force that exceeds the clamp's holding capacity.

See Technical Appendix Section for details.

### Sensor Accessories

Round Reed Switch with Qk Disconnect

T-slot Reed Switch with Qk Disconnect

Quick Disconnect 2M Extension Cable

Quick Disconnect 5M Extension Cable

See Pneumatic Accessories section for more options

### Item Number

810169

8EA-109-1

CABL-010

CABL-013

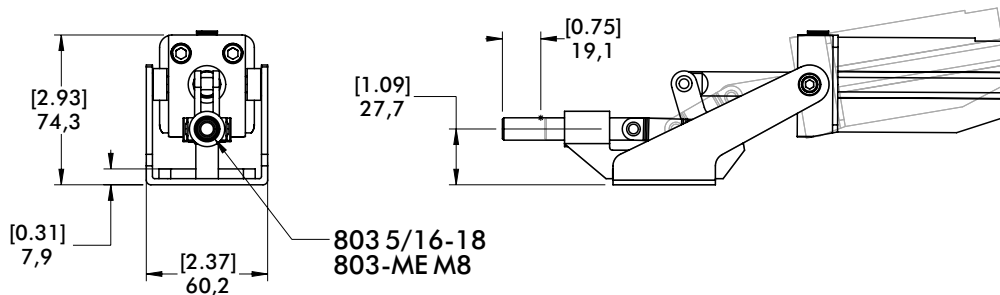
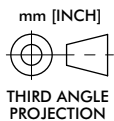
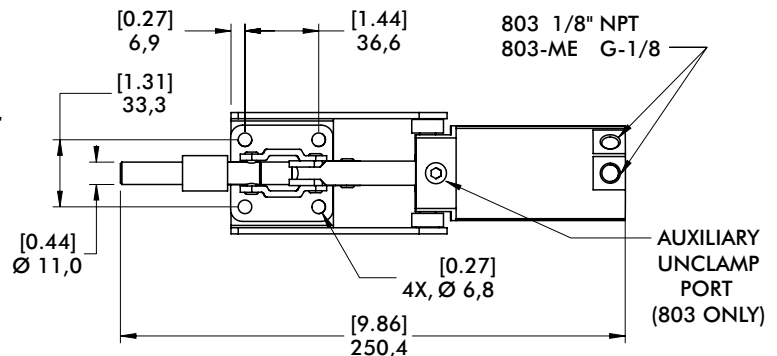

# 8031 SERIES

## Pneumatic Toggle Clamps | Product Overview

### Features:

- Fully enclosed straight line action clamp for the dirtiest environments
- Compact design with high holding capacity
- Sensor ready for round style sensors

### Applications:

- Assembly
- Welding

### Also Available:

See page MC-ACC-1 for spindle accessories  
See page MC-PSC-38 for sensing options

8031 ⓘ



## Technical Information | Holding Capacities | Dimensions

Model	Maximum Holding Capacity	Maximum Exerting Force @ 5bar [72PSI]	Plunger Travel	Plunger Thread	Weight	Bore Size	Air Consumption† dm³ [ft³]	Port Size
8031 ⓘ	[2000 lbf] 8900 N	[731 lbf] 3285 N	[0.75] 19,1	M8	[1.17lb] 2,58kg	[1.26] 32	[0.006] 0,18	1/8 NPT

**Max Cylinder Pressure:** 10bar [145psig]\*

**Max Operating Temp:** -10°C to 90°C [-14°F to 194°F]

\*In no case should the inlet pressure be high enough to create an exerting force that exceeds the clamp's holding capacity. See Technical Appendix Section for details.

### Sensor Accessories

	Item Number
Round Reed Switch with Quick Disconnect	810169
Quick Disconnect 2M Extension Cable	CABL-010
Quick Disconnect 5M Extension Cable	CABL-013

See Pneumatic Accessories section for more options

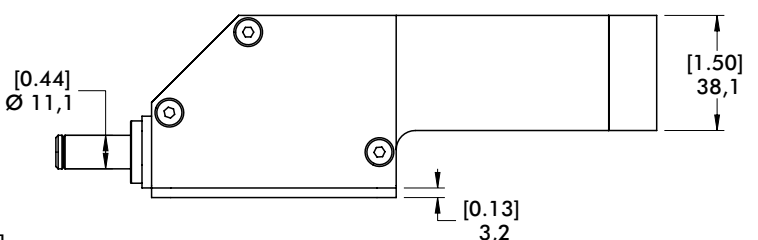
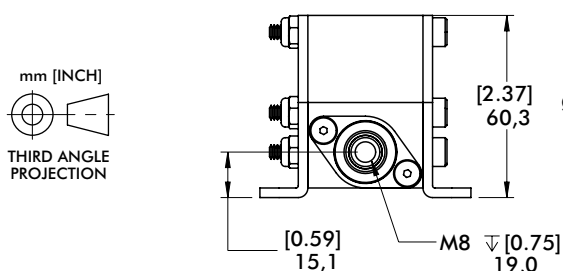
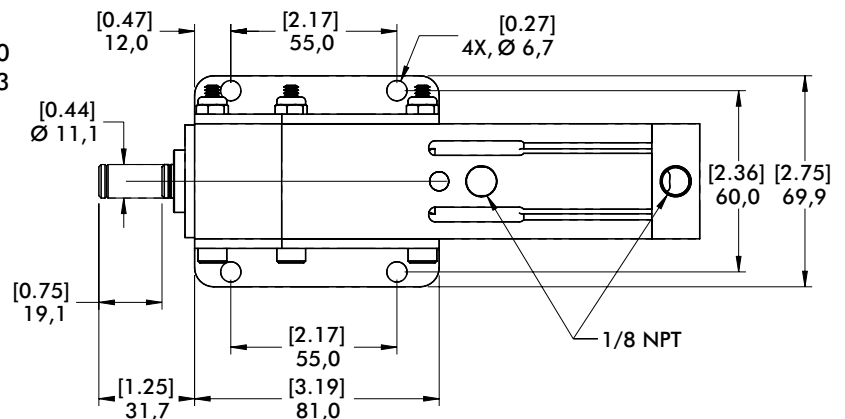

# 830 SERIES

## Pneumatic Toggle Clamps | Product Overview

### Features:

- Pneumatic version of Model 630 manual straight line action clamp
- Sensor ready for round or T-slot style sensors
- Built-in flow restriction eliminates need for external flow controls

### Applications:

- Assembly
- Welding

### Also Available:

See page MC-ACC-1 for spindle accessories  
See page MC-PSC-38 for sensing options

830  
830-ME



## Technical Information | Holding Capacities | Dimensions

Model	Maximum Holding Capacity	Maximum Exerting Force @ 5bar [72PSI]	Plunger Travel	Plunger Thread	Weight	Bore Size	Air Consumption† dm <sup>3</sup> [ft <sup>3</sup> ]	Port Size
830	[2500 lbf] 11100 N	[800 lbf] 3582 N	[0.75] 19,1	3/8-16	2,79kg [6.14lb]	[1.57] 40	[0.029] 0,83	1/8 NPT
830-ME				M10				G-1/8

†Per double stroke at 5bar [72PSI]

**Max Cylinder Pressure:** 10bar [145psig]  
**Max Operating Temp:** -10°C to 90°C [-14°F to 194°F]  
**Replacement Seal Kit:** 810450-40-1-00  
**Replacement Clamp Assembly:** 830-LC, 830-M-LC  
**Replacement Cylinder Assembly:** 810CYL

\*In no case should the inlet pressure be high enough to create an exerting force that exceeds the clamp's holding capacity. See Technical Appendix Section for details.

### Sensor Accessories

Round Reed Switch with Quick Disconnect  
T-slot Reed Switch with Quick Disconnect  
Quick Disconnect 2M Extension Cable  
Quick Disconnect 5M Extension Cable

### Item Number

810169  
8EA-109-1  
CABL-010  
CABL-013

See Pneumatic Accessories section for more options

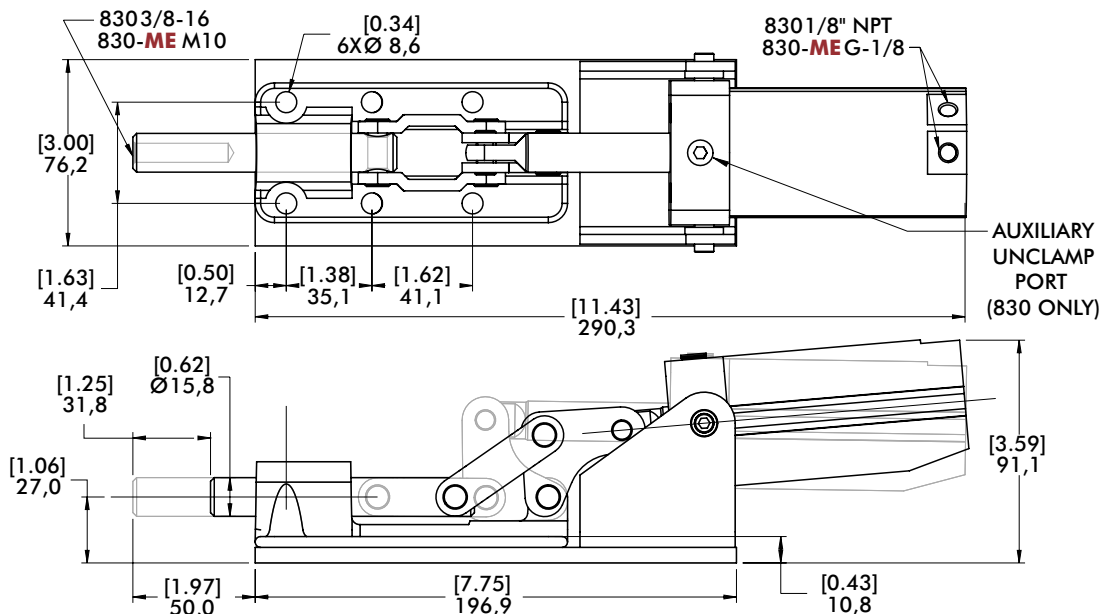

### Features:

- Pneumatic version of Model 650 manual straight line action clamp
- Sensor ready for round or T-slot style sensors
- Built-in flow restriction eliminates need for external flow controls

### Applications:

- Assembly
- Welding
- Light press operations

### Also Available:

See page MC-ACC-1 for spindle accessories  
See page MC-PSC-38 for sensing options

850 ⓘ  
850-ME ⓘ



## Technical Information | Holding Capacities | Dimensions

Model	Maximum Holding Capacity	Maximum Exerting Force @ 5bar [72PSI]	Plunger Travel	Plunger Thread	Weight	Bore Size	Air Consumption† dm³ [ft³]	Port Size
850 ⓘ	[16,000 lbf] 71200 N	[1232 lbf] 5522 N	[2.00] 50,8	5/8-11	[16.66lb] 7,56kg	[2.48] 63	[0.109] 3,08	1/4 NPT
850-ME ⓘ				M16				G-1/4

ⓘ This item is available upon request. †Per double stroke at 5bar [72PSI]

**Max Cylinder Pressure:** 10bar [145psig]  
**Max Operating Temp:** -10°C to 90°C [-14°F to 194°F]  
**Replacement Seal Kit:** 850450-63-1-00  
**Replacement Clamp Assembly:** 850-LC, 850-M-LC  
**Replacement Cylinder Assembly:** 868CYL

\*In no case should the inlet pressure be high enough to create an exerting force that exceeds the clamp's holding capacity. See Technical Appendix Section for details.

### Sensor Accessories

Round Reed Switch with Quick Disconnect  
T-slot Reed Switch with Quick Disconnect  
Quick Disconnect 2M Extension Cable  
Quick Disconnect 5M Extension Cable

### Item Number

810169  
8EA-109-1  
CABL-010  
CABL-013

See Pneumatic Accessories section for more options

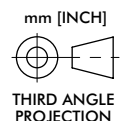
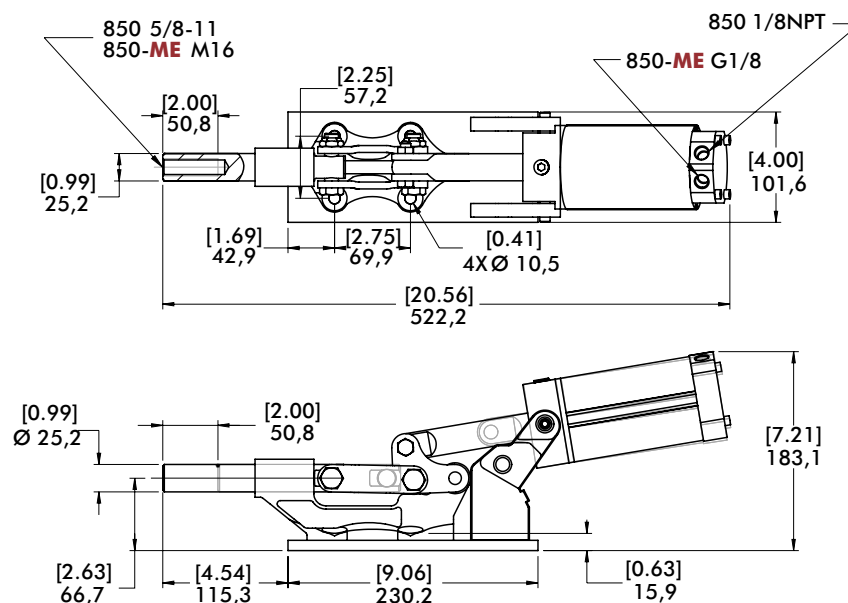

# 800, 1200 SERIES

## Pneumatic Toggle Clamps | Product Overview

### Features:

- Low profile and compact for mounting in tight spaces
- Uniform clamping force throughout full stroke
- Accommodates variable workpiece thickness
- Single acting - air advance, spring return

### Applications:

- Assembly
- Welding
- Light machining

### How it Works:

1. Clamp arm retracts fully for loading and unloading.
2. Clamp arm moves straight forward.
3. Clamp arm pivots down to hold workpiece.

800

800-E

1200 ⓘ

1200-E ⓘ



## Technical Information | Holding Capacities | Dimensions

Model	Inlet Pressure bar [PSI]	Exerting Force	Max. Pressure at Max. Mechanical Advantage† bar [PSI]	Clamping Range	Weight	Port Size
800	[70~150] 4,8~10,3	[850~1500 lbf] 3780~6670N	4,8 [70]	[0.09] 2,3	[2.50lb] 1,13kg	1/4 NPT
800-E		[650~1200 lbf] 2890~5340N		[0.16] 4,0		
1200 ⓘ		[750~1600 lbf] 3340~7120N		[0.25] 6,4	[4.00lb] 1,81kg	
1200-E ⓘ		[550~1200 lbf] 2450~5340N		[0.38] 9,6		

ⓘ This item is available upon request

**Note:** For use with pneumatic power only. This is a single acting device (air clamp, spring return), a 3-way air valve required for control.

**Repair Kits:** 800-00,  
1200-00

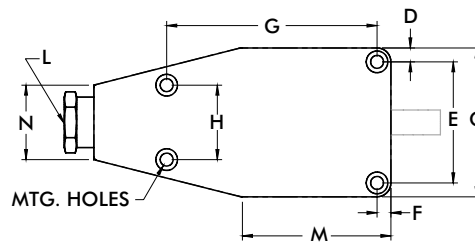

**Note:**  
K (Forward Stroke)  
R (Downward Stroke)

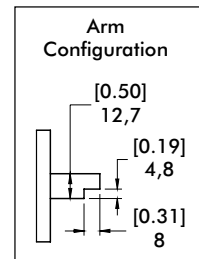
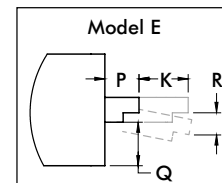

Model	A	B	C	D	E	F	G	H	K	L	M	N	P	Q	R	MNTG HOLES	
800	[1.63] 41,4	[4.81] 122,8	[2.72] 69,1	[0.25] 6,4	[2.21] 56,1	[0.25] 6,4	[3.13] 79,5	[1.19] 30,2	[0.50] 12,7	1/4 NPT	[2.31] 58,37	[1.50] 38,1	-	[0.59] 15,0	[0.09] 2,3	[0.26] 6,6	
800-E													[0.50] 12,7		[0.16] 4,1		
1200	[2.25] 57,2	[6.00] 152,4	[3.00] 76,2	[0.28] 7,1	[2.44] 62	[0.28] 7,1	[4.25] 108	[1.50] 38,1	[1.00] 25,4			[3.00] 76,2	[1.38] 35,1	-	[0.63] 16		[0.25] 6,4
1200-E														[0.69] 17,5			[0.38] 9,7



# 9500 SERIES

## Pneumatic Swing Clamps | Product Overview

### Features:

- Ideal for tight spaces with an arm motion that rotates at the top of the stroke
- Includes a rod weld cover to protect the rod throughout the entire stroke
- Can be mounted on any face with optional side flange mounting kit
- Switch ready for Ø4mm or 6.5mm x 5mm sensors

### Applications:

- Assembly
- Welding
- Light machining

### Also Available:

- See page MC-PSC-6 for mounting options
- See page MC-PSC-7 for clamping arms
- See page MC-PSC-40 for sensing options

Covered under one or more U.S./International Patents

9522-2



9530-2



9540-2



9550-2



Shown with optional clamping arm.

## Technical Information

Model	Swing Direction	Total Stroke [in.]mm	Stroke During Rotation [in.]mm	Vertical Clamping Stroke [in.]mm	Clamping Force @ [lbf.]N†	Bore Size [in.]mm	Air Consumption‡ dm³[in³]	Weight [lb.].kg	Replacement Seal Kit		
9522-2L	LH	[0.50]		[0.50]	[34]	[0.86]	[0.004]	[0.68]	952292		
9522-2R	RH	13		13	150	22	0,10	0,31			
9530-2L	LH	[0.79]	--	[0.79]	[76]	[1.26]	[0.010]	[1.25]	953092 954092		
9530-2GL	RH				340	32	0,29	0,57			
9530-2R											
9530-2GR											
9540-2L	LH				20	20	[123]	[1.57]		[0.016]	[1.98]
9540-2GL	RH						550	40		0,46	0,90
9540-2R											
9540-2GR											
9550-2L	LH	[0.79]	--	[0.79]	[196]	[1.97]	[0.026]	[3.33]	955092		
9550-2GL	RH				870	50	0,74	1,51			
9550-2R											
9550-2GR											

† with standard clamping arm at 5bar [72psi]. ‡ Per double stroke at 5bar [72psi]

**Operating Pressure Range:** 3bar [45psig] to 8bar [120psig]

**Maximum Operating Temperature:** 60°C [140°F]



# 9500 SERIES

## Pneumatic Swing Clamps | Dimensions

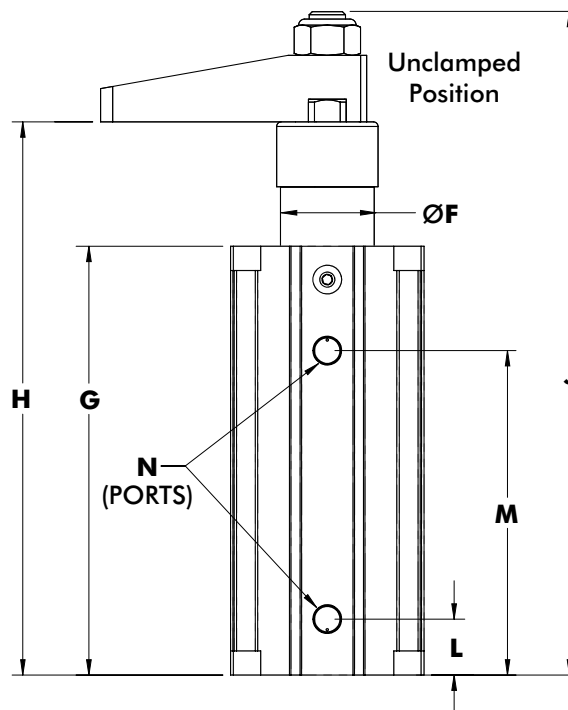
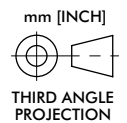
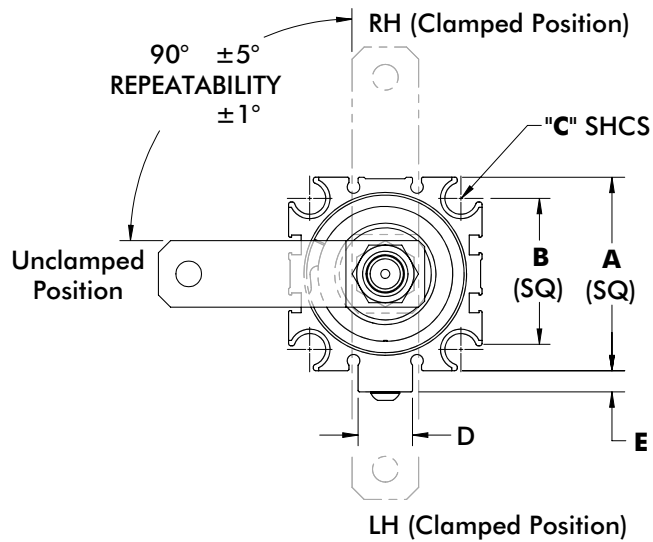
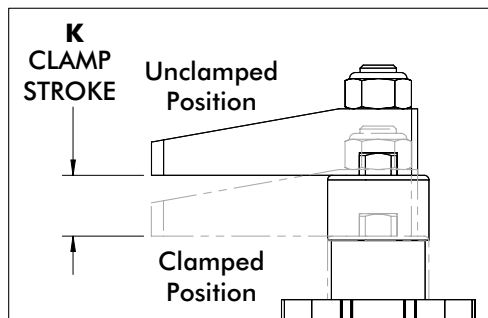
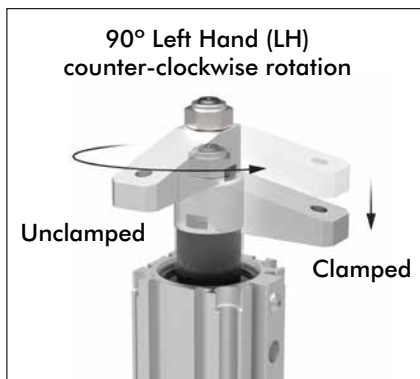
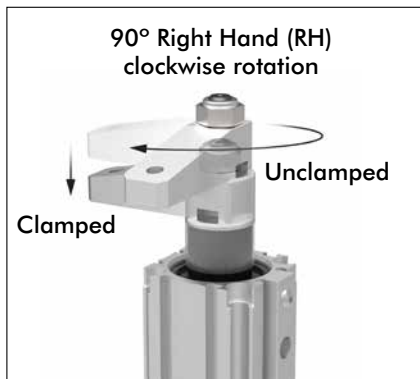

Shown with optional clamping arm.

Model	A	B	C	D	E	F	G	H	J	K	L	M	N
9522-2	[1.42] 36	[1.00] 25,4	M5 (#10)	--	--	[0.82] 21	[3.77] 95,8	[4.79] 121,8	[5.72] 145,7	[0.50] 13	[0.43] 11	[2.90] 73,8	M5
9530-2	[1.81] 46	[1.34] 34	M6 (1/4")	[0.55] 14	[0.16] 4	[0.96] 24,4	[4.48] 113,7	[6.09] 154,8	[7.33] 186	[0.79] 20	[0.61] 15,5	[3.39] 86,2	1/8NPT
9530-2G													
9540-2	[2.05] 52	[1.57] 40			[0.20] 5	[1.13] 28,7	[4.63] 117,6	[6.29] 159,7	[7.52] 190,9		[0.65] 16,5	[3.43] 87,1	1/8NPT
9540-2G													G-1/8
9550-2	[2.52] 64	[1.97] 50	M8 (5/16")	[0.71] 18	[0.28] 7	[1.32] 33,5	[5.58] 141,8	[7.20] 182,9	[8.64] 219,3		[0.73] 18,5	[4.22] 107,3	1/8NPT
9550-2G													G-1/8

# 9500 SERIES

## Pneumatic Swing Clamps | Clamping Forces

Series 9522-2 Clamping Force

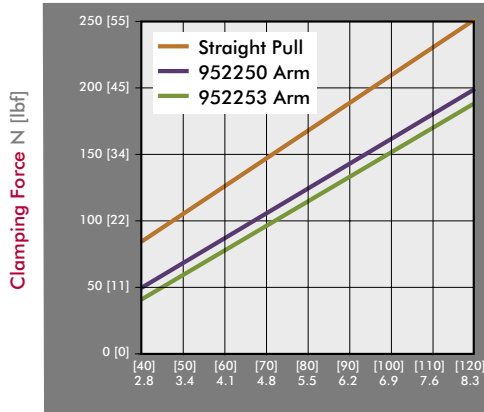

Inlet Pressure bar [PSI]

Series 9530-2 Clamping Force

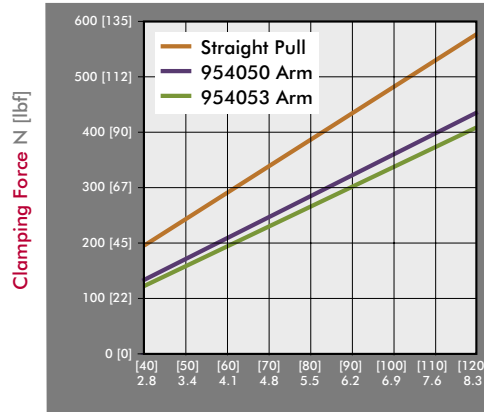

Inlet Pressure bar [PSI]

Series 9540-2 Clamping Force

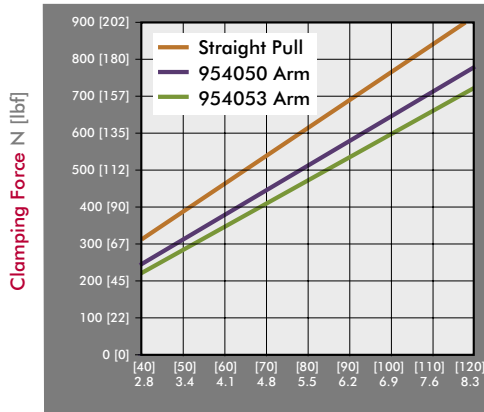

Inlet Pressure bar [PSI]

Series 9550-2 Clamping Force

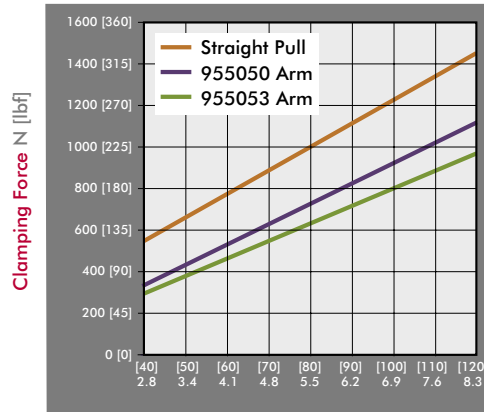

Inlet Pressure bar [PSI]

## Guidelines

DESTACO Pneumatic Swing Clamps are designed for long life when using standard clamping arms and spindles. In the event that a longer arm or additional weight is needed, please consult these charts for the allowable weight and length.

### Example: 9522-2

At a weight of 80 gr, the maximum length of the arm is approximately 120mm.

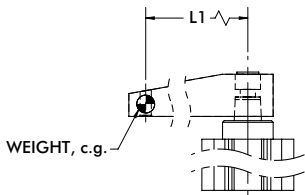

All data refers to an operating pressure of 5 bar [72psi] and an opening and closing time of 1 second.

9522-2 Clamp Arm Weight

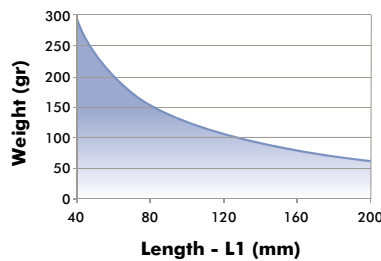

9530-2 Clamp Arm Weight

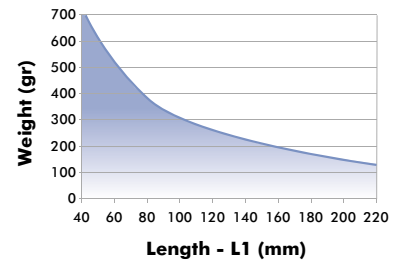

9540-2 Clamp Arm Weight

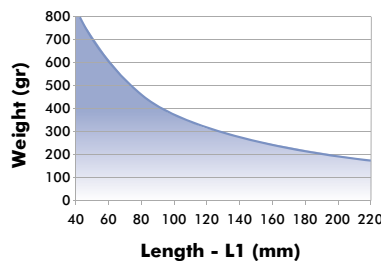

9550-2 Clamp Arm Weight

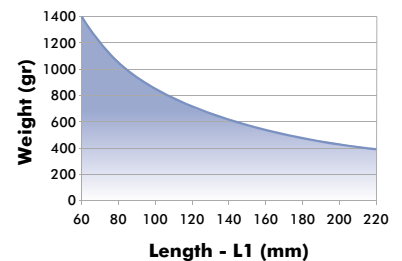

# 9500 SERIES

## Pneumatic Swing Clamps | Mounting Accessories

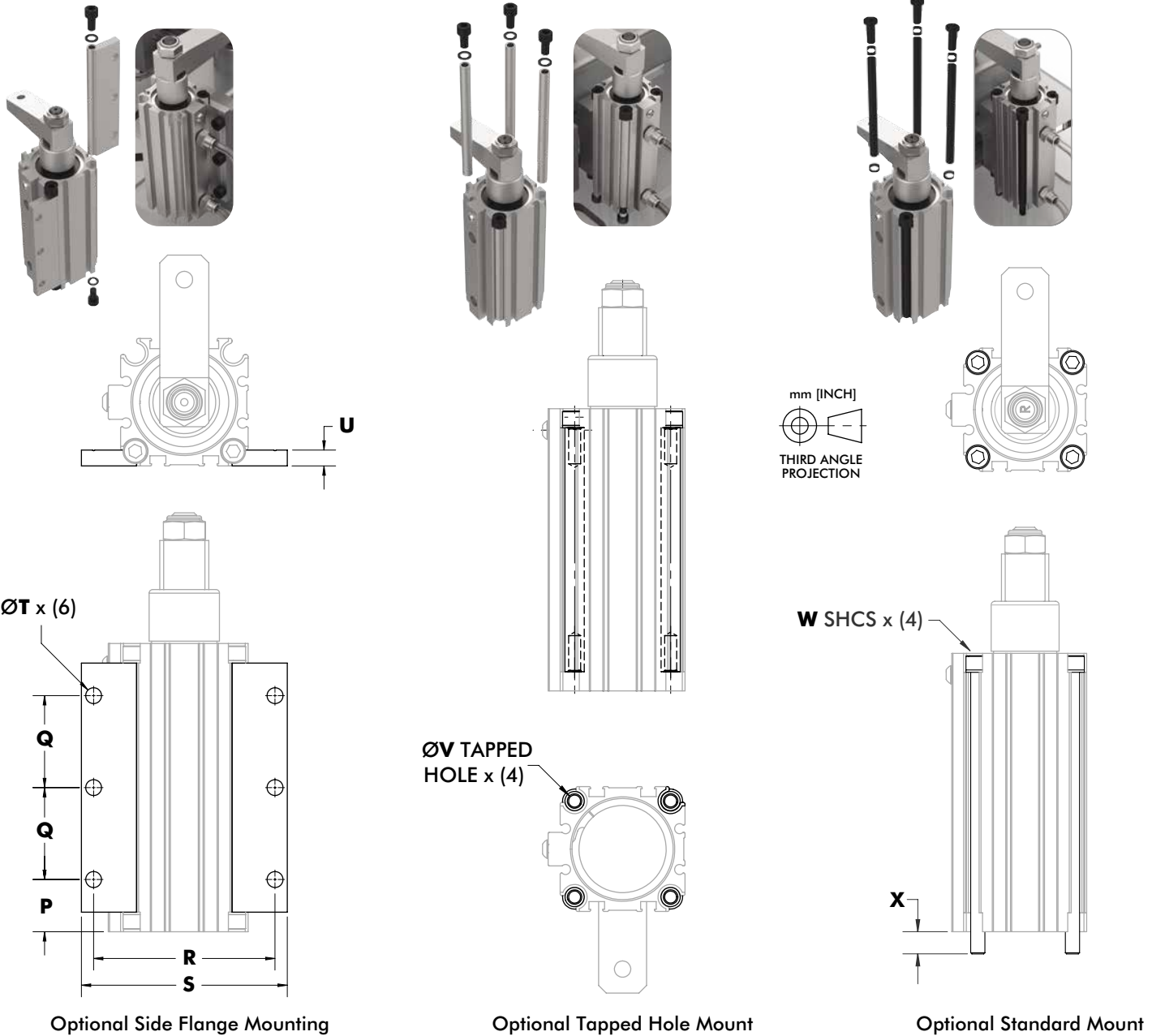

Model	P	Q	R	S	T	U	V	W	X	Side Flange Kit	Tapped Hole Kit	Standard Mount Kit
9522-2	[0.41] 10,4		[1.91] 48,5	[2.26] 57,5	[0.22] 5,5	[0.22] 5,5	M5	M5x100	[0.36] 9,2	952260	952261	952262
9530-2	[0.76] 19,4	[1.48] 37,5	[2.68] 68	[3.07] 78					[0.52] 13,3	953060	953061	
9530-2G					[0.26] 6,5	[0.26] 6,5	M6	M6x120				953062
9540-2	[0.84] 21,3		[2.91] 74	[3.31] 84					[0.37] 9,4	954060	954061	
9540-2G												
9550-2	[0.82] 20,9	[1.97] 50	[3.66] 93	[4.17] 106	[0.33] 8,5	[0.31] 8	M8	M8x150	[0.59] 15	955060	955061	955062
9550-2G												

Refer to NPN-9500-2 for mounting instructions

# 9500 SERIES

## Pneumatic Swing Clamps | Clamping Arms

### Features:

- Lightweight aluminum construction
- Designed for use with 9500-2 series clamps

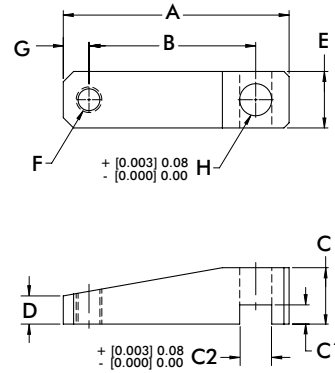
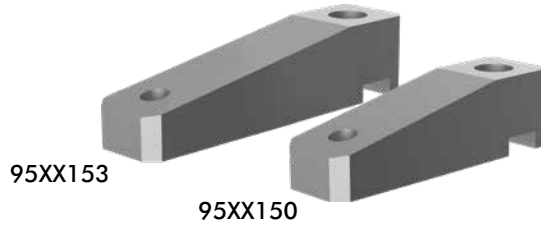

Part Number	Used with Model	A	B	C	C1	C2	D	E	F	G	H	Weight [lbs] kg
9522150	9522-2	[2.28] 58	[1.77] 45	[0.59]	[0.16]	[0.315]	[0.30]	[0.59]	M6	[0.20] 5	[0.315] 8,00	[0.06] 0,025
9522153		[3.07] 78	[2.56] 65	15	4	8,01	7.50	15				[0.08] 0,034
9540150	9530-2, 9540-2	[2.76] 70	[1.97] 50	[0.79]	[0.18]	[0.394]	[0.39]	[0.79]	M8	[0.39] 10	[0.394] 10,00	[0.12] 0,054
9540153		[3.94] 100	[3.15] 80	20	4,6	10,01	10	20				[0.17] 0,079
9550150	9550-2	[3.46] 88	[2.56] 65	[0.87]	[0.30]	[0.493]	[0.43]	[0.87]	M10	[0.39] 10	[0.492] 12,50	[0.18] 0,081
9550153		[4.45] 113	[3.54] 90	22	7,5	12,51	11	22				[0.23] 0,11

### Features:

- Swing direction is field adjustable between left, right, or straight. (20mm not linear adjustable)
- Switch ready for Ø4mm or 6.5mm x 5mm sensors
- Lightweight and robust, designed for several million cycles
- Clamp arm sold separately

### Applications:

- Assembly
- Welding
- Light machining

### Also Available:

See page MC-PSC-11 thru 13 for clamping arms and mounting accessories

See page MC-PSC-40 for sensing options

89R



## Technical Information

Model	Swing Direction*	Total Stroke [in]mm	Stroke During Rotation [in]mm	Vertical Clamp Stroke [in]mm	Clamping Force† [lbf]N	Bore Size [in]mm	Air Consumption‡ [ft³]dm³	Weight [lb.]kg	Replacement Seal Kit
89R20-010-2	LH, RH	[0.83] 21	[0.43] 11		[18] 80	[0.79] 20	[0.002] 0,07	[0.66] 0,3	89R20-00
89R32-010-2	LH, RH, STRT	[1.10] 28	[0.61] 18	[0.39] 10	[55] 245	[1.26] 32	[0.009] 0,25	[1.32] 0,6	89R32-00
89R40-010-2		[1.24] 31,5	[0.85] 21,5		[85] 380	[1.57] 40	[0.015] 0,43	[2.09] 0,95	89R40-00
89R40-025-2		[1.83] 46,5					[0.022] 0,63	[2.43] 1,1	
89R50-025-2		[2.05] 52	[1.06] 27	[0.98] 25	[138] 614	[1.97] 50	[0.040] 1,13	[3.97] 1,8	89R50-00
89R63-025-2		[2.30] 58,5	[1.32] 33,5		[218] 970	[2.48] 63	[0.072] 2,04	[6.17] 2,8	89R63-00

\*Swing direction is field adjustable. †with standard clamping arm 5bar [72psi]. ‡per double stroke at 5bar [72psi]

**Operating Pressure Range:** 3bar [45psig] to 8bar [120psig]

**Maximum Operating Temperature:** 60°C [140°F]

### Note:

Switches are optional. To order with (2) 8EA-109-1 switches, add **A** to the end of the model. Ex. 89R32-010-2**A**

# 89R SERIES

## Pneumatic Swing Clamps | Dimensions

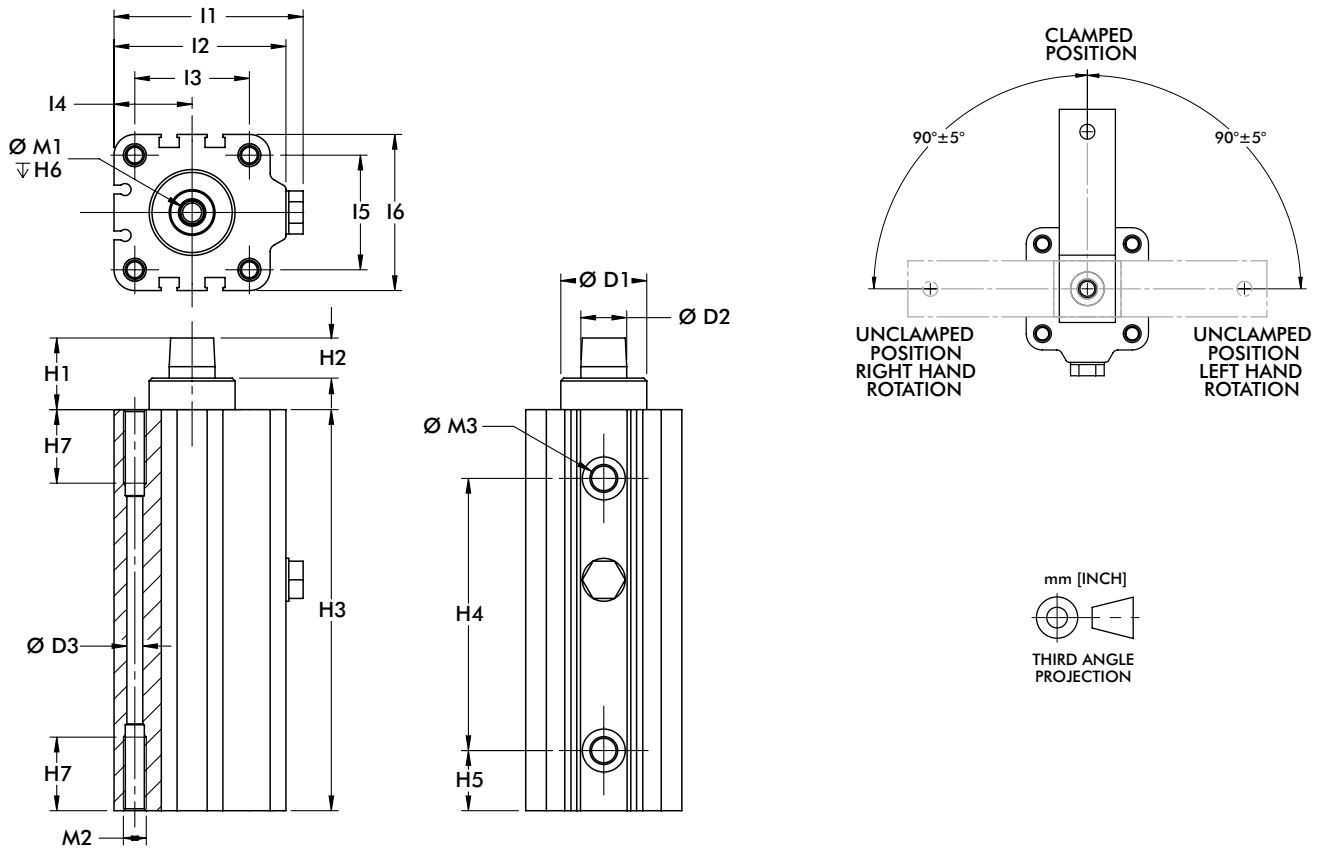

Model	ØD1 H9	ØD2 F7	ØD3	H1	H2	H3	H4	H5	H6	H7	L1	L2
89R20-010-2	[0.71] 18	[0.39] 10	[0.18] 4,6	[0.78] 19,8	[0.47] 11,9	[4.15] 105,5	[2.60] 66	[0.52] 13,2	[0.59] 15	[0.55] 14	[1.56] 39,5	[1.38] 35
89R32-010-2	[0.87] 22	[0.47] 12		[0.93] 23,7		[4.92] 125	[3.27] 83	[0.69] 17,5		[0.63] 16	[2.36] 60	[2.13] 54
89R40-010-2	[1.18] 30	[0.63] 16	[0.22] 5,5	[0.98] 25	[0.43] 11	[5.51] 140	[3.74] 95	[0.83] 21	[0.67] 17		[2.60] 66	[2.36] 60
89R40-025-2						[6.69] 170	[4.92] 125			[0.98] 25		
89R50-025-2	[1.57] 40	[0.71] 18	[0.29] 7,4	[1.24] 31,4		[7.70] 195,5	[5.39] 137	[1.05] 26,7	[0.98] 25		[3.09] 78,5	[2.85] 72,5
89R63-025-2	[1.77] 45	[0.78] 20	[0.37] 9,3	[1.30] 33	[0.59] 15	[8.33] 211,5	[6.08] 154,5	[1.04] 26,5			[3.74] 95	[3.46] 88

Model	L3	L4	L5	L6	M1	M2	M3
89R20-010-2	[0.87] 22	[0.63] 16	[0.87] 22	[1.26] 32	M5	M6	M5
89R32-010-2	[1.42] 36	[0.94] 24	[1.26] 32	[1.77] 45	M6		
89R40-010-2	[1.57] 40	[1.07] 27,3	[1.57] 40	[2.15] 54,5	M8	M8	G-1/8
89R40-025-2							
89R50-025-2	[1.97] 50	[1.28] 32,5	[1.97] 50	[2.56] 65	M10	M10	
89R63-025-2	[2.44] 62	[1.57] 40	[2.44] 62	[3.15] 80	M10	M12	G-1/4

Series 89R Clamping Force  
(w/ standard clamping arm)

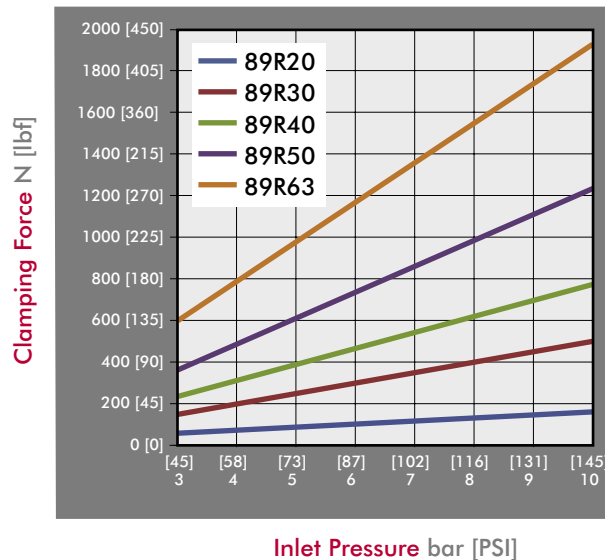

### Guidelines

DESTACO Pneumatic Swing Clamps are designed for long life when using standard clamping arms and spindles. In the event that a longer arm or additional weight is needed, please consult these charts for the allowable weight and length.

**Example: 89R32**

At a weight of 80 gr, the maximum length of the arm is approximately 90mm.

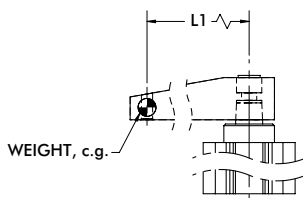

All data refers to an operating pressure of 5 bar [72psi] and an opening and closing time of 1 second.

89R20 & 89R32 Clamp Arm Weight

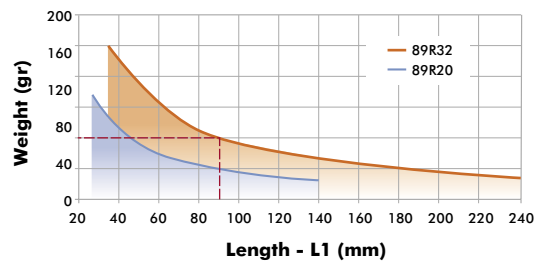

89R40 & 89R50 Clamp Arm Weight

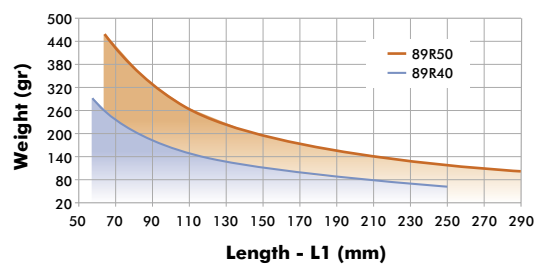

89R63 Clamp Arm Weight

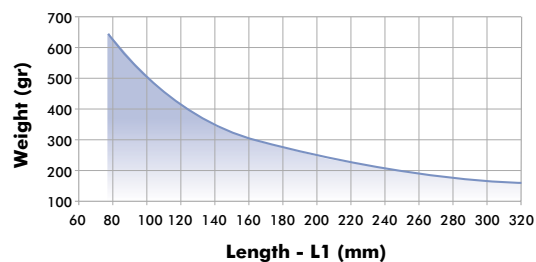

# 89R SERIES

## Pneumatic Swing Clamps | Clamping Arms

### Features:

- Lightweight aluminum construction
- Locking tapered connection for 360 deg. arm positioning

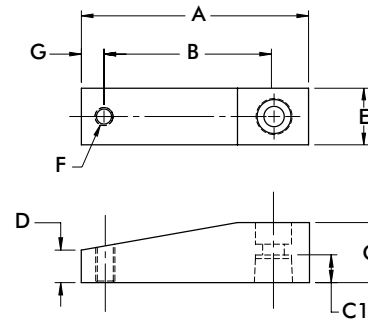

Part Number	Used with Model	A	B	C	C1	D	E	F	G	Weight [lbs] kg
8JG-215-1	89R20-010-2	[2.64] 67	[2.05] 52	[0.59] 15	[0.33] 8,5	[0.33] 8,5	[0.59] 15	M6	[0.28] 7	[0.08] 0,04
8JG-217-1	89R32-010-2	[3.15] 80	[2.36] 60	[0.79] 20	[0.37] 9,5		[0.79] 20	M8	[0.39] 10	[0.14] 0,06
8JG-218-1	89R40-010-2, 89R40-025-2	[3.74] 95	[2.76] 70	[0.98] 25	[0.45] 11,5	[0.55] 14	[0.98] 25			[0.28] 0,13
8JG-219-1	89R50-025-2	[4.17] 106	[3.15] 80	[1.18] 30	[0.59] 15	[0.57] 14,5	[1.18] 30	M10	[0.47] 12	[0.42] 0,19
8JG-220-1	89R63-025-2	[4.72] 120	[3.54] 90	[1.38] 35	[0.67] 17	[0.67] 17	[1.38] 35			[0.66] 0,30

## Clamping Arm Adapters

### Features:

- For attaching custom made clamp arms
- 360° rotatable arm
- Aluminum construction

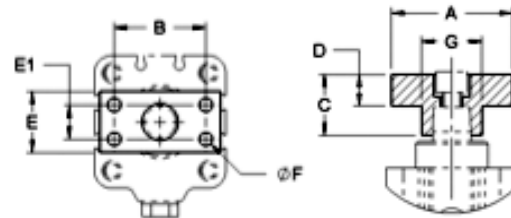
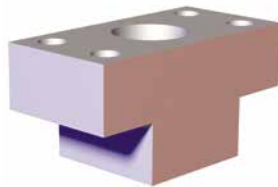

Part Number	Used with Model	A	B	C	D	E	E1	F	Weight [lbs] kg
8MA-084-1	89R20-010-2	[1.57] 40	[1.10] 28	[0.59] 15	[0.32] 8	[0.59] 15	--	[0.22] 5,5 (2x)	[0.03] 0,014
8MA-086-1	89R32-010-2	[1.97] 50	[1.38] 35	[0.79] 20	[0.43] 11	[0.79] 20			[0.08] 0,035
8MA-087-1	89R40-010-2, 89R40-025-2		[1.50] 38	[0.98] 25	[0.51] 13	[0.98] 25	[0.55] 14	[0.22] 5,5 (4x)	[0.11] 0,050
8MA-088-1	89R50-025-2	[2.36] 60	[1.77] 45	[1.18] 30	[0.59] 15	[1.18] 30	[0.59] 15	[0.28] 7 (4x)	[0.19] 0,085
8MA-089-1	89R63-025-2	[2.56] 65	[1.89] 48	[1.38] 35	[0.67] 17	[1.38] 35	[0.71] 18	[0.35] 9 (4x)	[0.28] 0,125



# 89R SERIES

## Pneumatic Swing Clamps | Body Mount Flanges

### Features:

- For recessed mounting
- Variable height adjustment
- Can be used with switches
- For use with the **89R** Series Pneumatic Swing Clamps

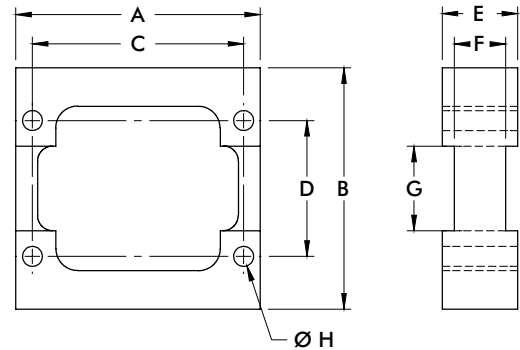

Part Number	Used with Model	A	B	C	D	E	F	G	H	Weight [lbs] kg
8MA-092-1	89R20-010-2	[2.24] 57	[2.17] 55	[1.85] 47	[0.94] 24	[0.59] 15	--	--	[0.28] 5,5	[0.22] 0,10
8MA-094-1	89R32-010-2		[2.95] 75		[1.57] 40	[0.79] 20	[0.47] 12	[0.98] 25		[0.44] 0,20
8MA-095-1	89R40-010-2	[3.19] 81	[3.15] 80	[2.55] 70	[1.77] 45	[0.98] 25	[0.67] 17	[1.10] 28	[0.26] 6,6	[0.55] 0,25
	89R40-025-2							[1.46] 37	[0.35] 9	[0.88] 0,40
8MA-096-1	89R50-025-2	[4.00] 101,5	[3.94] 100	[3.37] 85,5	[1.97] 50					

## Mounting Feet

### Features:

- Can be mounted on bottom side or front side
- Can be mounted on 4 sides of the cylinder
- For use with **89R** Series Pneumatic Swing Clamps

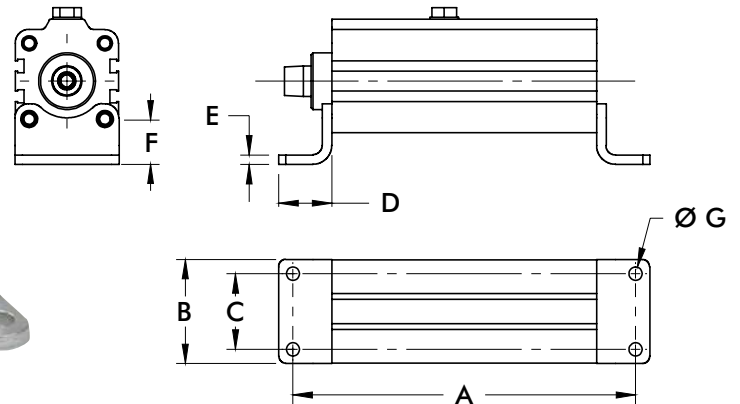

Part Number	Used with Model	A	B	C	D	E	F	G	Weight [lbs] kg
8MW-018-1	89R20-010-2	[5.41] 137,5	[1.38] 35	[0.87] 22	[0.87] 22	[0.16] 4	[0.63] 16		[0.08] 0,04
8MW-020-1	89R32-010-2	[6.54] 166	[1.97] 50	[1.38] 35			[0.71] 18	[0.28] 7	[0.15] 0,07
8MW-021-1	89R40-010-2	[7.13] 181	[2.17] 55	[1.57] 40	[1.10] 28	[0.20] 5	[0.94] 24		[0.22] 0,10
	89R40-025-2	[8.31] 211						[0.35] 9	[0.33] 0,15
8MW-022-1	89R50-025-2	[9.39] 238,5	[2.64] 67	[1.97] 50	[1.26] 32	[0.24] 6	[1.06] 27	[0.43] 11	[0.52] 0,24
8MW-023-1	89R63-025-2	[10.37] 263,5	[3.35] 85	[2.44] 62	[1.57] 40				

# 89R SERIES

## Pneumatic Swing Clamps | End Mount Flanges

### Features:

- Can be mounted on bottom side or top side
- For use with **89R** Pneumatic Swing Clamps

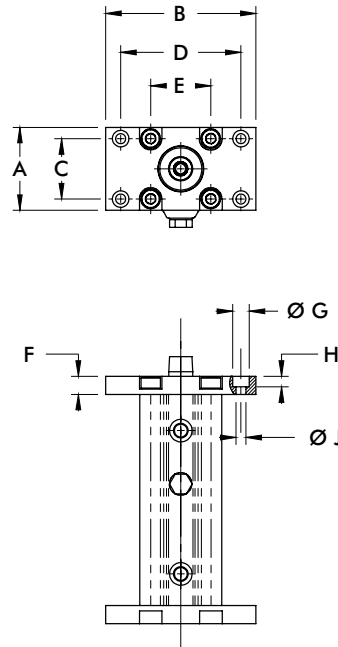

Part Number	Used with Model	A	B	C [±0.008] ±0,2	D [±0.008] ±0,2	E	F	G	H	J	Weight [lbs]kg
8MA-061-1	89R20-010-2	[1.26] 32	[2.56] 65	[0.71] 18	[1.97] 50	[0.87] 22	[0.39] 10				[0.07] 0,03
8MA-063-1	89R32-010-2	[1.97] 50	[3.15] 80	[1.26] 32	[2.52] 64	[1.26] 32	[0.47] 12	[0.43] 11	[0.28] 7	[0.26] 6,6	[0.20] 0,09
8MA-064-1	89R40-010-2, 89R40-025-2	[2.17] 55	[3.94] 100	[1.57] 40	[3.15] 80	[1.57] 40					[0.29] 0,13
8MA-065-1	89R50-025-2	[2.56] 65	[4.72] 120	[1.77] 45	[3.94] 100	[1.97] 50	[0.59] 15	[0.59] 15	[0.35] 9	[0.33] 8,5	[0.46] 0,21
8MA-066-1	89R63-025-2	[3.15] 80	[5.12] 130	[2.36] 60	[4.33] 110	[2.44] 62				[0.35] 8,8	[0.66] 0,30

### Features:

- Lightweight and robust, designed for several millions cycles
- Can be mounted from the side or the top
- Sensor ready for T-slot style sensors
- Metric design
- Clamp arm sold separately

### Applications:

- Assembly
- Welding
- Light machining

### Also Available:

See page MC-PSC-17 for clamping arms  
See page MC-PSC-40 for sensing options

### Series 89B



### Technical Information

Model	Swing Direction	Total Stroke [in]mm S	Stroke During Rotation [in]mm S1	Vertical Clamp Stroke [in]mm S2	Clamping Force [lbf.] N†	Bore Size mm[in]	Air Consumption‡ [ft³]dm³	Weight [lb.]kg	Replacement Seal Kit
89B20-010-2R	RH	[0.79]	[0.39]		[29]	[0.79]	[0.003]	[1.46]	89B/E20-2-00
89B20-010-2L	LH	20	10		130	20	0,08	0,66	
89B32-010-2R	RH	[0.83]	[0.43]	[0.39]	[79]	[1.25]	[0.008]	[2.25]	89B/E32-2-00
89B32-010-2L	LH	21	11	10	350	32	0,22	1,02	
89B40-010-2R	RH	[0.94]	[0.55]		[130]	[1.57]	[0.014]	[3.17]	89B/E40-2-00
89B40-010-2L	LH	24	14		580	40	0,39	1,44	
89B50-025-2R	RH	[1.57]	[0.59]	[0.98]	[225]	[1.97]	[0.036]	[5.95]	89B/E50-2-00
89B50-025-2L	LH	40	15	25	1000	50	1,03	2,70	
89B63-008-2R	RH	[1.02]	[0.71]	[0.32]	[321]	[2.48]	[0.038]	[6.39]	89B/E63-2-00
89B63-008-2L	LH	26	18	8	1430	63	1,08	2,90	

† with standard clamping arm at 6bar [87psi]. ‡ per double stroke at 6bar [87psi]

**Operating Pressure Range:** 3bar [45psig] to 6bar [87psig]

**Maximum Operating Temperature:** 80°C [176°F]

### Note:

Switches are optional. To order clamp with (2) 8EA-109-1 switches, add **A** to the end of the model. EX. 89B30-010-2**RA**. See page MC-PSC-40 for additional switch options.

# 89B SERIES

## Pneumatic Swing Clamps | Dimensions

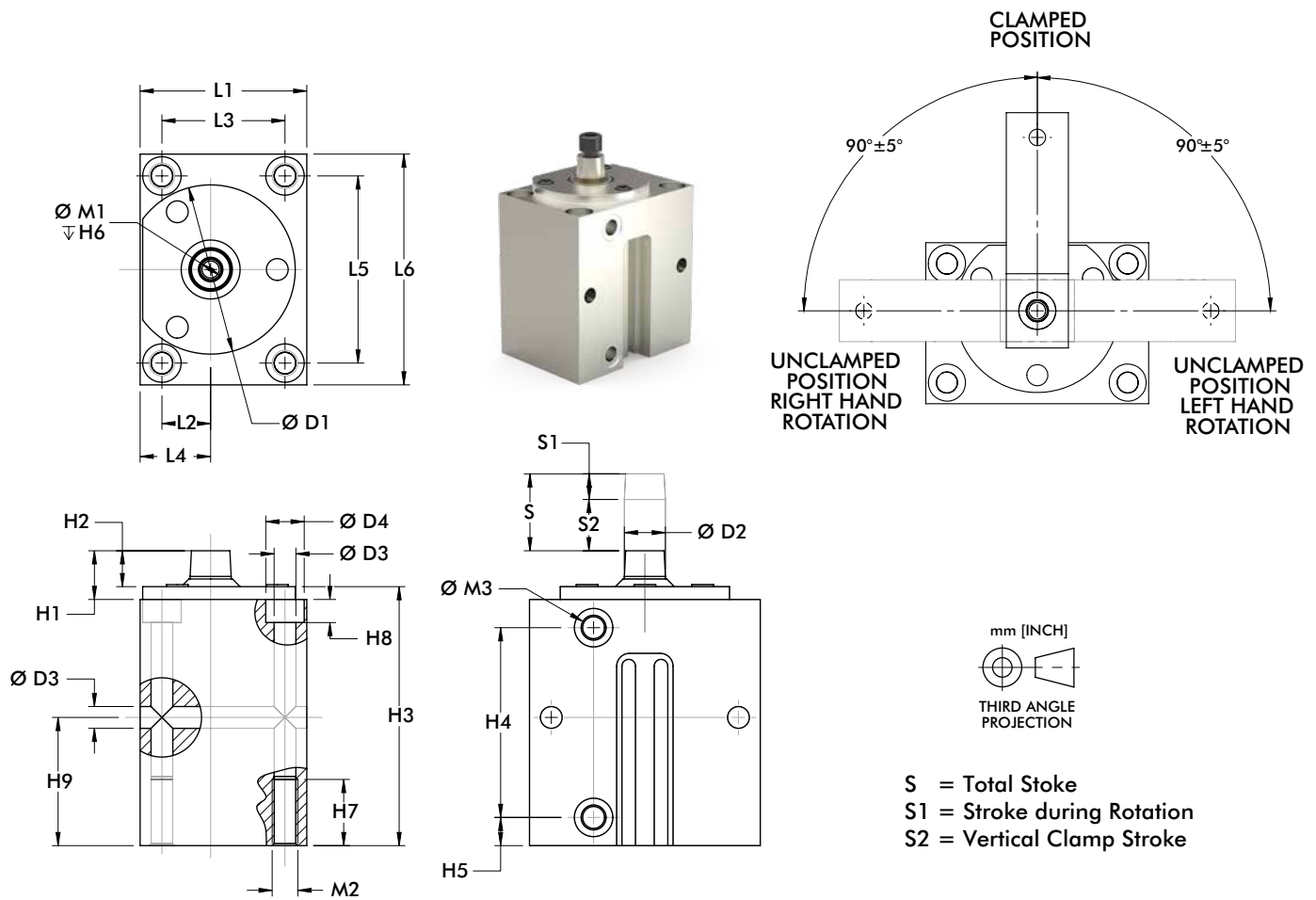

Model	ØD1	ØD2	ØD3	D4	H1	H2	H3	H4	H5	H6	H7	H8	H9	L1
89B20	[1.89] 48	[0.39] 10	[0.26] 6,6	[0.43] 11	[0.69] 17,5	[0.35] 9	[3.48] 88.5	[2.28] 58	[0.35] 9	[0.59] 15	[0.79] 20	[0.28] 7	[1.57] 40	[1.77] 45
89B32	[2.20] 56	[0.47] 12	[0.33]	[0.59]	[0.63] 16	[0.43] 11	[3.70] 94	[2.72] 69	[0.39] 10	[0.67] 17	[0.98] 25	[0.35] 9	[1.77] 45	[2.17] 55
89B40	[2.60] 66	[0.63] 16	8,5	15	[0.75] 19	[0.55] 14	[3.98] 101	[2.91] 74					[1.97] 50	[2.56] 65
89B50	[3.07] 78	[0.71] 18	[0.41]	[0.71]	[0.98] 25	[0.67] 17	[5.51] 140	[4.29] 109	[0.43] 11	[0.98] 25	[1.18] 30	[0.43] 11	[2.76] 70	[2.95] 75
89B63	[3.70] 94	[0.79] 20	10,5	18	[1.06] 27	[0.75] 19	[4.53] 115	[3.35] 85					[2.16] 55	[3.54] 90

Model	L2	L3	L4	L5	L6	M1	M2	M3
89B20	[0.45] 11,5	[1.18] 30	[0.75] 19	[2.36] 60	[2.95] 75	M5	M8	M5
89B32	[0.55] 14	[1.50] 38	[0.89] 22,5	[2.68] 68	[3.35] 85	M6	M10	
89B40	[0.75] 19	[1.89] 48	[1.08] 27,5	[2.87] 73	[3.54] 90	M8		G-1/8
89B50	[0.94] 24	[2.17] 55	[1.34] 34	[3.54] 90	[4.33] 110		M12	
89B63	[1.18] 30	[2.76] 70	[1.57] 40	[3.94] 100	[4.72] 120	M10		G-1/4

### Mounting Options

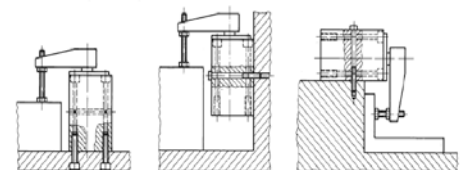

### Series 89B Clamping Force (w/ standard clamping arm)

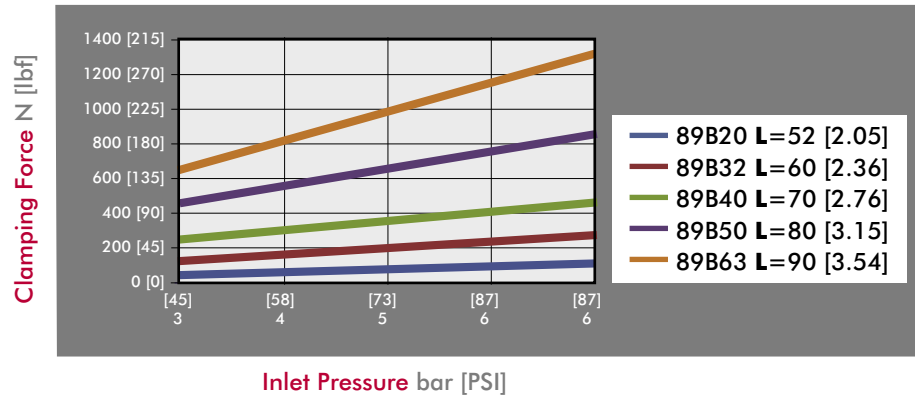

## Guidelines

DESTACO Pneumatic Swing Clamps are designed for long life when using standard clamping arms and spindles. In the event that a longer arm or additional weight is needed, please consult these charts for the allowable weight and length.

### Example: 89B32

At a weight of 80 gr, the maximum length of the arm is approximately 90mm.

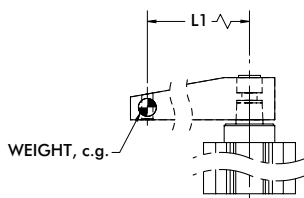

All data refers to an operating pressure of 5 bar [72psi] and an opening and closing time of 1 second.

### 89B20 & 89B32 Clamp Arm Weight

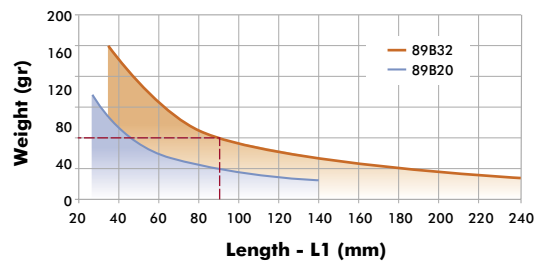

### 89B40 & 89B50 Clamp Arm Weight

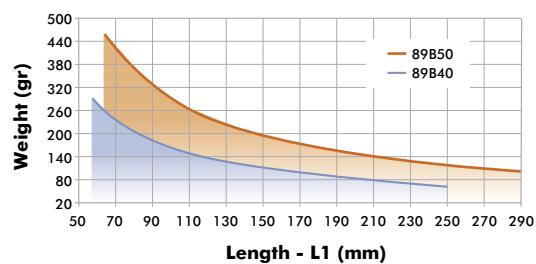

### 89B63 Clamp Arm Weight

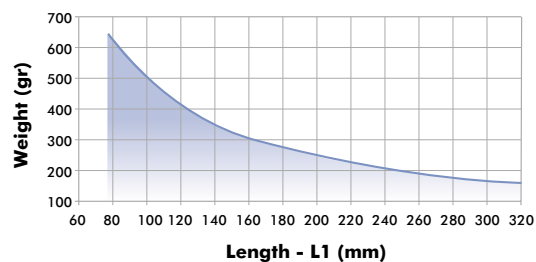

# 89B SERIES

## Pneumatic Swing Clamps | Clamping Arm

### Features:

- Lightweight aluminum construction
- Locking tapered connection for 360 deg. arm positioning

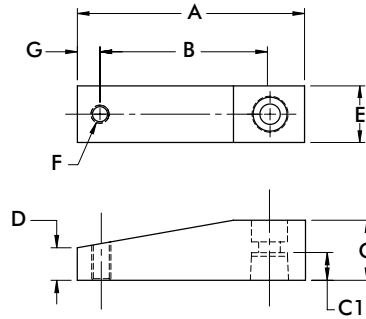

Part Number	Used with Model	A	B	C	C1	D	E	F	G	Weight [lbs] kg
8JG-215-1	89B20-010-2	[2.64] 67	[2.05] 52	[0.59] 15	[0.33] 8,5	[0.33] 8,5	[0.59] 15	M6	[0.28] 7	[0.08] 0,04
8JG-217-1	89B32-010-2	[3.15] 80	[2.36] 60	[0.79] 20	[0.37] 9,5		[0.79] 20	M8	[0.39] 10	[0.14] 0,06
8JG-218-1	89B40-010-2	[3.74] 95	[2.76] 70	[0.98] 25	[0.45] 11,5	[0.55] 14	[0.98] 25			[0.28] 0,13
8JG-219-1	89B50-025-2	[4.17] 106	[3.15] 80	[1.18] 30	[0.59] 15	[0.57] 14,5	[1.18] 30	M10	[0.47] 12	[0.42] 0,19
8JG-220-1	89B63-008-2	[4.72] 120	[3.54] 90	[1.38] 35	[0.67] 17	[0.67] 17	[1.38] 35			[0.66] 0,30

## Clamping Arm Adapters

### Features:

- For attaching custom made clamp arms
- 360° rotatable arm
- Aluminum construction

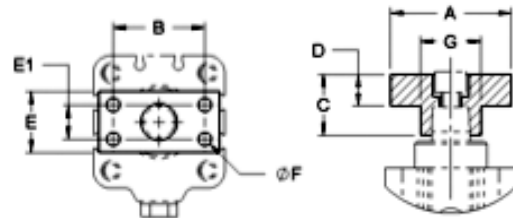
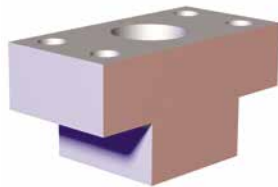

Part Number	Used with Model	A	B	C	D	E	E1	F	Weight [lbs] kg
8MA-084-1	89B20-010-2	[1.57] 40	[1.10] 28	[0.59] 15	[0.32] 8	[0.59] 15	--	[0.22] 5,5 (2x)	[0.03] 0,014
8MA-086-1	89B32-010-2	[1.97] 50	[1.38] 35	[0.79] 20	[0.43] 11	[0.79] 20			[0.08] 0,035
8MA-087-1	89B40-010-2		[1.50] 38	[0.98] 25	[0.51] 13	[0.98] 25	[0.55] 14	[0.22] 5,5 (4x)	[0.11] 0,050
8MA-088-1	89B50-025-2	[2.36] 60	[1.77] 45	[1.18] 30	[0.59] 15	[1.18] 30	[0.59] 15	[0.28] 7 (4x)	[0.19] 0,085
8MA-089-1	89B63-008-2	[2.56] 65	[1.89] 48	[1.38] 35	[0.67] 17	[1.38] 35	[0.71] 18	[0.35] 9 (4x)	[0.28] 0,125



# 8100, 8300 SERIES

## Pneumatic Swing Clamps | Product Overview

### Features:

- Lightweight and robust, designed for several millions cycles
- Block style body may be mounted from the side or the top.
- Sensor ready for use with round style sensors
- Clamp arm and spindle included

### Applications:

- Assembly
- Welding
- Light machining

### Also Available:

See page MC-PSC-22 for clamping arms  
See page MC-PSC-40 for sensing options

**8115**  
Right-hand  
Swing



**8116**  
Left-hand  
Swing



**8315**  
Right-hand  
Swing



**8316**  
Left-hand  
Swing



## Technical Information

Model	Swing Direction	Total Stroke [in]mm	Stroke During Rotation [in]mm	Vertical Clamp Stroke [in]mm	Clamping Force [lbf.] N†	Bore Size mm[in]	Air Consumption‡ [ft³]dm³	Weight [lb.]kg	Replacement Seal Kit
8115	RH	[0.85]	[0.47]	[0.38]	[25]	[18]	[0.002]	[0.68]	801560
8116	LH	21,5	11,8	9,7	110	80	0,06	0,31	
8315	RH	[1.25]	[0.75]	[0.50]	[89]	[67]	[0.014]	[2.00]	821560
8316	LH	31,8	19,1	12,7	400	298	0,40	0,91	

† with standard clamping arm at 5bar [72psi]. ‡ per double stroke at 5bar [72psi]

**Operating Pressure Range:** 3bar [45psig] to 9bar [130psig]

**Maximum Operating Temperature:** -18°C to 60°C [0°F to 140°F]

### Note:

To order without clamping arm add **-LA** to the end of the model. Ex. 8315-**LA**





# 8100, 8300 SERIES

## Pneumatic Swing Clamps | Dimensions



Unclamped



Clamped

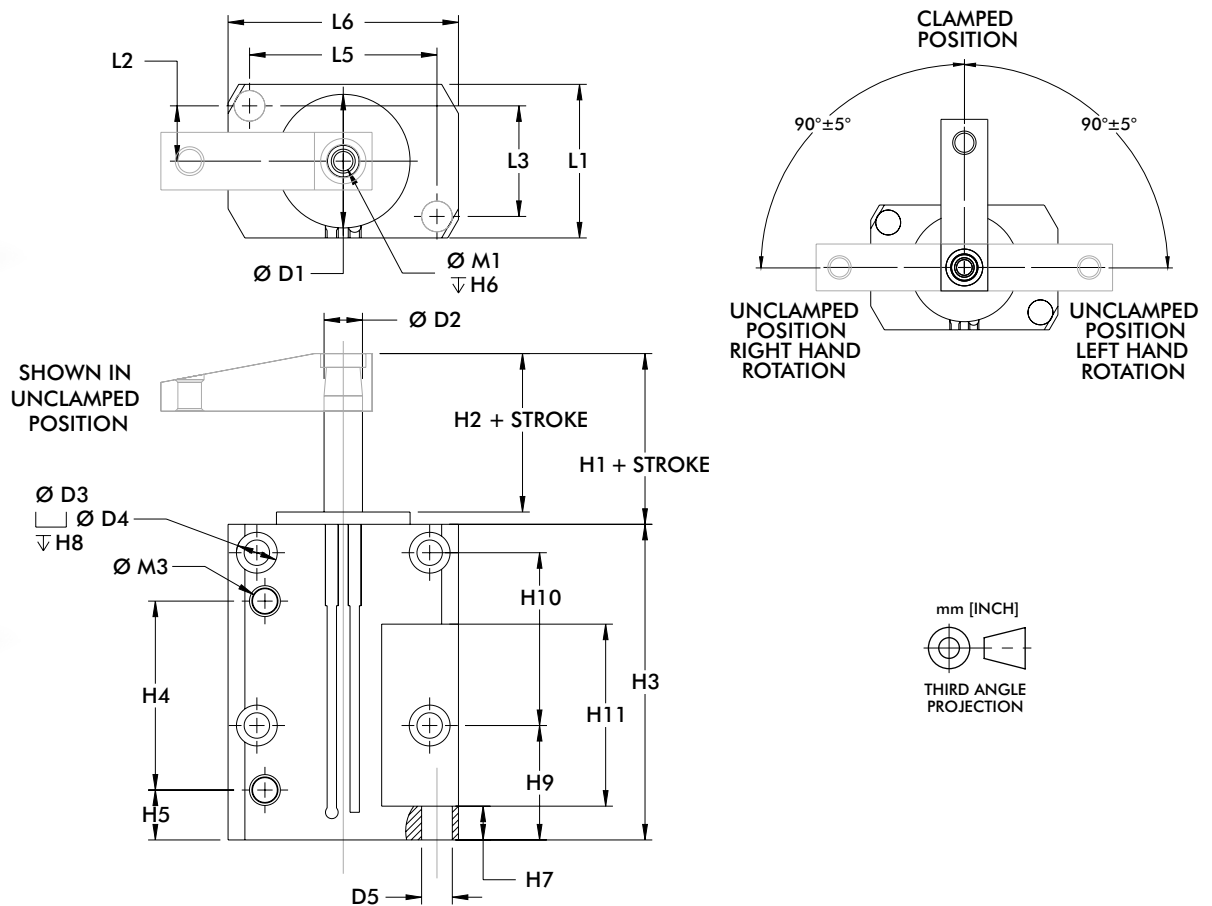

Model	ØD1	ØD2	ØD3	ØD4	ØD5	Stroke	H1	H2	H3	H4	H5	H6
8115	[1.23]	[0.44]	[0.20]	--	--	[0.85]	[0.53]	[0.41]	[3.37]	[1.45]	[0.35]	[0.75]
8116	31,2	11,2	5,1	--	--	21,5	13,5	10,4	85,6	36,8	8,9	19,1
8315	[1.74]	[0.50]	[0.33]	[0.53]	[0.40]	[1.25]	[0.97]	[0.81]	[4.11]	[2.46]	[0.65]	[0.67]
8316	44,2	12,7	8,4	13,5	10,2	31,8	24,6	20,6	104,4	62,5	16,5	17

Model	H7	H8	H9	H10	H11	L1	L2	L3	L5	L6	M1	M3
8115	[0.25]	--	[1.37]	[1.00]	[1.00]	[1.25]	[0.47]	[0.94]	[0.94]	[1.25]	¼-20	#10-32
8116	6,4	--	34,8	25,4	25,4	31,8	11,9	23,9	23,9	31,8	¼-20	#10-32
8315	[0.44]	[1.00]	[1.49]	[2.25]	[2.37]	[2.00]	[0.72]	[1.44]	[2.44]	[3.00]	5/16/18	1/8 NPT
8316	11,2	25,4	37,9	57,2	60,2	50,8	18,3	36,6	62	76,2	5/16/18	1/8 NPT

### Mounting Options

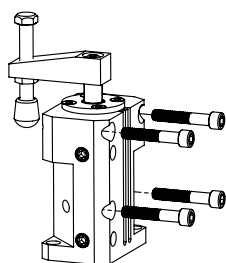

Can be mounted to the side or front of the fixture, or mounted back to back for multiple clamping operations.

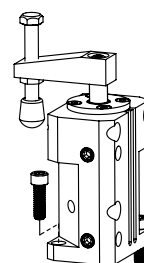

Mounted to the top of the work surface through the two mounting holes in the bottom of unit.

# 8100, 8300 SERIES

## Pneumatic Swing Clamps | Clamping Forces

Series 8100, 8300 Clamping Force  
(w/ standard clamping arm)

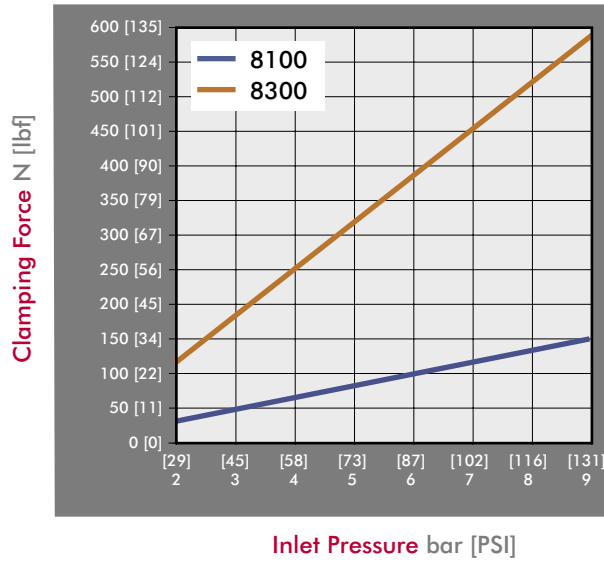

### Guidelines

DESTACO Pneumatic Swing Clamps are designed for long life when using standard clamping arms and spindles. In the event that a longer arm or additional weight is needed, please consult these charts for the allowable weight and length.

#### Example: 8315

At a weight of 80 gr, the maximum length of the arm is approximately 90mm.

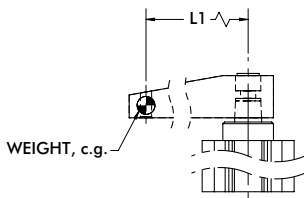

All data refers to an operating pressure of 5 bar [72psi] and an opening and closing time of 1 second.

8115/8116 Clamp Arm Weight

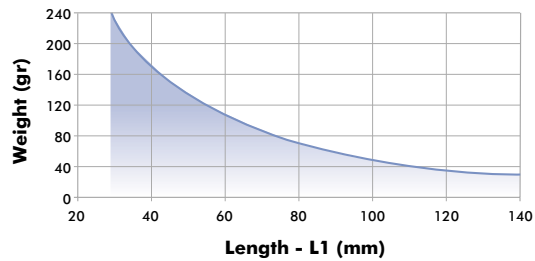

8315/8316 Clamp Arm Weight

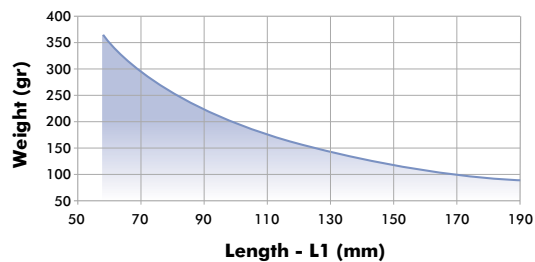

# 8100, 8300 SERIES

## Pneumatic Swing Clamps | Clamping Arms

### Features:

- Lightweight aluminum construction
- Locking tapered connection for 360 deg. arm positioning

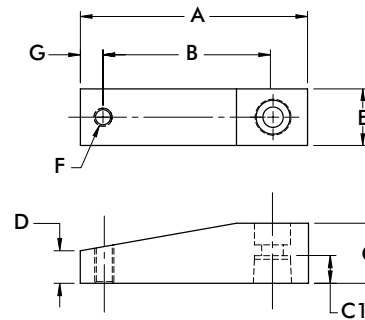

Part Number	Used with Model	A	B	C	C1	D	E	F	G	Weight [lbs] kg
801528	8115, 8116	[1.74] 44,2	[1.11] 28,2	[0.37] 9,4	[0.33] 8,3	[0.25] 6,4	[0.62] 15,7	#10-32	[0.32] 8,1	[0.03] 0,01
801529		[2.87] 72,9	[2.24] 56,9							
821512	8315, 8316	[2.75] 69,9	[2.00] 50,8	[0.75] 19,1	[0.57] 14,5	[0.38] 9,5	[0.75] 19,1	3/8-16	[0.38] 9,5	[0.05] 0,02
821513		[3.75] 95,3	[3.00] 76,2							

## Clamping Arm Adapters

### Features:

- For attaching custom made clamp arms
- 360° rotatable arm
- Aluminum construction

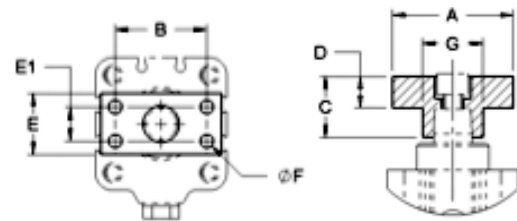
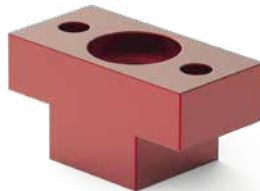

Part Number	Used with Model	A	B	C	D	E	E1	F	Weight [lbs] kg
801532	8115, 8116	[1.37] 34,8	[1.00] 25,4	[0.39] 9,1	[0.25] 6,4	[0.62] 15,7	--	#10-32 (2x)	[0.03] 0,014
821556	8315, 8316	[1.50] 38,1	[1.06] 26,9	[0.75] 19	[0.37] 9,4	[0.75] 19	--	1/4-20 (2x)	[0.05] 0,020

# 89E SERIES

## Pneumatic Swing Clamps | Product Overview

### Features:

- Lightweight and robust, designed for several millions cycles
- Threaded body may be mounted in a tapped hole or a clearance hole with optional mounting flange
- Metric design
- Clamp arm sold separately

### Applications:

- Assembly
- Welding
- Light machining

### Also Available:

See page MC-PSC-26 for clamping arms  
See page MC-PSC-27 for mounting flanges

### Series 89E



## Technical Information

Model	Swing Direction	Total Stroke [in]mm S	Stroke During Rotation [in]mm S1	Vertical Clamp Stroke [in]mm S2	Clamping Force [lbf.] N†	Bore Size mm[in]	Air Consumption‡ [ft³]dm³	Weight [lb.]kg	Replacement Seal Kit
89E20-010-2R	RH	[0.79]	[0.39]		[29]	[0.79]	[0.003]	[0.64]	89B/E20-2-00
89E20-010-2L	LH	20	10		130	20	0,08	0,29	
89E32-010-2R	RH	[0.83]	[0.43]	[0.39]	[79]	[1.25]	[0.008]	[0.93]	89B/E32-2-00
89E32-010-2L	LH	21	11	10	350	32	0,22	0,42	
89E40-010-2R	RH	[0.94]	[0.55]		[130]	[1.57]	[0.014]	[1.76]	89B/E40-2-00
89E40-010-2L	LH	24	14		580	40	0,39	0,80	
89E50-025-2R	RH	[1.57]	[0.59]	[0.98]	[225]	[1.97]	[0.036]	[3.22]	89B/E50-2-00
89E50-025-2L	LH	40	15	25	1000	50	1,03	1,46	
89E63-008-2R	RH	[1.02]	[0.71]	[0.32]	[321]	[2.48]	[0.038]	[3.68]	89B/E63-2-00
89E63-008-2L	LH	26	18	8	1430	63	1,08	1,67	

† with standard clamping arm at 6bar [87psi]. ‡ per double stroke at 6bar [87psi]

**Operating Pressure Range:** 3bar [45psig] to 10bar [145psig] (89E20 8bar [116psig] max.)

**Maximum Operating Temperature:** 80°C [176°F]

# 89E SERIES

## Pneumatic Swing Clamps | Dimensions

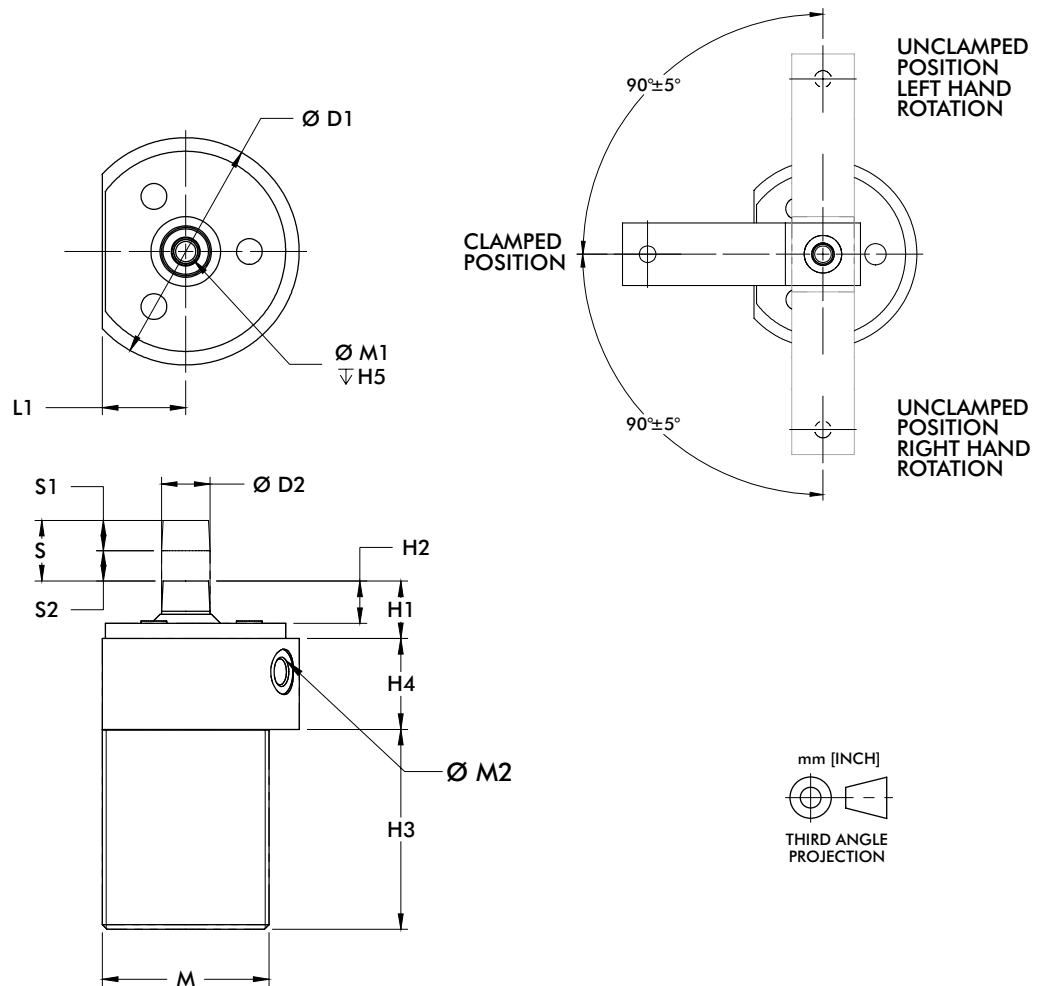

S = Total Stroke  
 S1 = Stroke during Rotation  
 S2 = Vertical Clamp Stroke

Model	ØD1	ØD2	H1	H2	H3	H4	H5	L1	M	M1	M2
89E20	[1.89] 48	[0.39] 10	[0.69] 17,5	[0.35] 9	[2.36] 60	[0.79] 20	[0.59] 15	[0.75] 19	M36X1,5	M5	M5
89E32	[2.52] 64	[0.47] 12	[0.63] 16	[0.43] 11	[2.72] 69		[0.67] 17	[0.89] 22,5	M42X1,5	M6	G-1/8
89E40	[2.95] 75	[0.63] 16	[0.75] 19	[0.55] 14	[2.60] 66	[1.18] 30	[0.98] 25	[1.08] 27,5	M55X2	M8	
89E50	[3.54] 90	[0.71] 18	[0.98] 25	[0.67] 17	[4.09] 104		[1.36] 34,5	M68X2	M10	G-1/4	
89E63	[4.13] 105	[0.79] 20	[1.06] 27	[0.75] 19	[3.03] 77	[1.57] 40	M80X2	M10			

### Mounting Options

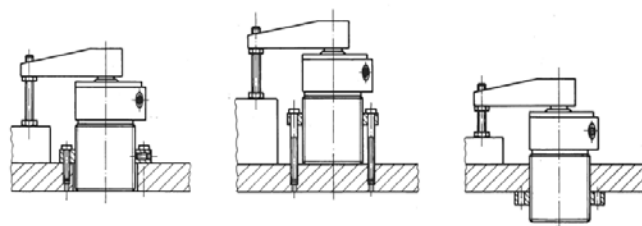

# 89E SERIES

## Pneumatic Swing Clamps | Clamping Forces

Series 89E Clamping Force  
(w/ standard clamping arm)

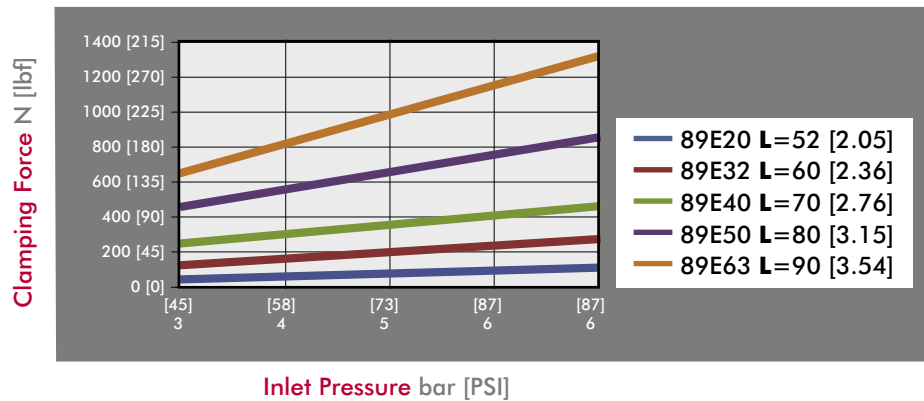

### Guidelines

DESTACO Pneumatic Swing Clamps are designed for long life when using standard clamping arms and spindles. In the event that a longer arm or additional weight is needed, please consult these charts for the allowable weight and length.

#### Example: 89E32

At a weight of 80 gr, the maximum length of the arm is approximately 90mm.

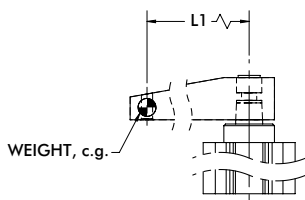

All data refers to an operating pressure of 5 bar [72psi] and an opening and closing time of 1 second.

89E20 & 89E32 Clamp Arm Weight

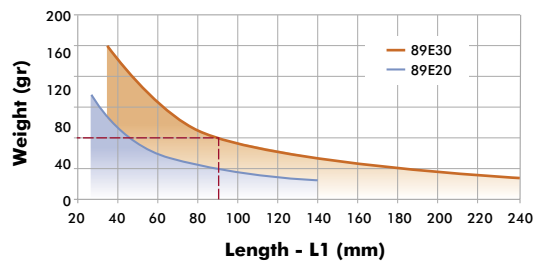

89E40 & 89E50 Clamp Arm Weight

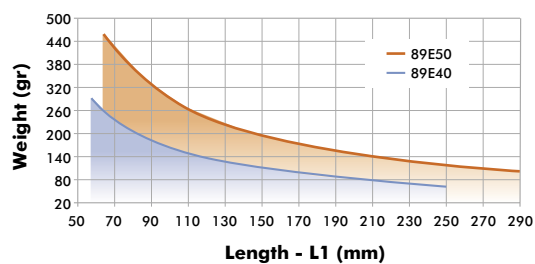

89E63 Clamp Arm Weight

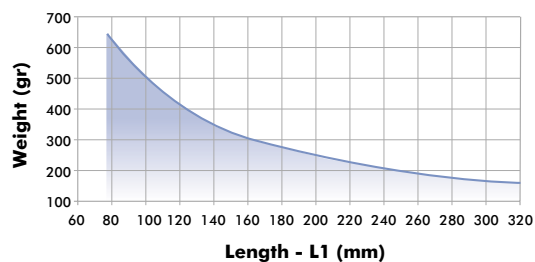

## Pneumatic Swing Clamps | Clamping Arms

### Features:

- Lightweight aluminum construction
- Locking tapered connection for 360 deg. arm positioning

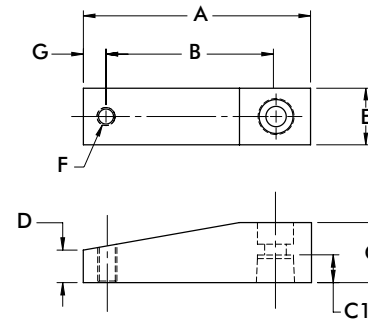

Part Number	Used with Model	A	B	C	C1	D	E	F	G	Weight [lbs] kg
8JG-215-1	89E20-010-2	[2.64] 67	[2.05] 52	[0.59] 15	[0.33] 8,5	[0.33] 8,5	[0.59] 15	M6	[0.28] 7	[0.08] 0,04
8JG-217-1	89E32-010-2	[3.15] 80	[2.36] 60	[0.79] 20	[0.37] 9,5		[0.79] 20	M8	[0.39] 10	[0.14] 0,06
8JG-218-1	89E40-010-2	[3.74] 95	[2.76] 70	[0.98] 25	[0.45] 11,5	[0.55] 14	[0.98] 25			[0.28] 0,13
8JG-219-1	89E50-025-2	[4.17] 106	[3.15] 80	[1.18] 30	[0.59] 15	[0.57] 14,5	[1.18] 30			[0.42] 0,19
8JG-220-1	89E63-008-2	[4.72] 120	[3.54] 90	[1.38] 35	[0.67] 17	[0.67] 17	[1.38] 35	M10	[0.47] 12	[0.66] 0,30

## Clamping Arm Adapters

### Features:

- For attaching custom made clamp arms
- 360° rotatable arm
- Aluminum construction

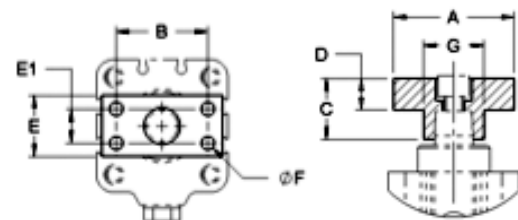
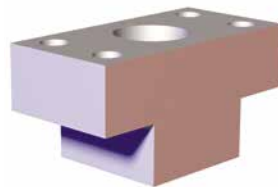

Part Number	Used with Model	A	B	C	D	E	E1	F	Weight [lbs] kg
8MA-084-1	89E20-010-2	[1.57] 40	[1.10] 28	[0.59] 15	[0.32] 8	[0.59] 15	--	[0.22] 5,5 (2x)	[0.03] 0,014
8MA-086-1	89E32-010-2	[1.97] 50	[1.38] 35	[0.79] 20	[0.43] 11	[0.79] 20	--	[0.22] 5,5 (4x)	[0.08] 0,035
8MA-087-1	89E40-010-2		[1.50] 38	[0.98] 25	[0.51] 13	[0.98] 25	[0.55] 14	[0.22] 7 (4x)	[0.11] 0,050
8MA-088-1	89E50-025-2	[2.36] 60	[1.77] 45	[1.18] 30	[0.59] 15	[1.18] 30	[0.59] 15	[0.28] 7 (4x)	[0.19] 0,085
8MA-089-1	89E63-008-2	[2.56] 65	[1.89] 48	[1.38] 35	[0.67] 17	[1.38] 35	[0.71] 18	[0.35] 9 (4x)	[0.28] 0,125

# 89E SERIES

## Pneumatic Swing Clamps | Mounting Flanges

### Features:

- For use with Threaded Body Pneumatic Swing Clamps
- Variable height adjustment
- For recessed mounting

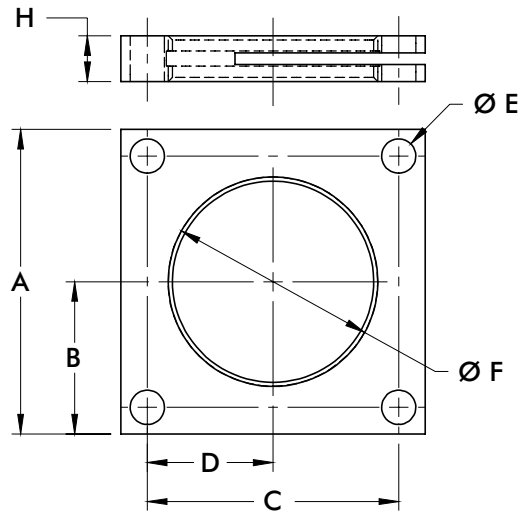
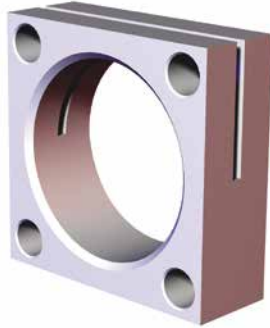

Part Number	Used with Model	A	B	C	D	E	F	H
8MA-219-1	89E20-010-2	[2.17] 55	[4.33] 27,5	[1.65] 42	[0.83] 21	[0.26] 6,6	M36X1,5	[0.31] 8
8MA-220-1	89E32-010-2	[2.76] 70	[1.38] 35	[2.13] 54	[1.06] 27	[0.35] 9	M42X1,5	[0.39] 10
8MA-221-1	89E40-010-2	[3.15] 80	[1.57] 40	[2.60] 66	[1.30] 33		M55X2	[0.47] 12
8MA-222-1	89E50-025-2	[3.54] 90	[1.77] 45	[2.99] 76	[1.50] 38	[0.43] 11	M68X2	[0.59] 15
8MA-223-1	89E63-008-2	[4.33] 110	[2.17] 55	[3.54] 90	[1.77] 45		M80X2	



# 8000, 8200, 8400 SERIES

## Pneumatic Swing Clamps | Product Overview

### Features:

- Threaded body may be mounted in a tapped hole or a clearance hole with optional mounting flange. 8215/8216 may be mounted with the upper flange.
- Sensor ready for use with round style sensors
- Clamp arm and spindle included

### Applications:

- Assembly
- Welding
- Light machining

### Also Available:

- See page MC-PSC-31 for clamping arms
- See page MC-PSC-31 for mounting flanges
- See page MC-PSC-40 for sensing options



## Technical Information

Model	Swing Direction	Total Stroke [in]mm	Stroke During Rotation [in]mm	Vertical Clamp Stroke [in]mm	Clamping Force [lbf.] N†	Bore Size [in]mm	Air Consumption‡ [ft³]dm³	Weight [lb.]kg	Replacement Seal Kit
8015	RH	[0.85]	[0.47]	[0.38]	[18]	[0.75]	[0.002]	[1.0]	801560
8016	LH	21,5	11,8	9,7	80	19,1	0,06	0,45	
8215	RH	[1.25]	[0.75]	[0.50]	[67]	[1.50]	[0.015]	[2.2]	821560
8216	LH				300	38,1	0,41	1	
8415	RH	31,8	19,1	12,7	[55]	[1.19]	[0.009]	[1.5]	841560
8416	LH				245	30,2	0,25	0,68	

† with standard clamping arm at 5bar [72psi]. ‡ per double stroke at 5bar [72psi]

**Operating Pressure Range:** 3bar [45psig] to 9bar [130psig]

**Maximum Operating Temperature:** 60°C [140°F]

### Note:

To order without clamping arm add **-LA** to the end of the model. Ex. 8215-**LA**



# 8000, 8200, 8400 SERIES

## Pneumatic Swing Clamps | Dimensions

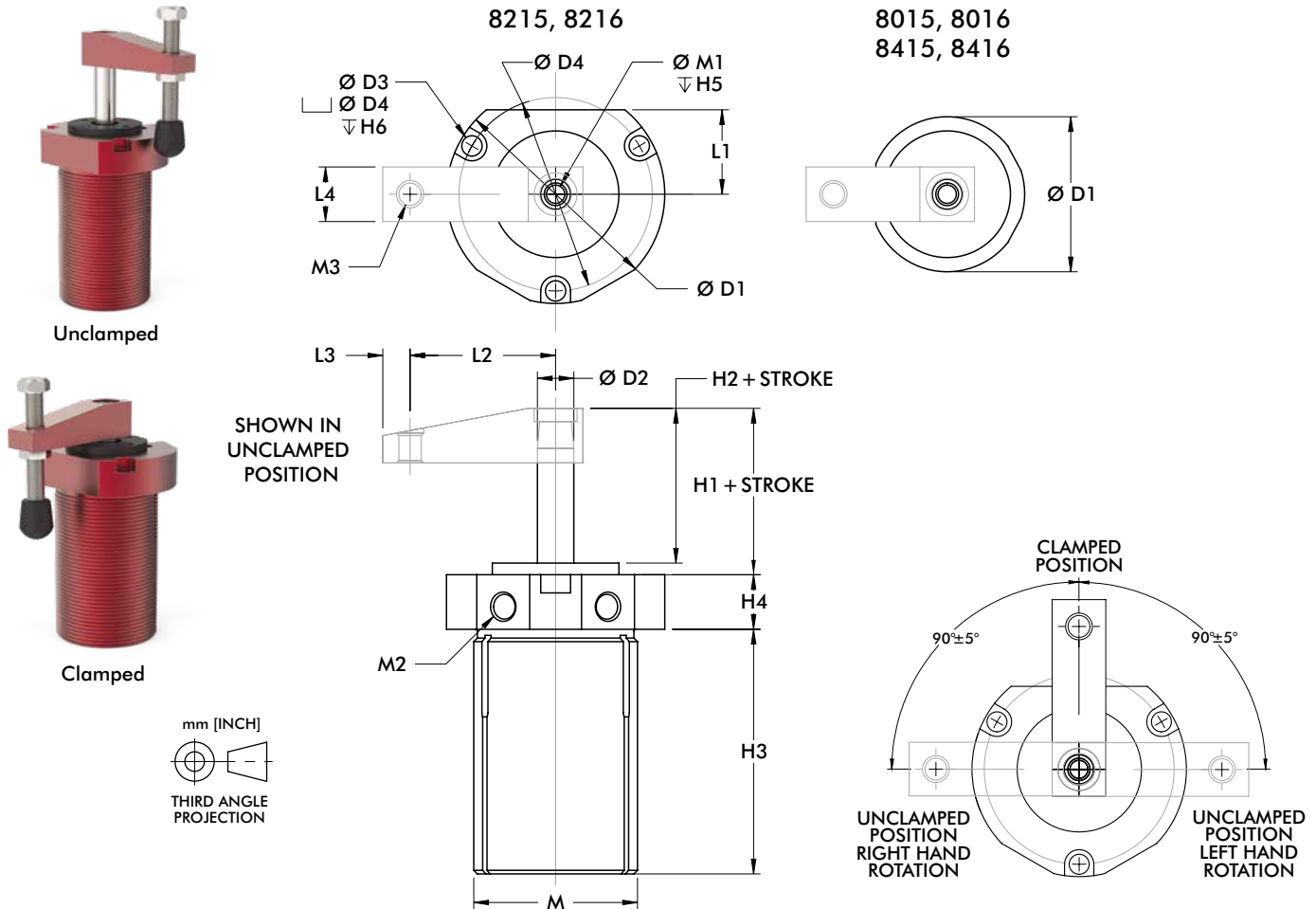

mm [INCH]  
THIRD ANGLE PROJECTION

Model	ØD1	ØD2	ØD3	ØD4	Stroke	H1	H2	H3	H4	H5	H6	L1
8015	[1.25]	[0.44]	--	--	[0.85]	[0.53]	[0.41]	[2.87]	[0.50]	[0.75]	--	--
8016	31,8	11,1	--	--	21,5	13,5	10,4	72,9	12,7	19,1	--	--
8215	[3.00]	[0.50]	[0.28]	[2.66]	[1.25]	[0.97]	[0.81]	[3.36]	[0.75]	[0.67]	[0.25]	[1.16]
8216	76,2	[0.50]	7,1	67,6	31,8	24,6	20,6	85,3	[0.75]	17	6,4	29,5
8415	[2.13]	12,7	--	--	[0.94]	[0.94]	[0.78]	[3.17]	19,1	--	--	--
8416	54,1	--	--	--	23,9	23,9	19,8	80,5	--	--	--	--

Model	L2	L3	L4	M	M1	M2	M3
8015	[1.12]	[0.31]	[0.62]	1-1/8-16	1/4-20	#10-32	#10-32
8016	28,4	7,9	15,7				
8215	[2.00]	[0.38]	[0.75]	2-1/4-12	5/16-18	1/8 NPT	3/8-16
8216	50,8	9,6	19,1				
8415	[1.56]			1-3/4-12			
8416	39,6						

### Mounting Options

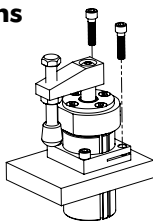

**8000, 8200, 8400**  
Mounted into a tapped hole or a through a clearance hole with the optional mounting flange. Jam nuts are available for 8000.

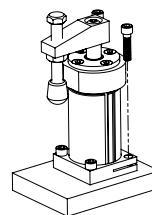

**8200 only**  
Mounted through a clearance hole using mounting screws in the top flange.

# 8000, 8200, 8400 SERIES

## Pneumatic Swing Clamps | Clamping Forces

Series 8000, 8200, 8400 Clamping Force  
(w/ standard clamping arm)

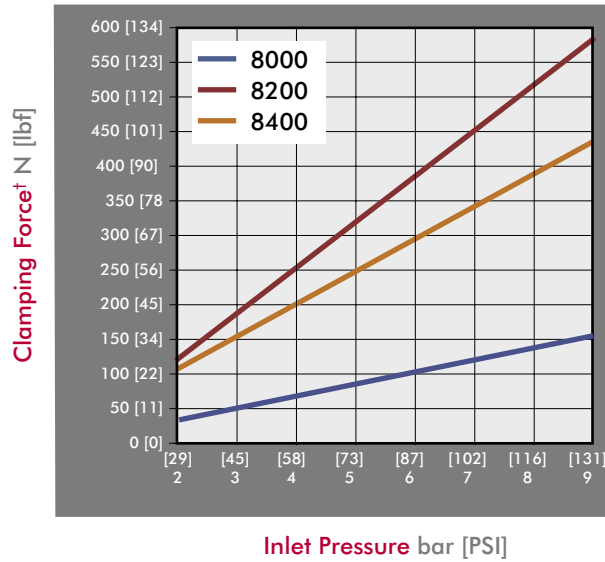

## Guidelines

DESTACO Pneumatic Swing Clamps are designed for long life when using standard clamping arms and spindles. In the event that a longer arm or additional weight is needed, please consult these charts for the allowable weight and length.

### Example: 8215

At a weight of 80 gr, the maximum length of the arm is approximately 90mm.

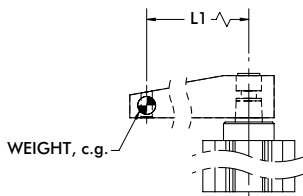

All data refers to an operating pressure of 5 bar [72psi] and an opening and closing time of 1 second.

8015/8016 Clamp Arm Weight

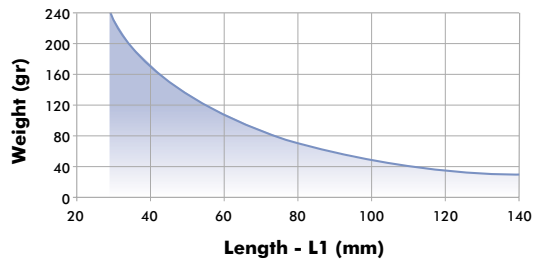

8215/8216 Clamp Arm Weight

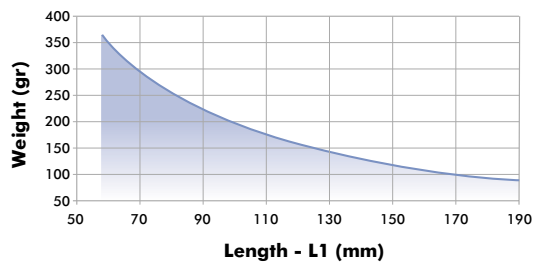

8415/8416 Clamp Arm Weight

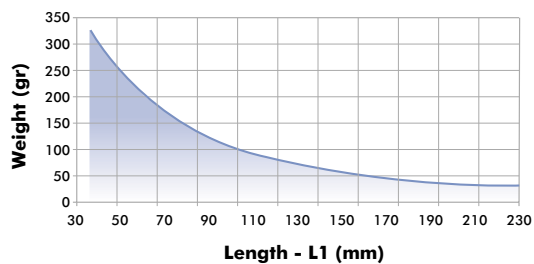

# 8000, 8200, 8400 SERIES

## Pneumatic Swing Clamps | Clamping Arms

### Features:

- Lightweight aluminum construction
- Locking tapered connection for 360 deg. arm positioning

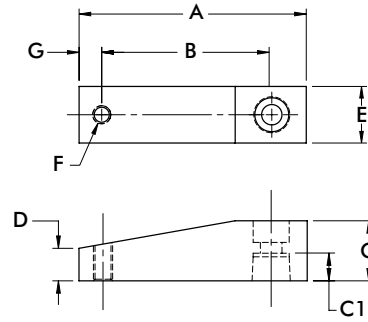
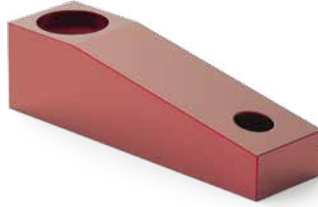

Part Number	Used with Model	A	B	C	C1	D	E	F	G	Weight [lbs] kg
801528	8015, 8016	[1.74] 44,2	[1.11] 28,2	[0.37] 9,4	[0.33] 8,3	[0.25] 6,4	[0.62] 15,7	#10-32	[0.32] 8,1	[0.03] 0,01
801529		[2.87] 72,9	[2.24] 56,9							
821512	8215, 8216, 8415, 8416	[2.75] 69,9	[2.00] 50,8	[0.75] 19,1	[0.57] 14,5	[0.38] 9,5	[0.75] 19,1	3/8-16	[0.38] 9,5	[0.04] 0,02
821513		[3.75] 95,3	[3.00] 76,2							

## Clamping Arm Adapters

### Features:

- For attaching custom made clamp arms
- 360° rotatable arm
- Aluminum construction

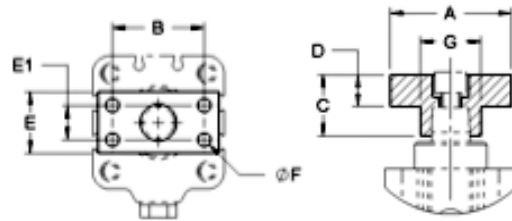

Part Number	Used with Model	A	B	C	D	E	E1	F	Weight [lbs] kg
801532	8015, 8016	[1.37] 34,8	[1.00] 25,4	[0.39]	[0.25]	[0.62]	--	#10-32 (2x)	[0.03] 0,014
821556	8215, 8216	[1.50] 38,1	[1.06] 26,9	[0.75]	[0.37]	[0.75]	--	1/4-20 (2x)	[0.05] 0,020

## Mounting Flanges

### Features:

- For use with Threaded Body Pneumatic Swing Clamps
- Variable height adjustment
- For recessed mounting

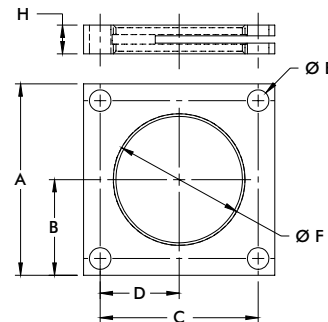

Part Number	Used with Model	A	B	C	D	E	F	H
801553	8015, 8016	[1.38] 35	[0.69] 17,5	[1.08] 27,4	[0.54] 13,7	[0.20] 5,1	1 1/8-16	[0.50] 12,7
821553	8215, 8216	[2.50] 63,5	[1.25] 31,8	[2.12] 53,8	[1.06] 26,9	[0.28] 7,1	2 1/4-12	
841550	8415, 8416	[2.00] 50,8	[1.00] 25,4	[1.60] 40,6	[0.80] 20,3		1 3/4-12	

### Features:

- Available with threaded body, or lower flange mounting
- Low profile for confined spaces
- Double locked arm attachment is bolted to piston rod and clamped around shaft diameter

### Applications:

- Assembly
- Welding
- Light machining

### Also Available:

See page MC-PSC-35 for clamping arms  
See page MC-PSC-36 for jam nuts

### Series 035-1



Threaded body design for mounting through fixture plates.

### Series 035-2



Flanged body design for quick and easy mounting

## Technical Information

Model	Swing Direction	Total Stroke [in]mm S	Stroke During Rotation [in]mm S1	Vertical Clamp Stroke [in]mm S2	Clamping Force [lbf.] N†	Bore Size [in]mm	Air Consumption‡ [ft³]dm³	Weight [lb.]kg	Replacement Seal Kit
035-125-190	RH	[1.04]	[0.51]	[0.53]	[20]	[0.98]	[0.005]	[0.56]	905516
035-125-290	LH	26,3	12,8	13,5	89	25	0,13	0,25	
035-132-190	RH	[1.13]	[0.56]	[0.57]	[30]	[1.26]	[0.008]	[0.94]	905517
035-132-290	LH	28,8	14,3	14,5	133	32	0,24	0,43	
035-140-190	RH	[1.20]	[0.57]	[0.63]	[60]	[1.57]	[0.015]	[1.31]	905518
035-140-290	LH	30,4	14,4	16	267	40	0,41	0,59	
035-150-190	RH	[1.18]	[0.63]	[0.55]	[69]	[1.97]	[0.023]	[1.81]	905519
035-150-290	LH	30	16	14	307	50	0,64	0,82	
035-225-190	RH	[1.05]	[0.54]	[0.51]	[20]	[0.98]	[0.005]	[0.56]	905516
035-225-290	LH	26,7	13,7	13	89	25	0,13	0,25	
035-232-190	RH	[1.06]	[0.57]	[0.49]	[30]	[1.26]	[0.008]	[1.13]	905517
035-232-290	LH	26,8	14,4	12,4	133	32	0,24	0,51	
035-240-190	RH	[1.09]	[0.57]	[0.52]	[60]	[1.57]	[0.015]	[1.40]	905518
035-240-290	LH	27,7	14,4	13,3	267	40	0,41	0,64	
035-250-190	RH	[1.13]	[0.63]	[0.51]	[69]	[1.97]	[0.023]	[1.90]	905519
035-250-290	LH	28,8	16	12,8	307	50	0,64	0,86	

† with standard clamping arm at 5bar [72psi]. ‡ per double stroke at 5bar [72psi]

**Operating Pressure Range:** 3bar [45psig] to 7bar [100psig]

**Maximum Operating Temperature:** 80°C [176°F]

# 035 SERIES

## Pneumatic Swing Clamps | Dimensions



Series 035-1

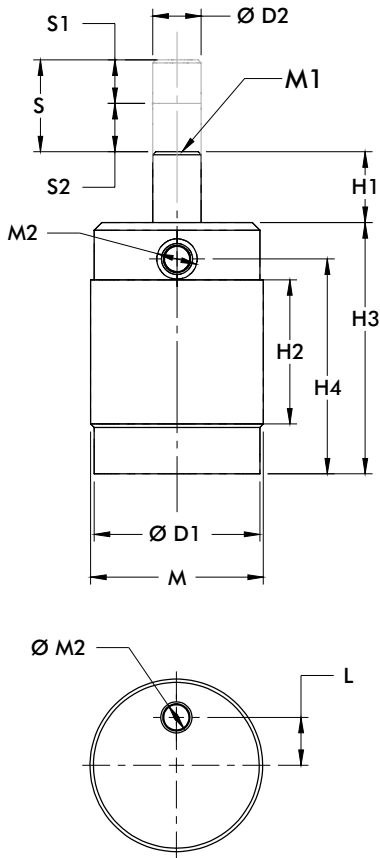

Series 035-2

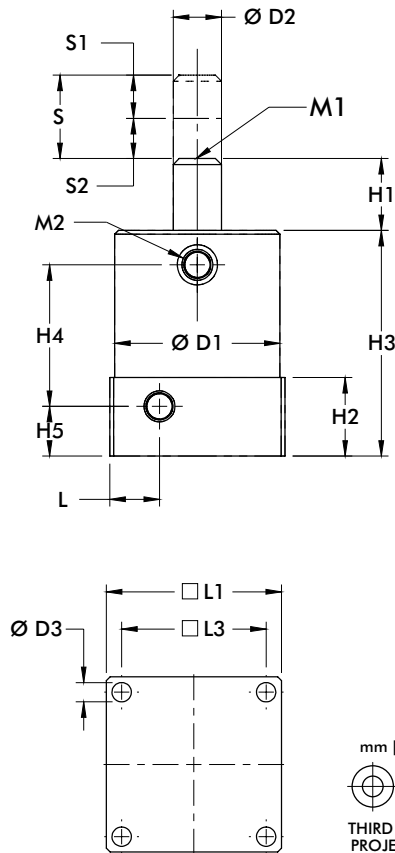

## Mounting Options

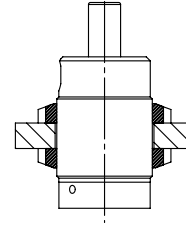

**035-1**  
Threaded body mounts through a clearance hole and locked in place using two optional jam nuts

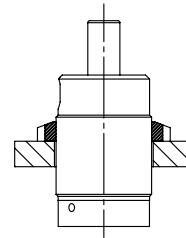

**035-1**  
Threaded body mounts into a threaded hole and is locked in place using one optional jam nuts

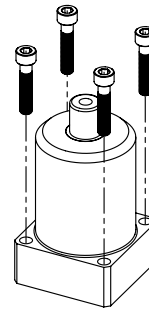

**035-2**  
Mount using four mounting holes in the base flange

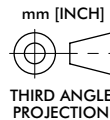

THIRD ANGLE PROJECTION

Model	ØD1	ØD2	D3	H1	H2	H3	H4	H5	L	L1	L3	M	M1	M2
035-125-( )	[1.42] 36	[.55] 14	--	[0.57] 14,4	[1.50] 38,1	[2.76] 70	[2.25] 57,2	--	[0.35] 9	--	--	1-½ -16	1/4-20	#10-32
035-132-( )	[1.79] 45,4	[0.63] 16	--	[0.75] 19,1	[1.72] 43,7	[3.87] 98,2	[2.63] 66,7	--	[0.45] 11,4	--	--	1-7/8-16	5/16-18	1/8 NPT
035-140-( )	[2.16] 54,8	[0.79] 20	--	[0.76] 19,4	[1.88] 47,7	[3.28] 83,2	[2.80] 71	--	[0.70] 17,8	--	--	2-1/4-16		
035-150-( )	[2.36] 60	[0.79] 20	--	[0.70] 17,8	[2.00] 50,8	[3.48] 88,3	[2.95] 75	--	[0.50] 12,7	--	--	2-1/2-16	3/8-16	
035-225-( )	[1.38] 35	[.55] 14	[.18] 4,5	[0.60] 15,2	[.91] 23	[2.62] 66,5	[1.60] 40,6	[0.50] 12,7	[0.57] 14,5	[1.57] 40	[1.22] 31	--	1/4-20	#10-32
035-232-( )	[1.97] 50	[0.63] 16	[.26] 6,5	[0.85] 21,6	[1.03] 26,1	[2.79] 71	[1.76] 44,6	[0.57] 14,5	[0.65] 16,5	[2.13] 54	[1.73] 44	--	5/16-18	1/8 NPT
035-240-( )	[2.16] 54,8	[0.79] 20	[.33] 8,5	[0.94] 23,9	[1.03] 26,1	[2.95] 75	[1.85] 47	[0.65] 16,5	[0.65] 16,5	[2.29] 58,2	[1.89] 48	--		
035-250-( )	[2.36] 60	[0.79] 20	[.33] 8,5	[0.78] 19,7	[1.03] 26	[3.15] 80	[2.05] 52	[0.65] 16,5	[0.65] 16,5	[2.68] 68	[2.17] 55	--	3/8-16	

Series 035 Clamping Force  
(w/ standard clamping arm)

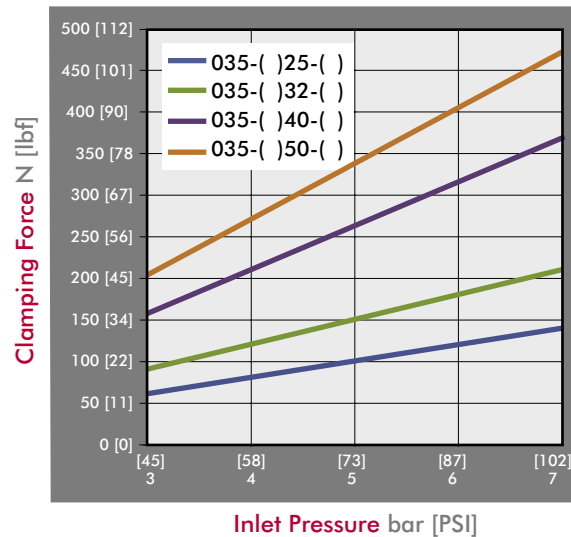

### Guidelines

DESTACO Pneumatic Swing Clamps are designed for long life when using standard clamping arms and spindles. In the event that a longer arm or additional weight is needed, please consult these charts for the allowable weight and length.

**Example: 035-132-190**

At a weight of 80 gr, the maximum length of the arm is approximately 90mm.

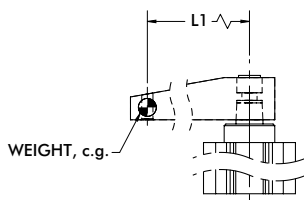

All data refers to an operating pressure of 5 bar [72psi] and an opening and closing time of 1 second.

25mm, 32mm Clamp Arm Weight

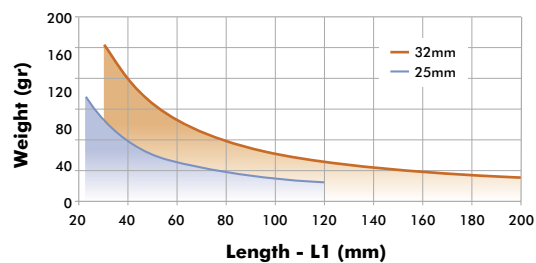

40mm, 50mm Clamp Arm Weight

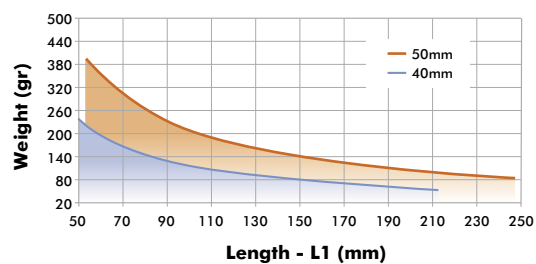

# 035 SERIES

## Pneumatic Swing Clamps | Clamping Arms

### Features:

- For standard use
- Aluminum construction
- Clamp on style connection for 360 deg. arm positioning



036-XXX-02

036-XXX-01

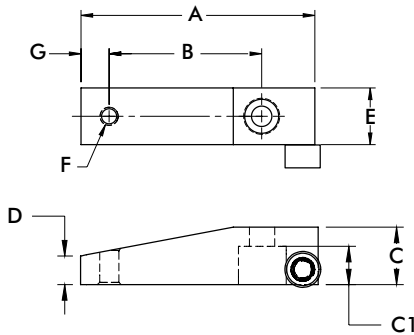

Part Number	Used with Model/series	A	B	C	C1	D	E	F	G	Weight [lbs] kg
036-551-01	035-12.... 035-22....	[2.38] 60,5	[1.36] 34,5	[0.63] 15,9	[0.40] 10,2	[0.31] 8	[0.75] 19,1	1/4-20	[0.32] 8	[0.10] 0,05
036-551-02		[3.38] 85,9	[2.36] 60							[0.13] 0,06
036-630-01	035-13.... 035-23.... 035-14.... 035-24....	[3.10] 78,7	[2.00] 50,8	[0.75] 19,1	[0.50] 12,7	[0.38] 9,5	[0.75] 19,1	5/16-18	[0.38] 9,5	[0.15] 0,07
036-630-02		[4.73] 120	[3.63] 92,1							[0.21] 0,10
036-787-01	035-15.... 035-25....	[4.00] 101,6	[2.75] 69,9	[1.00] 25,4	[0.70] 17,8	[0.50] 12,7	[1.00] 25,4	3/8-16	[0.38] 9,5	[0.33] 0,15
036-787-02		[6.36] 161,5	[5.00] 127							[0.49] 0,22



# 035 SERIES

## Pneumatic Swing Clamps | Jam Nuts

### Features:

- For use with Threaded Body Pneumatic Swing Clamps
- Variable height adjustment
- For recessed mounting
- Steel construction

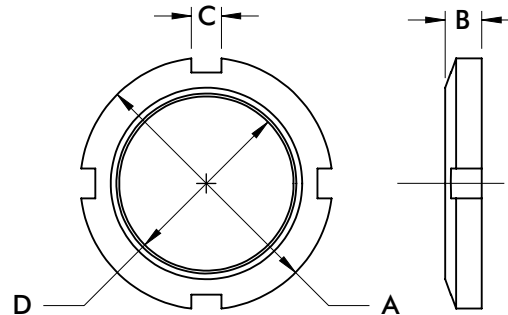

Part Number	Used with Model/series	A	B	C	D	Weight [lbs] kg
051-150-160	035-125-190, 035-125-290	[2.00] 50.8	[0.38] 9.7	[0.275] 7.0	1 1/2-16 UN	[0.13] 0.06
051-187-160	035-132-190, 035-132-290	[2.63] 66.7				[0.25] 0.11
051-225-160	035-140-190, 035-140-290	[3.00] 76.2	[0.50] 12.7	[0.312] 7.9	2 1/4-16 UN	[0.40] 0.18
051-250-160	035-150-190, 035-150-290	[3.25] 82.6				[0.44] 0.20

# 8700 SERIES

## Pneumatic Lever Clamps | Product Overview

### Features:

- Alternative solution to swing clamps when space is limited
- The clamping lever may be positioned left, forward, or right (relative to ports) within the same clamp body
- Threaded body with upper flange mount
- Non-toggle locking linkage
- Clamping arm and spindle included

### Applications:

- Assembly & welding fixtures
- Light machining

### Also Available:

See page MC-PSC-39 for jam nuts

8725



8732  
8732G



8740  
8740G



8750  
8750G



## Technical Information

Model	Vertical Clamping Stroke* [in.] mm	Clamping Force† [lb.f.] N	Bore Size [in.] mm	Air Consumption‡ [in. <sup>3</sup> ] cm <sup>3</sup>	Weight [lb.] kg	Seal Kit
8725	[0.10] 2,5	[43] 195	[0.98] 25	[0.004] 0,11	[1.3] 0,6	872500
8732 8732G	[0.12] 3,2	[64] 285	[1.26] 32	[0.008] 0,23	[2.2] 1	873200
8740 8740G		[106] 470	[1.57] 40	[0.014] 0,41	[2.6] 1,2	874000
8750 8750G	[0.15] 3,8	[167] 745	[1.97] 50	[0.023] 0,64	[4,4] 2	875000

\* Equal to approx. 6° above horizontal with standard clamping arm. † at 5bar [72psi].

‡ per double stroke at 5bar [72psi].

### Operating Pressure Range:

3bar [45psig] to 7bar [100psig]

### Max. Operating Temperature:

-10°C to 80°C [14°F to 175°F]

### Application Note:

If using clamping arms other than standard, the length must not exceed 1.5X the overall length of the standard arm.

The inlet air flow rate should be adjusted to position the arm in no less than 1/2 second for standard arms and no less than 1 second in the case of an extended arm.

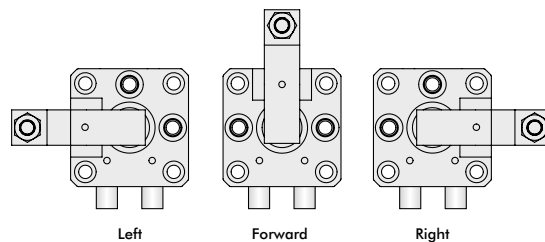

Levers can be positioned in one of three positions in relation to the air ports.

# 8700 SERIES

## Pneumatic Lever Clamps | Dimensions, Clamping Forces

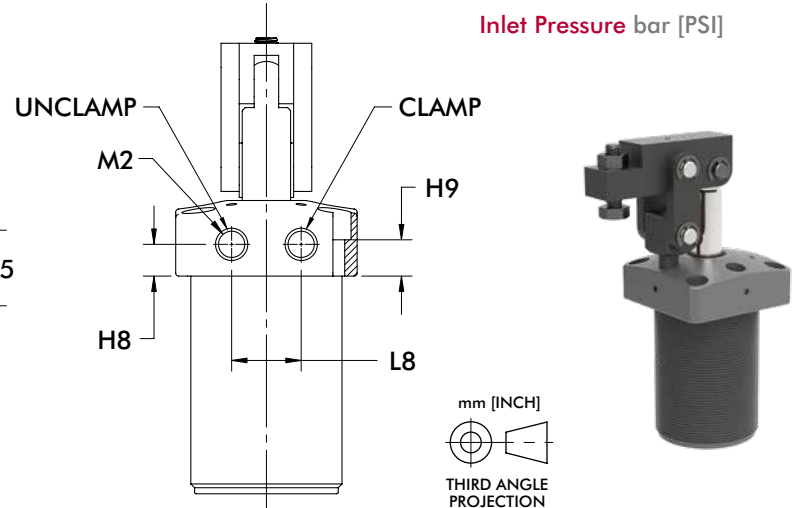
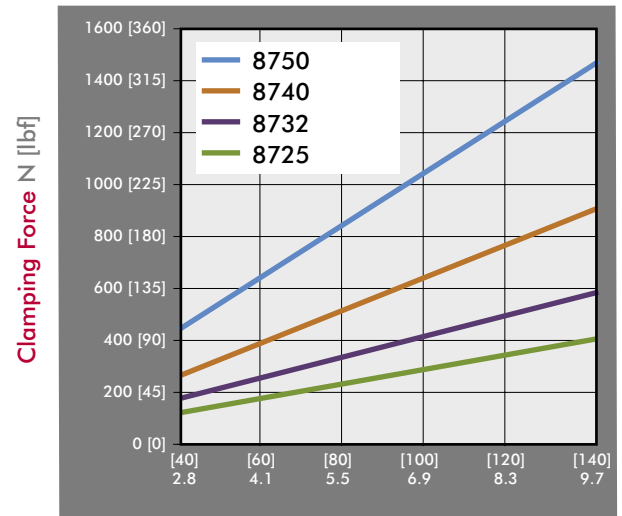
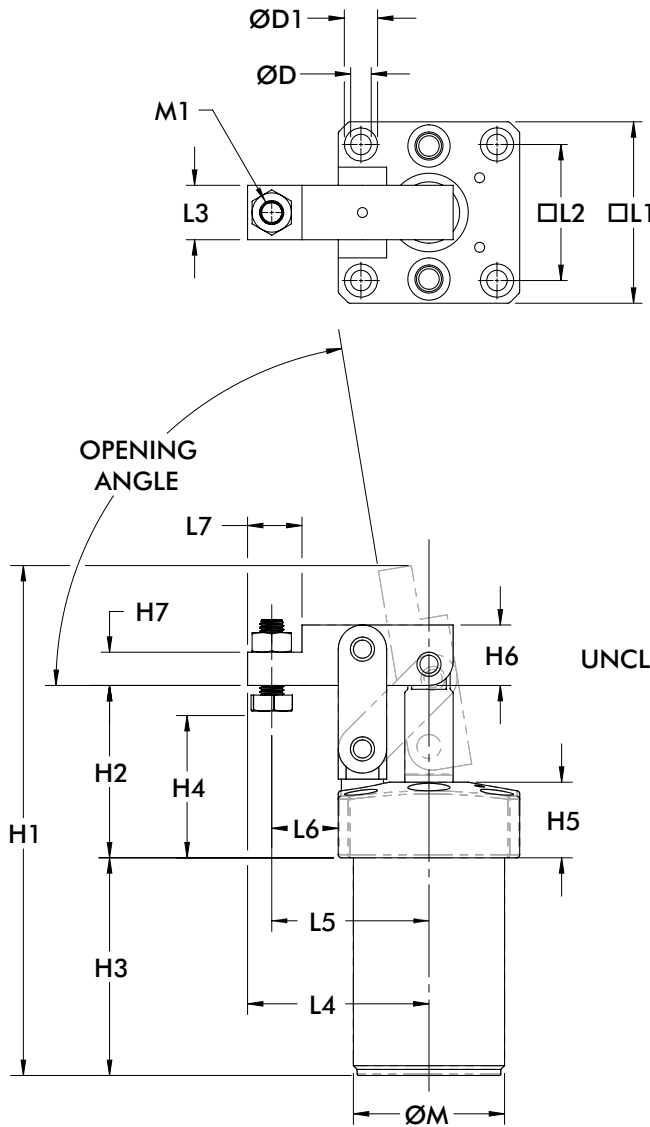

Model	Opening Angle	ØD	ØD1	H1	H2	H3	H4 (min/max)	H5	H6	H7	H8	H9
8725	80°	[0.22] 5,5	[0.35] 9	[5.67] 144	[1.97] 50	[2.42] 61,5	[0.59-0.98] 15-25		[0.67] 17	[0.39] 10	[0.47] 12	[0.59] 15
8732/ 8732G	81°	[0.27] 6,8	[0.43] 11	[6.65] 169	[2.25] 57	[2.83] 72	[0.63-1.18] 16-30	[0.98] 25	[0.79] 20	[0.43] 11		[0.51] 13
8740/ 8740G	82°	[0.27] 6,8	[0.43] 11	[6.93] 176	[2.40] 61	[2.85] 72,5	[0.75-1.14] 19-29		[0.98] 25	[0.55] 14	[0.41] 10,5	
8750/ 8750G	75°	[0.33] 8,5	[0.55] 14	[7.87] 200	[2.60] 66	[3.11] 79	[0.86-1.30] 22-33		[1.18] 30	[0.59] 15		[0.43] 11

Model	L1	L2	L3	L4	L5	L6	L7	L8	ØM	M1	M2
8725	[1.97] 50	[1.46] 37	[0.63] 16	[1.89] 48	[1.61] 41	[0.63] 16	[0.55] 14	[0.91] 23	M40 x 1.50	M6 x 1.0	M5 x 0.8
8732 8732G	[2.36] 60	[1.77] 45	[0.71] 18	[2.36] 60	[2.05] 52	[0.87] 22	[0.71] 18		M50 x 1.50	M8 x 1.25	[1/8NPT] G-1/8
8740 8740G	[2.65] 65	[1.97] 50	[0.79] 20	[2.60] 66	[2.20] 56	[0.93] 23,5	[0.79] 20	[1.02] 26	M55 x 1.50		[1/8NPT] G-1/8
8750 8750G	[2.95] 75	[2.28] 57	[0.87] 22	[3.05] 77,5	[2.50] 63,5	[1.02] 26	[1.10] 28	[1.26] 32	M65 x 1.50	M12 x 1.75	[1/8NPT] G-1/8

# 8700 SERIES

## Pneumatic Lever Clamps | Jam Nuts

### Features:

- For use with 8700 Series Pneumatic Lever Clamps
- Variable height adjustment
- For recessed mounting

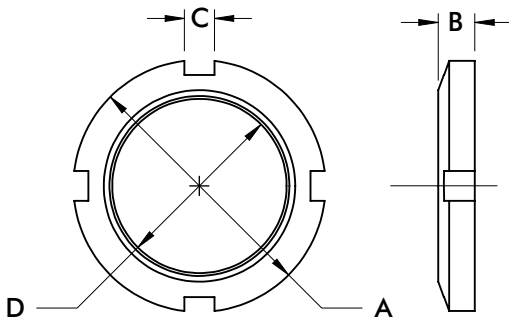

Mounting from above using 4 socket cap screws through the flange.

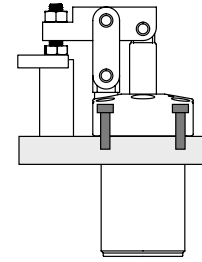

Mounting by screwing body into a tapped hole and locking with one jam nut.

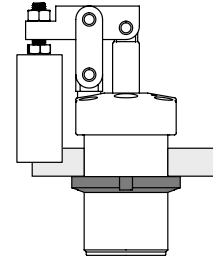

Mounting by inserting body into a plain hole and locking with two jam nuts.

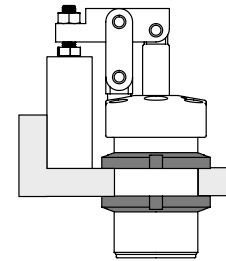

Part Number	Used with Model	A	B	C	D	Weight [lbs] kg
872550	8725	[2.28] 58	[0.35] 9	[0.28] 7	M40 x 1.50	[0.13] 0.06
873250	8732	[2.76] 70	[0.43] 11		M50 x 1.50	[0.35] 0.16
874050	8740	[2.95] 75		[0.31] 8	M55 x 1.50	[0.37] 0.17
875050	8750	[3.35] 85	[0.47] 12		M65 x 1.50	[0.33] 0.15

# PNEUMATIC SWING CLAMPS ACCESSORIES

Pneumatic Swing Clamps | Sensors

## Features:

- Sensors are activated by a magnetic ring installed on the cylinder piston
- All sensors feature an LED for easy set-up
- IP67 rated
- Temperature Range: -10°C to 60°C [14°F to 140°F]

810169,  
810173,  
810174



8EA-109-1,  
8EA-120-1,  
810170,  
810171



810151,  
810153,  
810155,  
810157



Tie rod clip 810151-1 included.

810156,  
810158



810153



## Technical Information

Item Number	Mount Style	Connector	Length	Function	Voltage	Max. Switching Current	Voltage Drop
810169	Round	M8 male quick connect	165mm [6.5in.]	Reed	5-120V AC/DC	50mA	3.0V
810173				PNP	4.5-28V DC	100mA	0.5V
810174				NPN	4.5-28V DC	100mA	0.5V
8EA-109-1	T-slot	M8 male quick connect	300mm [11.8in.]	Reed	10-30V DC	100mA	3.0V
8EA-120-1		M12 male quick connect	300mm [11.8in.]	Reed	15-30 V AC/DC	500mA	1.5V
810170		M8 male quick connect	165mm [6.5in.]	PNP	10-30V DC	100mA	2.0V
810171				NPN	10-30V DC	100mA	2.0V
810151	Tie Rod	No connector cord	2.7m [9ft.]	Reed	5-120V AC/DC	500mA	3.5V
810153				Reed	24-240V AC	4A	1.0V
810155				PNP	6-24V DC	500mA	1.0V
810157				NPN	6-24V DC	500mA	1.0V
810156	Band Clamp			Reed	5-120V AC/DC	500mA	3.5V
810158				PNP	6-24V DC	500mA	1.0V

# PNEUMATIC SWING CLAMPS ACCESSORIES

## Pneumatic Swing Clamps | Extension Cordsets

### Features:

- For use with M8 quick connect sensors
- Threaded coupling nuts provide IP67 protection
- Robotic grade, oil and abrasion resistant polyurethane (PUR) cable



Item Number	Length	Rating	Temperature Rating
CABL-010	2 Meter [78in.]	120V AC/DC, 3A max.	-20°C to 80°C [-40°F to 176°F]
CABL-013	5 Meter [16.4ft.]		

### Wiring Schematics

810169

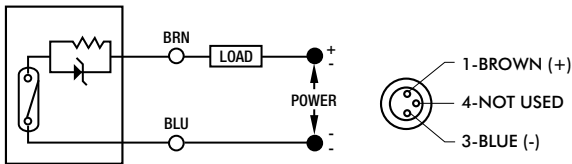

810170, 810173

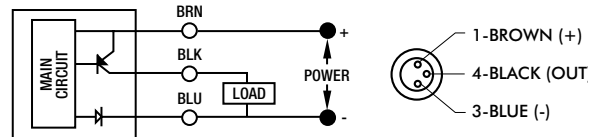

810171, 810174

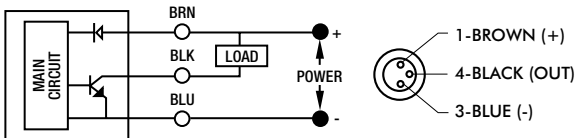

8EA-109-1, 8EA-120-1

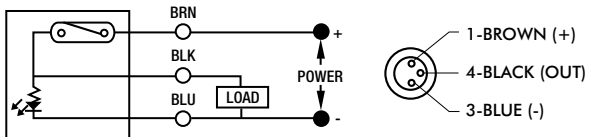

810153

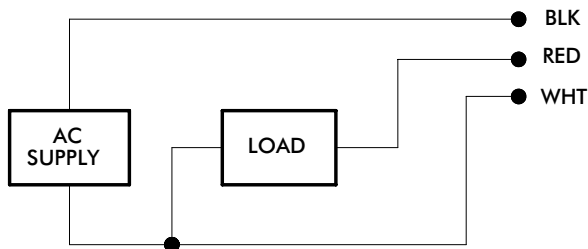

810151, 810156

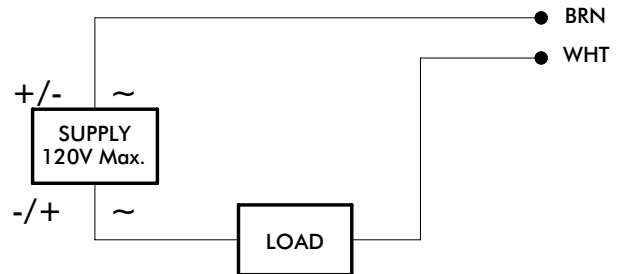

810155, 810158

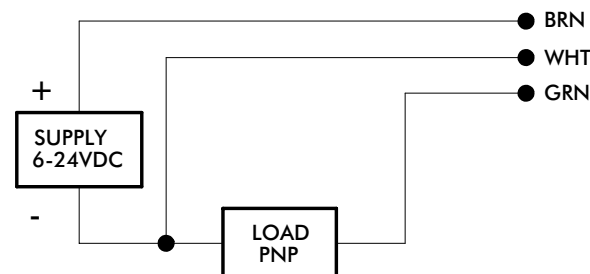

810157, 810158

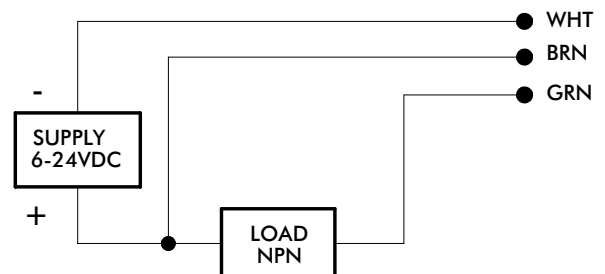

# 6004-SW SERIES

## Manual Swing Clamps | Product Overview and Dimensions

### Features:

- Left or right swing motion available
- 90° Swing clamp arm motion
- Higher clamping force than pneumatic version
- Though-hole mounting
- Clamp arm can be radially positioned 360°
- Handle can be radially positioned up to 180°

### Applications:

- Assembly
- Checking fixtures
- Welding fixtures
- Tensioning devices

### 6004-SWL

Clamp Arm  
Swing Left



### 6004-SWR

Clamp Arm  
Swing Right

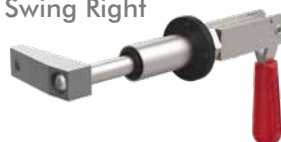

Shown in open (un-clamp) position.

## Technical Information | Holding Capacities | Dimensions

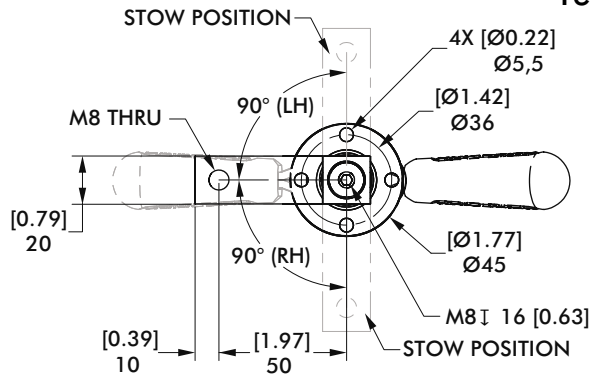

Model	Swing Direction	Total Stroke [in] mm	Stroke During Rotation [in] mm	Stroke Straight Pull [in] mm	Weight [lb] Kg
6004-SWL	LH	[1.50] 38	[0.87] 22	[0.63] 16	[1.32] 0,6
6004-SWR	RH	[1.50] 38	[0.87] 22	[0.63] 16	[1.32] 0,6

Applied Force (on handle) [lbs] N	[40] 178	[30] 133	[20] 89	[10] 44
Plunger Pull Force (straight pull)	[576] 2562	[432] 1922	[288] 1281	[144] 641
Clamp Force (with arm shown below)	[323] 1437	[269] 1197	[189] 841	[108] 480

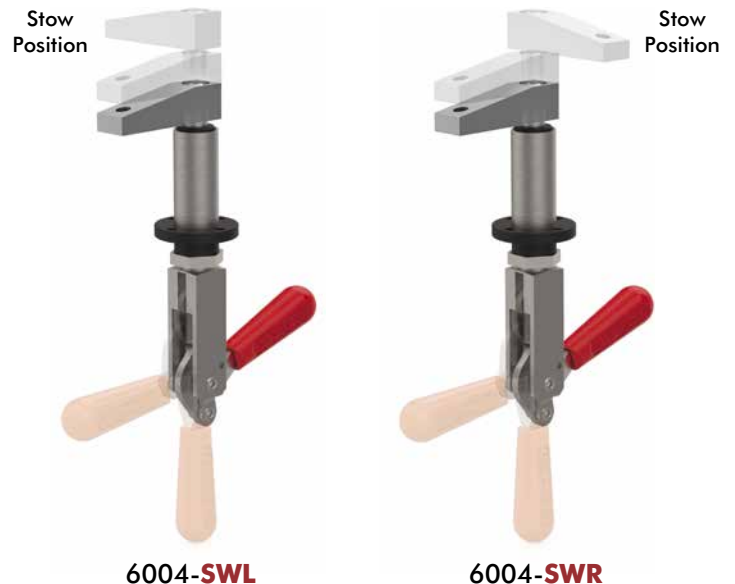
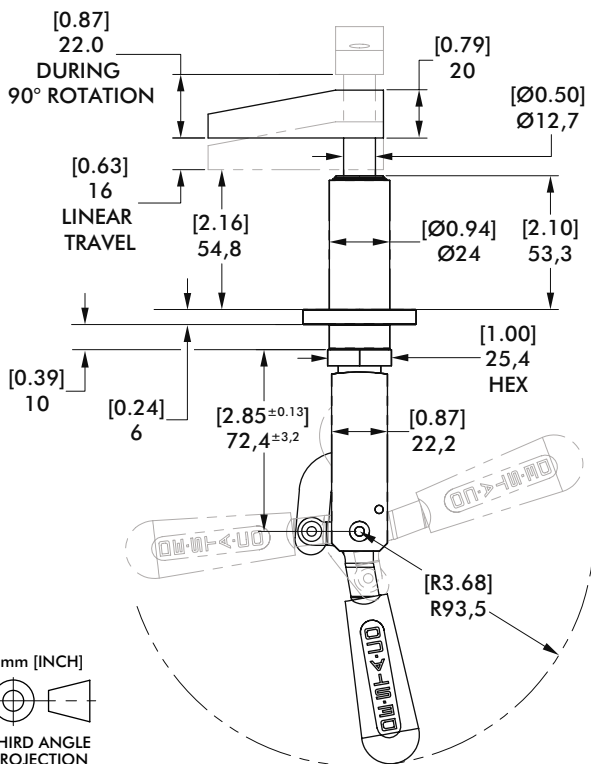

# PNEUMATIC POWER CYLINDERS

## Features

### Your requirements

Power element of machines, tools and devices for the following applications:

- Clamping
- Coining
- Punching
- Riveting
- Stamping
- Pressing
- Notching
- Clinching

### The solution

DESTACO's double acting power cylinder, which is based on the wedge lever principle.

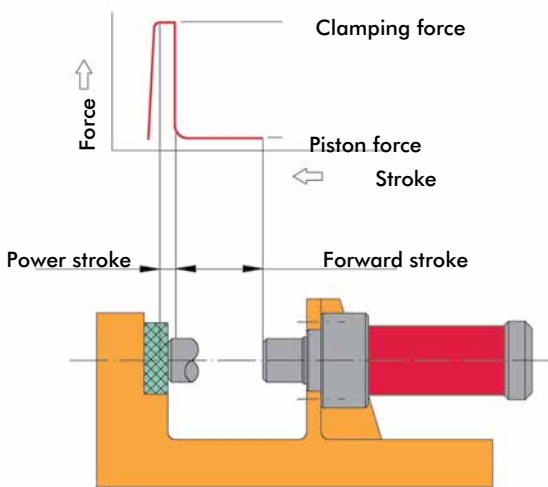

### Product features

- Mechanical advantage: 10:1
- Characteristic are the two steps of stroke: the forward stroke to move a certain distance and the power stroke with an amplified force on a short distance
- Exact positioning of cylinder by flange mount on cylinder's head
- Cylinder works in any position
- High durability because of solid and maintenance free wedge lever mechanics.
- End position control by magnetic field sensing

Technical Data	
Power forces at 6 bar	4 – 60 kN
Forward strokes	15 – 200 mm
Power strokes	6 and 7 mm*
Air pressure	max. 6 bar, min 3 bar
Mechanical advantage	max. 10:1
Cylinders require clean, water- and oil free air	

\*power strokes up to max. 12 mm upon request

### Round design: Type K and WK

- Piston rod with male thread (Type K) or ISO fit (Type WK)



### Rectangular design: Type WR

- Two piston rods prevent twisting

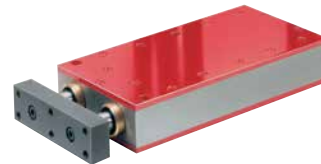

### Application Recommendations

- Compressed air should be treated by filter, water separator and pressure regulator. Oiler is not allowed!
- For an adequate piston speed air hoses with 6mm I.D. should be used.
- Do not increase the max. air pressure of 6 bar, because this would reduce the cylinder's life cycle considerably.
- The piston rods of type K and WK are not secured against twisting, an external device should be provided.
- Piston rod should not be subjected to transversal forces. Force should always be exerted by coaxial force through the piston rod to the work piece.
- For Type WR, force must be transmitted via the centre of the pressure plate.
- Connection between rod and tool should be performed as frictional connection (coupling), not as form fitting connection.
- For punching operations we recommend a force reserve of approx. 30 %.
- If the cylinder is used for positioning in the extended rod position you should consider that a possible counter-force will cause an axial deflection of approx. 1 mm. This feature is due to the cylinder's design because after the nominal power stroke the clamping force drops down to the level of the piston force (see force-stroke diagram left side).
- Valves are not usable to avoid piston movement. If the piston should be positioned within the range of the forward stroke, both chambers of the cylinder have to be vented. If the cylinder should stay at a retracted position the piston rod chamber should be under pressure and the piston chamber should be vented.
- For further facts and additional applications features see operating instruction MAPnkz-2.



# PNEUMATIC POWER CYLINDERS

## Functions

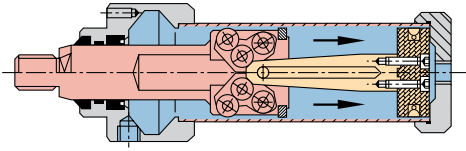

Basic position

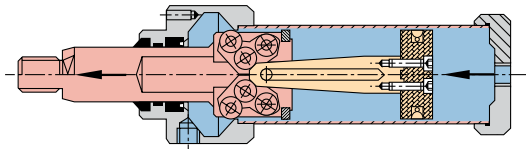

Forward stroke

Piston force is identical to the force of a common pneumatic cylinder with adequate piston diameter

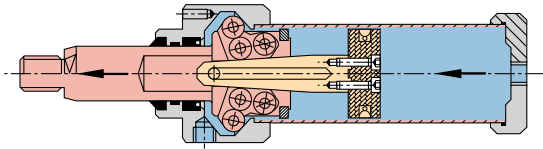

Power stroke

Beginning of mechanical force amplification. Mechanical advantage max. 10:1

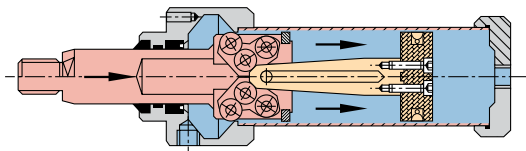

Return stroke

The return stroke can be initiated in any position of piston. The force during return stroke is approx. half of piston force.

## Forces

Force within forward stroke

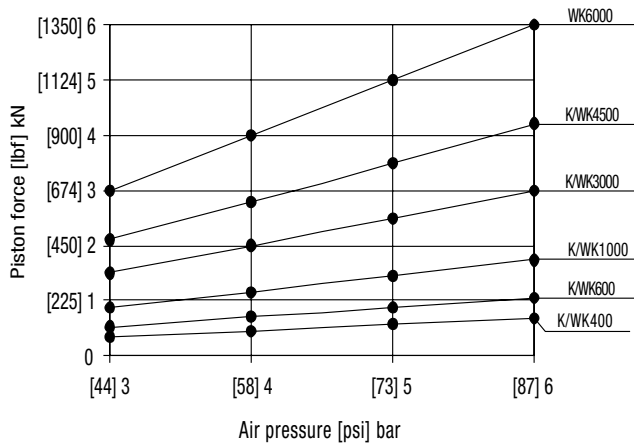

Clamping force within power stroke

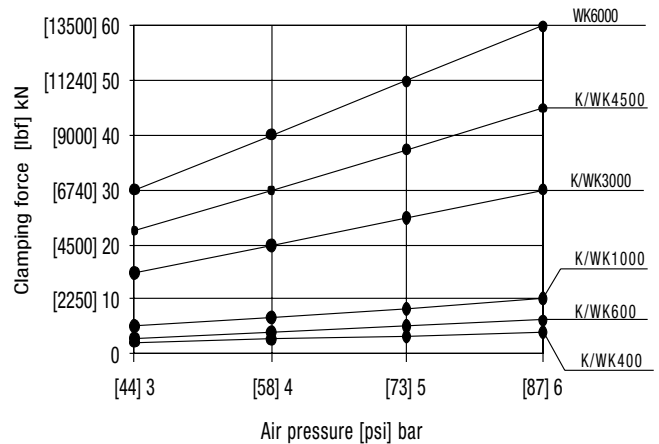

Return stroke force: half of piston force

# TYPE K SERIES

## Pneumatic Power Cylinders | Product Overview | Technical Information



- Piston rod with male thread

### Note:

Operating pressure max. 6 bar [87psi], min 3 bar [44psi]. Use only clean, water- and oilfree compressed air. Piston rod is not secured against twisting and should not be loaded transversal.

See page MC-PPC-2 for more information.

Model	Piston force within forward stroke at 6 bar kN [lbf]	Forward stroke mm [in]	Clamping force within power stroke at 6 bar kN [lbf]	Power stroke mm [in]	Piston dia. mm [in]	Air consumption per double stroke at 6 bar dm <sup>3</sup> [ft <sup>3</sup> ]	Stroke frequency depending on total stroke [min <sup>-1</sup> ]	Temperature range °C [°F]	Weight Kg [lbs]
K400-15-6-1	0,68 [153]	15 [0.59]	4 [900lbf]	6 [0.24]	40 [1.75]	0,71 [0.025]	5 to 30	- 5 to +75 [23 to 167]	1,20 [2.6]
K400-30-6-1		30 [1.18]				0,89 [0.031]			1,25 [2.8]
K400-50-6-1		50 [1.97]				1,14 [0.040]			1,30 [2.9]
K400-70-6-1		70 [2.76]				1,38 [0.049]			1,35 [3.0]
K400-120-6-1		120 [4.72]				1,98 [0.070]			1,50 [3.3]
K400-200-6-1	200 [7.87]	2,94 [0.104]	1,70 [3.7]						
K600-15-6-1	1,06 [238]	15 [0.59]	6 [1350lbf]	6 [0.24]	50 [1.97]	1,34 [0.047]	5 to 30	- 5 to +75 [23 to 167]	2,05 [4.5]
K600-30-6-1		30 [1.18]				1,65 [0.058]			2,15 [4.7]
K600-50-6-1		50 [1.97]				2,06 [0.073]			2,30 [5.1]
K600-70-6-1		70 [2.76]				2,47 [0.087]			2,40 [5.3]
K600-120-6-1		120 [4.72]				3,50 [0.124]			2,70 [6.0]
K600-200-6-1	200 [7.87]	5,15 [0.182]	3,20 [7.1]						
K1000-15-7-1	1,75 [393]	15 [0.59]	10 [2250lbf]	7* [0.27]	63 [2.48]	2,20 [0.078]	5 to 30	- 5 to +75 [23 to 167]	3,60 [7.9]
K1000-30-7-1		30 [1.18]				2,66 [0.094]			3,80 [8.4]
K1000-50-7-1		50 [1.97]				3,26 [0.115]			4,10 [9.0]
K1000-70-7-1		70 [2.76]				3,85 [0.136]			4,40 [9.7]
K1000-120-7-1		120 [4.72]				5,35 [0.189]			5,20 [11.5]
K1000-200-7-1	200 [7.87]	7,74 [0.273]	6,40 [14.1]						
K3000-15-6-1	3 [674]	15 [0.59]	30 [6700lbf]	6* [0.24]	85 [3.35]	4,48 [0.158]	5 to 25	- 5 to +75 [23 to 167]	11,80 [26.0]
K3000-30-6-1		30 [1.18]				5,20 [0.184]			12,50 [27.6]
K3000-50-6-1		50 [1.97]				6,17 [0.218]			13,40 [29.5]
K3000-70-6-1		70 [2.76]				7,13 [0.252]			14,30 [31.5]
K3000-120-6-1		120 [4.72]				9,54 [0.337]			16,60 [36.6]
K3000-200-6-1	200 [7.87]	13,40 [0.473]	20,20 [44.5]						
K4500-15-6-1	4,2 [944]	15 [0.59]	45 [10120lbf]	6* [0.24]	100 [3.94]	6,18 [0.218]	5 to 25	- 5 to +75 [23 to 167]	13,30 [29.3]
K4500-30-6-1		30 [1.18]				7,17 [0.253]			14,00 [30.9]
K4500-50-6-1		50 [1.97]				8,50 [0.300]			15,00 [33.1]
K4500-70-6-1		70 [2.76]				9,83 [0.347]			15,80 [34.8]
K4500-120-6-1		120 [4.72]				13,20 [0.466]			18,10 [39.9]
K4500-200-6-1	200 [7.87]	18,50 [0.653]	21,70 [47.8]						

\* Power strokes up to 12 mm and other forward strokes upon request

### Type K in standard version

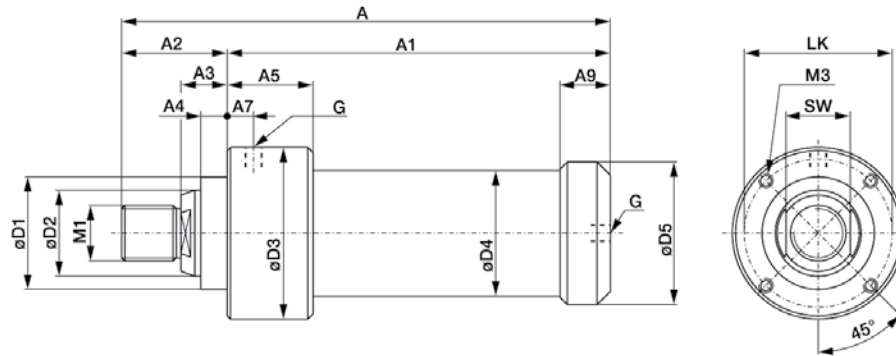

Model	Dimensions for standard version of type K Differences of dimensions for cylinder with magnet piston rings see chart on page MC-PPC-10																	
	A	A <sub>1</sub>	A <sub>2</sub>	A <sub>3</sub>	A <sub>4</sub>	A <sub>5</sub>	A <sub>7</sub>	A <sub>9</sub>	Ø D <sub>1</sub>	Ø D <sub>2</sub>	Ø D <sub>3</sub>	Ø D <sub>4</sub>	Ø D <sub>5</sub>	M <sub>1</sub>	M <sub>3</sub>	LK	SW	G
K400-15-6-1	186 [7.32]	145 [5.71]																
K400-30-6-1	201 [7.91]	160 [6.30]																
K400-50-6-1	221 [8.70]	180 [7.09]	41 [1.6]	21 [0.8]	12 [0.5]	39 [1.5]	10 [0.4]	23,5 [0.9]	40 <sub>h8</sub> [1.6]	25 <sub>h7</sub> [1.0]	63 [2.5]	44 [1.7]	49 [1.9]	M16 x 1,5 [0.06]	M5, 10mm deep [0.1]	54 [2.1]	21 [0.8]	G1/8
K400-70-6-1	241 [9.49]	200 [7.87]																
K400-120-6-1	291 [11.46]	250 [9.84]																
K400-200-6-1	371 [14.61]	330 [12.99]																
K600-15-6-1	201 [7.91]	160 [6.30]																
K600-30-6-1	216 [8.50]	175 [6.89]																
K600-50-6-1	236 [9.29]	195 [7.68]	41 [1.6]	21 [0.8]	12 [0.5]	39 [1.5]	10 [0.4]	23,5 [0.9]	40 <sub>h8</sub> [1.6]	25 <sub>h7</sub> [1.0]	73 [2.9]	54 [2.1]	59 [2.3]	M16 x 1,5 [0.06]	M6, 10mm deep [0.1]	64 [2.5]	21 [0.1]	G1/8
K600-70-6-1	256 [10.08]	215 [8.46]																
K600-120-6-1	306 [12.05]	265 [10.43]																
K600-200-6-1	386 [15.20]	345 [13.58]																
K1000-15-7-1	243 [9.57]	187 [7.36]																
K1000-30-7-1	258 [10.16]	202 [7.95]																
K1000-50-7-1	278 [10.94]	222 [8.74]	56 [2.2]	25 [1.0]	15 [0.6]	52 [2.0]	10 [0.4]	29 [1.1]	63 <sub>h8</sub> [2.5]	40 <sub>h7</sub> [1.6]	100 [3.9]	68 [2.7]	74,5 [2.9]	M24 x 3,0 [0.98]	M8, 12mm deep [1]	85 [3.3]	32 [1.3]	G1/8
K1000-70-7-1	298 [11.73]	242 [9.53]																
K1000-120-7-1	348 [13.70]	292 [11.50]																
K1000-200-7-1	428 [16.85]	372 [14.65]																

# TYPE K SERIES

## Pneumatic Power Cylinders | Technical Information

### Type K in standard version

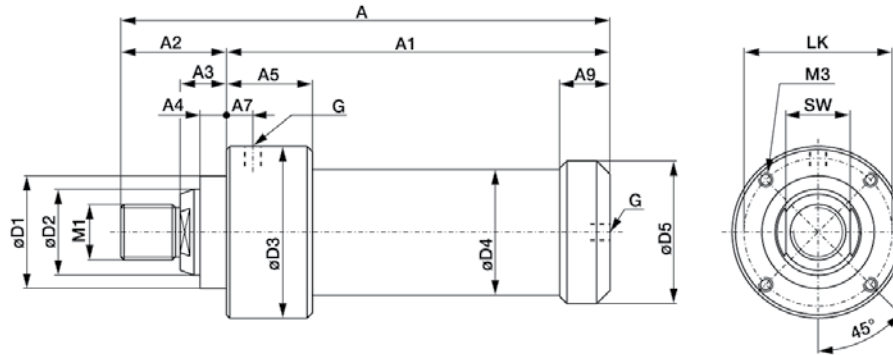

Model	Dimensions for standard version of type K Differences of dimensions for cylinder with magnet piston rings see chart on page MC-PPC-10																		
	A	A <sub>1</sub>	A <sub>2</sub>	A <sub>3</sub>	A <sub>4</sub>	A <sub>5</sub>	A <sub>7</sub>	A <sub>9</sub>	øD <sub>1</sub>	øD <sub>2</sub>	øD <sub>3</sub>	øD <sub>4</sub>	øD <sub>5</sub>	M <sub>1</sub>	M <sub>3</sub>	LK	SW	G	
K3000-15-6-1	315 [12.40]	235 [9.25]																	
K3000-30-6-1	330 [12.99]	250 [9.84]																	
K3000-50-6-1	350 [13.78]	270 [10.63]	50 [2.0]	35 [1.4]	20 [0.8]	70 [2.8]	20 [0.8]	45 [1.8]	85 <sub>h8</sub> [3.3]	65 <sub>h7</sub> [2.6]	130 [5.1]	95 [3.7]	108 [4.3]	M42 [1.65]	M10, 16mm deep [1.7]	112 [4.4]	55 [2.2]	G1/4	
K3000-70-6-1	370 [14.57]	290 [11.42]																	
K3000-120-6-1	420 [16.54]	340 [13.39]																	
K3000-200-6-1	500 [19.69]	420 [16.54]																	
K4500-15-6-1	315 [12.40]	235 [9.25]																	
K4500-30-6-1	330 [12.99]	250 [9.84]																	
K4500-50-6-1	350 [13.78]	270 [10.63]	80 [3.1]	35 [1.4]	20 [0.8]	70 [2.8]	20 [0.8]	45 [1.8]	85 <sub>h8</sub> [3.3]	65 <sub>h7</sub> [2.6]	145 [5.7]	110 [4.3]	123 [4.8]	M42 [1.65]	[1.7] M10, 16mm deep	127 [5.0]	55 [2.2]	G1/4	
K4500-70-6-1	370 [14.57]	290 [11.42]																	
K4500-120-6-1	420 [16.54]	340 [13.39]																	
K4500-200-6-1	500 [19.69]	420 [16.54]																	

# TYPE WK SERIES

## Pneumatic Power Cylinders | Product Overview | Technical Information



- Piston rod with ISO fit

Note:

Operating pressure max. [87psi]6 bar, min [44psi] 3 bar. Use only clean, water- and oilfree compressed air. Piston rod is not secured against twisting and should not be loaded transversal.

See page MC-PPC-2 for more information.

Model	Piston force within forward stroke at 6 bar kN [lbf]	Forward stroke mm [in]	Clamping force within power stroke at 6 bar kN [lbf]	Power stroke mm [in]	Piston dia. mm [in]	Air consumption per double stroke at 6 bar dm <sup>3</sup> [ft <sup>3</sup> ]	Stroke frequency depending on total stroke [min <sup>-1</sup> ]	Temperature range °C [°F]	Weight [lbs] kg
WK400-15-6-1	0,68 [153]	15 [0.59]	4 [900lbf]	6 [0.24]	40 [1.75]	0,71 [0.025]	5 to 30	- 5 to +75 [23 to 167]	1,20 [2.6]
WK400-30-6-1		30 [1.18]				0,89 [0.031]			1,25 [2.8]
WK400-50-6-1		50 [1.97]				1,14 [0.040]			1,30 [2.9]
WK400-70-6-1		70 [2.76]				1,38 [0.049]			1,35 [3.0]
WK400-120-6-1		120 [4.72]				1,98 [0.070]			1,50 [3.3]
WK400-200-6-1		200 [7.87]				2,94 [0.104]			1,70 [3.7]
WK600-15-6-1	1,06 [238]	15 [0.59]	6 [1350lbf]	6 [0.24]	50 [1.97]	1,34 [0.047]	5 to 30	- 5 to +75 [23 to 167]	2,05 [4.5]
WK600-30-6-1		30 [1.18]				1,65 [0.058]			2,15 [4.7]
WK600-50-6-1		50 [1.97]				2,06 [0.073]			2,30 [5.1]
WK600-70-6-1		70 [2.76]				2,47 [0.087]			2,40 [5.3]
WK600-120-6-1		120 [4.72]				3,50 [0.124]			2,70 [6.0]
WK600-200-6-1		200 [7.87]				5,15 [0.182]			3,20 [7.1]
WK1000-15-7-1	1,75 [393]	15 [0.59]	10 [2250lbf]	7* [0.27]	63 [2.48]	2,20 [0.078]	5 to 30	- 5 to +75 [23 to 167]	3,60 [7.9]
WK1000-30-7-1		30 [1.18]				2,66 [0.094]			3,80 [8.4]
WK1000-50-7-1		50 [1.97]				3,26 [0.115]			4,10 [9.0]
WK1000-70-7-1		70 [2.76]				3,85 [0.136]			4,40 [9.7]
WK1000-120-7-1		120 [4.72]				5,35 [0.189]			5,20 [11.5]
WK1000-200-7-1		200 [7.87]				7,74 [0.273]			6,40 [14.1]
WK3000-15-6-1	3 [674]	15 [0.59]	30 [6700lbf]	6* [0.24]	85 [3.35]	4,48 [0.158]	5 to 25	- 5 to +75 [23 to 167]	11,80 [26.0]
WK3000-30-6-1		30 [1.18]				5,20 [0.184]			12,50 [27.6]
WK3000-50-6-1		50 [1.97]				6,17 [0.218]			13,40 [29.5]
WK3000-70-6-1		70 [2.76]				7,13 [0.252]			14,30 [31.5]
WK3000-120-6-1		120 [4.72]				9,54 [0.337]			16,60 [36.6]
WK3000-200-6-1		200 [7.87]				13,40 [0.473]			20,20 [44.5]
WK4500-15-6-1	4,2 [944]	15 [0.59]	45 [10120lbf]	6* [0.24]	100 [3.94]	6,18 [0.218]	5 to 25	- 5 to +75 [23 to 167]	13,30 [29.3]
WK4500-30-6-1		30 [1.18]				7,17 [0.253]			14,00 [30.9]
WK4500-50-6-1		50 [1.97]				8,50 [0.300]			15,00 [33.1]
WK4500-70-6-1		70 [2.76]				9,83 [0.347]			15,80 [34.8]
WK4500-120-6-1		120 [4.72]				13,20 [0.466]			18,10 [39.9]
WK4500-200-6-1		200 [7.87]				18,50 [0.653]			21,70 [47.8]
WK6000-30-6	6,0 [1350]	[1.18] 30	60,0 [13490lbf]	6* [0.24]	125,0 [4.92]	[0.367] 10,40	5 to 25	- 5 to +75 [23 to 167]	24,00 [52.9]
WK6000-50-6		[1.97] 50				[0.454] 12,85			24,50 [54.0]
WK6000-70-6		[2.76] 70				[0.536] 15,17			25,00 [55.1]
WK6000-120-6		[4.72] 120				[0.747] 21,15			26,50 [58.4]

\* Power strokes up to 12 mm and other forward strokes upon request

# TYPE WK SERIES

## Pneumatic Power Cylinders | Technical Information

### Type WK in standard version

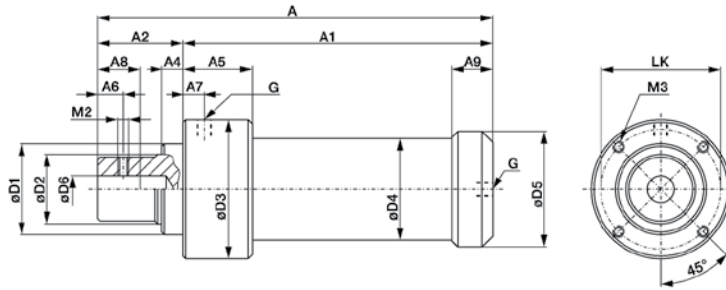

Model	Dimensions for standard version of type WK																		
	Differences of dimensions for cylinder with magnet piston rings see chart on page MC-PPC-10																		
	A	A <sub>1</sub>	A <sub>2</sub>	A <sub>3</sub>	A <sub>4</sub>	A <sub>5</sub>	A <sub>7</sub>	A <sub>8</sub> **	A <sub>9</sub>	Ø D <sub>1</sub>	Ø D <sub>2</sub>	Ø D <sub>3</sub>	Ø D <sub>4</sub>	Ø D <sub>5</sub>	Ø D <sub>6</sub>	M <sub>2</sub>	M <sub>3</sub>	LK	G
WK400-15-6-1	186 [7.32]	145 [5.71]																	
WK400-30-6-1	201 [7.91]	160 [6.30]																	
WK400-50-6-1	221 [8.70]	180 [7.09]	41 [1.61]	21 [0.83]	12 [0.47]	39 [1.54]	10 [0.39]	25 [0.98]	23,5 [0.93]	40 <sub>h7</sub> [1.57]	25 <sub>h7</sub> [0.98]	63 [2.48]	44 [1.73]	49 [1.93]	10 <sup>H7</sup>	M6	M5, 10mm deep [0.06]	54 [2.13]	G1/8
WK400-70-6-1	241 [9.49]	200 [7.87]																	
WK400-120-6-1	291 [11.46]	250 [9.84]																	
WK400-200-6-1	371 [14.61]	330 [12.99]																	
WK600-15-6-1	201 [7.91]	160 [6.30]																	
WK600-30-6-1	216 [8.50]	175 [6.89]																	
WK600-50-6-1	236 [9.29]	195 [7.68]	41 [1.61]	21 [0.83]	12 [0.47]	39 [1.54]	10 [0.39]	25 [0.98]	23,5 [0.93]	40 <sub>h7</sub> [1.57]	25 <sub>h7</sub> [0.98]	73 [2.87]	54 [2.13]	[2.32] 59	10 <sup>H7</sup>	M6	M6, 10mm deep [0.06]	64 [2.52]	G1/8
WK600-70-6-1	256 [10.08]	215 [8.46]																	
WK600-120-6-1	306 [12.05]	265 [10.43]																	
WK600-200-6-1	386 [15.20]	345 [13.58]																	
WK1000-15-7-1	243 [9.57]	187 [7.36]																	
WK1000-30-7-1	258 [10.16]	202 [7.95]																	
WK1000-50-7-1	278 [10.94]	222 [8.74]	56 [2.20]	25 [0.98]	15 [0.59]	52 [2.05]	10 [0.39]	40 [1.57]	29 [1.14]	63 <sub>h8</sub> [2.48]	40 <sub>h7</sub> [1.57]	99,5 [3.92]	68 [2.68]	74,5 [2.93]	20 <sup>H7</sup>	M8	M8, 12mm deep [0.98]	85 [3.35]	G1/8
WK1000-70-7-1	298 [11.73]	242 [9.53]																	
WK1000-120-7-1	348 [13.70]	292 [11.50]																	
WK1000-200-7-1	428 [16.85]	372 [14.65]																	

Continued on next page

# TYPE WK SERIES

## Pneumatic Power Cylinders | Technical Information

### Type WK in standard version

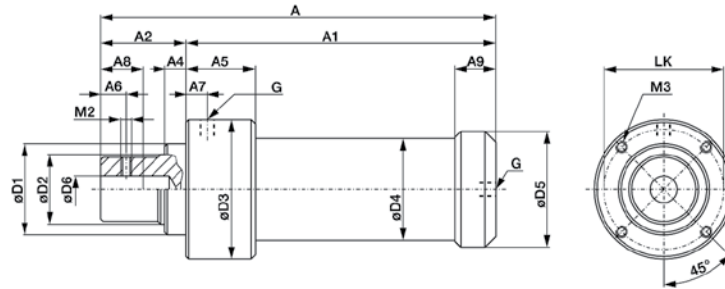

Model	Dimensions for standard version of type WK Differences of dimensions for cylinder with magnet piston rings see chart on page MC-PPC-10																			
	A	A <sub>1</sub>	A <sub>2</sub>	A <sub>3</sub>	A <sub>4</sub>	A <sub>5</sub>	A <sub>7</sub>	A <sub>8</sub> **	A <sub>9</sub>	Ø D <sub>1</sub>	Ø D <sub>2</sub>	Ø D <sub>3</sub>	Ø D <sub>4</sub>	Ø D <sub>5</sub>	Ø D <sub>6</sub>	M <sub>2</sub>	M <sub>3</sub>	LK	G	
WK3000-15-6-1	315 [12.40]	235 [9.25]																		
WK3000-30-6-1	330 [12.99]	250 [9.84]																		
WK3000-50-6-1	350 [13.78]	270 [10.63]	80 [3.15]	35 [1.38]	20 [0.79]	70 [2.76]	20 [0.79]	40 [1.57]	45 [1.77]	85 <sub>h8</sub> [3.35]	65 <sub>h7</sub> [2.56]	130 [5.12]	95 [3.74]	108 [4.25]	25 <sup>H7</sup>	M10	M10, 16mm deep [16]	112 [4.41]	G1/4	
WK3000-70-6-1	370 [14.57]	290 [11.42]																		
WK3000-120-6-1	420 [16.54]	340 [13.39]																		
WK3000-200-6-1	500 [19.69]	420 [16.54]																		
WK4500-15-6-1	315 [12.40]	235 [9.25]																		
WK4500-30-6-1	330 [12.99]	250 [9.84]																		
WK4500-50-6-1	350 [13.78]	270 [10.63]	80 [3.15]	35 [1.38]	20 [0.79]	70 [2.76]	20 [0.79]	40 [1.57]	45 [1.77]	85 <sub>h8</sub> [3.35]	65 <sub>h7</sub> [2.56]	145 [5.71]	110 [4.33]	123 [4.84]	25 <sup>H7</sup>	M10	M10, 16mm deep [1.65]	127 [5.00]	G1/4	
WK4500-70-6-1	370 [14.57]	290 [11.42]																		
WK4500-120-6-1	420 [16.54]	340 [13.39]																		
WK4500-200-6-1	500 [19.69]	420 [16.54]																		
WK6000-30-6	365 [14.37]	285 [11.22]																		
WK6000-50-6	385 [15.16]	305 [12.01]	80 [3.15]	20 [0.79]	48 [1.89]	24 [0.94]	22 [0.87]	40 [1.57]	53 [2.09]	85 <sub>h8</sub> [3.35]	65 <sub>h7</sub> [2.56]	178 [7.01]	135 [5.31]	148 [5.83]	25 <sup>H7</sup>	M10	M10, 16mm deep [1.65]	150 [5.91]	G1/2	
WK6000-70-6	405 [15.94]	325 [12.80]																		
WK6000-120-6	455 [17.91]	375 [14.76]																		

\*\* Usable depth of bore with ISO fit D6

# TYPE WR SERIES

## Pneumatic Power Cylinders | Product Overview

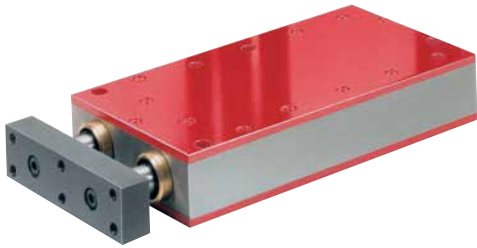

- Piston rods prevent twisting

**Note:**

Use only clean, water- and oilfree compressed air. Force must be transmitted via the centre of the pressure plate. One-sided loading of the pressure plate should be avoided. For punching applications contact our technical support! See page MC-PPC-2 for more information.

### Type WR

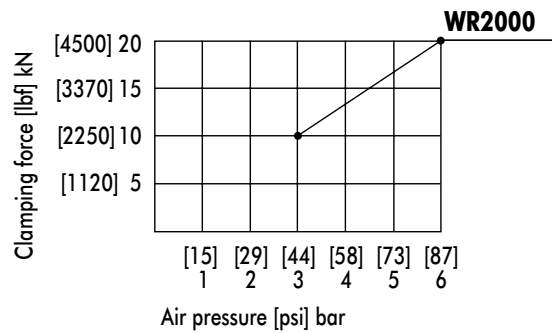
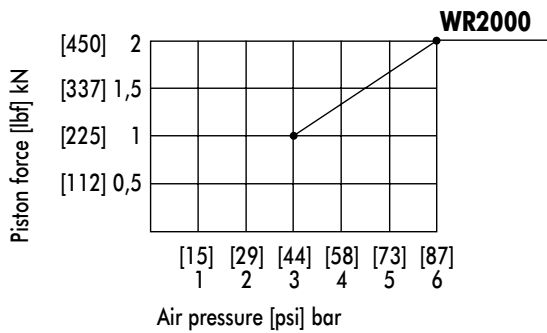
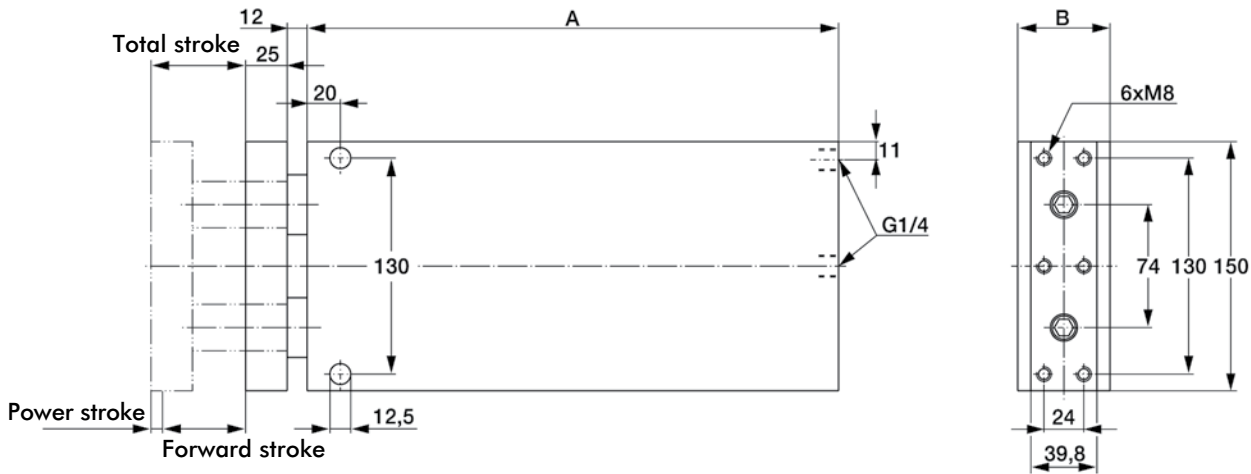

Return stroke force: half of piston force

Air pressure: max. [87psi] 6 bar; min. [44psi] 3 bar

Model	Piston force within forward stroke at 6 bar kN [lbf]	Forward stroke mm [in]	Clamping force within power stroke at 6 bar [lbf] kN	Power stroke mm [in]	Piston dia. mm [in]	Air consumption per double stroke at 6 bar dm <sup>3</sup> [ft <sup>3</sup> ]	Stroke frequency depending on total stroke [min <sup>-1</sup> ]	Temperature range °C [°F]	Weight kg [lbs]	A	B
WR 2000-15-7	2 [450]	15 [0.59]	20 [4500]	7 [0.27]	70 [2.76]	2,44 [0.086]	5 - 25	-5 up to +75 [23 to up167]	12,5 [27.6]	285	51,6
WR 2000-30-7		30 [1.18]				2,95 [0.104]			14,0 [30.9]	300	51,6
WR 2000-50-7		50 [1.97]				3,62 [0.128]			15,5 [34.1]	320	55,6
WR 2000-70-7		70 [2.76]				4,27 [0.151]			17,2 [37.9]	340	55,6
WR 2000-120-7		120 [4.72]				5,94 [0.210]			21,0 [46.3]	390	59,6



### Pneumatic Power Cylinders Type K and WK with end position control by magnetic field sensors.

- **For the sizes**  
K and WK 400.... , K and WK 600... ,  
K and WK 1000.... K and WK 3000...,  
K and WK 4500...
- **Change of Model**  
Indicate „-A“ at the end of Model instead of „-1“  
for standard version!  
Example:  
K400 – 15 – 6 – 1 change to K400 – 15 – 6 – A  
WK 3000 – 50 – 6 – 1 change to WK 3000 – 50 – 6 – A
- **Change in construction**  
Only the dimensions Ø D4, Ø D5, A/A 1 and A9 are  
different to the standard version.



- **Standard equipment (as shown above)**  
Pneumatic Power Cylinders with „-A“ at the end of  
Model are completely furnished with a magnetic  
piston ring and with two mounted sensor sets  
(Model SMB-102157, consisting of magnetic field  
sensor with 3m cable, clamp and strap)

#### Type K

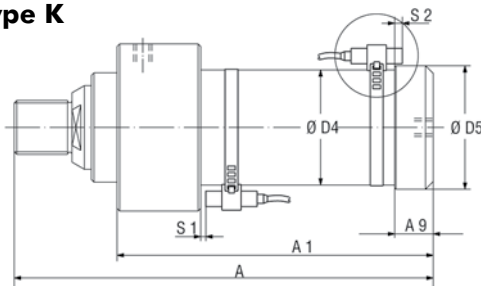

Switching points of sensors			**Differences of dimensions compared with standard version				
For sizes	S1*	S2*	Ø D4	Ø D5	A/A 1	A9	Rs
K 400-...-A	5	12	-	-	+15	-	44
K 1000-...-A	10	18	-	-	+15	-	56
K 3000-...-A	5	14	90	97	-	30	67
K 45000-...-A	5	12	106	113	-	28,5	75

\* Approx. data, because of magnet field variations. S1 refers to the max. power stroke and enlarges up to 60 mm, when smaller power strokes are used.

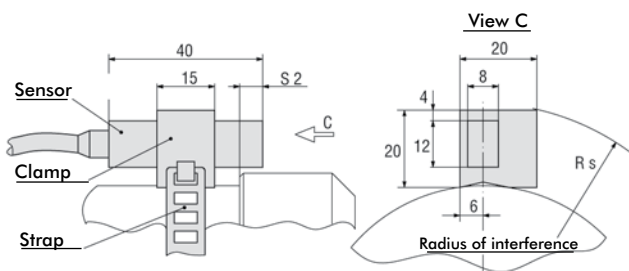

Circuit diagram and technical data of sensor set Model **SMB-102157**, consisting of magnetic field sensor with 3 m cable, clamp and strap (2 sets per cylinder are standard equipment).

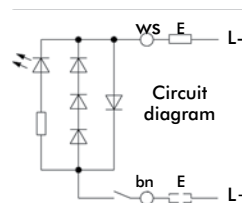

Switching voltage	10...250 VAC/DC
Switching current	0,5 A
Switching power	20 W/30 VA
Function	normally open contact
Protection class	IP 67 (DIN 40050)
Indicator	LED

#### Type WK

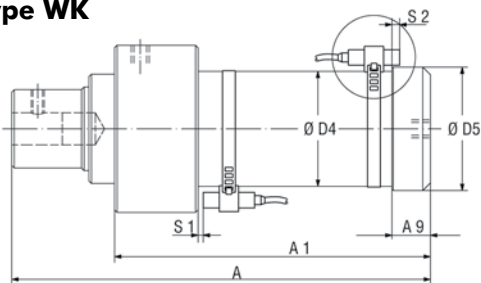

Switching points of sensors			**Differences of dimensions compared with standard version				
For sizes	S1*	S2*	Ø D4	Ø D5	A/A 1	A9	Rs
WK 400-...-A	5	12	-	-	+15	-	44
WK 1000-...-A	10	18	-	-	+15	-	56
WK 3000-...-A	5	14	90	97	-	30	67
WK 45000-...-A	5	12	106	113	-	28,5	75

\* Approx. data, because of magnet field variations. S1 refers to the max. power stroke and enlarges up to 60 mm, when smaller power strokes are used.

# -K OPTION

## Magnetic Field Sensing | Technical Specifications



### Sensor cage for T-slot proximity sensor

- **For the sizes**  
K and WK 400.... , K and WK 600... , K and WK 1000.... ,  
K and WK 3000..., K and WK 4500...
- **Change of Model**  
Indicate "-K" at the end of Model instead of "-A" for  
standard version.  
Example:  
K400 – 15 – 6 – A change to K400 – 15 – 6 – K  
WK 3000 – 50 – 6 – A change to WK 3000 - 50 – 6 – K
- **Benefits:**  
Small radii of interference.  
Customer specific T-slot sensors are usable.
- **Standard equipment:**  
Pneumatic power cylinder with "-K" at the end of Model  
number are supplied with mounted sensor cages but  
without T-slot sensors.

# PNEUMATIC POWER CYLINDERS

## Application Examples



Radius clinching unit for profiled aluminium

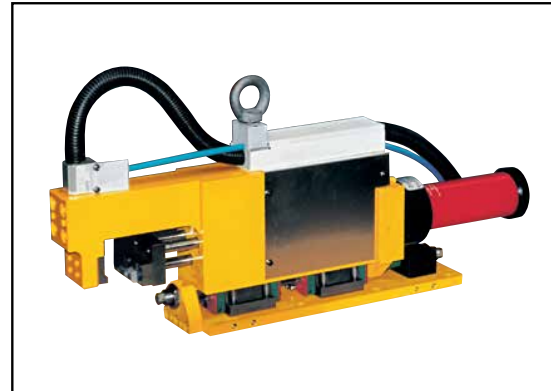

Special punching unit for 2 holes Ø 3,4 in steel 0,9 mm

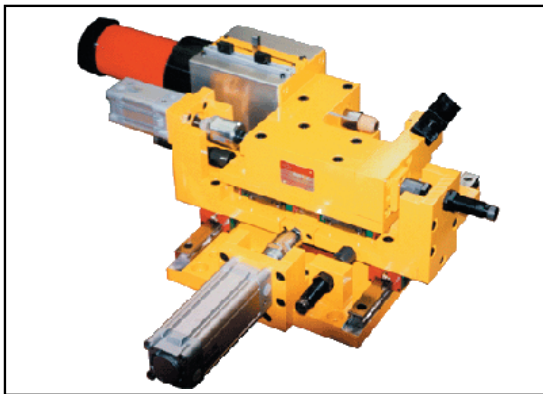

Special device for 2 holes Ø 12 in steel 1,2 mm

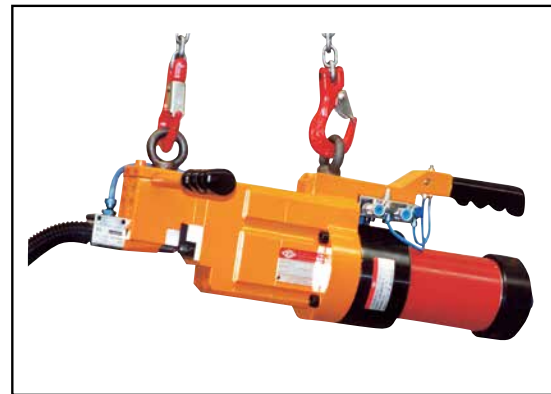

Mobile punching unit for holes Ø 6,2 in crossbeams



Device for holes Ø 8 in sheet metal



Stamping units placed in line



Stamping units placed in line

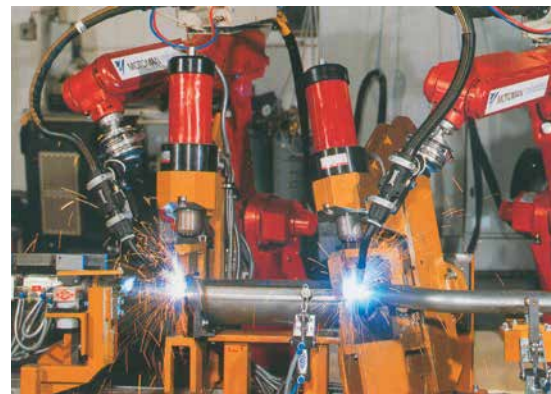

Welding fixture for exhaust components

# TECHNICAL APPENDIX

## Manual Clamping Technology

### Selecting The Proper DESTACO Clamp

The information contained in this catalog is designed to help you select the right clamp to accomplish your job. DESTACO distributor personnel, as well as DESTACO's Technical Service department, are qualified and willing to offer assistance in special or unusual applications. For most ordinary applications, however, consideration of the following points will lead to the proper clamp selection

- Size and shape of the parts to be held.
- Uniformity of part size (Should you consider a spring-loaded spindle to compensate for uneven parts?)
- Holding capacity required
- Strength and dexterity of the operator
- Operator's position (Should you use horizontal or vertical handle models?)
- Frequency of operation (Should you plan for a temporary or permanent fixture?)
- Time cycle of operation (Should you consider a turntable or conveyor set-up if curing time is required?)
- Cycling time and sequence (Should you consider air-operated models that can be operated faster and in sequence?)
- Environment (Should a stainless steel model be considered?)

### Processing Applications

Remember, the same toggle action force multiplying principle can be applied to other tasks besides holding. Certain DESTACO models can be used to position parts, power fixtures or perform mechanical functions such as piercing sheet metal, staking rivets or locating.

### OEM Applications

DESTACO clamps provide ready-made, compact devices for moving or holding components. A little imagination will often show the product designer a way to obtain motion or locking force with no tooling costs and often at less cost than custom designed components. Thousands of DESTACO clamps will be found installed as original equipment for cleanout door latches, wheel locks, positioning devices, etc.

### Safety

Our concern is not only the constant high quality of our products, but also their fail-safe and foolproof handling. The knowledge gathered since 1936 guarantees a developed, safe and high-quality clamping unit.

A certain clamping force will be necessary to safely hold a part. This force is determined by taking the following into account:

- (A) the part material: such as, steel, wood, plastic or glass, etc.
- (B) the surface finish of the part: such as, polished, hard or soft, etc.
- (C) the machining or assembly operation: such as, milling, welding, drilling, bonding, joining or sealing a mold, etc.

In order to ensure clamp strength is not compromised, use all the mounting holes provided.

Red handle grips are provided on each model. Users should only locate their hand in this area when operating the clamp, thus reducing the possibility of injury.

### Safety Handle

This ergonomic handle provides greater operator comfort.



### Safety Feature

This safety link prevents accidental injury to an operator when opening the clamp.

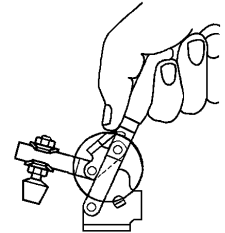

**Clamp Series** 201, 202, 207, 210,247,267

### Safety Distance

Exclusive handle design gives more hand clearance between bar and handle when clamp is in fully open position.

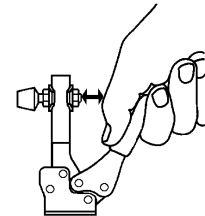

**Clamp Series** 213, 217, 227, 237, 245

# TECHNICAL APPENDIX

## Manual Clamping Technology

### DESTACO Toggle-Lock Plus™ Clamps

We have taken several of our most popular toggle clamps and have added a locking release lever for improved safety. The locking release lever helps ensure that the over-center locking condition is maintained. In order to unlock each clamp, the locking lever must first be released. The additional locking feature expands the range of applications where DESTACO® clamps can be used. If a clamp application warrants concerns over accidental or unintentional opening, then a DESTACO® Toggle-Lock Plus™ clamp is right for the job.

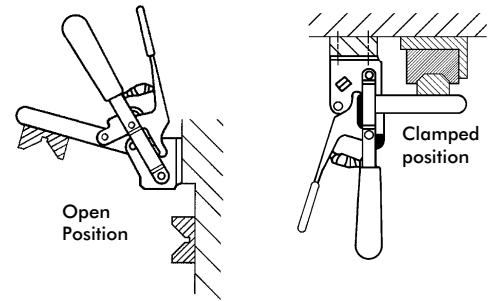

### The most important models at a glance:

#### Vertical hold-down clamp

- Handle is vertical in clamped position
- Holding capacities up to 22,25kN [5000lbf.]
- Opening angle between 65° and 215°

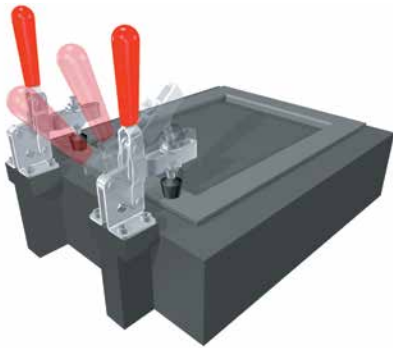

#### Straight line action clamp

- Forward movement of the handle pushes the plunger into the forward position
- Can be used as a push clamp and pull clamp, locking in two positions
- Holding capacities of 445N-71,2kN [100-6,000lbf.]

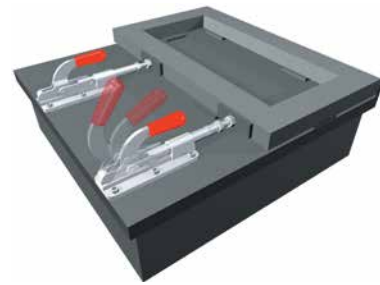

#### Horizontal hold-down clamp

- Very low profile
- Handle is horizontal in the clamped position
- Holding capacities up to 7,5kN [1,680lbf.]
- Opening angle between 90° and 105°

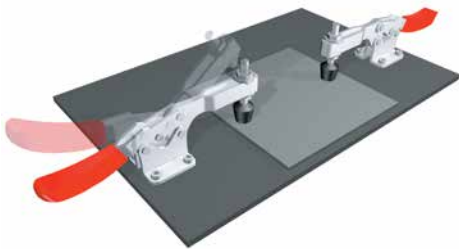

#### Latch clamp

- Convenient one-hand operation due to the patented thumb control lever
- Compact models
- Holding capacities up to 33,4kN [7,500lbf.]



#### Plier clamp

- Flexible clamping and fixturing
- Also equipped with quick release lever
- Holding capacities 450N-5340N [100-1200lbf.]



# TECHNICAL APPENDIX

## Manual Clamping Technology

### How Toggle Action Works

Toggle action clamps operate through a linkage system of levers and pivots. The fixed-length levers, connected by pivot pins, supply the action and clamping force. Toggle action has an over-center lock point which is a fixed stop and linkage. Once in the over-center position, the clamp cannot move or unlock unless the linkage is moved. All types of toggle clamps have this same action, just oriented differently.

### Toggle Action Force Factors

The maximum clamping or exerting force developed in any toggle action clamp is attained when the three pivot points of the mechanism are in a straight line. While this is theoretically true, it makes no allowance for vibration and intermittent load conditions found in industrial applications. Such conditions would soon unlock an improperly designed clamp. The proper amount of over-center travel to produce maximum holding force and yet ensure positive locking is a carefully calculated and controlled dimension developed by years of experimentation and experience.

Throughout this catalog each clamp is rated with its "holding capacity." This is the maximum load or force the clamp will sustain in the closed and locked position without permanent deflection. Exerting forces applied as the clamp closes are less than the holding capacity, and are dependent on variables such as the position of the operator's hand on the handle; amount of force applied; and position of the spindle on the bar.

### What about the forces?

In the case of clamping products, a clear distinction must be made between exerting forces and holding capacities. Here are the essential features:

### Exerting or Clamping Force

The "exerting force" of our air toggle clamps is well defined and can be found on page 7. Manually operated clamps present a series of variables to determine actual exerting force.

These variables are:

- the force exerted on the handle by the operator;
- the point on the handle where this force is applied;
- the mechanical advantage in the linkage; and
- the point on the work holding bar where the force will be measured. As a general rule, the mechanical advantage available throughout the line ranges 2:1 to 10:1

### Toggle Action Principle

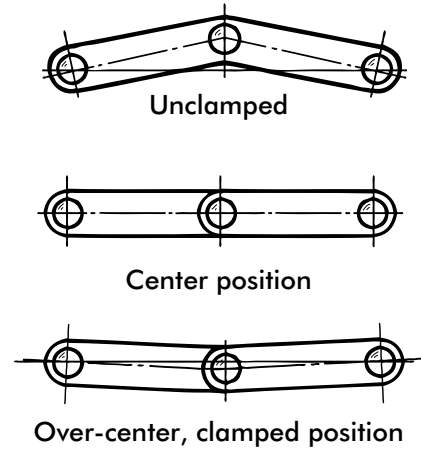

### Toggle Action Clamps Compared with Cam Action Clamps

Cam action uses frictional force to effect a locking condition between the cam surface on the bar and the follower on the handle. Toggle action clamps have many advantages over cam action clamps, mainly because cam action clamps allow some movement while clamping. Toggle action clamps thus provide a more consistent clamping point, can be manufactured from inexpensive materials, and are available in stainless steel for outdoor or corrosive applications. If the material being clamped has a variable thickness, however, a cam action clamp has the ability to better accommodate this application.

### Holding Capacity

The "holding capacity" of DESTACO toggle clamps has been determined by actual tests. It is defined as the maximum amount of force which may be applied to the work holding bar, in the closed position, without creating permanent deformation of the clamp components. This maximum force is measured at a point closest to the base and diminishes as the spindle approaches the end of the bar. The ratings for holding capacity are maximum and should not be exceeded.

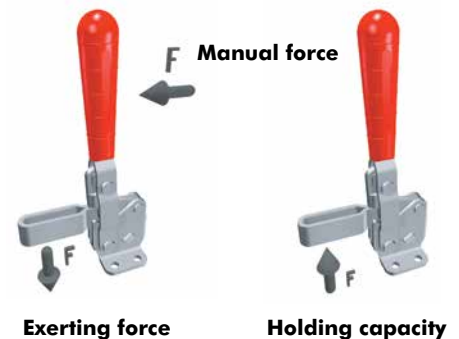

### Calculating Exerting or Clamping Force

The table below depicts holding capacity (HC) and clamping force (EF) data for a typical manual clamp. The clamping force (EF) is expressed as a ratio of the force that is applied to the clamp handle (AF). In this example, either 10:1 or 5.3:1 depending upon position of the clamping point on the clamp arm. That is, at position X1, the maximum clamping force (EF) that can be generated is 10 times the force that is applied to the clamp handle.

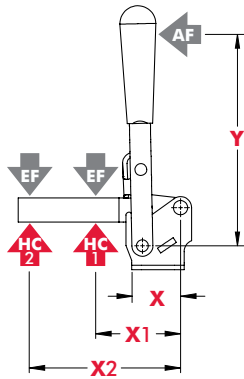

Model	X	X1	X2	Y	±HC1	±HC2	±EF(X1):AF	±EF(X2):AF
2007-( )	[1.59] 40,5	[1.95] 49,5	[3.92] 99,5	[5.16] 131	[1000lbf.] 4450N	[470lbf.] 2090N	10:1	5.3:1

Dimensions shown "mm [inch]" ± HC = Holding Capacity, EF = Exerting Force, AF = Applied Force  
Refer to page MC-TEC-4 for additional information.

### Examples:

- Find the force (AF) the operator would have to apply to the clamp to generate a clamping force of 400N [90lbf.] at the end of the clamp arm (X1).

$$AF = 400 \div 10 = 40N [9lbf.]$$

- What is the maximum clamp force that can be generated at X2 if the operator is only able to apply 20N [4.5lbf.] to the clamp handle?

$$EF = 20 \cdot 5,3 = 106N [24lbf.]$$

### Calculating Holding Capacity

The holding capacity (HC) ratings shown in the table are in relation to the pivot point of the clamping arm. This is useful in estimating the holding capacity at an intermediate clamping point along the arm, or at a point beyond the length of the standard clamping arm.

### Examples:

- Find the maximum holding capacity if the clamping point is 40mm [1.5in.] from the front of the base of the clamp.
  - Step 1 – find the clamping distance from the clamping point to the pivot point

$$X_c = 40mm + X = 40mm + 40,5mm = 80.5mm$$

- Step 2 – express the holding capacity as a moment

$$M = X1 \cdot HC1 = 49,5mm \times 4450N = 220275 \text{ N}\cdot\text{mm}$$

- Step 3 – calculate the holding capacity at Xc

$$HC = M \div X_c = 220275 \div 80,5 = 2736N [615lbf.]$$

- Find the maximum holding capacity if the clamp arm is extended by 25mm [1in.]

$$X_c = 25+X2 = 25 + 99,5 = 124,5mm$$

$$M = X2 \cdot HC2 = 99,5mm \cdot 2090mm = 207955 \text{ N}\cdot\text{mm}$$

$$HC = M \div X_c = 207955 \div 124,5 = 1670N [375lbf.]$$

# TECHNICAL APPENDIX

## General Specifications

Material, finishes, treatments, etc. of DESTACO products are changed from time-to-time to improve performance or reliability. These items are, naturally, subject to change without notice. In the interest of catalog longevity, they are not discussed in detail throughout the catalog. As of the date of going to press, however, the following specifications apply unless noted otherwise:

### Materials

In general, light and medium duty clamp components are made from low carbon cold-rolled steel. Materials for other models vary depending upon the clamp model and specific engineering requirements. These materials include low to medium carbon steel castings and forgings, heat treated as necessary to obtain the desired mechanical properties.

Pivot pins for most light and medium duty clamps are cold headed from precision cold drawn type 430, EN 1.4016 stainless steel. Pins for heavy duty models are made from heat treated alloy steel. Bushings used in select models are made from low carbon, case-hardened steel for wear resistance and serrated on the outside diameter to prevent rotation.

Ergonomic grips are made from an oil-resistant plasticized PVC compound, while some handles and locking levers covered with plastisol dipping.

### Stainless Steel

Stamped components in our stainless steel clamps are made from type 302/304, 1.4300 or 1.4301 (or comparable) stainless steel, annealed & cold rolled. Machined stainless steel components are type 303, EN1.4305 (or comparable).

### Finishes

Most manual toggle clamps are electro-plated zinc per ASTM B633-98, SC1, type2 (or comparable). Most cast or forged components are finished black oxide with light oil to add corrosion protection.

### Mounting

To properly secure the clamp to the mounting surface and achieve the clamp's rating, all mounting holes provided must be used.

### Modifications

Making changes to the clamp may affect the performance of the product. The life expectancy of a clamp is dependent upon many factors, including alterations to the clamping bar, handle, or the addition of any tooling. Manual clamps are rated using hand power to actuate them. The use of "cheater bars" or hammers to impact the opening or closing of the clamp is expressly prohibited.

### Maintenance

Manual clamps are generally maintenance free; however, lubrication of pivot points will extend the life of the clamp dramatically. Clamps are shipped from the factory with a light coating of oil, occasional lubrication with a lightweight machine oil at pivot points is recommended. A typical oil specification is ISO grade 22 or 46 (SAE No. 10W or 20).

### Temperature Limits

DESTACO manual clamps are intended to be used at normal ambient temperatures. These limits are intended to be guidelines and you should contact DESTACO if you have a specific application concern. For low-carbon steel clamps: -65°F(-54°C) to 480°F(250°C); for stainless steel (type 304): up to 750°F (400°C). These values are based upon maintaining the tensile strength of the material, due to the many variables associated with operating clamps at elevated temperatures service life may be affected. Bear in mind that for low carbon steel parts that are zinc plated, the plating has a useful service temperature of up to 250°F(120°C), but corrosion inhibiting properties degrade above 140°F(60°C). These temperatures are NOT inclusive of any plastic grip, vinyl dipping, rubber spindle accessory, pneumatic, or hydraulic actuator.



# TECHNICAL APPENDIX

## Pneumatic Clamping Technology

### End position sensing of pneumatic clamps for automated production.



Model 807-S with 2 integral groove mounted sensors (order separately)

### Exerting Force vs. Holding Capacity

Due to the nature of the toggle action within the clamping mechanism combined with the line pressure of the cylinder, care should be taken in setting up Pneumatic Toggle Clamps.

The clamping force of a given pneumatic toggle clamp is determined by two factors - adjustment of the clamping spindle and the line pressure in the cylinder. If the line pressure remains constant, then the clamping force is solely determined by the vertical adjustment of the spindle. If the spindle is improperly adjusted, the clamp is capable of creating a clamping force that exceeds the rated holding capacity.

As a result of this condition care must be taken by properly adjusting the spindle OR by regulating the inlet pressure to the cylinder in order to insure the clamp does not exert a force higher than it's rated holding capacity.

Please consult the table and formulae on the next page. The Max M.A. is the highest mechanical advantage the clamp can create at the optimum spindle height while still toggle-locking.

### Remote control and end position sensing

A particularly interesting advantage of DESTACO power clamps is the fact that they may be mounted on rather inaccessible places of clamping fixtures and they may be operated simultaneously while being controlled by a control valve. Power clamps with an end position sensing system allow fully automated operation within controlled manufacturing processes.

### Safety

DESTACO power clamps are based on the toggle action principle (exceptions will be mentioned separately) and offer the same safety advantages as DESTACO manual clamps: no risk of accidental opening of the clamp arm - even in case of a sudden pressure drop.

The toggle action principle with over-center locking guarantees safety during operation and protects the parts from damage. (Provided that the power clamps are mounted correctly and the air supply is reliable.)

**Note:** Most pneumatic products are now supplied with a magnetic ring on the piston as a standard feature for sensing the position of the cylinder (open/closed).

### Pneumatic diagram

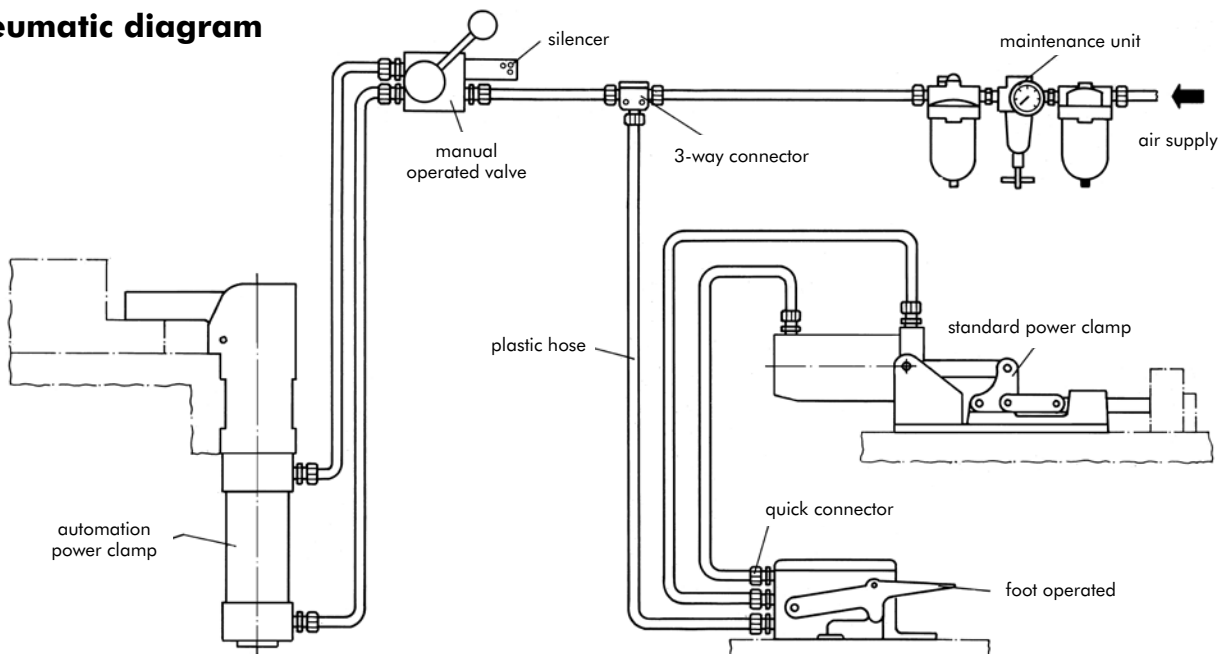

# TECHNICAL APPENDIX

## Specifications

Model no.	Cylinder Bore		Rod Diameter		Cylinder Area (Clamping Stroke)		Cylinder Area (Opening Stroke)		Max. Mechanical Advantage (M.A.)		Distance From Pivot				Holding Capacity				Max Inlet Pressure at Max M.A.*				Max. Clamping Force at 5 bar [72 psi]			
	(in)	(mm)	(in)	(mm)	(in <sup>2</sup> )	(mm <sup>2</sup> )	(in <sup>2</sup> )	(mm <sup>2</sup> )	A	B	A		B		A		B		A		B		A		B	
											(in)	(mm)	(in)	(mm)	(lbf.)	(N)	(lbf.)	(N)	(PSIG)	(bar)	(PSIG)	(bar)	(lbf.)	(N)	(lbf.)	(N)
<b>Hold Down Clamps</b>																										
802-U	1.26	32	0.47	12	1.25	804	1.07	691	5.0	2.6	1.25	31.8	2.25	57.2	200	890	110	489	32	2.2	34	2.3	450	2010	234	1045
807-S	1.26	32	0.47	12	1.25	804	1.07	691	6.0	2.0	2.00	50.8	5.00	127.0	500	2220	260	1160	67	4.6	104	7.2	540	2412	180	804
807-U	1.26	32	0.47	12	1.25	804	1.07	691	6.4	3.3	2.00	50.8	3.75	95.3	375	1670	275	1220	47	3.2	67	4.6	576	2573	297	1327
810-S	1.57	40	0.63	16.0	1.95	1257	1.64	1056	5.0	2.9	2.38	60.5	5.31	134.9	750	3340	500	2220	77	5.3	89	6.1	702	3143	407	1823
810-U	1.57	40	0.63	16.0	1.95	1257	1.64	1056	6.1	2.9	2.38	60.3	4.88	123.8	600	2670	290	1290	50	3.5	51	3.5	856	3834	407	1823
812-U	0.75	19	0.25	6.4	0.4	258	0.39	253	4.3	2.9	1.25	31.8	2.25	57.2	100	440	55	245	53	3.6	43	3.0	136	613	92	413
846	1.57	40	0.63	16.0	1.95	1257	1.64	1056	5.6	3.5	2.25	57.2	3.25	82.6	750	3340	520	2310	69	4.7	76	5.3	786	3520	491	2200
847-S	2.05	50	0.63	16.0	3.29	2124	2.98	1923	4.0	1.8	3.25	82.6	6.50	165.1	1000	1118	650	2890	76	5.2	110	7.6	948	4248	426	1912
847-U	2.05	50	0.63	16.0	3.29	2124	2.98	1923	4.0	1.9	3.25	82.6	6.25	158.8	1000	4450	480	2135	76	5.2	77	5.3	948	4248	450	2018
858	2.48	63	0.98	25.0	4.83	3117	4.07	2626	4.4	2.3	3.00	76.2	7.00	177.8	4000	17800	2000	8900	145**	10.0**	145**	10.0**	1530	6857	800	3585
8021	1.26	32	0.47	12.0	1.07	691	1.25	8.4	2.2	1.3	1.70	43.2	2.60	66.0	390	1735	255	1135	145**	10.0**	145**	10.0**	169	760	100	449
8071	1.57	40	0.63	16.0	1.64	1056	1.95	1257	4.2	2.4	2.25	57.2	3.25	82.6	450	2000	310	1380	65	4.5	79	5.4	496	2218	283	1267
8101	2.05	50	0.63	16.0	2.98	1923	3.29	2124	2.3	1.2	2.35	59.7	4.45	113.0	700	3110	370	1645	103	7.1	105	7.3	491	2202	253	1135
817-S	1.26	32	0.47	12.0	1.25	804	1.07	691	4	2.25	2.75	69.9	4.94	125.5	450	2000	200	890	90	6.2	64	4.4	360	1608	225	1005
817-U	1.26	32	0.47	12.0	1.25	804	1.07	691	4.1	2.5	2.75	69.9	5.00	127.0	375	1670	200	890	73	5.1	64	4.4	369	1648	225	1005
827-S	1.57	40	0.63	16.0	1.95	1257	1.64	1056	3.5	2	2.50	63.5	5.30	134.6	700	3110	330	1470	103	7.1	85	5.8	491	2200	281	1257
827-U	1.57	40	0.63	16.0	1.95	1257	1.64	1026	3.5	2.2	2.13	54.1	3.25	82.6	600	2670	390	1735	88	6.1	91	6.3	491	2200	309	1383
868	2.48	63	0.98	25.0	4.83	3117	4.07	2626	4.9	2.3	5.00	127.0	8.25	209.6	4000	17800	2400	10675	145**	10.0**	145**	10.0**	1704	7637	800	3585

Model no.	Cylinder Bore		Rod Diameter		Cylinder Area (Clamping Stroke)		Cylinder Area (Opening Stroke)		Max. Mechanical Advantage (M.A.)	Holding Capacity		Max Inlet Pressure at Max M.A.			
	(in)	(mm)	(in)	(mm)	(in <sup>2</sup> )	(mm <sup>2</sup> )	(in <sup>2</sup> )	(mm <sup>2</sup> )		(lbf.)	(N)	(PSIG)	(bar)		
<b>Straight Line Action Clamps</b>															
803	1.26	32.0	0.47	12.0	1.25	804	1.07	691.2	7.5	600	2670	64	4.4	675	3015
816	0.75	19.1	0.25	6.4	0.44	285	0.39	253.4	7.7	100	400	30	2.0	244	1097
830	1.57	40.0	0.63	16.0	1.95	1257	1.64	1055.6	5.7	2500	11100	145**	10.0**	800	3582
850	2.05	52.0	0.63	16.0	3.29	2124	2.98	1922.7	5.2	16000	71200	145**	10.0**	1232	5522
8031	1.13	28.6	0.38	9.5	0.99	641	0.88	570.0	10.25	2000	890	145**	10.0**	731	3285

\* Maximum cylinder pressure is 145 PSIG (10 bar). Never exceed this value

\*\*Maximum inlet pressure in conjunction with maximum mechanical advantage does not exceed holding capacity. Do not exceed maximum cylinder pressure

### Formula for calculating maximum allowable inlet pressure:

$$\text{Maximum Line Pressure} = \text{Holding Capacity} \div (\text{Cylinder Area} \times \text{Mechanical Advantage})$$

### Formula for calculating max. exerting force:

$$\text{Exerting Force} = \text{Inlet Pressure} \times \text{Mechanical Advantage} \times \text{Cylinder Area}$$

### Example for Model 830

Holding Capacity = 11100N [2500lbf.]

Inlet Pressure 5bar (0,5 N/mm<sup>2</sup>) [72psig]

Cylinder Area = 1257mm<sup>2</sup> [1.95in<sup>2</sup>]

Maximum Line Pressure = 11100 ÷ (1257 X 5.7) = 1,5 N/mm<sup>2</sup> = 15bar

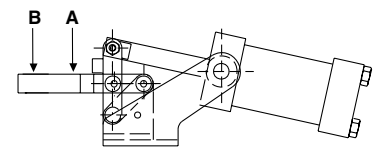



Spindle position to determine mechanical advantage.





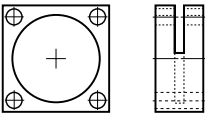
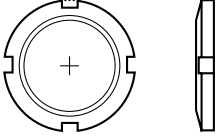

**NOTE:** This exceeds the maximum allowable cylinder pressure of 10bar



# HYDRAULIC POWER CLAMPS

## Table of Contents

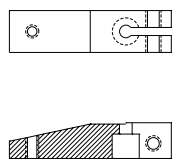
Hydraulic Clamping		Page MC-HYD-#
	010-210-400	3-4
	010-210-501	
	010-210-702	
	010-211-002	
	010-211-004	
	010-211-502	
	010-211-504	
	010-212-004	
	052-Series	4
	051-Series	4
	020-011-011DE	5
	020-012-021DE	
	020-013-031DE	

Hydraulic Clamping		Page MC-HYD-#
	030-1-S-475	7
	030-1-D-475	
	030-1-S-1100	8
	030-1-D-1100	
	030-1-S-2400	9
	030-1-D-2400	
	030-1-S-4000	10
	030-1-D-4000	10
	031-S-475	11-12
	031-L-475	
	031-S-1100	
	031-L-1100	
	031-S-2400	
	031-L-2400	
	031-S-4000	
	031-L-4000	
	039-101-000DE	13
	039-104-000DE	

# BUILDING SAFE HYDRAULIC SYSTEMS

## Hydraulic Power Clamps | Safety

**Safety** means paying attention to the smallest details. A hastily assembled workholding system can result in a hazardous operator environment. Hydraulic workholding is not a generic technique where most anything will work, nor is there one right or best answer for all situations. Each application is different and can be approached in many different ways. Because of this versatility, there is no rule-of-thumb to follow to guarantee safety. A careful balance of knowledge, fixture design and common sense are key to avoiding injuries.

**Plan** your fixture installation with operator safety in mind. By nature, most clamping devices have pinch points. Many times the fixture can be designed to shield the operator from a pinching hazard. Often the placement of the clamping device in the fixture can minimize the gap between the clamp and the workpiece, thus reducing or eliminating the pinch point. Perhaps the clamping control valve or switch can be located such that the operator cannot reach the fixture and the control at the same time. Dual palm buttons on electrically-actuated systems serve the same purpose.

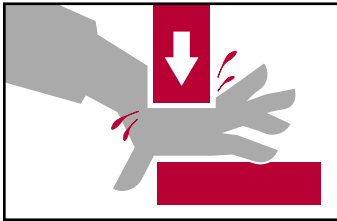

**Do not** require the operator to hold the workpiece in position during the clamping operation. Make sure that the workpiece is self-supporting and self-locating so that operator hands are out of

danger when the hydraulic system is actuated. Often a simple spring plunger is all that is necessary.

The lowest pressure rating of any component in the clamping system sets the *maximum* pressure rating for the entire system.

Most hydraulic workholding components are rated at 5,000 PSI maximum.

However, some components are rated at less than 5,000 PSI. The maximum pressure is listed on each product page of this catalog. *Never exceed this rating.*

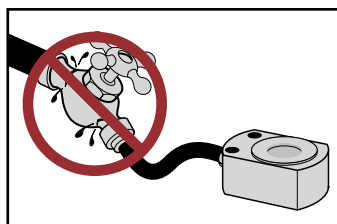

Just having a clamp that is rated at 5,000 PSI is not enough. Every hose, fitting, valve, adapter and tube exposed to pressure must be rated at or above the maximum hydraulic system pressure. Most

“hardware store” fittings are intended only for low pressure plumbing. *Never use water pipe fittings or copper tubing and brass fittings for hydraulic service.*

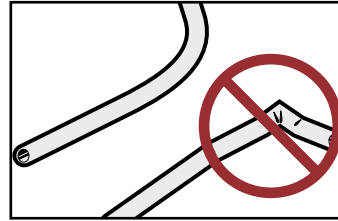

Use proper tools when bending tubing, and maintain proper minimum bend radii for hoses and tubing. If a hose or tube is ever kinked, replace it. Don't risk a rupture. Fluid escaping

under high pressure is dangerous. The resulting loss in pressure could release the workpiece from the fixture and cause serious injury and equipment damage by being ejected from the machine or breaking tooling.

Tubing and hoses do flex when pressurized. Allow for that movement by supporting the fluid lines away from surfaces which could abrade the surface and eventually cause damage. Avoid straight lengths of hose and tubing. A bend will allow for this deflection without putting too much stress on the line.

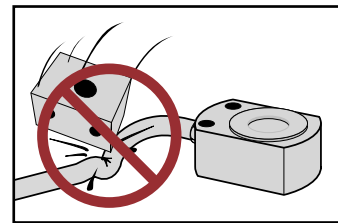
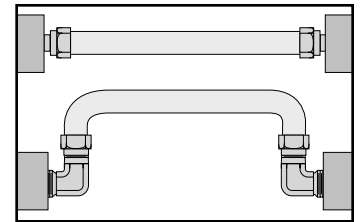

Even if proper hydraulic tubing and fittings are specified, be sure to protect them from abuse. Components damaged from abrasion or accidental dropping of a workpiece will no longer

have the strength and safety of the original design.

Use **proper mounting hardware** when installing workholding clamps and other components. Always use the largest bolt available to fit in the mounting hole. In many cases, the recommended cap screw or thread is specified on the product page of this catalog. Sometimes the mounting hardware is included with the component. Always use supplied hardware.

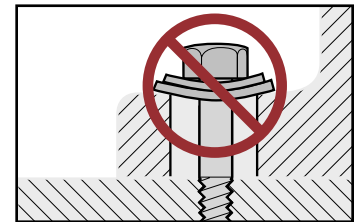

**Safety means  
paying attention to  
the smallest details.**

# 010 SERIES

## Hydraulic Power Clamps | Hydraulic Threaded Body Cylinders Product Overview

The single-action, spring-return hydraulic power cylinders are small pistons that can be used singly or combined. They offer tremendous force in a small, easily mounted package that can be used in any attitude and requires only a single inlet port. They are often used grouped together by a common manifold to provide as much force as needed for the operation. For a relatively small volume of oil, they provide exceptional exerting force, and are generally the best choice if stroke lengths can be kept short.



### Features:

- Threaded body for easy mounting
- Small size permits "low profile" workholding
- Accessories available for easy mounting
- Available in metric or inch sizes (Metric on special request)
- Hardened piston and rod
- Single-acting for simple plumbing
- Wide variety of sizes and strokes
- Pressure capacity up to 5,000 PSIG, provided piston does not bottom out

### Technical Information

Model no.	SAE Ports	Threaded Body	Stroke	Force at 3,000 PSIG	Oil Displacement	Effective Area For Clamping	Jam Nuts
010-210-400	#2	1/2-20	0.22	277 lbs.	0.020 cu. in.	0.092	Furnished
010-210-501	#4	3/4-16	0.31	588 lbs.	0.061 cu. in.	0.196	Furnished
010-210-702	#4	1-12	0.50	1,326 lbs.	0.221 cu. in.	0.442	Furnished
010-211-002	#4	1 5/16-16	0.50	2,355 lbs.	0.393 cu. in.	0.785	Optional
010-211-004	#4	1 5/16-16	1.00	2,355 lbs.	0.785 cu. in.	0.785	Optional
010-211-502	#4	1 7/8-16	0.50	5,301 lbs.	0.884 cu. in.	1.767	Optional
010-211-504	#4	1 7/8-16	1.00	5,301 lbs.	1.767 cu. in.	1.767	Optional
010-212-004	#4	2 1/2-16	1.00	9,423 lbs.	3.142 cu. in.	3.142	Optional

## Hydraulic Power Clamps | Hydraulic Threaded Body Cylinders Product Overview

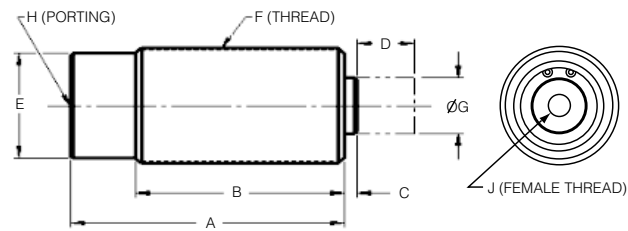

Model no.	Dimensions (In Inches)								
	A	B	C	D	E	F	G	H	J
010-210-400	1.66	1.41	0.19	0.22	.044 Hex	1/2-20	0.15	SAE #2	-
010-210-501	2.25	1.97	0.22	0.31	.062 Hex	3/4-16	0.22	SAE #4	-
010-210-702	2.56	2.31	0.31	0.50	.075 Hex	1-12	.024	SAE #4	-
010-211-002	2.63	2.25	0.13	0.50	1.00 Hex	1 5/16-16	0.64	SAE #4	1/4-20
010-211-004	3.63	3.25	0.12	1.00	1.00 Hex	1 5/16-16	0.64	SAE #4	1/4-20
010-211-502	2.94	2.57	0.13	0.50	1.50 Hex	1 7/8-16	1.00	SAE #4	5/16-18
010-211-504	4.59	4.22	0.14	1.00	1.50 Hex	1 7/8-16	1.00	SAE #4	5/16-18
010-212-004	4.13	3.76	0.13	1.00	2.00 Hex	2 1/2-16	1.50	SAE #4	5/16-18

### Series 052 Flange Mount

Model no.	Dimensions (In Inches)				
	A	B	C	øD	E
052-112-160	1 1/8-16 UN 2B	1.50	0.50	0.22	1.030
052-131-160	1 5/16-16 UN 2B	1.69	0.50	0.27	1.250
052-137-180	1 3/8-16 UN 2B	1.75	0.50	0.27	1.340
052-187-160	1 7/8-16 UN 2B	2.25	1.00	0.34	1.770
052-250-160	2 1/2-16 UN 2B	3.00	1.00	0.34	2.170

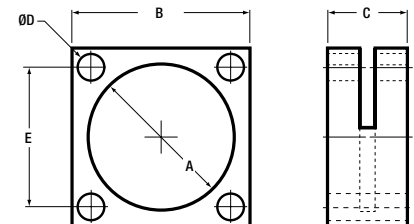

### Series 051 Jam Nut

Model no.	Dimensions (In Inches)				
	A	B	C	D	E
051-112-160	1 1/8-16 UN 2B	1.500	0.31	0.250	0.250
051-131-160	1 5/16-16 UN 2B	1.688	0.31	0.250	0.250
051-137-180	1 3/8-16 UN 2B	1.875	0.31	0.250	0.250
051-187-160	1 7/8-16 UN 2B	2.625	0.38	0.312	0.132
051-250-160	2 1/2-16 UN 2B	3.250	0.50	0.312	0.312

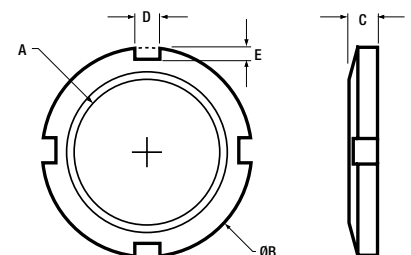

# 020 SERIES

## Hydraulic Power Clamps | Thru-Hole Hydraulic Ram Product Overview

By inserting a rod through the hollow piston, these cylinders can be used to push or pull depending on the orientation of the ram. They will actuate a rod of any length or shape and are extremely effective in translating power to a remote location. Greater forces are generated in these thru-hole rams because of their larger piston area.

### Features:

- Larger piston diameter for greater clamping forces
- Hardened steel piston and rod
- Single-acting for simple plumbing
- Optional threaded inserts
- Optional mounting plate (permits mounting ram with a single cap screw)



Symbol

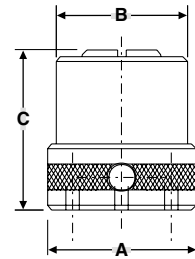
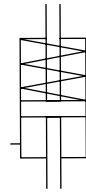

Model no.	RAM I.D.*	Port	Stroke	Force at 3,000 PSIG	Oil Displacement	Dimensions		
						A	B	C
<b>020-011-011DE</b>	0.38	SAE #2	0.38	4,380 lbs.	0.547 cu. in.	2.13	1.88	2.25
<b>020-012-021DE</b>	0.50	SAE #4	0.50	8,100 lbs.	1.35 cu. in.	3.00	2.63	2.88
<b>020-013-031DE</b>	0.63	SAE #4	0.63	12,066 lbs.	2.51 cu. in.	3.25	3.00	3.63

\* Clearance for rod or bolt of given dimension.

Maximum input pressure 3,500 PSIG.

### Accessories

All size thru-hole rams are supplied with a thru-hole insert threaded into the top.

RAM no.	Thru-Hole Insert (supplied)
<b>020-011-011DE</b>	705384
<b>020-012-021DE</b>	705512
<b>020-013-031DE</b>	705634

Loads Transmitted by Various Diameter Screws		
Bolt Size	Wrench Length	F-lbs. (Average)
1/4 UNF	4.00	2,400 lbs.
1/4 UNF	4.00	1,920 lbs.
3/8 UNF	5.75	3,000 lbs.
3/8 UNF	5.75	2,920 lbs.
1/2 UNF	8.00	4,200 lbs.
1/2 UNF	8.00	3,640 lbs.
5/8 UNF	9.00	5,600 lbs.
5/8 UNF	9.00	5,600 lbs.
3/4 UNF	9.00	4,800 lbs.
3/4 UNF	11.00	4,200 lbs.
7/8 UNF	12.00	50,400 lbs.

To determine how much force is needed to replace a manual clamp, use this chart as a guide.

A thru-hole ram easily converts a manual strap clamp into an automatic hydraulic powered clamp. Usually a longer bolt is the only part needed to make this conversion.

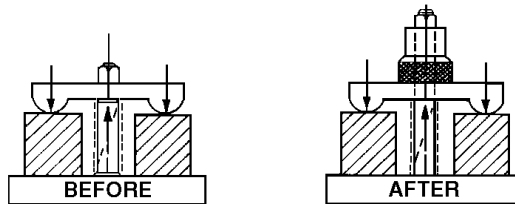



### Calculation of Forces Using Straps and Levers

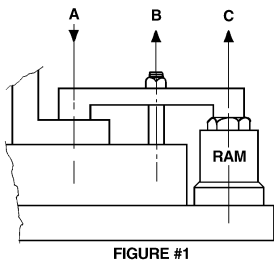

FIGURE #1

#### Figure #1

When the distance AB is equal to the distance BC the force upward from Model 020-011-011DE Ram "C" is equal to the downward force "A" on the part.

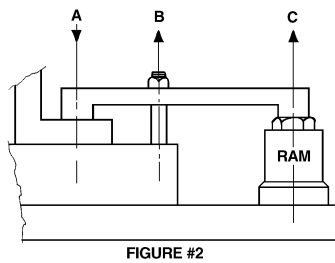

FIGURE #2

#### Figure #2

The downward force "A" is equal to the upward force "C" times a ratio of the distance BC:AB.

#### Example:

AB = 2", BC = 4", Force "C" = 1,000 lbs.

$$\text{Force "A"} = \text{Force "C"} \times \frac{BC}{AB}$$

$$\text{"A"} = 1,000 \text{ lbs.} \times \frac{4}{2}$$

$$\text{"A"} = 2,000 \text{ lbs.}$$

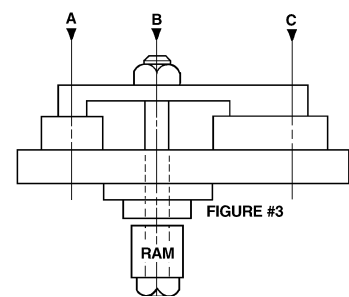

FIGURE #3

#### Figure #3

When Force "B" from Model 020-011-011DE Hollow Bore is divided between "A" & "C", the forces at "A" & "C" are in inverse ratio to the distance AB & BC respectively.

$$\text{Force "A"} = \text{Force "B"} \times \frac{BC}{AB}$$

$$\text{Force "C"} = \text{Force "B"} \times \frac{AB}{AC}$$

#### Example:

AB = 2", BC = 4," Force "B" = 1,000 lbs.

$$\text{Force "A"} = 1,000 \text{ lbs.} \times \frac{4}{6} = 666.7 \text{ lbs.}$$

$$\text{Force "C"} = 1,000 \text{ lbs.} \times \frac{2}{6} = 333.3 \text{ lbs.}$$

### Power Sources

Thru-hole Rams can be powered by automatic pumps, hand pumps, boosters or existing machine hydraulics.

#### Used with automatic pump

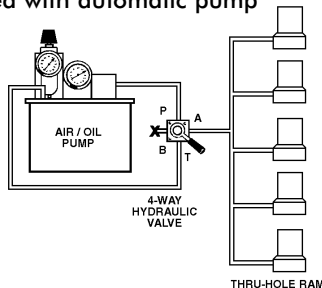

#### Used with hand pump

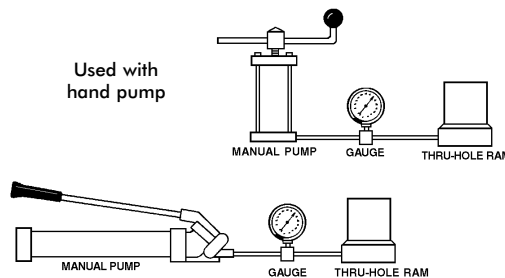

#### Used with booster

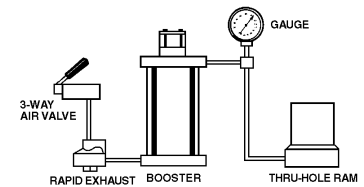

### Multiple Uses

Thru-hole Rams can be used to push or pull depending on the position of the ram.

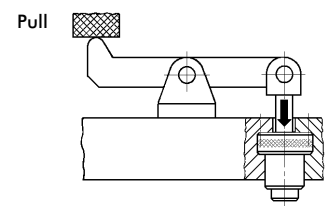
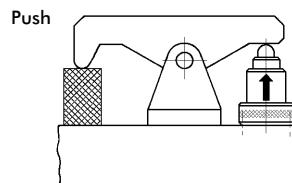
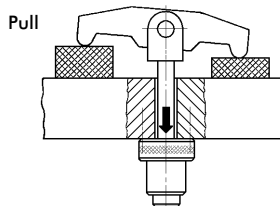
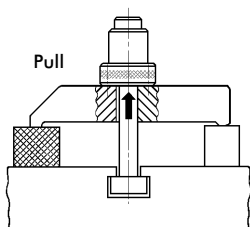

# 030 SERIES

## Hydraulic Power Clamps | Hydraulic Swing Clamps – 475 lb.

The DESTACO Threaded Body Swing Clamps are available in both single-acting and double-acting versions. They incorporate the latest hydraulic swing clamp technology. The top port design allows easy access for plumbing connections.

They are available with 90° left or right hand rotation. The breather port on single-acting models may be replaced with tubing for remote venting. The optional arms clamp securely to the piston rod to reduce fatigue and deflection. Arms may be easily modified or custom arms may be substituted.

### Features:

- Advanced seals and wipers utilize a special, highly wear-resistant construction for long cycle life and 5,000 PSI operation
- Triple track piston rod design for field adjustable swing direction
- Hardened and hard chrome plated piston rod for increased strength and wear resistance
- Advanced metal treated body for superior wear and corrosion resistance
- MRO interchange design

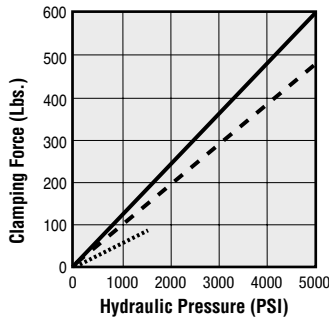
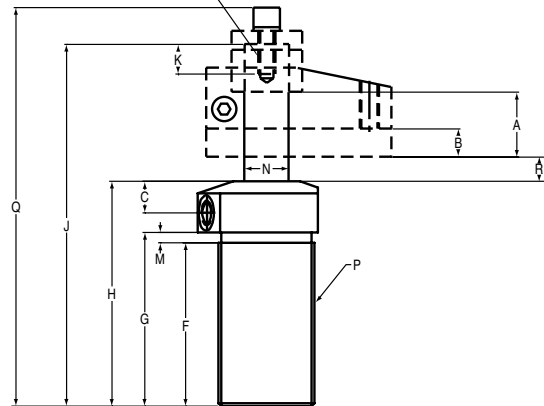
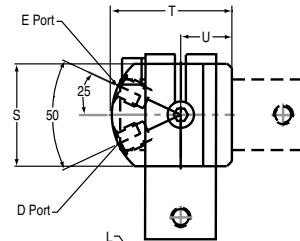
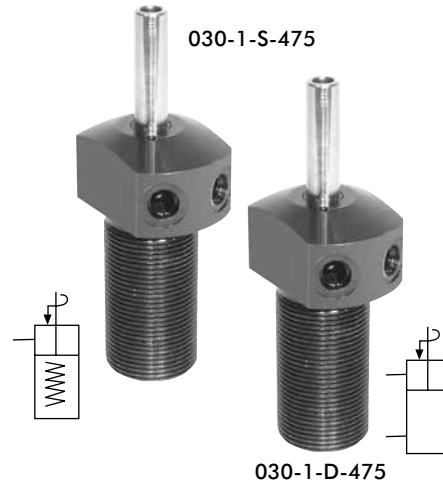

### Performance

- ..... With 031-L-475 Arm (3.25" long)
- - - With 0-31-S-475 Arm (1.22" long)
- Straight Pull

For 475 lb. Swing Clamp Arms see Page MC-HYD-11

Cat. no.	Specifications							Max Oil Flow in <sup>3</sup> /m in
	Oper.	Swing Direction	*Force (lbs.)	Eff. Area (sq. In.) Clamp Unclamp	Oil Cap. (cu. In.) Clamp Unclamp			
030-1-S-475 (-X) †	Single-Acting	Left Hand (Counter Clockwise)	475	0.12	—	0.08	—	12
030-1-D-475 (-X) †	Double-acting	Right Hand (Clockwise)			0.24		0.15	

- Ordering Notes:
- Left hand swing (ccw) is standard—no suffix
  - Add -R suffix for right hand swing

Cat. no.	Specifications																			
	A Total Stroke	B Clamping Stroke	C	D Clamp Port	E Unclamp Port	F	G	H	J	K	L	M	N	P	Q	R	S	T	U	
030-1-S-475 †	0.65	0.210	0.59	SAE-2	SAE-2	1.929	2.086	3.07	4.429	0.8	M6x1	0.157	0.393	1-1/8-16UN	4.96	0.495	1.3	1.55	0.61	
030-1-D-475 †	0.65	0.32	0.59																	

† This item is available upon request

NOTE: \*With 1.22" long arm at 5,000 PSI maximum operating pressure.  
 ‡ Do not pressurize – single-acting only  
 † See page MC-HYD-11 for arms, accessories and custom arm mounting

## Hydraulic Power Clamps | Hydraulic Swing Clamps – 1,100lb.

The DESTACO Threaded Body Swing Clamps are available in both single-acting and double-acting versions. They incorporate the latest hydraulic swing clamp technology. The top port design allows easy access for plumbing connections.

They are available with 90° left or right hand rotation. The breather port on single-acting models may be replaced with tubing for remote venting. The optional arms clamp securely to the piston rod to reduce fatigue and deflection. Arms may be easily modified or custom arms may be substituted.

### Features:

- Advanced seals and wipers utilize a special, highly wear-resistant construction for long cycle life and 5,000 PSI operation
- Triple track piston rod design for field adjustable swing direction
- Hardened and hard chrome plated piston rod for increased strength and wear resistance
- Advanced metal treated body for superior wear and corrosion resistance
- MRO interchange design

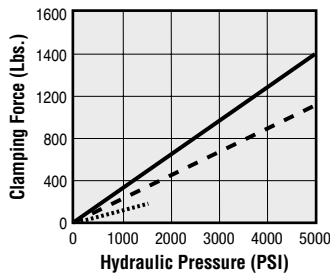

#### Performance

- ..... With 031-L-1100 Arm (5.31" long)
- - - With 031-S-1100 Arm (1.89" long)
- Straight Pull

For 1,100 lb.  
Swing Clamp Arms  
see Page MC-HYD-12

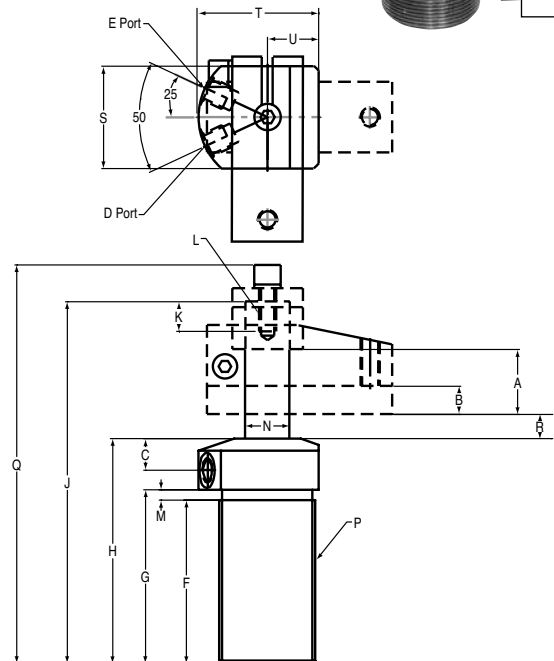
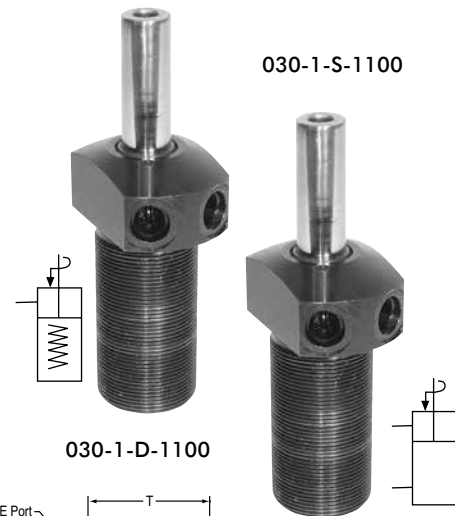

#### Ordering Notes:

- Left hand swing (ccw) is standard—no suffix
- Add -R suffix for right hand swing

Cat. no.	Specifications							Max Oil Flow in <sup>3</sup> /m in
	Oper.	Swing Direction	*Force (lbs.)	Eff. Area (sq. In.) Clamp Unclamp	Oil Cap. (cu. In.) Clamp Unclamp			
030-1-S-1000 (-X) ⓘ	Single-Acting	Left Hand (Counter Clockwise)	1100	0.28	—	0.25	—	25
030-1-D-1000 (-X) ⓘ	Double-acting	Right Hand (Clockwise)			0.59	0.52		

Cat. no.	Specifications																		
	A Total Stroke	B Clamping Stroke	C	D Clamp Port	E Unclamp Port	F	G	H	J	K	L	M	N	P	Q	R	S	T	U
030-1-S-1100 ⓘ	0.89	0.39	0.6	SAE-4	SAE-4	2.4	2.6	3.58	5.305	0.94	M8 x 1.25	0.196	0.629	1-3/8-18UN	5.965	0.400	1.5	1.87	0.75
030-1-D-1100 ⓘ																			

ⓘ This item is available upon request

NOTE: \*With 1.89" long arm at 5,000 PSI maximum operating pressure.  
 †Do not pressurize – single-acting only  
 ‡ See page MC-HYD-12 for arms, accessories and custom arm mounting

# 030 SERIES

## Hydraulic Power Clamps | Hydraulic Swing Clamps – 2,400 lb.

The DESTACO Threaded Body Swing Clamps are available in both single-acting and double-acting versions. They incorporate the latest hydraulic swing clamp technology. The top port design allows easy access for plumbing connections.

They are available with 90° left or right hand rotation. The breather port on single-acting models may be replaced with tubing for remote venting. The optional arms clamp securely to the piston rod to reduce fatigue and deflection. Arms may be easily modified or custom arms may be substituted.

### Features:

- Advanced seals and wipers utilize a special, highly wear-resistant construction for long cycle life and 5,000 PSI operation
- Triple track piston rod design for field adjustable swing direction
- Hardened and hard chrome plated piston rod for increased strength and wear resistance
- Advanced metal treated body for superior wear and corrosion resistance
- MRO interchange design

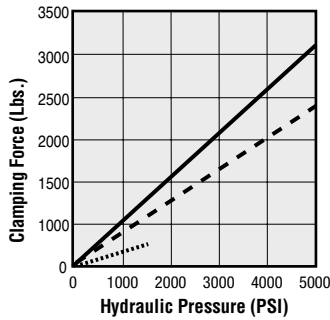

### Performance

- ..... With 031-L-2400 Arm (6.36" long)
- - - - With 031-S-2400 Arm (2.43" long)
- ——— Straight Pull

For 2,400 lb.  
Swing Clamp Arms  
see Page MC-HYD-11

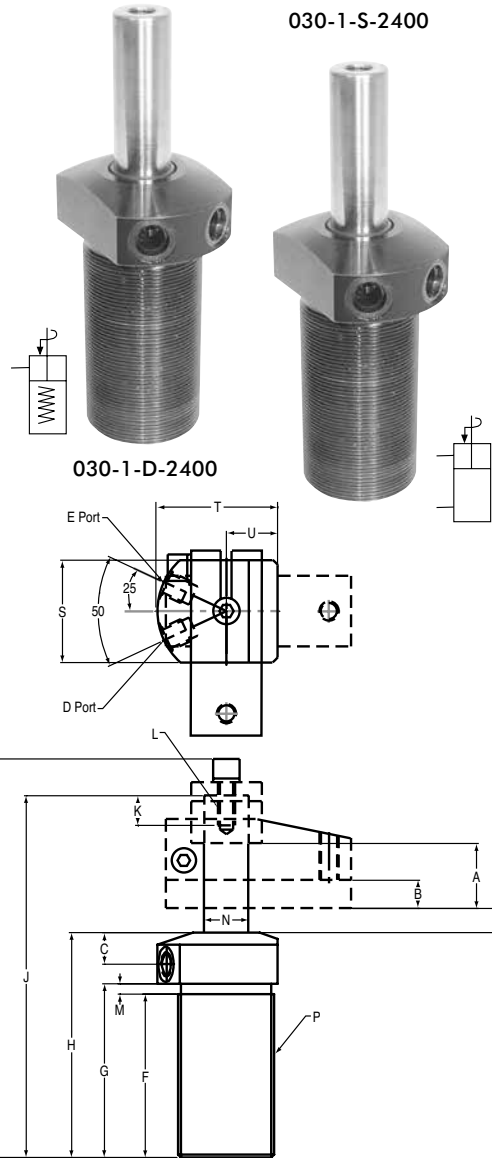

Cat. no.	Specifications								Max Oil Flow in <sup>3</sup> /m in
	Oper.	Swing Direction	*Force (lbs.)	Eff. Area (sq. In.)	Oil Cap. (cu. In.)	Clamp	Unclamp	Clamp	
030-1-S-2400 (-X) ⓘ	Single-Acting	Left Hand (Counter Clockwise) Right Hand (Clockwise)	2400	0.63	0.7	-	-	100	
030-1-D-2400 (-X) ⓘ	Double-acting					1.23	1.10		

### Ordering Notes:

- Left hand swing (ccw) is standard—no suffix
- Add -R suffix for right hand swing

Cat. no.	Specifications																		
	A Total Stroke	B Clamping Stroke	C	D Clamp Port	E Unclamp Port	F	G	H	J	K	L	M	N	P	Q	R	S	T	U
030-1-S-2400 ⓘ	1.12	0.5	0.62	SAE-4	SAE-4	†	3.38	4.38	6.8	1.28	M10x1.5	0.196	0.87	1-7/8-16UN	7.543	0.517	2.0	2.38	1.0
030-1-D-2400 ⓘ																			

ⓘ This item is available upon request

NOTE: \*With 2.43" long arm at 5,000 PSI maximum operating pressure.

‡Do not pressurize – single-acting only

† See page MC-HYD-11 for arms, accessories and custom arm mounting

## Hydraulic Power Clamps | Hydraulic Swing Clamps – 4,000 lb.

The DESTACO Threaded Body Swing Clamps are available in both single-acting and double-acting versions. They incorporate the latest hydraulic swing clamp technology. The top port design allows easy access for plumbing connections.

They are available with 90° left or right hand rotation. The breather port on single-acting models may be replaced with tubing for remote venting. The optional arms clamp securely to the piston rod to reduce fatigue and deflection. Arms may be easily modified or custom arms may be substituted.

### Features:

- Advanced seals and wipers utilize a special, highly wear-resistant construction for long cycle life and 5,000 PSI operation
- Triple track piston rod design for field adjustable swing direction
- Hardened and hard chrome plated piston rod for increased strength and wear resistance
- Advanced metal treated body for superior wear and corrosion resistance
- MRO interchange design

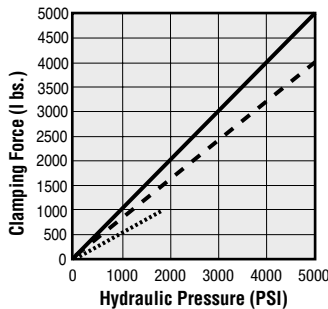
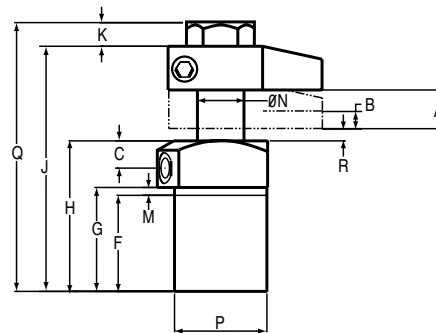
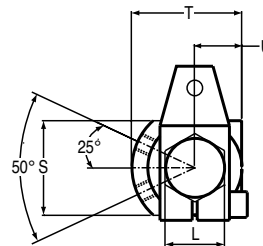

### Performance

- ..... With 031-L-4000 Arm (7.01" long)
- - - With 031-S-4000 Arm (2.75" long)
- Straight Pull

For 4,000 lb.  
Swing Clamp Arms  
see Page MC-HYD-11

Cat. no.	Specifications							Max Oil Flow in <sup>3</sup> /m in
	Oper.	Swing Direction	*Force (lbs.)	Eff. Area (sq. In.) Clamp Unclamp	Oil Cap. (cu. In.) Clamp Unclamp			
030-1-S-4000 (-X) ⓘ	Single-Acting	Left Hand (Counter Clockwise)	4000	1.10	-	1.22	-	140
030-1-D-4000 (-X) ⓘ	Double-acting	Right Hand (Clockwise)		2.35	2.60			

- Ordering Notes:
- Left hand swing (ccw) is standard—no suffix
  - Add -R suffix for right hand swing

ⓘ This item is available upon request

Cat. no.	Specifications																		
	A Total Stroke	B Clamping Stroke	C	D Clamp Port	E Unclamp Port	F	G	H	J	K	L	M	N	P	Q	R	S	T	U
030-1-S-4000 ⓘ	1.07	0.45	0.75	SAE#4	SAE#4	2.70	2.83	4.09	6.67	0.64	1.61	0.14	1.26	2-1/2-16 UN	7.30	0.33	2.56	2.99	1.28
030-1-D-4000 ⓘ																			

ⓘ This item is available upon request

NOTE: \*With 2.75" long arm at 5,000 PSI maximum operating pressure.  
<sup>‡</sup>Do not pressurize – single-acting only  
<sup>†</sup> See page MC-HYD-11 for arms, accessories and custom arm mounting

# 030 SERIES

## Hydraulic Power Clamps | Hydraulic Swing Clamps 475-2,400 lb. Arms

Custom built arms of any length must clamp to the swing clamp's piston rod in a manner similar to the DESTACO arms or some derating of the clamp will be necessary.

The design feature "K," in the chart and drawing at the bottom of this page, is recommended for all applications of custom, single arms. See the accompanying chart for design details. In applications where there is no bending stress being transferred into the piston rod (like push/pull linkages and equalizing double arms), this design detail may be eliminated. In these applications, the clamp's full capacity (referred to as "straight pull" capacity) is available.

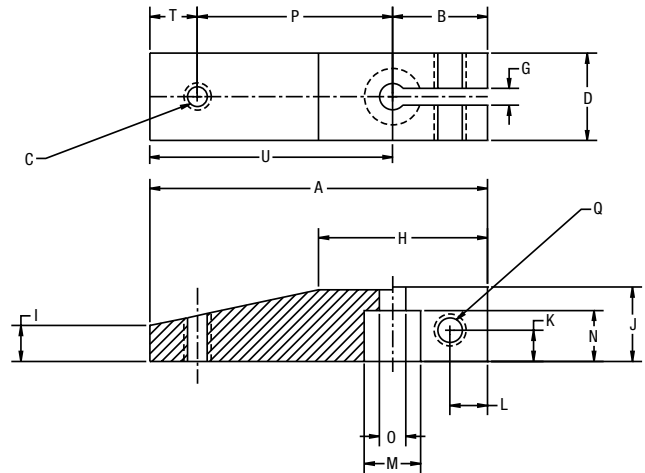

Cat. no.	Specifications																	Weight (lbs.)	
	A	B	C	D	G	H	I	J	K	L	M	N	O	P	Q	T	U		
031-S-475	1.929	0.709	M6	0.63	0.126	1.139	0.394	0.630	0.236	0.217	0.394	0.394	0.256	0.984	M6	0.236	1.220	0.159	
031-L-475	3.959	0.709	-	0.63		1.166	0.394	0.630			0.394	0.394	0.256	-	M6	-	-	3.250	0.348
031-S-1100	2.598	0.709	M8	0.748		1.294	0.433	0.748			0.630	0.472	0.33	1.575	M6	0.315	1.889	0.286	
031-L-1100	6.019	0.709	-	0.748		1.412	0.433	0.748			0.630	0.472	0.335	-	M6	-	5.310	0.721	
031-S-2400	3.268	0.866	M10	1.125		1.459	0.633	1.00			0.866	0.709	0.413	1.969	M8	0.433	2.402	0.634	
031-L-2400	7.226	0.866	-	1.125		1.696	0.633	1.00			0.866	0.709	0.413	-	M8	-	6.360	1.564	

**IMPORTANT:** Any clamp using a modified or custom arm that is longer or heavier than DESTACO's standard arms must be derated to prevent internal damage.  
 Do not exceed the maximum speed and pressure ratings for DESTACO's standard arms.  
 For maximum hydraulic pressure and speed ratings, see the accompanying charts  
 Do not use meter-out circuitry for controlling double-acting clamp speeds  
 Contact DESTACO if further design assistance is required

### Custom Arm Mounting Dimensions for Swing Clamps

Shaft Dia.	Specifications										
	A	B	C	D	E	F	G	H	J	K	M
10 MM	0.394	0.256	0.63	0.63	0.709	1.26	0.394	0.236	0.217	0.30	M6 x 1.0
16MM	0.630	0.335	0.748	0.748	0.709		0.472	0.236	0.217		M6 x 1.0
22 MM	0.866	0.413	1.00	1.00	0.866		0.709	0.236	0.217		M8 x 1.25

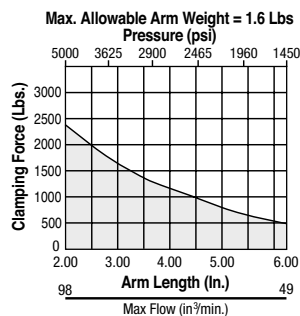
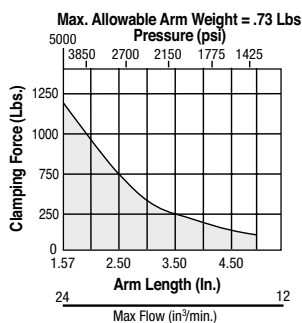
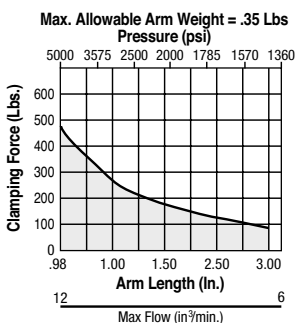
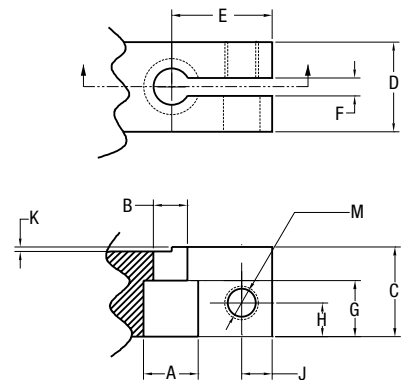

### Chart Legend

- Maximum Length / Pressure
- ▭ Operating Range

Clamps must operate at or below maximum arm length/pressure curve:

To approximate clamping force with any arm at less than maximum pressure:

$$FORCE = P \times A \times [1 - (P/M \times .23)]$$

P = Hyd. system operating pressure (PSI)

A = Clamp effective area (sq. in.)

M = Max. rated pressure of chosen arm length (PSI)

## Hydraulic Power Clamps | Hydraulic Swing Clamps – 4,000 lb. Arms

Custom built arms of any length must clamp to the swing clamp's piston rod in a manner similar to the DESTACO arms or some derating of the clamp will be necessary.

The design feature "K," in the chart and drawing at the bottom of this page, is recommended for all applications of custom, single arms. See the accompanying chart for design details. In applications where there is no bending stress being transferred into the piston rod (like push/pull linkages and equalizing double arms), this design detail may be eliminated. In these applications, the clamp's full capacity (referred to as "straight pull" capacity) is available.

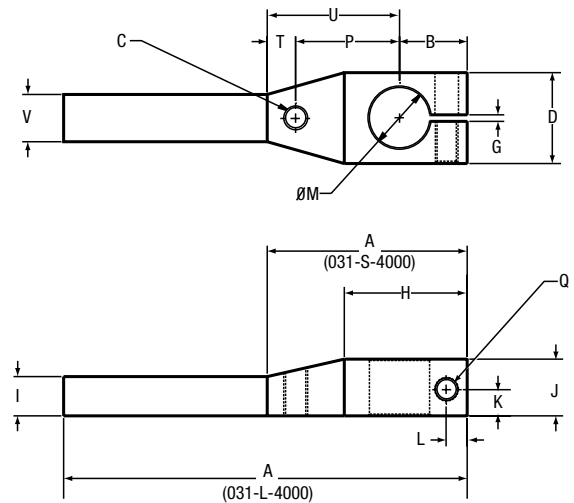

Cat no.	Specifications																Weight (lbs.)
	A	B	C	D	G	H	I	J	K	L	M	P	Q	T	U	V	
<b>031-S-4000</b>	4.17	1.42	1/2-13	1.89	0.138	2.56	0.83	1.18	0.55	0.43	1.26	2.17	M12	0.58	2.75	0.98	1.80
<b>031-L-4000</b>	8.43	1.42	1/2-13	1.89	0.138	2.56	0.83	1.18	0.55	0.43	1.26	-	M12	-	7.01	0.98	2.80

**IMPORTANT:** Any clamp using a modified or custom arm that is longer or heavier than DESTACO's standard arms must be derated to prevent internal damage.  
 Do not exceed the maximum speed and pressure ratings for DESTACO's standard arms.  
 For maximum hydraulic pressure and speed ratings, see the accompanying charts  
 Do not use meter-out circuitry for controlling double-acting clamp speeds  
 Contact DESTACO if further design assistance is required

### Custom Arm Mounting Dimensions for 4,000 lb. Swing Clamps

Cat no.	Specifications							
	A	B	C	D	E	F	G	H
<b>32MM</b>	1.26	1.18	1.89	1.42	0.138	0.55	0.43	M12 x 1.75

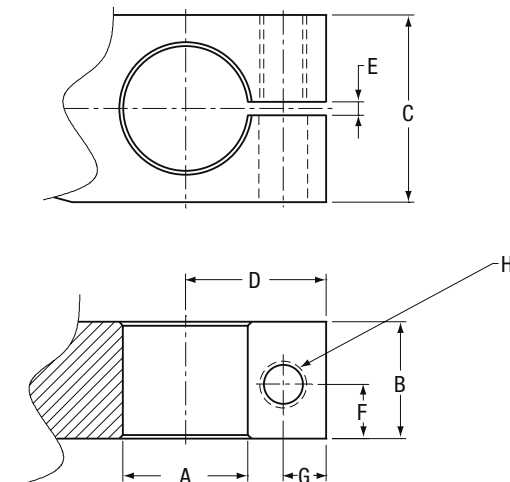

### 031-S-4000 • 031-L-4000

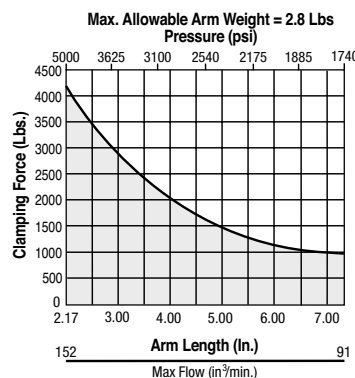

### Chart Legend

- Maximum Length / Pressure
- ▭ Operating Range

Clamps must operate at or below maximum arm length/pressure curve:  
 To approximate clamping force with any arm at less than maximum pressure:

$$FORCE = P \times A \times [1 - (P/M \times .23)]$$

**P** = Hyd. system operating pressure (PSI)

**A** = Clamp effective area (sq. in.)

**M** = Max. rated pressure of chosen arm length (PSI)

# 039 SERIES

## Hydraulic Power Clamps | Air/Hydraulic Power Boosters

The DESTACO Air/Hydraulic Power Booster converts normal shop-line air pressure to high-pressure hydraulic power. The two models available provide oil displacements ranging from 1 cu. in. to 4 cu. in. per stroke.

With the system filled, the volume of oil required to actuate a cylinder or pressure point is only equal to the cubic content of the piston displacement. The small booster, producing 1 cu. in. of usable oil per stroke, can operate 50 of the tiny 1/2-20 pressure points a full .22 max. stroke, and even more when strokes are kept to a minimum.

### Features:

- Built-in manifold
- Complete automatic bleeding with each return stroke
- Automatic relief of system overcharge
- Automatic bleeding feature eliminates pre-filling
- Large volume visible oil reservoir automatically

replenishes the system with reserve oil capacity

- Corrosion and wear-resistant materials
- Wear rings on hydraulic piston tube
- Unique self-centering air piston assures long life
- Increases hydraulic pressure to 3,000 PSIG from 100 PSIG air-line pressure
- All models supplied with SAE hydraulic ports
- NPT hydraulic ports available on request



039-104-000DE

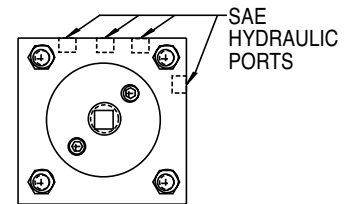
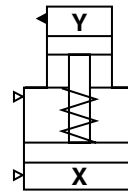

SAE HYDRAULIC PORTS

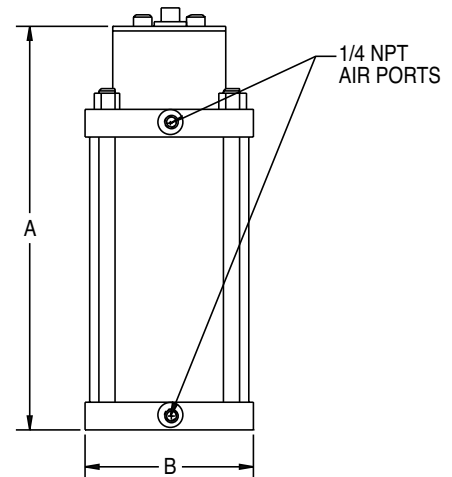

1/4 NPT AIR PORTS

Model no.	Press Ratio	Displacement Per Stroke	Nominal Reservoir Capacity	Weight	Dimensions		Ports
					A	B (Square)	
039-101-000DE	33.87:1	1 cu. in.	10.4 cu. in.	9 lbs.	10.88	4.50	SAE #4
039-104-000DE	32.41:1	4 cu. in.	42 cu. in.	23 lbs.	16.38	6.50	SAE #4

(100 PSIG max. input air pressure)

Note: Special High Temperature Seals available for applications where Viton® Seals are required. Order as H/T option.





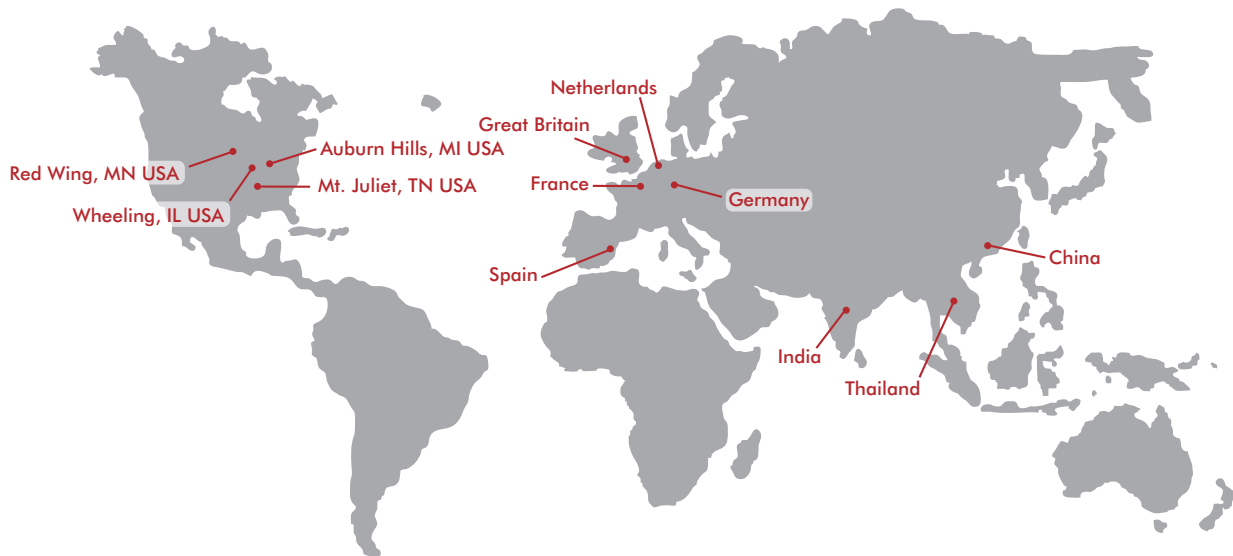

## GLOBAL LOCATIONS

### NORTH AMERICA

#### Corporate Headquarters

Auburn Hills, Michigan  
Toll Free: 1.888.DESTACO  
Marketing: [marketing@destaco.com](mailto:marketing@destaco.com)

#### Global Technology Center

Auburn Hills, Michigan  
Tel: 1.248.836.6700  
Customer Service: [customerservice@destaco.com](mailto:customerservice@destaco.com)

Mt. Juliet, Tennessee  
Tel: 1.888.DESTACO  
Customer Service: [customerservice@destaco.com](mailto:customerservice@destaco.com)

Wheeling, Illinois  
Tel: 1.800.645.5207  
Customer Service: [camco@destaco.com](mailto:camco@destaco.com)

Red Wing, Minnesota (Central Research Laboratories)  
Tel: 651.385.2142  
Customer Service: [sales@centres.com](mailto:sales@centres.com)

### ASIA

Thailand  
Tel: +66-2-326-0812  
Customer Service: [info@destaco.com](mailto:info@destaco.com)

China  
Tel: +86-21-6081-2888  
Customer Service: [china@destaco.com](mailto:china@destaco.com)

India  
Tel: +91-80-41123421-426  
Customer Service: [india@destaco.com](mailto:india@destaco.com)

### EUROPE

Germany  
Tel: +49-6171-705-0  
Customer Service: [europe@destaco.com](mailto:europe@destaco.com)

France  
Tel: +33-4-73545001  
Customer Service: [france@destaco.com](mailto:france@destaco.com)

Great Britain  
Tel: +44-1902-797980  
Customer Service: [uk@destaco.com](mailto:uk@destaco.com)

Spain  
Tel: +34-936361680  
Customer Service: [spain@destaco.com](mailto:spain@destaco.com)

Netherlands  
Tel: +31-297285332  
Customer Service: [benelux@destaco.com](mailto:benelux@destaco.com)