

PNEUMATIC AND HYDRAULIC AUTOMATION PRODUCTS

Space-Saving
Engineered Solutions



NASON
NEW THINKING

TABLE OF CONTENTS

7

L SERIES Pneumatic Cylinders



7	Features	28	32mm	Bore	
9	How to Order	32	40mm	Bore	
10	Engineering Data	36	50mm	Bore	
11	Stock Strokes	40	63mm	Bore	
12	12mm	Bore	44	76mm	Bore
16	20mm	Bore	48	101mm	Bore
20	25mm	Bore	50	127mm	Bore
24	28.5mm	Bore	52	152mm	Bore

54

TS SERIES Pneumatic Cylinders



54	Features	60	32mm	Bore	
56	How to Order	61	40mm	Bore	
57	Engineering Data	62	50mm	Bore	
58	20mm	Bore	63	63mm	Bore
59	25mm	Bore	64	76mm	Bore

65

PS SERIES Pneumatic Cylinders



65	Features	71	32mm	Bore	
67	How to Order	72	40mm	Bore	
68	Engineering Data	73	50mm	Bore	
69	20mm	Bore	74	63mm	Bore
70	25mm	Bore	75	76mm	Bore

76

BS SERIES Pneumatic Cylinders



76	Features	82	32mm	Bore	
78	How to Order	83	40mm	Bore	
79	Engineering Data	84	50mm	Bore	
80	20mm	Bore	85	63mm	Bore
81	25mm	Bore	86	76mm	Bore

87

ACCESSORIES



88	Solid State Limit Sensors	94	Pivot Mountings
89	Sensor Low Profile*	95	Hollow Rod
90	Sensor Receptacles	96	Rod End Options
91	Alignment Couplers	97	Urethane Shock Pads
92	Flange Mountings		

98

LC SERIES Non-rotating Load Carrying Cylinders



98	Features	104	28.5mm	Bore	
99	How to Order	105	32mm	Bore	
100	Engineering Data	106	40mm	Bore	
101	12mm	Bore	107	50mm	Bore
102	20mm	Bore	108	63mm	Bore
103	25mm	Bore			

* Product(s) no longer offered by Nason.

109

HB SERIES Pneumatic Block Slide Cylinders

109	Features	113	12mm	Bore
110	How to Order	114	25mm	Bore
111	Engineering Data	115	40mm	Bore
		116	50mm	Bore

117

SC SERIES Stopper Cylinders



117	Features	126	32mm	Bore
118	How to Order	129	40mm	Bore
119	Engineering Data	132	50mm	Bore
120	20mm	135		Rod End Styles
123	25mm	136		Flange Mounts

137

L 15 SERIES Hydraulic Cylinders



137	Features	144	32mm	Bore
138	How to Order	146	40mm	Bore
139	Engineering Data	148	50mm	Bore
140	20mm			Bore
142	25mm			Bore

150

L 20 SERIES Hydraulic Cylinders



150	Features	156	50mm	Bore
151	How to Order	157	63mm	Bore
152	Engineering Data	158	76mm	Bore
153	25mm	159	101mm	Bore
154	32mm	160		Rod End Options
155	40mm	161		Rod Extensions

162

L 30 SERIES Hydraulic Cylinders



162	Features	168	50mm	Bore
163	How to Order	169	63mm	Bore
164	Engineering Data	170	76mm	Bore
165	25mm	171		Rod End Options
166	32mm	172		Rod Extensions
167	40mm			

173

CUSTOM Cylinders



173	Features			
174	Specialty Slides			
174	Special Materials & Coatings			
175	Custom Projects			

NEW THINKING

FOR BETTER SOLUTIONS

For more than seven decades, Nason has provided pneumatic and hydraulic pressure devices to the industrial, military, and mobile hydraulics fields. Over a decade ago, Nason took the knowledge gained from designing and manufacturing custom devices for harsh environments, limited space requirements, and quality, long life products and applied it to our newest product offerings, Pneumatic and Hydraulic Automation products. We knew manufacturing these products would take the same commitments to quality that make our Pressure, Vacuum, and Temperature devices the standard bearers in the industry: quality people, quality materials, and quality designs.

Privately owned and operated, Nason is located on 40 acres in Upstate South Carolina. Nason's 70,000-square-foot manufacturing facility features state-of-the-art CNC manufacturing equipment, as well as a fully staffed manual machinery department which allows Nason to react quickly to customer requirements. Nason's cylinder line is designed around 15 custom extrusions, with over 10,000 feet kept in raw stock to ensure quick reaction to custom design and delivery requests. All cataloged product is kept in stock, in component form, for quick assembly and delivery.





Nason's Engineering Department is staffed with over 75 years of experience in the pneumatic and hydraulic fields. Utilizing the latest 3D CAD software, Nason is fully staffed to meet your most demanding design requirements. 3D models as well as 2D prints of all Nason product lines are available for download from our website. Custom designs can be modeled and delivered quickly for insertion into your assembly models.

Contact Nason for your next automation need. Let us show you why we are the space-saving engineered solutions leader.



NASON

www.mfcp.com

NASON CYLINDERS AT A GLANCE

Compact design—more power in a smaller package

Customized to your specifications

Low breakaway and running friction

100% precision-machined design

Field rebuildable

SMALLER for greater savings

Nason cylinders are small for more effective use of space, but their compact package delivers the same power as larger competitive products. That means you can downsize without compromising power capacity.

STRONGER for longer life

Our cylinders provide significantly more cycles of productive service. We use aluminum or stainless steel bar stock, and we hone the bore until it has a mirror finish. This assures longer seal and cylinder life and better performance.

SMARTER for more flexibility

Unlike some manufacturers who buy extruded stock with pre-drilled holes, we custom drill our cylinders. That way we can accommodate your design specifications for drilling patterns, hole/contour geometry, ports, and mountings. Plus, smarter means being flexible; small or large quantities, any specification, prototype availability, and custom products and service.

We believe there is a smarter way to assure quality as well: all Nason cylinders are made in America in our own manufacturing plant. None of our products or components are produced offshore.

L SERIES

PNEUMATIC CYLINDERS

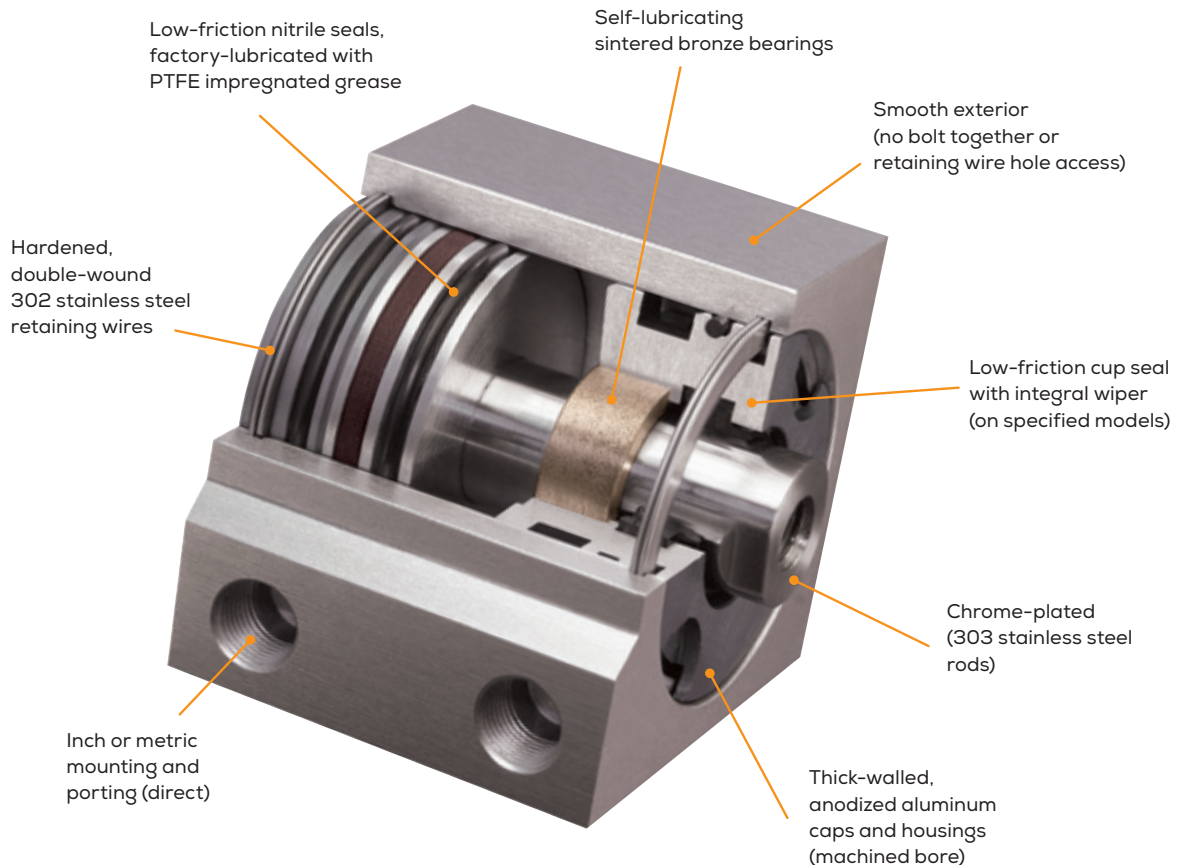

Low Breakaway and Running Friction / Long Life

Designed for low startup and running friction, the L series contains low-friction nitrile seals and is lubricated at the factory with PTFE impregnated grease. Precision-machined components and self-lubricating bearings ensure long life and continued low friction operation.

Compact Size / Clean Design

Nason L series cylinders were designed with today's automation equipment in mind. They offer more power in a smaller package than comparable pancake or compact type cylinders. The smooth exterior of the cylinder body (no bolt together or retaining wire hole access) means no dirt or grease traps.

Rugged Construction

The L series incorporates thick-walled, anodized aluminum housings and caps. Rods are chrome-plated 303 stainless steel riding in self-lubricating bronze bearings, and hardened 302 stainless steel retaining wires are used for assembly.

Rebuildable

All L series cylinders are field rebuildable.

Versatile Design

The L series cylinders are metric in design (bore and rod sizes). They are offered in inch or metric mounting and porting. Due to their 100% machined design, they are easily customized by Nason.

Individual Features

Model LS

- Most compact of 3 models

Double Acting, Single Rod

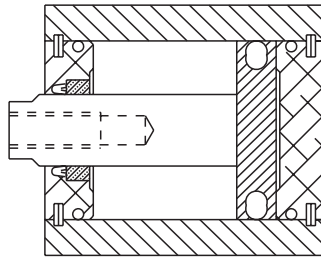

Type "D" - Double Acting, Double Rod

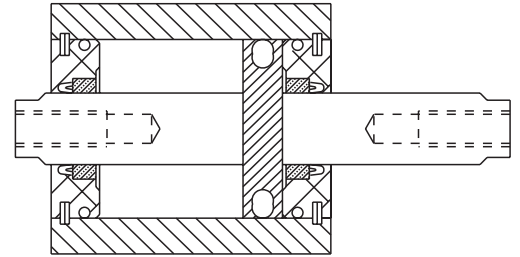

Type "R" - Single Acting, Spring Extend

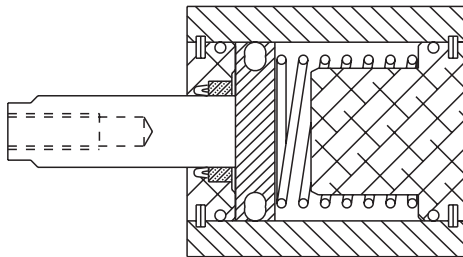

Type "S" - Single Acting, Spring Retract

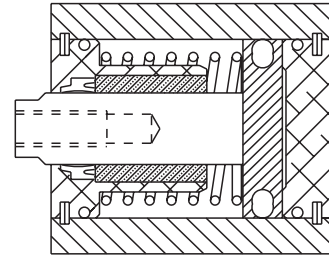

Model LE

- Extended internal rod bearing for additional load support
- Integral seal and rod wiper

Double Acting, Single Rod

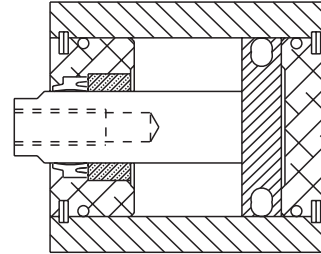

Model LH

- Extended internal rod bearing for additional load support
- Integral seal and rod wiper
- Wear band added to piston for additional load support

Double Acting, Single Rod

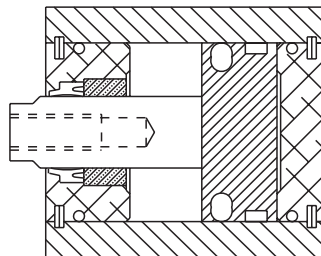

Type "D" - Double Acting, Double Rod

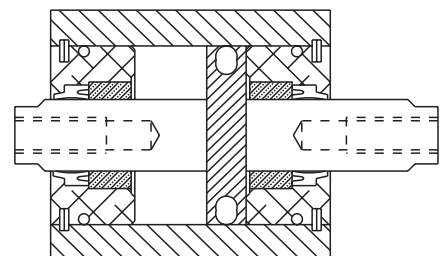

Example: Heavy Duty, 32mm Bore, 50mm stroke, Double Acting Single Rod, Tapped Mounting Both Ends, Nonmagnetic Piston, Inch threads, 17mm Total Rod Extension, Rod Stud

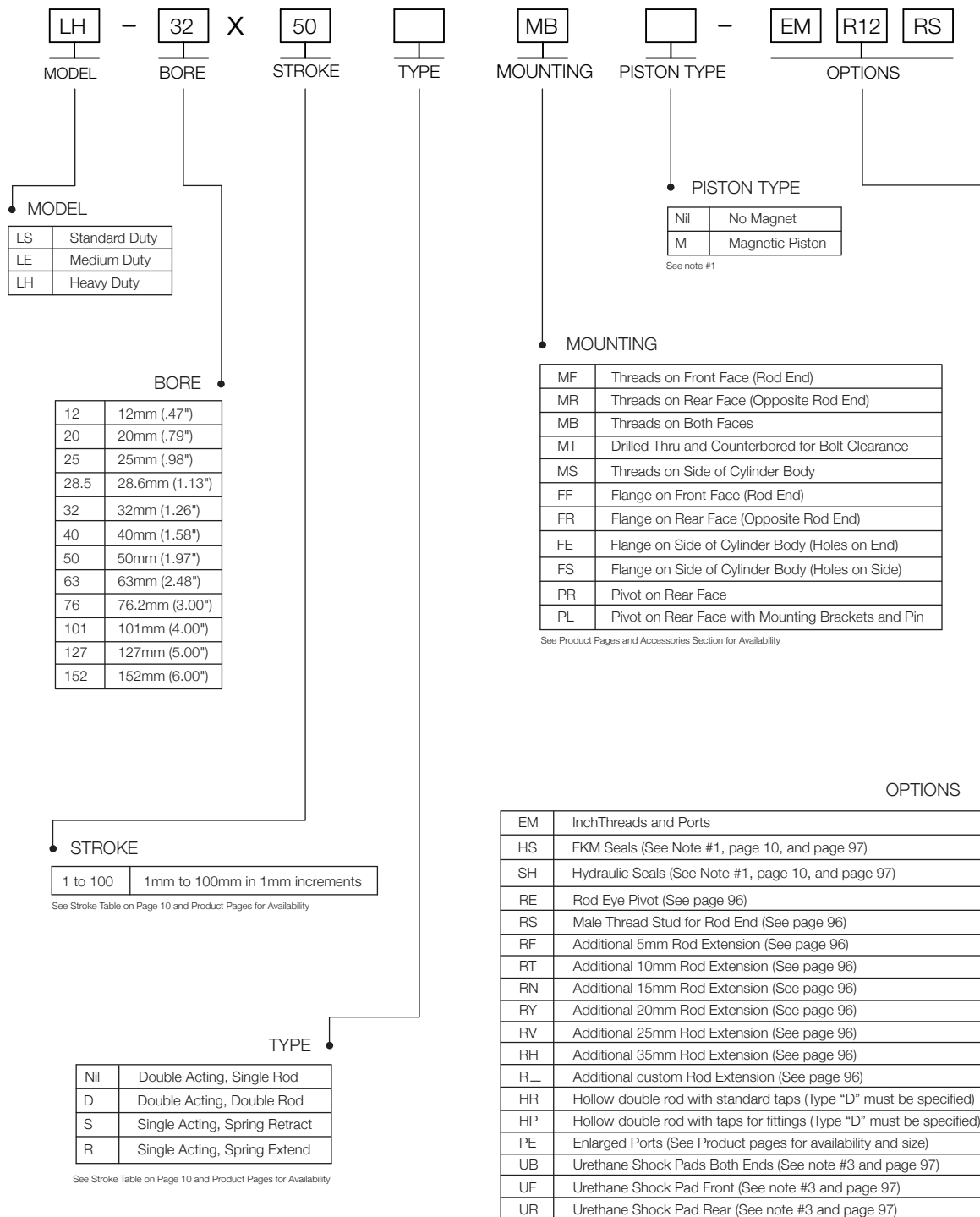

Note 1 - Magnetic Piston "M" limits temperature range to -10°C to 82°C (14°F to 180°F). This temperature rating overrides ALL OTHER TEMPERATURE ratings (Standard Seals, HS Seals, etc.). Magnetic Piston limits Pressure rating 250 PSI (1.7 MPa)

Note 2 - "R_" Enter desired additional Custom Length Rod extension in mm after "R". Example LE-32X40MSM-EMR20.4 would have a TOTAL ROD EXTENSION of 25.4mm (20.4mm+Standard 5mm extension)

Note 3 - "UB", "UF", "UR" Urethane Shock Pads limit temperature range to -10°C to 82°C (14°F to 180°F). This temperature rating overrides ALL OTHER TEMPERATURE ratings (Standard Seals, HS Seals, etc.). Pads are mechanically retained at the Cap faces. "UB" OPTION CHANGES STROKE TOLERANCE TO +/-2mm. "UF" and "UR" OPTION CHANGES STROKE TOLERANCE TO +/-1mm.

Piston Areas and Pressure Ratings

Bore	Piston Area Extend	Piston Area Retract	Maximum Pressure Ratings		
			Standard Pneumatic	Hydraulic (SH Option)	Magnetic (SH Option)
12	1,13 cm ² (.18 in ²)	0,85 cm ² (.14 in ²)	1.0 MPa (150 PSI)	NA	NA
20	3,14 cm ² (.48in ²)	2,64 cm ² (.40in ²)	1.7 MPa (250 PSI)	3.45 MPa (500 PSI)	1.7 MPa (250 PSI)
25	4,91 cm ² (.76 in ²)	4,12 cm ² (.64 in ²)	1.7 MPa (250 PSI)	3.45 MPa (500 PSI)	1.7 MPa (250 PSI)
28.5	6,41 cm ² (1.0 in ²)	5,28 cm ² (.82 in ²)	1.7 MPa (250 PSI)	3.45 MPa (500 PSI)	1.7 MPa (250 PSI)
32	8,04 cm ² (1.25 in ²)	6,91 cm ² (1.07 in ²)	1.7 MPa (250 PSI)	3.45 MPa (500 PSI)	1.7 MPa (250 PSI)
40	12,56 cm ² (1.95 in ²)	10,55 cm ² (1.64 in ²)	1.7 MPa (250 PSI)	3.45 MPa (500 PSI)	1.7 MPa (250 PSI)
50	19,63 cm ² (3.04 in ²)	17,62 cm ² (2.73 in ²)	1.7 MPa (250 PSI)	3.45 MPa (500 PSI)	1.7 MPa (250 PSI)
63	31,17 cm ² (4.83 in ²)	28,03 cm ² (4.34 in ²)	1.7 MPa (250 PSI)	3.45 MPa (500 PSI)	1.7 MPa (250 PSI)
76	45,6 cm ² (7.07 in ²)	42,46 cm ² (6.59 in ²)	1.7 MPa (250 PSI)	3.45 MPa (500 PSI)	1.7 MPa (250 PSI)
101	81,07 cm ² (12.57 in ²)	77,93 cm ² (12.09 in ²)	1.4 MPa (200 PSI)	NA	NA
127	126,7 cm ² (19.6 in ²)	123,5 cm ² (19.1 in ²)	1.4 MPa (200 PSI)	NA	NA
152	181, 46 cm ² (28.2 in ²)	176,55 cm ² (27.45 in ²)	1.4 MPa (200 PSI)	NA	NA

Spring Forces for Type "S" and "R"

Bore	Stroke	Fully Compressed	Spring Rate
12	1mm - 25mm	2.72 kg (6 lbs)	.064 kg/mm (3.6 lbs/in)
20	1mm - 25mm	4.08 kg (9 lbs)	.098 kg/mm (5.5 lbs/in)
20	26mm - 50mm	4.40 kg (9.7 lbs)	.073 kg/mm (4.1 lbs/in)
25	1mm - 25mm	3.04 kg (6.7 lbs)	.063 kg/mm (3.5 lbs/in)
25	26mm - 50mm	3.13 kg (6.9 lbs)	.039 kg/mm (2.2 lbs/in)
28.5	1mm - 25mm	5.94 kg (13.1 lbs)	.134 kg/mm (7.53 lbs/in)
28.5	26mm - 50mm	6.07 kg (13.4 lbs)	.072 kg/mm (4.13 lbs/in)
32	1mm - 25mm	5.67 kg (12.5 lbs)	.134 kg/mm (7.53 lbs/in)
32	26mm - 50mm	6.03 kg (13.3 lbs)	.072 kg/mm (4.13 lbs/in)
40	1mm - 25mm	8.62 kg (19 lbs)	.198 kg/mm (11.1 lbs/in)
40	26mm - 50mm	9.03 kg (19.9 lbs)	.107 kg/mm (6.0 lbs/in)
50	1mm - 25mm	8.62 kg (19 lbs)	.198 kg/mm (11.1 lbs/in)
50	26mm - 50mm	9.03 kg (19.9 lbs)	.107 kg/mm (6.0 lbs/in)

Specifications

Media (Standard and HS Seals)	Air - Clean, Dry Or Lubricated
Media (SH Seals)	Standard Mineral Hydraulic Fluid
Pre-Lubricated at Factory	Non-soap elastomer/PTFE thickener
Temp. Range (Std.)	-10°C to 93°C (14°F to 200°F)
Temp. Range (Mag. Piston)	-10°C to 82°C (14°F to 180°F) See Note 2 & 3
Temp. Range (UB Option)	-10°C to 82°C (14°F to 180°F) See Note 2 & 3
Temp. Range (HS Option)	-10°C to 150°C (14°F to 302°F) See Note 2 & 3
Stroke Tolerance (Std)	+1mm/-0 (+0.04"/-0)
Stroke Tolerance (UB)	+/-2mm (+/- .08")
Stroke Tolerance (UF)	+/-1mm (+/- .04")
Stroke Tolerance (UR)	+/-1mm (+/- .04")

Note 1 - Longer strokes and other increments available upon request

Note 2 - Magnetic Piston "M" limits temperature range to -10°C to 82°C (14°F to 180°F). This temperature rating overrides ALL OTHER TEMPERATURE ratings (Standard Seals, HS Seals, etc.). Magnetic Piston and Sensor mounting tracks are provided on Front Stroke Cylinder only.

Note 3 - "UB", "UF", "UR" Urethane Shock Pads limit temperature range to -10°C to 82°C (14°F to 180°F). This temperature rating overrides ALL OTHER TEMPERATURE ratings (Standard Seals, HS Seals, etc.). Pads are mechanically retained at the Cap faces. "UB" OPTION CHANGES STROKE TOLERANCE TO +/-2mm.

"UF" and "UR" OPTION CHANGES STROKE TOLERANCE TO +/-1mm. "UB", "UF", and "UR" Not available with "SH" Seal Option.

Note 4 - While all Models are offered in all strokes, it is recommended that strokes over 50mm use LE or LH Models for added bearing support.

Available Strokes

Model LS - 10mm through 100mm in 1mm increments
Model LS with Magnetic Piston - 5mm through 100mm in 1mm increments
Models LE & LH (Standard and Magnetic Piston) - 5mm through 100mm in 1mm increments
Model LS, LE & LH 28.5mm Bore (Standard and Magnetic Piston) - 6.35mm through 101.6mm in 6.35mm increments
Model LS, Type S and R (Standard and Magnetic Piston) 12mm Bore - 5mm through 25mm in 1mm increments
Model LS, Type S and R (Standard and Magnetic Piston) 20mm Bore Thru 50mm Bore - 5mm through 50mm in 1mm increments
Model LS, Type S and R 28.5mm Bore (Standard and Magnetic Piston) - 6.35mm through 50.8mm in 6.35mm increments

See note #1 and #4

Stock Strokes for Quick Delivery

Ship in 2-3 Days
 Models LS, LE, and LH
 Standard and Magnetic Pistons
 Mounting Styles MF, MR, MB, MT, and MS
 Metric and Inch Threads
 Single Rod End Type Cylinders

Bore Sizes - 20mm, 25mm, 32mm			
1-10 pieces	Stock Strokes (Ship 2-3 days)		
Model	LS	LE	LH
Standard Piston	20mm	15mm	10mm
Magnetic Piston	15mm	10mm	5mm
Standard Piston	30mm	25mm	20mm
Magnetic Piston	25mm	20mm	15mm
Standard Piston	45mm	40mm	35mm
Magnetic Piston	40mm	35mm	30mm
Standard Piston	55mm	50mm	45mm
Magnetic Piston	50mm	45mm	40mm
Standard Piston	70mm	65mm	60mm
Magnetic Piston	65mm	60mm	55mm
Standard Piston	80mm	75mm	70mm
Magnetic Piston	75mm	70mm	65mm

Bore Sizes - 40mm, 50mm			
1-10 pieces	Stock Strokes (Ship 2-3 days)		
Model	LS	LE	LH
Standard Piston	25mm	15mm	10mm
Magnetic Piston	20mm	10mm	5mm
Standard Piston	35mm	25mm	20mm
Magnetic Piston	30mm	20mm	15mm
Standard Piston	50mm	40mm	35mm
Magnetic Piston	45mm	35mm	30mm
Standard Piston	60mm	50mm	45mm
Magnetic Piston	55mm	45mm	40mm
Standard Piston	75mm	65mm	60mm
Magnetic Piston	70mm	60mm	55mm
Standard Piston	85mm	75mm	70mm
Magnetic Piston	80mm	70mm	65mm

Strokes

Bore Size	Standard (Non-Magnetic)		5mm	10mm	15mm	20mm	25mm	30mm	35mm	40mm	45mm	50mm	55mm	60mm	65mm	70mm	75mm	80mm	85mm	
20mm	Model	LS				*		*			*		*			*		*		
		LE			*		*			*		*		*		*		*		
		LH		*		*			*		*		*		*		*		*	
25mm	Magnetic Piston		5mm	10mm	15mm	20mm	25mm	30mm	35mm	40mm	45mm	50mm	55mm	60mm	65mm	70mm	75mm	80mm	85mm	
		Model	LS			*		*			*		*		*		*		*	
			LE		*		*			*		*		*		*		*		*
LH	*			*			*		*		*		*		*		*			

Strokes

Bore Size	Standard (Non-Magnetic)		5mm	10mm	15mm	20mm	25mm	30mm	35mm	40mm	45mm	50mm	55mm	60mm	65mm	70mm	75mm	80mm	85mm	
40mm	Model	LS					*		*			*		*		*		*		
		LE			*		*			*		*		*		*		*		
		LH		*		*			*		*		*		*		*		*	
50mm	Magnetic Piston		5mm	10mm	15mm	20mm	25mm	30mm	35mm	40mm	45mm	50mm	55mm	60mm	65mm	70mm	75mm	80mm	85mm	
		Model	LS			*		*			*		*		*		*		*	
			LE		*		*			*		*		*		*		*		*
LH	*			*			*		*		*		*		*		*			

Non Magnetic Front Mount Cylinder "MF"

MODEL	TYPE	STANDARD STROKES	"A"	PISTON AREA
LS	-	10mm - 50mm	16,0(0.63")	PUSH 1,13 cm ² (0.18 in ²)
LE	-	5mm - 50mm	21,0(0.83")	
LH	-	5mm - 50mm	26,0(1.03")	PULL 0,85 cm ² (0.14 in ²)
LS	S,R	5mm - 25mm	31,0(1.22")	

	Standard Threads	"EM" Option
"B"	M5X0,8	#10-32
"C"	M4X0,7	#8-32
"D"	M4X0,7	#8-32

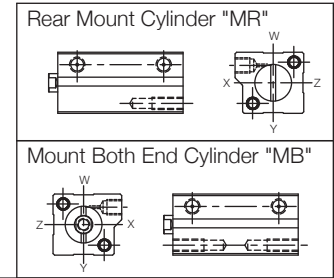
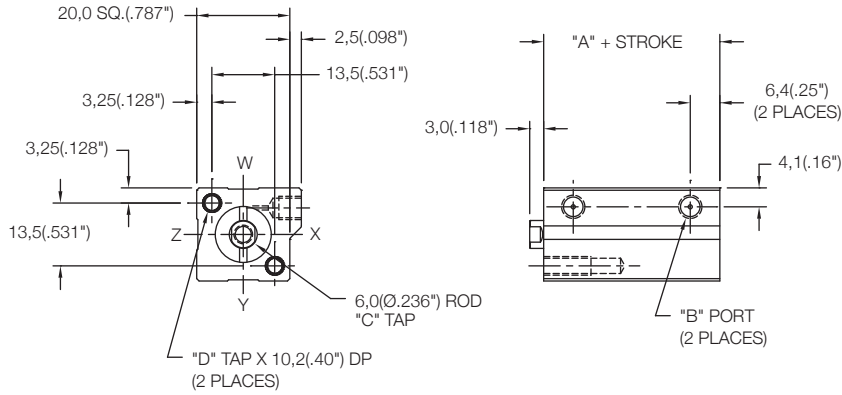

Non Magnetic Thru Mount Cylinder "MT"

MODEL	TYPE	STANDARD STROKES	"A"	PISTON AREA
LS	-	10mm - 20mm	16,0(0.63")	PUSH 1,13 cm ² (0.18 in ²)
LE	-	5mm - 15mm	21,0(0.83")	
LH	-	5mm - 10mm	26,0(1.03")	PULL 0,85 cm ² (0.14 in ²)
LS	S,R	5mm	31,0(1.22")	

	Standard Threads	"EM" Option
"B"	M5X0,8	#10-32
"C"	M4X0,7	#8-32

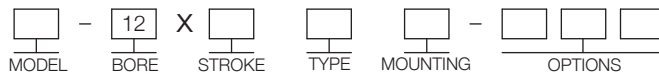
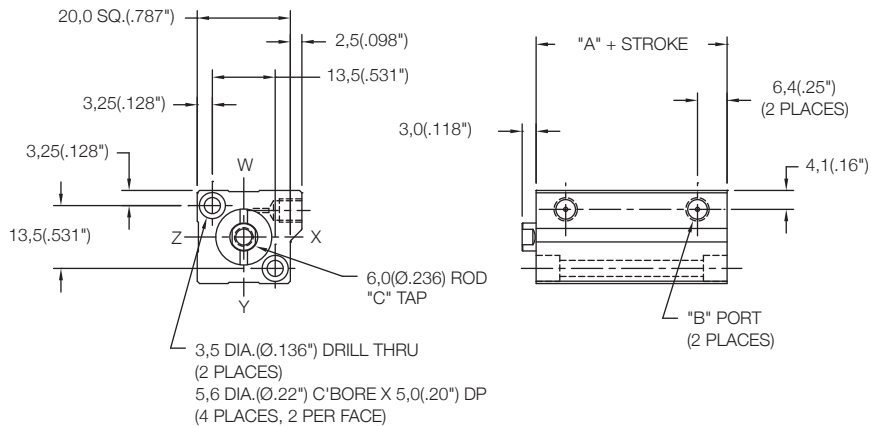

MODEL
LS
LE
LH

5mm - 50mm STROKE
(SEE STROKE RANGE)

BLANK - NO CODE, DOUBLE
ACTING, SINGLE ROD

S - SINGLE ACTING, SPRING RETRACT
R - SINGLE ACTING, SPRING EXTEND

MT - THRU MOUNT
MF - FRONT MOUNT
MR - REAR MOUNT
MB - BOTH END MOUNTS
FF - FRONT FLANGE
FR - REAR FLANGE
(FOR FLANGES SEE PAGE 92)
PR - REAR PIVOT
(FOR PIVOT SEE PAGE 94)

EM - INCH THREADS & PORT OPTIONS

HS - HIGH TEMPERATURE SEALS OPTION:
AVAILABLE ON LE AND LH MODELS ONLY
(SEE PAGE 97)

RE - ROD EYE
(SEE PAGE 96)

RS - MALE STUD FOR ROD END
(SEE PAGE 96)

RF, RH, RN, RT, RV, RY - ROD EXTENSIONS
(SEE PAGE 96)

Magnetic Front Mount Cylinder "MF"

MODEL	TYPE	STANDARD STROKES	"A"	PISTON AREA
LS	-	10mm - 50mm	26,0(1.03")	PUSH 1,13 cm ² (0.18 in ²)
LE	-	5mm - 50mm	31,0(1.23")	
LH	-	5mm - 50mm	36,0(1.42")	PULL 0,85 cm ² (0.14 in ²)
LS	S,R	5mm - 25mm	41,0(1.62")	

	Standard Threads	"EM" Option
"B"	M5X0,8	#10-32
"C"	M4X0,7	#8-32
"D"	M4X0,7	#8-32

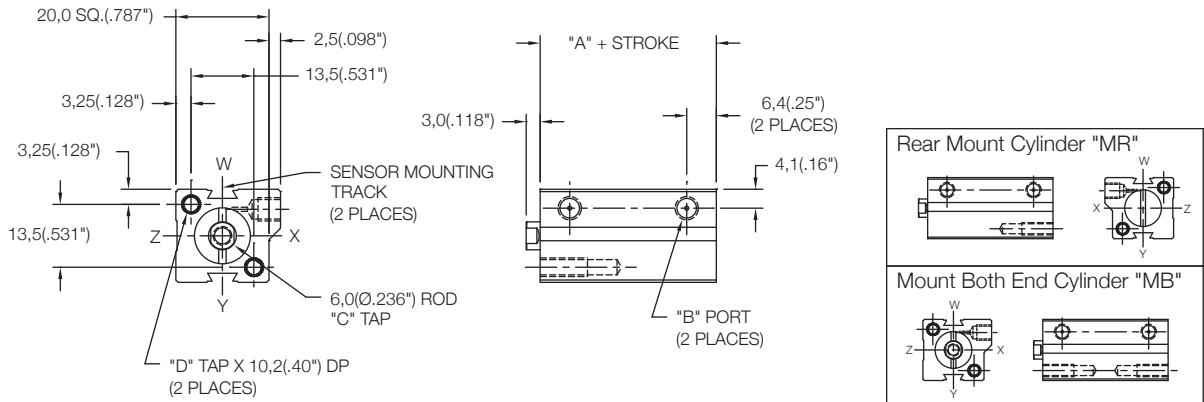

Magnetic Thru Mount Cylinder "MT"

MODEL	TYPE	STANDARD STROKES	"A"	PISTON AREA
LS	-	10mm	26,0(1.03")	PUSH 1,13 cm ² (0.18 in ²)
LE	-	5mm	31,0(1.23")	

	Standard Threads	"EM" Option
"B"	M5X0,8	#10-32
"C"	M4X0,7	#8-32

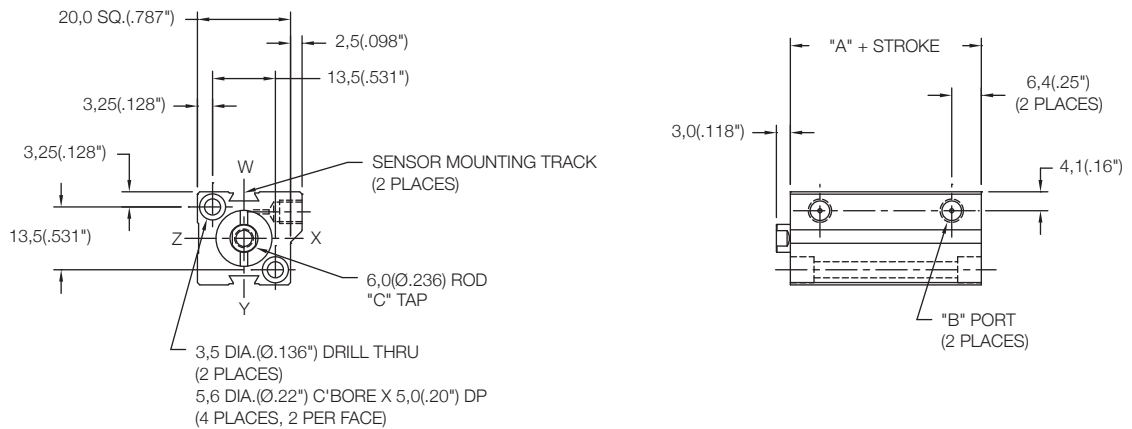

MODEL - 12 X STROKE TYPE MOUNTING MAGNETIC - OPTIONS

MODEL: LS, LE, LH
 BORE: 12mm
 STROKE: 5mm - 50mm (SEE STROKE RANGE)
 TYPE: BLANK - NO CODE, DOUBLE ACTING, SINGLE ROD; S - SINGLE ACTING, SPRING RETRACT; R - SINGLE ACTING, SPRING EXTEND
 MOUNTING: MT - THRU MOUNT; MF - FRONT MOUNT; MR - REAR MOUNT; MB - BOTH END MOUNTS; FF - FRONT FLANGE; FR - REAR FLANGE (FOR FLANGES SEE PAGE 92); PR - REAR PIVOT (FOR PIVOT SEE PAGE 94)
 MAGNETIC: M - MAGNETIC
 OPTIONS: EM - INCH THREADS & PORT OPTIONS; HS - HIGH TEMPERATURE SEALS OPTION: AVAILABLE ON LE AND LH MODELS ONLY (SEE PAGE 97); RE - ROD EYE (SEE PAGE 96); RS - MALE STUD FOR ROD END (SEE PAGE 96); RF, RH, RN, RT, RV, RY - ROD EXTENSIONS (SEE PAGE 96)

SENSORS SOLD SEPARATELY
 SKS, SKP, SCS, SCP - SOLID STATE
 LIMIT SENSORS (SEE PAGE 88)

Magnetic Side Mount Cylinder "MS"

MODEL	TYPE	STANDARD STROKES	"A"	PISTON AREA
LS	-	10mm	26,0(1.03")	PUSH 1,13 cm ² (0.18 in ²)
LE	-	5mm	31,0(1.23")	PULL 0,85 cm ² (0.14 in ²)

	Standard Threads	"EM" Option
"B"	M5X0,8	#10-32
"C"	M4X0,7	#8-32
"D"	M3X0,5	#4-40

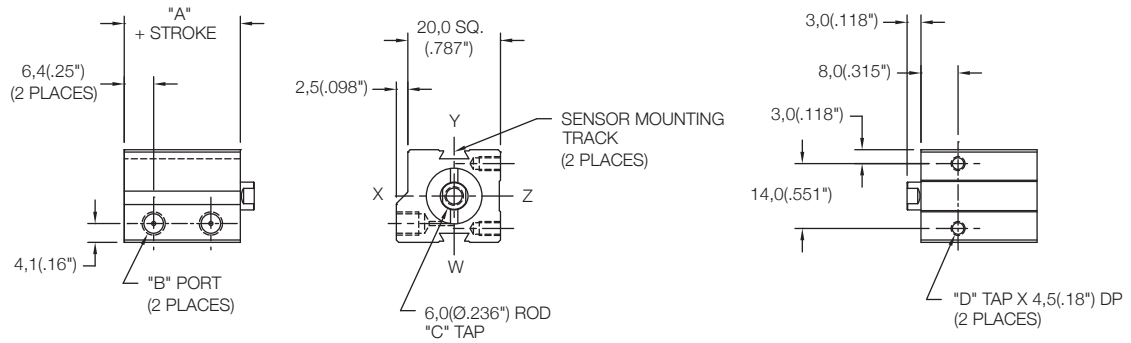

Magnetic Side Mount Cylinder "MS"

MODEL	TYPE	STANDARD STROKES	"A"	PISTON AREA
LS	-	15mm - 50mm	26,0(1.03")	PUSH 1,13 cm ² (0.18 in ²)
LE	-	10mm - 50mm	31,0(1.23")	
LH	-	5mm - 50mm	36,0(1.42")	PULL 0,85 cm ² (0.14 in ²)
LS	S,R	5mm - 25mm	41,0(1.62")	

	Standard Threads	"EM" Option
"B"	M5X0,8	#10-32
"C"	M4X0,7	#8-32
"D"	M3X0,5	#4-40

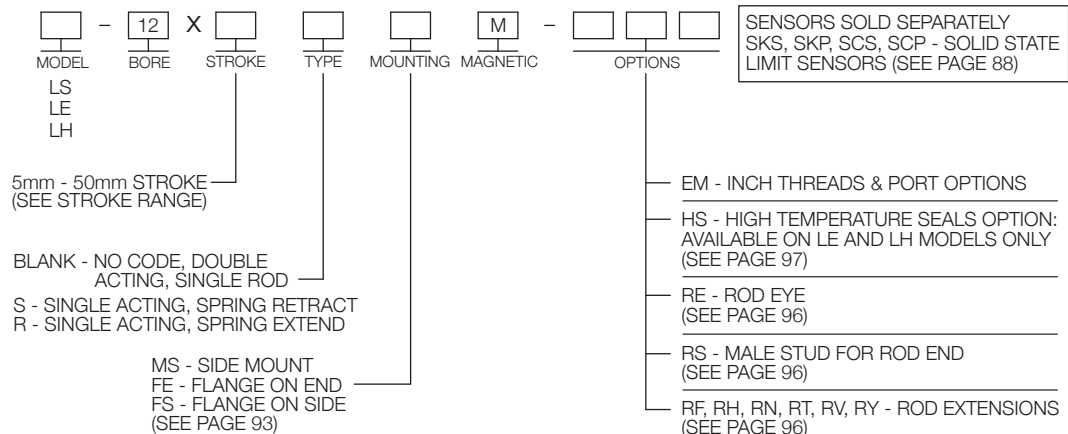
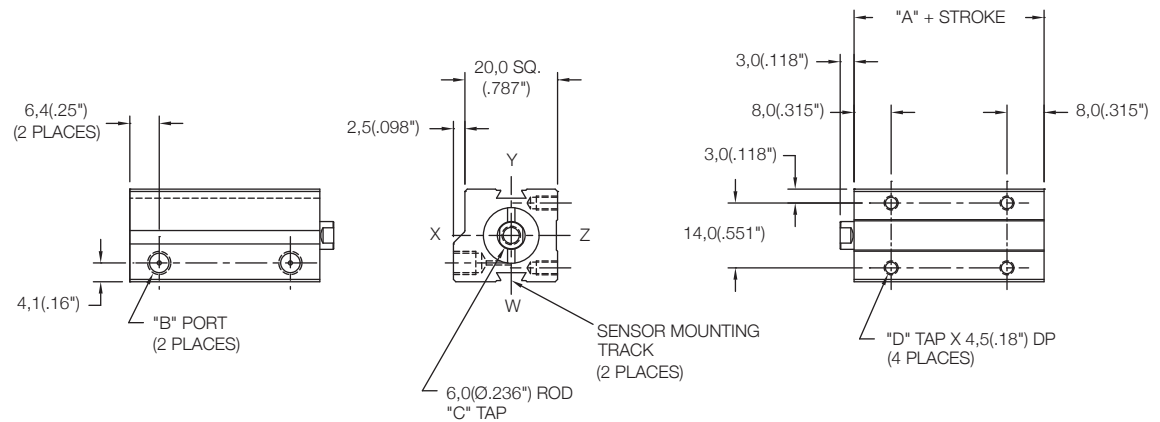

Non Magnetic Side Mount Cylinder "MS"

MODEL	TYPE	STANDARD STROKES	"A"	PISTON AREA
LS	-	10mm - 20mm	16,0(0.63")	PUSH 1,13 cm ² (0.18 in ²)
LE	-	5mm - 15mm	21,0(0.83")	
LH	-	5mm - 10mm	26,0(1.03")	
LS	S,R	5mm	31,0(1.22")	PULL 0,85 cm ² (0.14 in ²)

	Standard Threads	"EM" Option
"B"	M5X0,8	#10-32
"C"	M4X0,7	#8-32
"D"	M3X0,5	#4-40

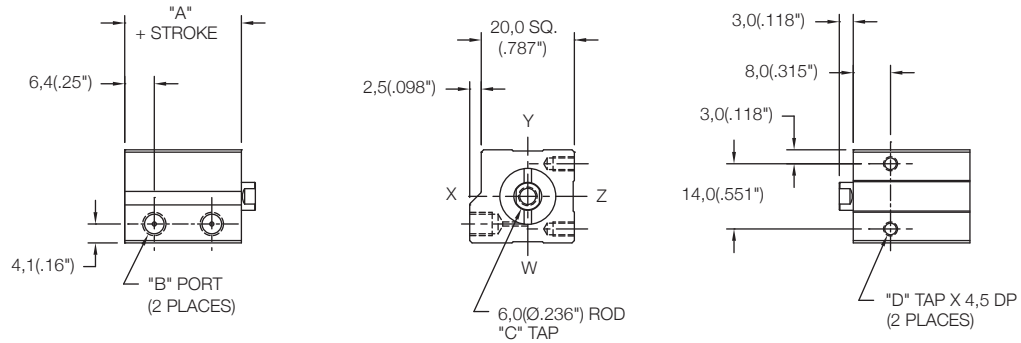

Non Magnetic Side Mount Cylinder "MS"

MODEL	TYPE	STANDARD STROKES	"A"	PISTON AREA
LS	-	25mm - 50mm	16,0(0.63")	PUSH 1,13 cm ² (0.18 in ²)
LE	-	20mm - 50mm	21,0(0.83")	
LH	-	15mm - 50mm	26,0(1.03")	
LS	S,R	10mm - 25mm	31,0(1.22")	PULL 0,85 cm ² (0.14 in ²)

	Standard Threads	"EM" Option
"B"	M5X0,8	#10-32
"C"	M4X0,7	#8-32
"D"	M3X0,5	#4-40

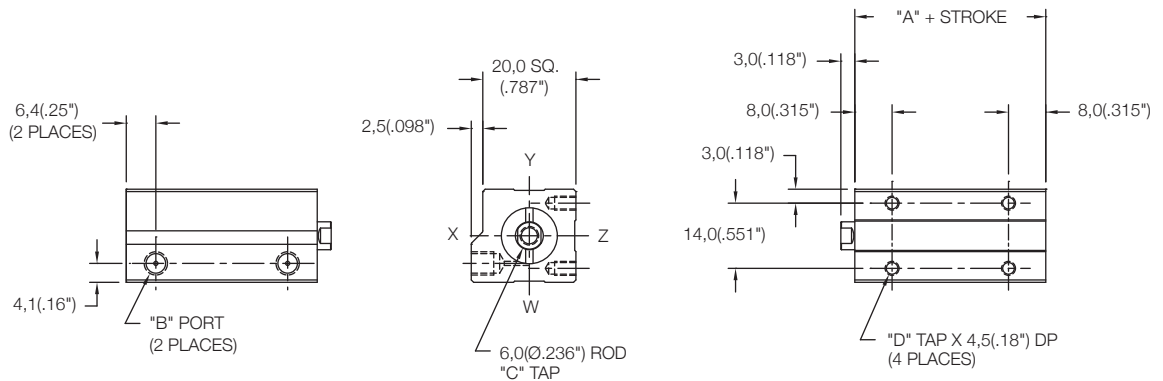

- MODEL
LS
LE
LH
- 5mm - 50mm STROKE
(SEE STROKE RANGE)
- BLANK - NO CODE, DOUBLE ACTING, SINGLE ROD
- S - SINGLE ACTING, SPRING RETRACT
- R - SINGLE ACTING, SPRING EXTEND
- MS - SIDE MOUNT
- FE - FLANGE ON END
- FS - FLANGE ON SIDE
(SEE PAGE 93)

- EM - INCH THREADS & PORT OPTIONS
- HS - HIGH TEMPERATURE SEALS OPTION:
AVAILABLE ON LE AND LH MODELS ONLY
(SEE PAGE 97)
- RE - ROD EYE
(SEE PAGE 96)
- RS - MALE STUD FOR ROD END
(SEE PAGE 96)
- RF, RH, RN, RT, RV, RY - ROD EXTENSIONS
(SEE PAGE 96)

Magnetic Front Mount Cylinder "MF"

MODEL	TYPE	STANDARD STROKES	"A"	PISTON AREA
LS	_D	5mm - 100mm	23,5(0.93")	PUSH 3,14 cm ² (0.48 in ²)
LE	_	5mm - 100mm	28,5(1.12")	
LH	_D	5mm - 100mm	33,5(1.32")	
LS	S,R	5mm - 50mm	38,5(1.52")	PULL 2,64 cm ² (0.40 in ²)

	Standard Threads	"EM" Option
"B"	M5X0,8	#10-32
"C"	M5X0,8	#10-32
"D"	M5X0,8	#10-32

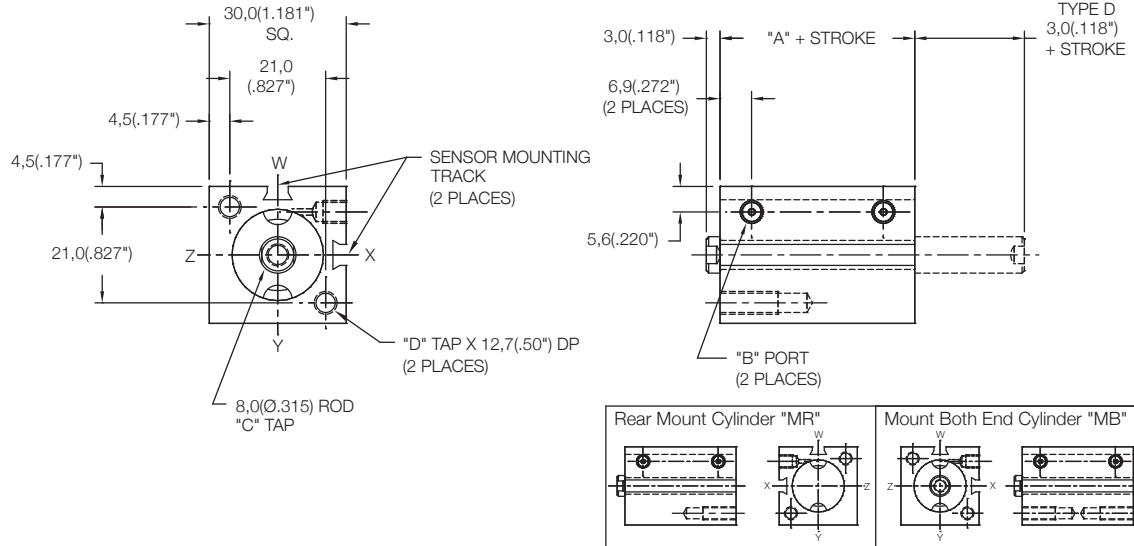

Magnetic Thru Mount Cylinder "MT"

MODEL	TYPE	STANDARD STROKES	"A"	PISTON AREA
LS	_D	5mm - 20mm	23,5(0.93")	PUSH 3,14 cm ² (0.48 in ²)
LE	_	5mm - 15mm	28,5(1.12")	
LH	_D	5mm - 10mm	33,5(1.32")	
LS	S,R	5mm	38,5(1.52")	PULL 2,64 cm ² (0.40 in ²)

	Standard Threads	"EM" Option
"B"	M5X0,8	#10-32
"C"	M5X0,8	#10-32

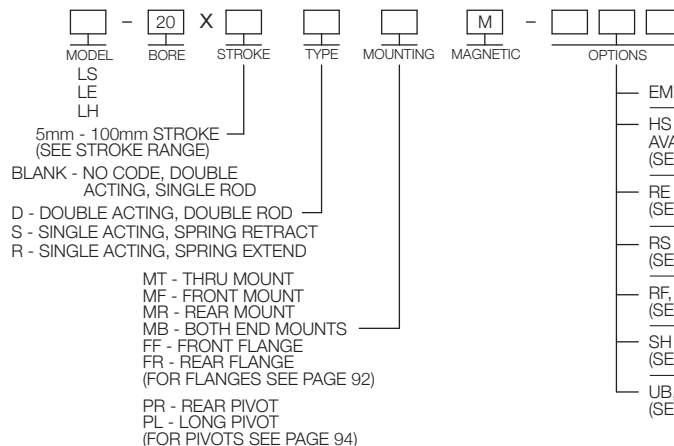
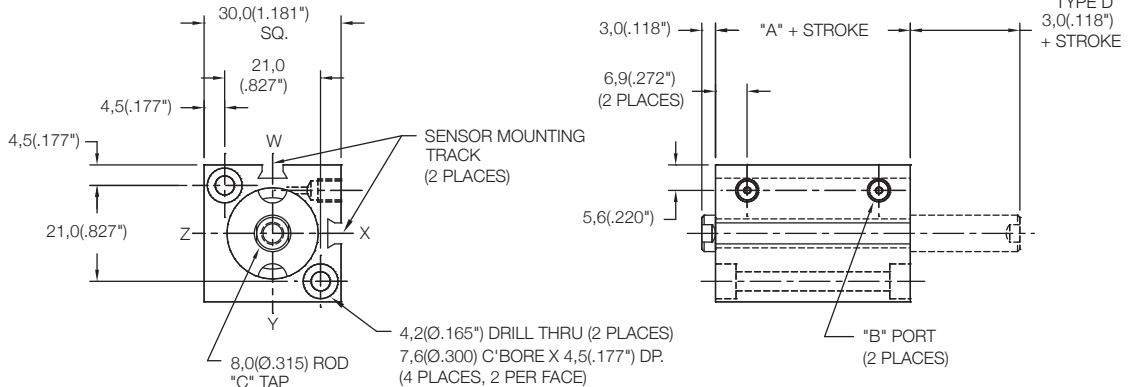

SENSORS SOLD SEPARATELY
SKS, SKP, SCS, SCP - SOLID STATE
LIMIT SENSORS (SEE PAGE 88)

Magnetic Side Mount Cylinder "MS"

MODEL	TYPE	STANDARD STROKES	"A"	PISTON AREA
LS	_,D	5mm - 15mm	23,5(0.93")	PUSH 3,14 cm ² (0.48 in ²)
LE	_	5mm - 10mm	28,5(1.12")	
LH	_,D	5mm	33,5(1.32")	PULL 2,64 cm ² (0.40 in ²)

	Standard Threads	"EM" Option
"B"	M5X0,8	#10-32
"C"	M5X0,8	#10-32
"D"	M4X0,7	#8-32

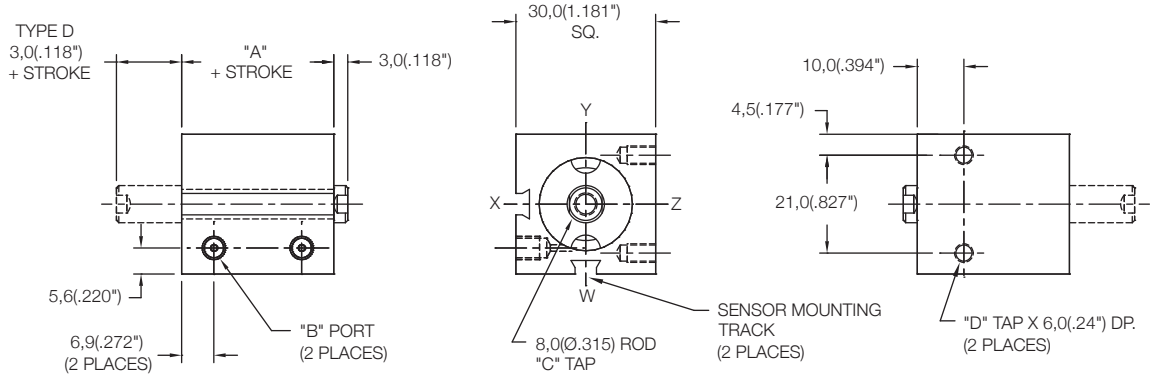

Magnetic Side Mount Cylinder "MS"

MODEL	TYPE	STANDARD STROKES	"A"	PISTON AREA
LS	_,D	20mm - 100mm	23,5(0.93")	PUSH 3,14 cm ² (0.48 in ²)
LE	_	15mm - 100mm	28,5(1.12")	
LH	_,D	10mm - 100mm	33,5(1.32")	PULL 2,64 cm ² (0.40 in ²)
LS	S,R	5mm - 50mm	38,5(1.52")	

	Standard Threads	"EM" Option
"B"	M5X0,8	#10-32
"C"	M5X0,8	#10-32
"D"	M4X0,7	#8-32

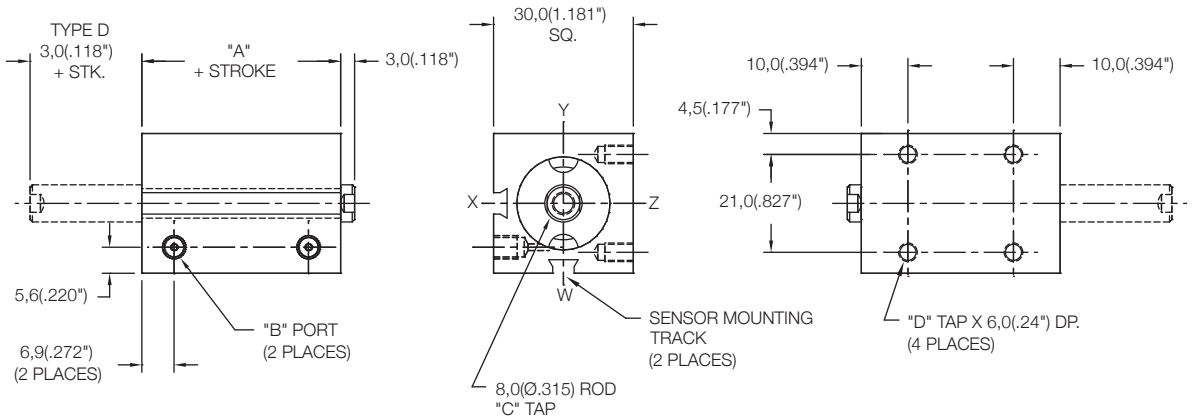

<table border="0"> <tr> <td>MODEL</td> <td>-</td> <td>20</td> <td>X</td> <td>STROKE</td> <td>TYPE</td> <td>MOUNTING</td> <td>MAGNETIC</td> <td>-</td> <td>OPTIONS</td> </tr> <tr> <td>LS</td> <td></td> <td></td> <td></td> <td></td> <td></td> <td></td> <td>M</td> <td></td> <td></td> </tr> <tr> <td>LE</td> <td></td> <td></td> <td></td> <td></td> <td></td> <td></td> <td></td> <td></td> <td></td> </tr> <tr> <td>LH</td> <td></td> <td></td> <td></td> <td></td> <td></td> <td></td> <td></td> <td></td> <td></td> </tr> </table> <p>5mm - 100mm STROKE (SEE STROKE RANGE)</p> <p>BLANK - NO CODE, DOUBLE ACTING, SINGLE ROD</p> <p>D - DOUBLE ACTING, DOUBLE ROD</p> <p>S - SINGLE ACTING, SPRING RETRACT</p> <p>R - SINGLE ACTING, SPRING EXTEND</p> <p>MS - SIDE MOUNT</p> <p>FE - FLANGE ON END</p> <p>FS - FLANGE ON SIDE (SEE PAGE 93)</p>	MODEL	-	20	X	STROKE	TYPE	MOUNTING	MAGNETIC	-	OPTIONS	LS							M			LE										LH										<p>SENSORS SOLD SEPARATELY SKS, SKP, SCS, SCP - SOLID STATE LIMIT SENSORS (SEE PAGE 88)</p> <p>EM - INCH THREADS & PORT OPTIONS</p> <p>HS - HIGH TEMPERATURE SEALS OPTION: AVAILABLE ON LE AND LH MODELS ONLY (SEE PAGE 97)</p> <p>RE - ROD EYE (SEE PAGE 96)</p> <p>RS - MALE STUD FOR ROD END (SEE PAGE 96)</p> <p>RF, RH, RN, RT, RV, RY - ROD EXTENSIONS (SEE PAGE 96)</p> <p>SH - HYDRAULIC OPTION (35 BAR 500 PSI) (SEE PAGE 97)</p> <p>UB, UF, UR - URETHANE SHOCK PAD OPTION (SEE PAGE 97)</p>
MODEL	-	20	X	STROKE	TYPE	MOUNTING	MAGNETIC	-	OPTIONS																																
LS							M																																		
LE																																									
LH																																									

**Non Magnetic
Side Mount Cylinder "MS"**

MODEL	TYPE	STANDARD STROKES	"A"	PISTON AREA
LS	...D	10mm - 20mm	18,5(0.73")	PUSH 3,14 cm ² (0.48 in ²)
LE	-	5mm - 15mm	23,5(0.93")	
LH	...D	5mm - 10mm	28,5(1.12")	PULL 2,64 cm ² (0.40 in ²)
LS	S,R	5mm	33,5(1.32")	

	Standard Threads	"EM" Option
"B"	M5X0,8	#10-32
"C"	M5X0,8	#10-32
"D"	M4X0,7	#8-32

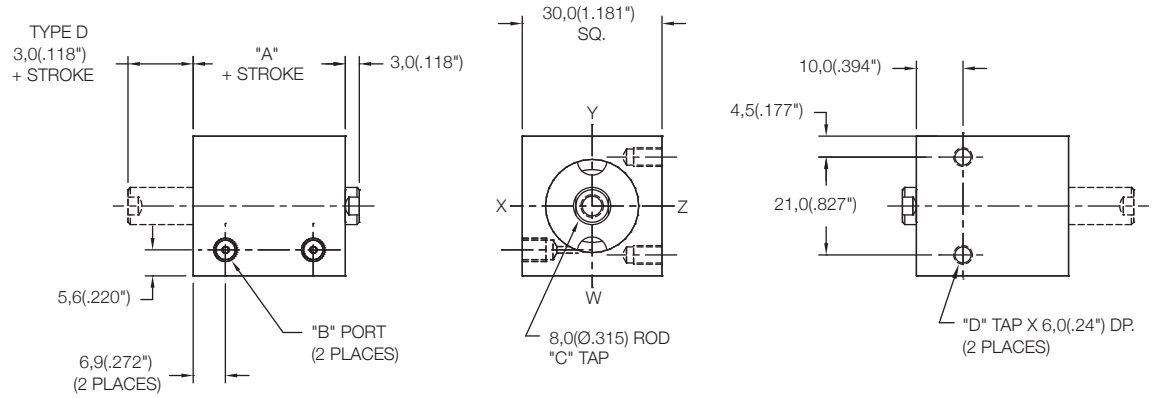

**Non Magnetic
Side Mount Cylinder "MS"**

MODEL	TYPE	STANDARD STROKES	"A"	PISTON AREA
LS	...D	25mm - 100mm	18,5(0.73")	PUSH 3,14 cm ² (0.48 in ²)
LE	-	20mm - 100mm	23,5(0.93")	
LH	...D	15mm - 100mm	28,5(1.12")	PULL 2,64 cm ² (0.40 in ²)
LS	S,R	10mm - 50mm	33,5(1.32")	

	Standard Threads	"EM" Option
"B"	M5X0,8	#10-32
"C"	M5X0,8	#10-32
"D"	M4X0,7	#8-32

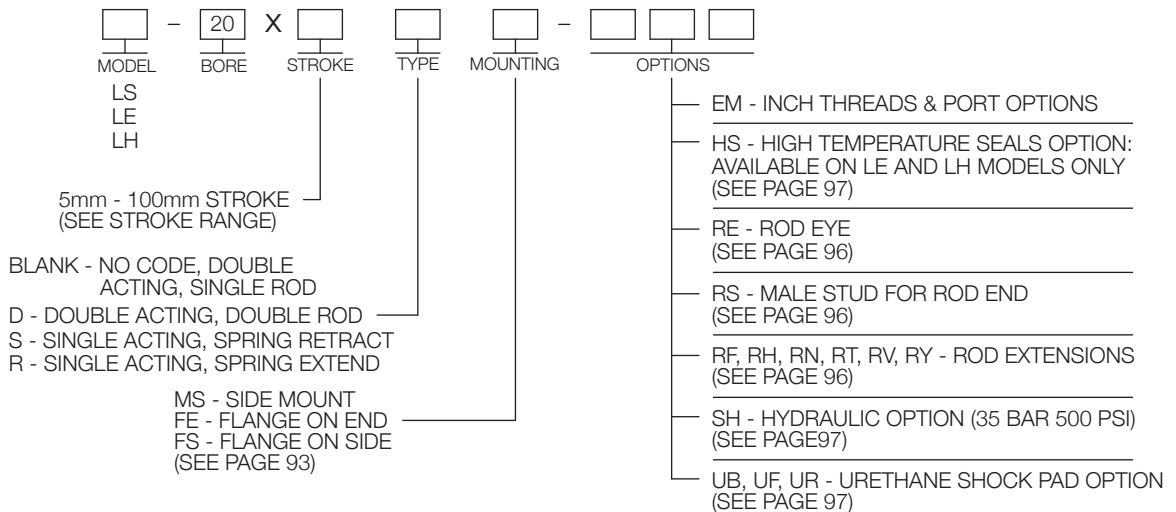
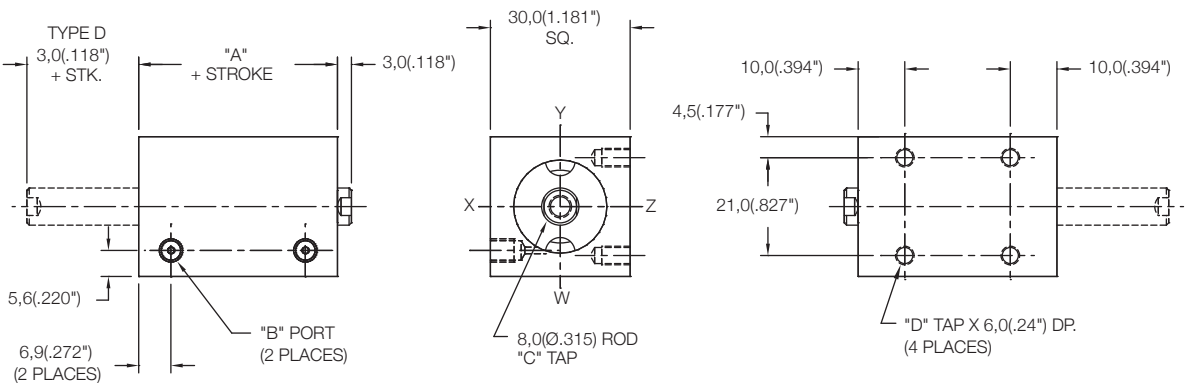

Non Magnetic Front Mount Cylinder "MF"

MODEL	TYPE	STANDARD STROKES	"A"	PISTON AREA
LS	_,D	10mm - 100mm	19,0(0.75")	PUSH 4,91 cm ² (0.76 in ²)
LE	_	5mm - 100mm	24,0(0.95")	
LH	_,D	5mm - 100mm	29,0(1.14")	PULL 4,12 cm ² (0.64 in ²)
LS	S,R	5mm - 25mm	34,0(1.34")	
LS	S,R	26mm - 50mm	39,0(1.54")	

	Standard Threads	"EM" Option
"B"	M5X0,8	#10-32
"C"	M5X0,8	#10-32
"D"	M5X0,8	#10-32

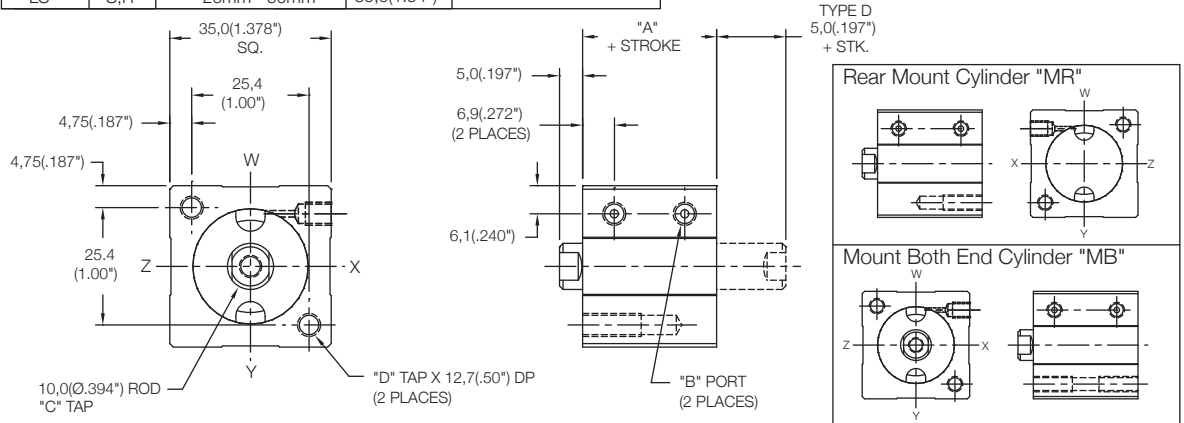

Non Magnetic Thru Mount Cylinder "MT"

MODEL	TYPE	STANDARD STROKES	"A"	PISTON AREA
LS	_,D	10mm - 25mm	19,0(0.75")	PUSH 4,91 cm ² (0.76 in ²)
LE	_	5mm - 20mm	24,0(0.95")	
LH	_,D	5mm - 15mm	29,0(1.14")	PULL 4,12 cm ² (0.64 in ²)
LS	S,R	5mm - 10mm	34,0(1.34")	

	Standard Threads	"EM" Option
"B"	M5X0,8	#10-32
"C"	M5X0,8	#10-32

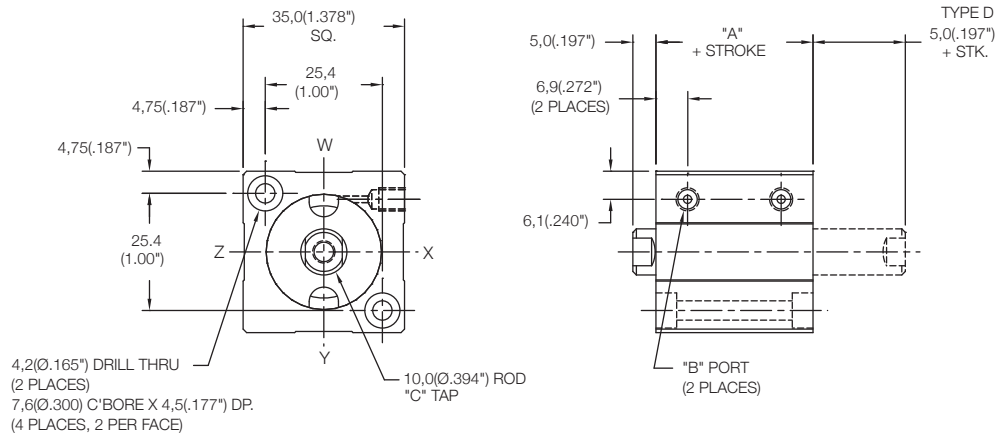

 - 25 X -

MODEL BORE STROKE TYPE MOUNTING OPTIONS

LS
LE
LH

5mm - 100mm STROKE
(SEE STROKE RANGE)

BLANK - NO CODE, DOUBLE ACTING, SINGLE ROD
 D - DOUBLE ACTING, DOUBLE ROD
 S - SINGLE ACTING, SPRING RETRACT
 R - SINGLE ACTING, SPRING EXTEND

MT - THRU MOUNT
 MF - FRONT MOUNT
 MR - REAR MOUNT
 MB - BOTH END MOUNTS
 FF - FRONT FLANGE
 FR - REAR FLANGE
 (FOR FLANGES SEE PAGE 92)

PR - REAR PIVOT
 PL - LONG PIVOT
 (FOR PIVOTS SEE PAGE 94)

EM - INCH THREADS & PORT OPTIONS
 HS - HIGH TEMPERATURE SEALS OPTION:
 AVAILABLE ON LE AND LH MODELS ONLY
 (SEE PAGE 97)
 PE - PORT ENLARGEMENT (AVAILABLE W/
 "EM" OPTION ONLY = 1/8-27 NPT PORTS)
 RE - ROD EYE
 (SEE PAGE 96)
 RS - MALE STUD FOR ROD END
 (SEE PAGE 96)
 RF, RH, RN, RT, RV, RY - ROD EXTENSIONS
 (SEE PAGE 96)
 SH - HYDRAULIC OPTION (35 BAR 500 PSI)
 (SEE PAGE 97)
 UB, UF, UR - URETHANE SHOCK PAD OPTION
 (SEE PAGE 97)

Magnetic Front Mount Cylinder "MF"

MODEL	TYPE	STANDARD STROKES	"A"	PISTON AREA
LS	_D	5mm - 50mm	24,0(0.95")	PUSH 4,91 cm ² (0.76 in ²)
LE	-	5mm - 100mm	29,0(1.14")	
LH	_D	5mm - 100mm	34,0(1.34")	PULL 4,12 cm ² (0.64 in ²)
LS	S,R	5mm - 25mm	39,0(1.54")	
LS	S,R	26mm - 50mm	44,0(1.74")	

	Standard Threads	"EM" Option
"B"	M5X0,8	#10-32
"C"	M5X0,8	#10-32
"D"	M5X0,8	#10-32

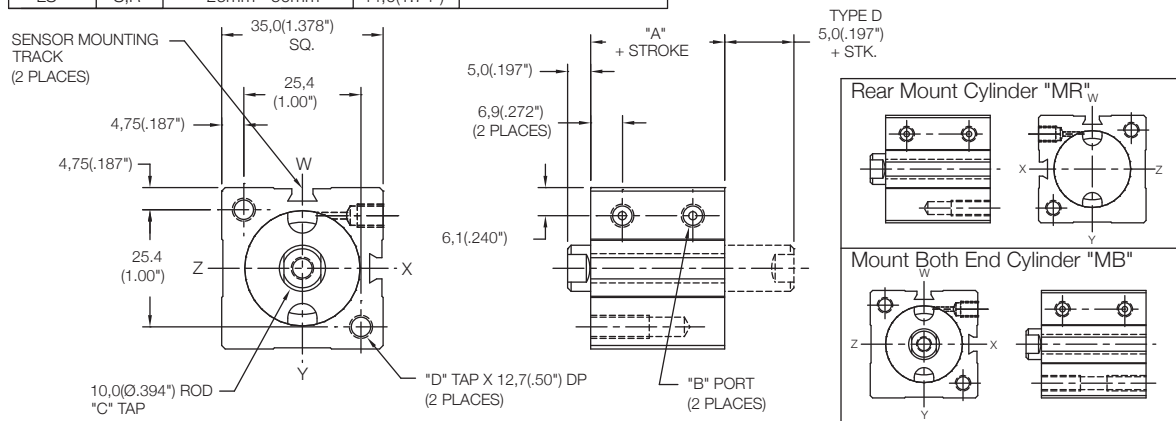

Magnetic Thru Mount Cylinder "MT"

MODEL	TYPE	STANDARD STROKES	"A"	PISTON AREA
LS	_D	5mm - 20mm	24,0(0.95")	PUSH 4,91 cm ² (0.76 in ²)
LE	-	5mm - 15mm	29,0(1.14")	
LH	_D	5mm - 10mm	34,0(1.34")	PULL 4,12 cm ² (0.64 in ²)
LS	S,R	5mm	39,0(1.54")	

	Standard Threads	"EM" Option
"B"	M5X0,8	#10-32
"C"	M5X0,8	#10-32

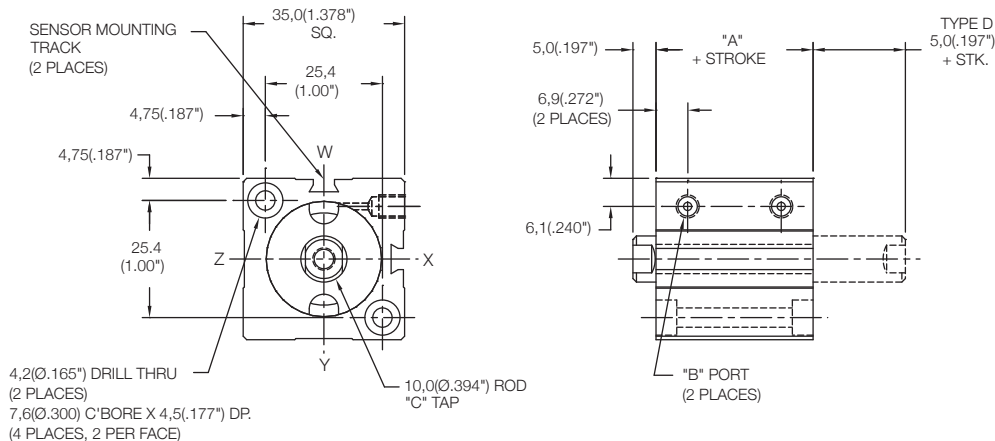

 - 25 X M -

MODEL BORE STROKE TYPE MOUNTING MAGNETIC OPTIONS

LS
LE
LH

5mm - 100mm STROKE
(SEE STROKE RANGE)

BLANK - NO CODE, DOUBLE ACTING, SINGLE ROD
 D - DOUBLE ACTING, DOUBLE ROD
 S - SINGLE ACTING, SPRING RETRACT
 R - SINGLE ACTING, SPRING EXTEND

MT - THRU MOUNT
 MF - FRONT MOUNT
 MR - REAR MOUNT
 MB - BOTH END MOUNTS
 FF - FRONT FLANGE
 FR - REAR FLANGE
 (FOR FLANGES SEE PAGE 92)

PR - REAR PIVOT
 PL - LONG PIVOT
 (FOR PIVOTS SEE PAGE 94)

SENSORS SOLD SEPARATELY
 SKS, SKP, SCS, SCP - SOLID STATE
 LIMIT SENSORS (SEE PAGE 88)

EM - INCH THREADS & PORT OPTIONS
 HS - HIGH TEMPERATURE SEALS OPTION:
 AVAILABLE ON LE AND LH MODELS ONLY
 (SEE PAGE 97)
 PE - PORT ENLARGEMENT (AVAILABLE W/
 "EM" OPTION ONLY = 1/8-27 NPT PORTS)
 RE - ROD EYE
 (SEE PAGE 96)
 RS - MALE STUD FOR ROD END
 (SEE PAGE 96)
 RF, RH, RN, RT, RV, RY - ROD EXTENSIONS
 (SEE PAGE 96)
 SH - HYDRAULIC OPTION (35 BAR 500 PSI)
 (SEE PAGE 97)
 UB, UF, UR - URETHANE SHOCK PAD OPTION
 (SEE PAGE 97)

Magnetic Side Mount Cylinder "MS"

MODEL	TYPE	STANDARD STROKES	"A"	PISTON AREA
LS	...D	5mm - 15mm	24,0(0.95")	PUSH 4,91 cm ² (0.76 in ²)
LE	-	5mm - 10mm	29,0(1.14")	
LH	...D	5mm	34,0(1.34")	PULL 4,12 cm ² (0.64 in ²)

	Standard Threads	"EM" Option
"B"	M5X0,8	#10-32
"C"	M5X0,8	#10-32
"D"	M5X0,8	#10-32

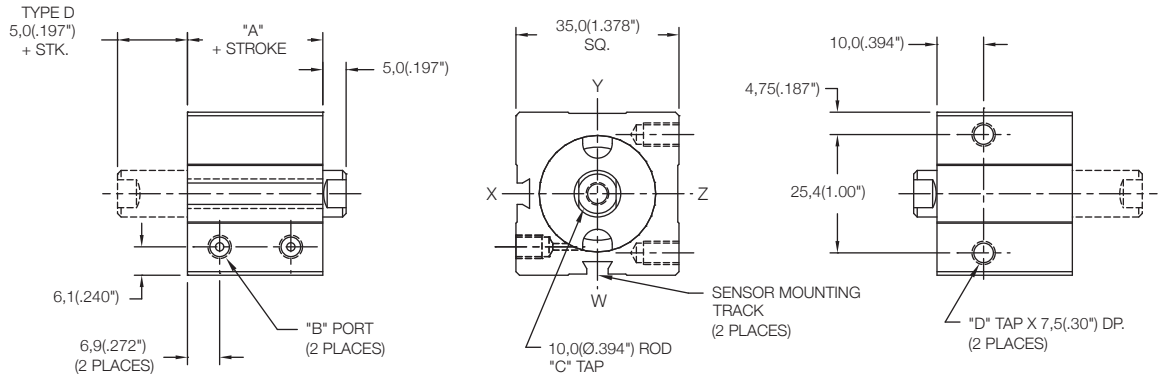

Magnetic Side Mount Cylinder "MS"

MODEL	TYPE	STANDARD STROKES	"A"	PISTON AREA
LS	...D	20mm - 100mm	24,0(0.95")	PUSH 4,91 cm ² (0.76 in ²)
LE	-	15mm - 100mm	29,0(1.14")	
LH	...D	10mm - 100mm	34,0(1.34")	PULL 4,12 cm ² (0.64 in ²)
LS	S,R	5mm - 25mm	39,0(1.54")	
LS	S,R	26mm - 50mm	44,0(1.74")	

	Standard Threads	"EM" Option
"B"	M5X0,8	#10-32
"C"	M5X0,8	#10-32
"D"	M5X0,8	#10-32

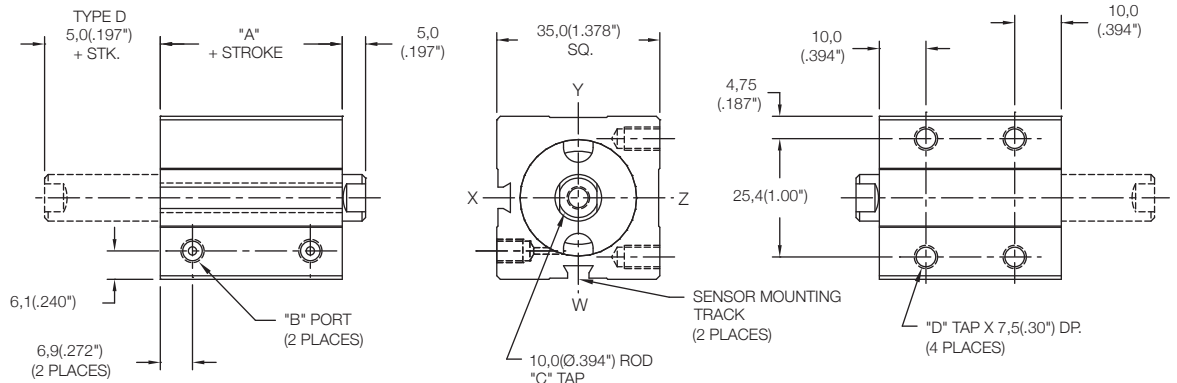

<p>MODEL - 25 X STROKE TYPE MOUNTING MAGNETIC OPTIONS</p> <p>LS LE LH</p> <p>5mm - 100mm STROKE (SEE STROKE RANGE)</p> <p>BLANK - NO CODE, DOUBLE ACTING, SINGLE ROD</p> <p>D - DOUBLE ACTING, DOUBLE ROD S - SINGLE ACTING, SPRING RETRACT R - SINGLE ACTING, SPRING EXTEND</p> <p>MS - SIDE MOUNT FE - FLANGE ON END FS - FLANGE ON SIDE (SEE PAGE 93)</p>	<p>SENSORS SOLD SEPARATELY SKS, SKP, SCS, SCP - SOLID STATE LIMIT SENSORS (SEE PAGE 88)</p> <p>EM - INCH THREADS & PORT OPTIONS</p> <p>HS - HIGH TEMPERATURE SEALS OPTION: AVAILABLE ON LE AND LH MODELS ONLY (SEE PAGE 97)</p> <p>PE - PORT ENLARGEMENT (AVAILABLE W/ "EM" OPTION ONLY = 1/8-27 NPT PORTS)</p> <p>RE - ROD EYE (SEE PAGE 96)</p> <p>RS - MALE STUD FOR ROD END (SEE PAGE 96)</p> <p>RF, RH, RN, RT, RV, RY - ROD EXTENSIONS (SEE PAGE 96)</p> <p>SH - HYDRAULIC OPTION (35 BAR 500 PSI) (SEE PAGE 97)</p> <p>UB, UF, UR - URETHANE SHOCK PAD OPTION (SEE PAGE 97)</p>
--	--

Non Magnetic Side Mount Cylinder "MS"

MODEL	TYPE	STANDARD STROKES	"A"	PISTON AREA
LS	_D	10mm - 20mm	19,0(0.75")	PUSH 4,91 cm ² (0.76 in ²)
LE	-	5mm - 15mm	24,0(0.95")	
LH	_D	5mm - 10mm	29,0(1.14")	PULL 4,12 cm ² (0.64 in ²)
LS	S,R	5mm	34,0(1.34")	

	Standard Threads	"EM" Option
"B"	M5X0,8	#10-32
"C"	M5X0,8	#10-32
"D"	M5X0,8	#10-32

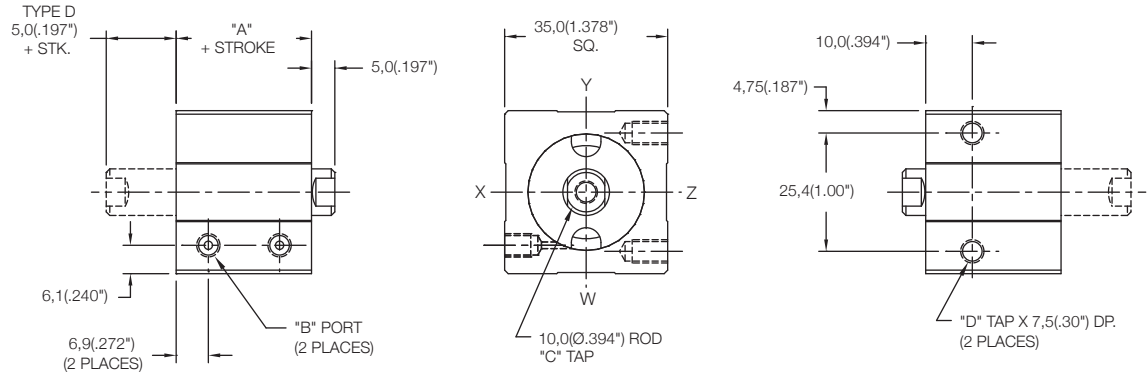

Non Magnetic Side Mount Cylinder "MS"

MODEL	TYPE	STANDARD STROKES	"A"	PISTON AREA
LS	_D	25mm - 100mm	19,0(0.75")	PUSH 4,91 cm ² (0.76 in ²)
LE	-	20mm - 100mm	24,0(0.95")	
LH	_D	15mm - 100mm	29,0(1.14")	PULL 4,12 cm ² (0.64 in ²)
LS	S,R	10mm - 25mm	34,0(1.34")	
LS	S,R	26mm - 50mm	39,0(1.54")	

	Standard Threads	"EM" Option
"B"	M5X0,8	#10-32
"C"	M5X0,8	#10-32
"D"	M5X0,8	#10-32

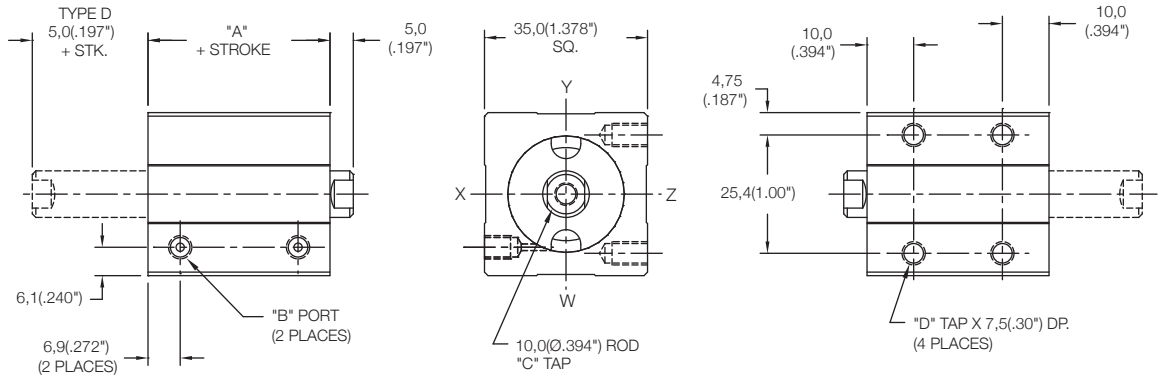

 - 25 X -

MODEL BORE STROKE TYPE MOUNTING OPTIONS

LS
LE
LH

5mm - 100mm STROKE
(SEE STROKE RANGE)

BLANK - NO CODE, DOUBLE ACTING, SINGLE ROD

D - DOUBLE ACTING, DOUBLE ROD
 S - SINGLE ACTING, SPRING RETRACT
 R - SINGLE ACTING, SPRING EXTEND

MS - SIDE MOUNT
 FE - FLANGE ON END
 FS - FLANGE ON SIDE
 (SEE PAGE 93)

EM - INCH THREADS & PORT OPTIONS
 HS - HIGH TEMPERATURE SEALS OPTION:
 AVAILABLE ON LE AND LH MODELS ONLY
 (SEE PAGE 97)
 PE - PORT ENLARGEMENT (AVAILABLE W/
 "EM" OPTION ONLY = 1/8-27 NPT PORTS)
 RE - ROD EYE
 (SEE PAGE 96)
 RS - MALE STUD FOR ROD END
 (SEE PAGE 96)
 RF, RH, RN, RT, RV, RY - ROD EXTENSIONS
 (SEE PAGE 96)
 SH - HYDRAULIC OPTION (35 BAR 500 PSI)
 (SEE PAGE 97)
 UB, UF, UR - URETHANE SHOCK PAD OPTION
 (SEE PAGE 97)

Magnetic Front Mount Cylinder "MF"

MODEL	TYPE	STANDARD STROKES	"A"	PISTON AREA
LS	...D	6,35mm - 101,6mm	25,4(1.00")	PUSH 6,41 cm ² (1.0 in ²)
LE	-	6,35mm - 101,6mm	31,75(1.25")	
LH	...D	6,35mm - 101,6mm	38,1(1.50")	
LS	S,R	6,35mm - 25,4mm	38,1(1.50")	PULL 5,28 cm ² (0.82 in ²)
LS	S,R	31,8mm - 50,8mm	44,45(1.75")	

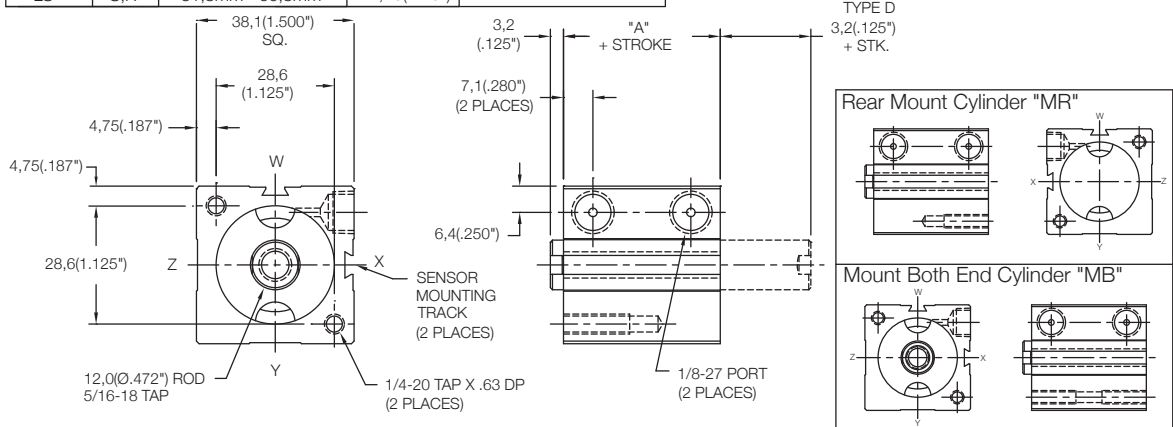

Magnetic Thru Mount Cylinder "MT"

MODEL	TYPE	STANDARD STROKES	"A"	PISTON AREA
LS	...D	6,35mm - 19,05mm	25,4(1.00")	PUSH 6,41 cm ² (1.0 in ²)
LE	-	6,35mm - 12,7mm	31,75(1.25")	
LH	...D	6,35mm	38,1(1.50")	
LS	S,R	6,35mm	38,1(1.50")	PULL 5,28 cm ² (0.82 in ²)

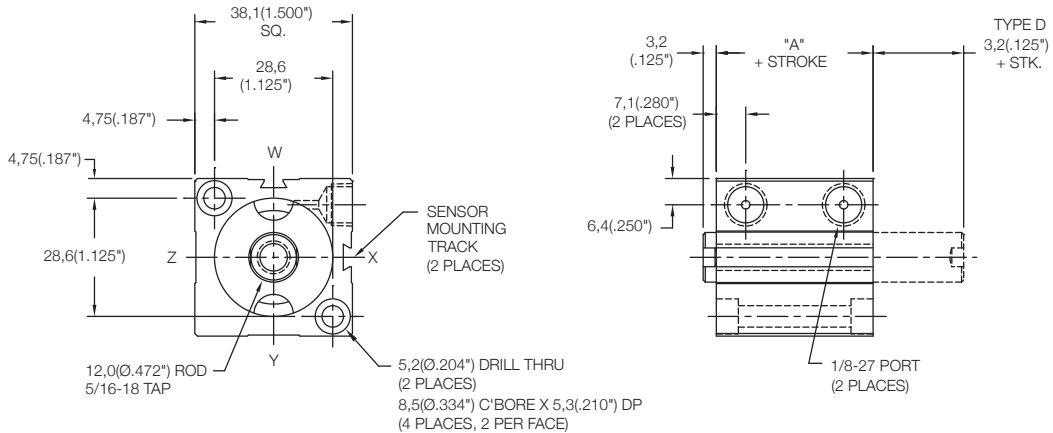

<div style="border: 1px solid black; width: 20px; height: 10px; margin: 0 auto;"></div> MODEL LS LE LH	- 28,5 X <div style="border: 1px solid black; width: 20px; height: 10px; margin: 0 auto;"></div> BORE STROKE	<div style="border: 1px solid black; width: 20px; height: 10px; margin: 0 auto;"></div> TYPE	<div style="border: 1px solid black; width: 20px; height: 10px; margin: 0 auto;"></div> MOUNTING	<div style="border: 1px solid black; width: 20px; height: 10px; margin: 0 auto;"></div> MAGNETIC	<div style="border: 1px solid black; width: 20px; height: 10px; margin: 0 auto;"></div> - <div style="border: 1px solid black; width: 20px; height: 10px; margin: 0 auto;"></div> OPTIONS	SENSORS SOLD SEPARATELY SKS, SKP, SCS, SCP - SOLID STATE LIMIT SENSORS (SEE PAGE 88)
6,35mm - 101,6mm STROKE (SEE STROKE RANGE)		BLANK - NO CODE, DOUBLE ACTING, SINGLE ROD		D - DOUBLE ACTING, DOUBLE ROD S - SINGLE ACTING, SPRING RETRACT R - SINGLE ACTING, SPRING EXTEND		HS - HIGH TEMPERATURE SEALS OPTION: AVAILABLE ON LE AND LH MODELS ONLY (SEE PAGE 97)
MT - THRU MOUNT MF - FRONT MOUNT MR - REAR MOUNT MB - BOTH END MOUNTS		FF - FRONT FLANGE FR - REAR FLANGE (FOR FLANGES SEE PAGE 92)		RE - ROD EYE (SEE PAGE 96)		
PR - REAR PIVOT PL - LONG PIVOT (FOR PIVOTS SEE PAGE 94)		RF, RH, RN, RT, RV, RY - ROD EXTENSIONS (SEE PAGE 96)		SH - HYDRAULIC OPTION (35 BAR 500 PSI) (SEE PAGE 97)		
				UB, UF, UR - URETHANE SHOCK PAD OPTION (SEE PAGE 97)		

Magnetic Side Mount Cylinder "MS"

MODEL	TYPE	STANDARD STROKES	"A"	PISTON AREA
LS	_,D	6,35mm - 12,7mm	25,4(1.00")	PUSH 6,41 cm ² (1.0 in ²)
LE	_	6,35mm	31,75(1.25")	PULL 5,28 cm ² (0.82 in ²)

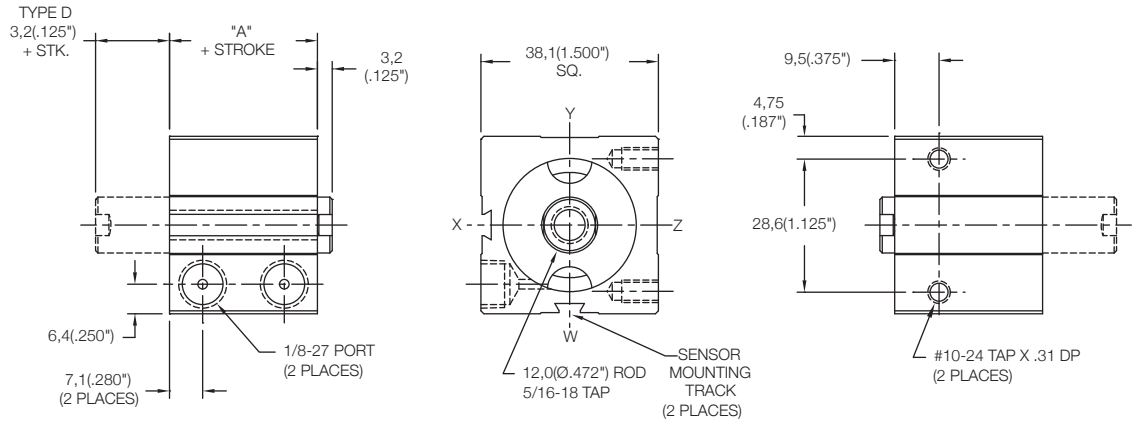

Magnetic Side Mount Cylinder "MS"

MODEL	TYPE	STANDARD STROKES	"A"	PISTON AREA
LS	_,D	19,05mm - 101,6mm	25,4(1.00")	PUSH 6,41 cm ² (1.0 in ²)
LE	_	12,7mm - 101,6mm	31,75(1.25")	PUSH 6,41 cm ² (1.0 in ²)
LH	_,D	6,35mm - 101,6mm	38,1(1.50")	PULL 5,28 cm ² (0.82 in ²)
LS	S,R	6,35mm - 25,4mm	38,1(1.50")	PULL 5,28 cm ² (0.82 in ²)
LS	S,R	31,8mm - 50,8mm	44,45(1.75")	PULL 5,28 cm ² (0.82 in ²)

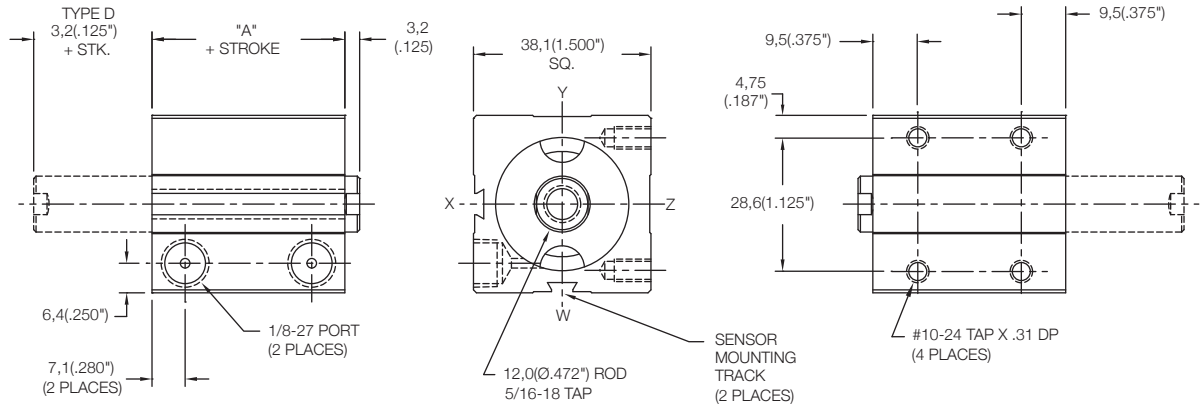

<p>MODEL</p> <p>LS LE LH</p> <p>6.35mm - 101.6mm STROKE (SEE STROKE RANGE)</p> <p>BLANK - NO CODE, DOUBLE ACTING, SINGLE ROD</p> <p>D - DOUBLE ACTING, DOUBLE ROD</p> <p>S - SINGLE ACTING, SPRING RETRACT</p> <p>R - SINGLE ACTING, SPRING EXTEND</p> <p>MS - SIDE MOUNT</p> <p>FE - FLANGE ON END</p> <p>FS - FLANGE ON SIDE (SEE PAGE 93)</p>	<p>28.5</p> <p>X</p> <p>STROKE</p> <p>TYPE</p> <p>MOUNTING</p> <p>MAGNETIC</p> <p>M</p> <p>OPTIONS</p>	<p>SENSORS SOLD SEPARATELY SKS, SKP, SCS, SCP - SOLID STATE LIMIT SENSORS (SEE PAGE 88)</p> <p>HS - HIGH TEMPERATURE SEALS OPTION: AVAILABLE ON LE AND LH MODELS ONLY (SEE PAGE 97)</p> <p>RE - ROD EYE (SEE PAGE 96)</p> <p>RS - MALE STUD FOR ROD END (SEE PAGE 96)</p> <p>RF, RH, RN, RT, RV, RY - ROD EXTENSIONS (SEE PAGE 96)</p> <p>SH - HYDRAULIC OPTION (35 BAR 500 PSI) (SEE PAGE 97)</p> <p>UB, UF, UR - URETHANE SHOCK PAD OPTION (SEE PAGE 97)</p>
--	--	--

Non Magnetic Side Mount Cylinder "MS"

MODEL	TYPE	STANDARD STROKES	"A"	PISTON AREA
LS	..D	6,35mm - 19,05mm	19,05(0.75")	PUSH 6,41 cm ² (1.0 in ²)
LE	-	6,35mm - 12,7mm	25,4(1.00")	
LH	..D	6,35mm	31,75(1.25")	PULL 5,28 cm ² (0.82 in ²)
LS	S,R	6,35mm	31,75(1.25")	

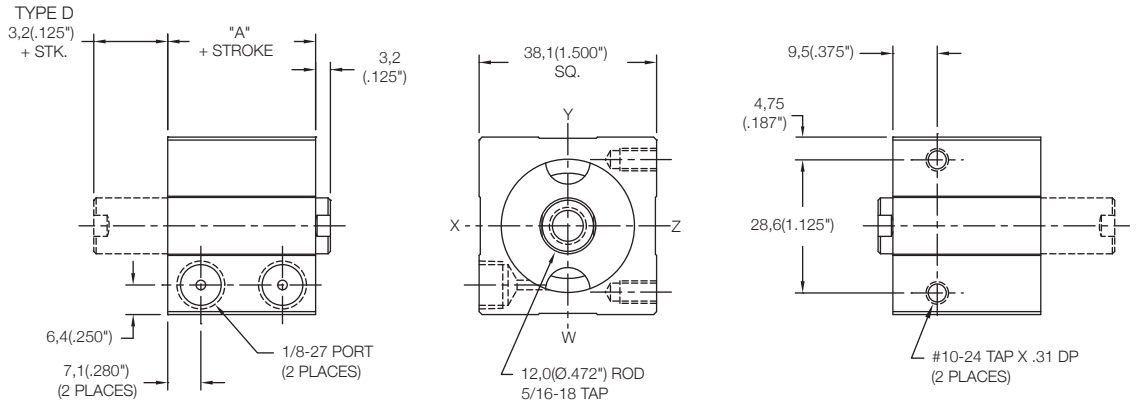

Non Magnetic Side Mount Cylinder "MS"

MODEL	TYPE	STANDARD STROKES	"A"	PISTON AREA
LS	..D	25,4mm - 101,6mm	19,05(.75")	PUSH 6,41 cm ² (1.0 in ²)
LE	-	19,05mm - 101,6mm	25,4(1.00")	
LH	..D	12,7mm - 101,6mm	31,75(1.25")	PULL 5,28 cm ² (0.82 in ²)
LS	S,R	12,7mm - 25,4mm	31,75(1.25")	
LS	S,R	31,8mm - 60,8mm	38,1(1.50")	

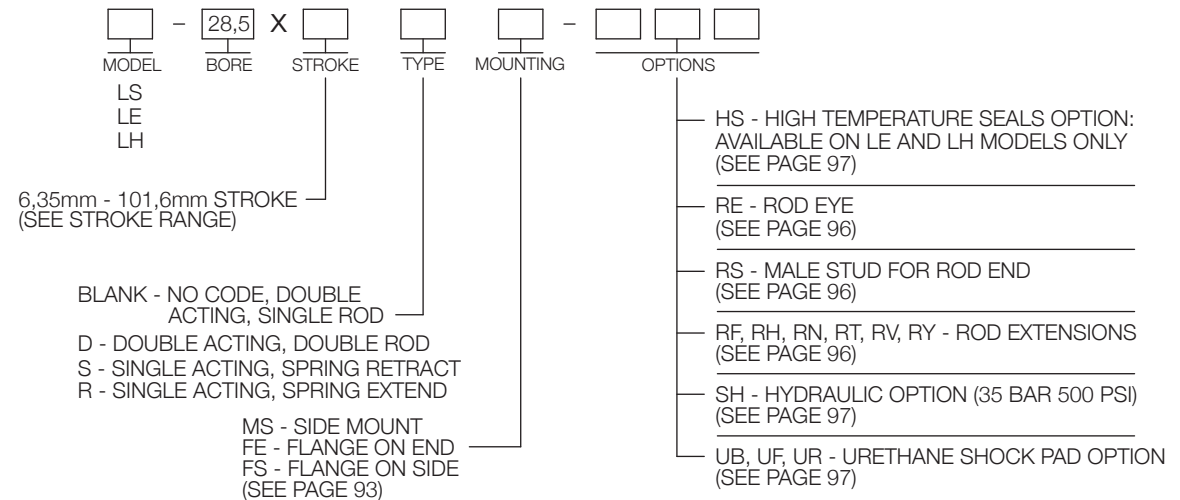
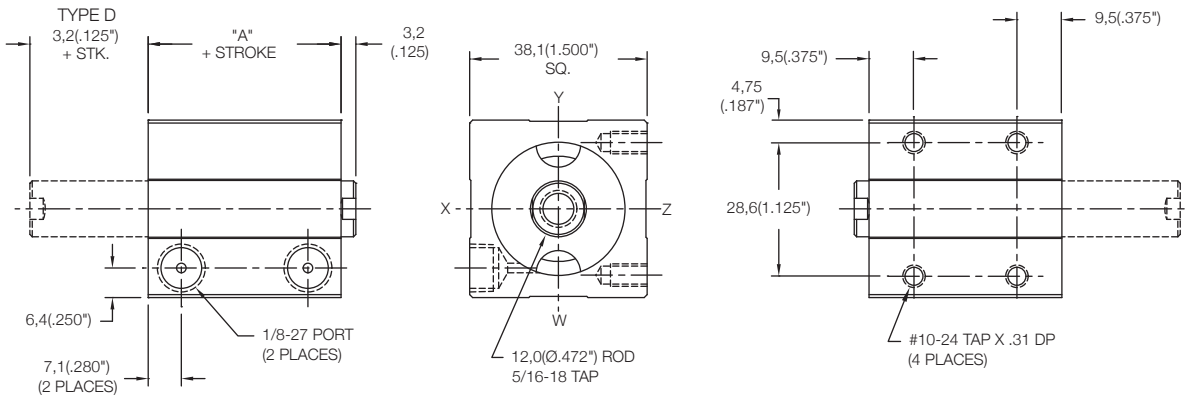

Non Magnetic Front Mount Cylinder "MF"

MODEL	TYPE	STANDARD STROKES	"A"	PISTON AREA
LS	_,D	10mm - 100mm	22,5(0.89")	PUSH 8,04 cm ² (1.25 in ²)
LE	_	5mm - 100mm	27,5(1.08")	
LH	_,D	5mm - 100mm	32,5(1.28")	
LS	S,R	5mm - 25mm	37,5(1.48")	PULL 6,91 cm ² (1.07 in ²)
LS	S,R	26mm - 50mm	42,5(1.68")	

	Standard Threads	"EM" Option
"B"	G1/8 PORT	1/8-27
"C"	M6X1,0	1/4-20
"D"	M6X1,0	1/4-20

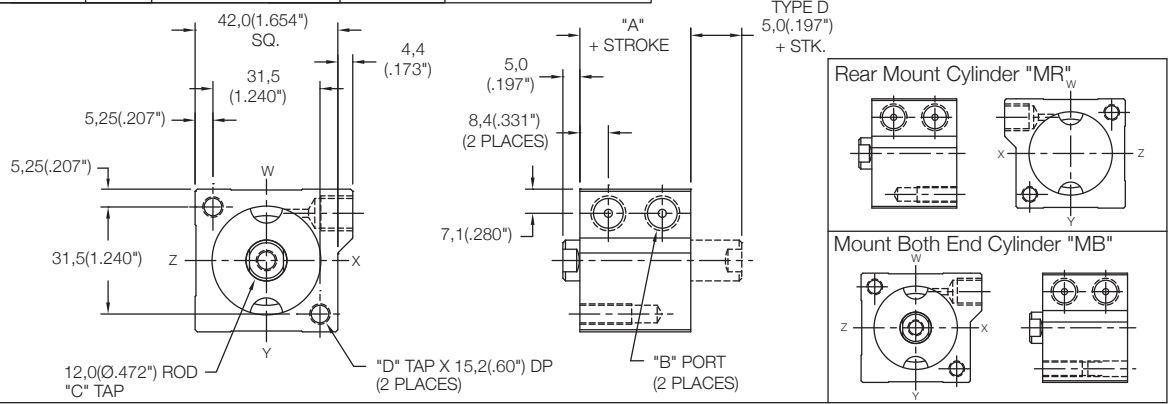

Non Magnetic Thru Mount Cylinder "MT"

MODEL	TYPE	STANDARD STROKES	"A"	PISTON AREA
LS	_,D	10mm - 25mm	22,5(0.89")	PUSH 8,04 cm ² (1.25 in ²)
LE	_	5mm - 20mm	27,5(1.08")	
LH	_,D	5mm - 15mm	32,5(1.28")	
LS	S,R	5mm - 10mm	37,5(1.48")	PULL 6,91 cm ² (1.07 in ²)

	Standard Threads	"EM" Option
"B"	G1/8 PORT	1/8-27
"C"	M6X1,0	1/4-20

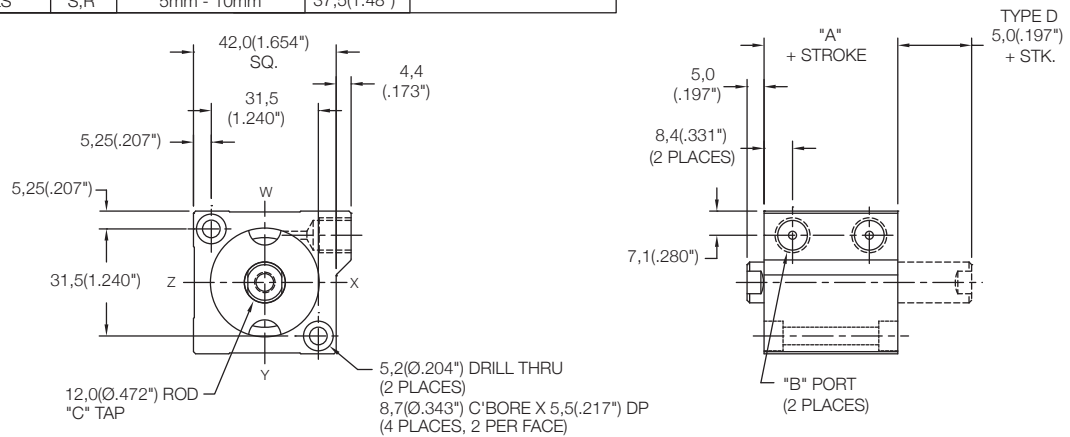

MODEL - BORE X STROKE TYPE MOUNTING OPTIONS

LS
LE
LH

5mm - 100mm STROKE
(SEE STROKE RANGE)

BLANK - NO CODE, DOUBLE ACTING, SINGLE ROD
 D - DOUBLE ACTING, DOUBLE ROD
 S - SINGLE ACTING, SPRING RETRACT
 R - SINGLE ACTING, SPRING EXTEND

MT - THRU MOUNT
 MF - FRONT MOUNT
 MR - REAR MOUNT
 MB - BOTH END MOUNTS
 FF - FRONT FLANGE
 FR - REAR FLANGE
 (FOR FLANGES SEE PAGE 92)

PR - REAR PIVOT
 PL - LONG PIVOT
 (FOR PIVOTS SEE PAGE 94)

EM - INCH THREADS & PORT OPTIONS
 HS - HIGH TEMPERATURE SEALS OPTION:
 AVAILABLE ON LE AND LH MODELS ONLY
 (SEE PAGE 97)
 RE - ROD EYE
 (SEE PAGE 96)
 RS - MALE STUD FOR ROD END
 (SEE PAGE 96)
 RF, RH, RN, RT, RV, RY - ROD EXTENSIONS
 (SEE PAGE 96)
 SH - HYDRAULIC OPTION (35 BAR 500 PSI)
 (SEE PAGE 97)
 UB, UF, UR - URETHANE SHOCK PAD OPTION
 (SEE PAGE 97)

Magnetic Front Mount Cylinder "MF"

MODEL	TYPE	STANDARD STROKES	"A"	PISTON AREA
LS	..D	5mm - 100mm	27,5(1.08")	PUSH 8,04 cm ² (1.25 in ²)
LE	-	5mm - 100mm	32,5(1.28")	
LH	..D	5mm - 100mm	37,5(1.48")	PULL 6,91 cm ² (1.07 in ²)
LS	S,R	5mm - 25mm	42,5(1.68")	
LS	S,R	26mm - 50mm	47,5(1.88")	

	Standard Threads	"EM" Option
"B"	G1/8 PORT	1/8-27
"C"	M6X1,0	1/4-20
"D"	M6X1,0	1/4-20

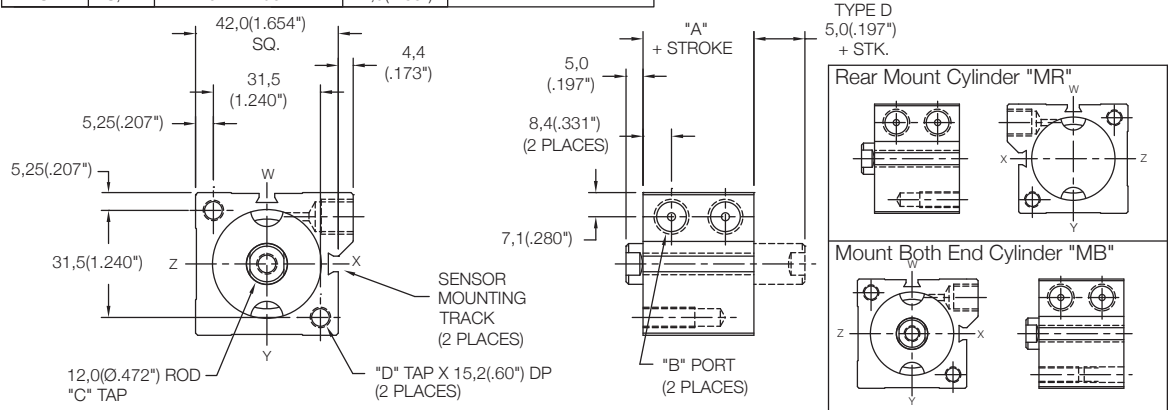

Magnetic Thru Mount Cylinder "MT"

MODEL	TYPE	STANDARD STROKES	"A"	PISTON AREA
LS	..D	5mm - 20mm	27,5(1.08")	PUSH 8,04 cm ² (1.25 in ²)
LE	-	5mm - 15mm	32,5(1.28")	
LH	..D	5mm - 10mm	37,5(1.48")	PULL 6,91 cm ² (1.07 in ²)
LS	S,R	5mm	42,5(1.68")	

	Standard Threads	"EM" Option
"B"	G1/8 PORT	1/8-27
"C"	M6X1,0	1/4-20

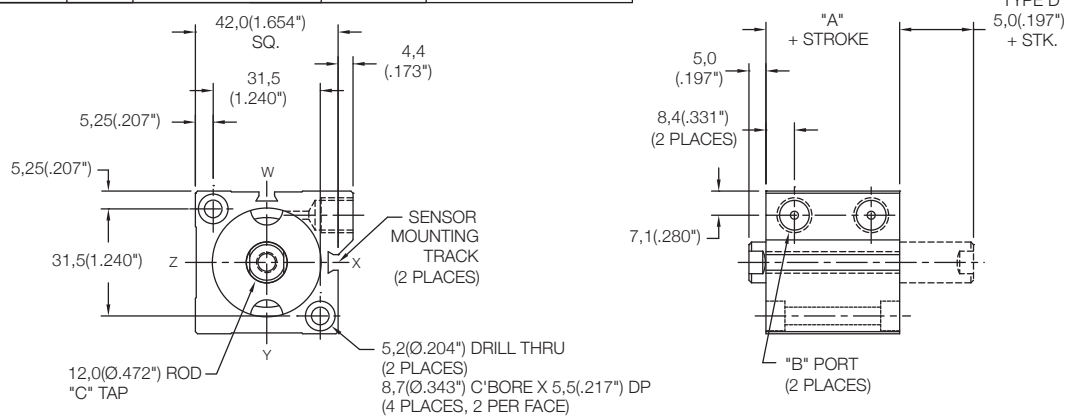

MODEL	-	32	X	STROKE	TYPE	MOUNTING	MAGNETIC	M	-	OPTIONS
LS LE LH				5mm - 100mm STROKE (SEE STROKE RANGE)	BLANK - NO CODE, DOUBLE ACTING, SINGLE ROD D - DOUBLE ACTING, DOUBLE ROD S - SINGLE ACTING, SPRING RETRACT R - SINGLE ACTING, SPRING EXTEND	MT - THRU MOUNT MF - FRONT MOUNT MR - REAR MOUNT MB - BOTH END MOUNTS FF - FRONT FLANGE FR - REAR FLANGE (FOR FLANGES SEE PAGE 92) PR - REAR PIVOT PL - LONG PIVOT (FOR PIVOTS SEE PAGE 94)				SENSORS SOLD SEPARATELY SKS, SKP, SCS, SCP - SOLID STATE LIMIT SENSORS (SEE PAGE 88)
										EM - INCH THREADS & PORT OPTIONS HS - HIGH TEMPERATURE SEALS OPTION: AVAILABLE ON LE AND LH MODELS ONLY (SEE PAGE 97) RE - ROD EYE (SEE PAGE 96) RS - MALE STUD FOR ROD END (SEE PAGE 96) RF, RH, RN, RT, RV, RY - ROD EXTENSIONS (SEE PAGE 96) SH - HYDRAULIC OPTION (35 BAR 500 PSI) (SEE PAGE 97) UB, UF, UR - URETHANE SHOCK PAD OPTION (SEE PAGE 97)

Magnetic Side Mount Cylinder "MS"

MODEL	TYPE	STANDARD STROKES	"A"	PISTON AREA
LS	..D	5mm - 15mm	27,5(1.08")	PUSH 8,04 cm ² (1.25 in ²)
LE	-	5mm - 10mm	32,5(1.28")	
LH	..D	5mm	37,5(1.48")	PULL 6,91 cm ² (1.07 in ²)

	Standard Threads	"EM" Option
"B"	G1/8 PORT	1/8-27
"C"	M6X1,0	1/4-20
"D"	M5X0,8	#10-32

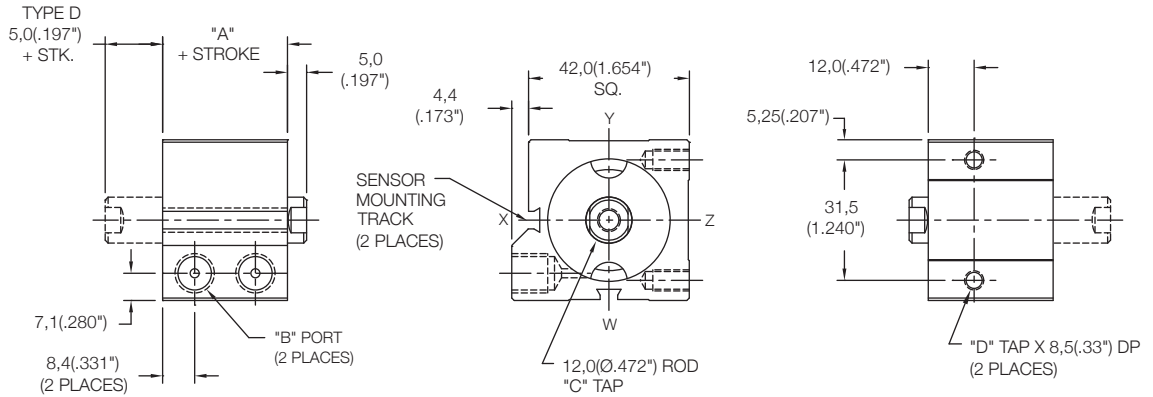

Magnetic Side Mount Cylinder "MS"

MODEL	TYPE	STANDARD STROKES	"A"	PISTON AREA
LS	..D	20mm - 100mm	27,5(1.08")	PUSH 8,04 cm ² (1.25 in ²)
LE	-	15mm - 100mm	32,5(1.28")	
LH	..D	10mm - 100mm	37,5(1.48")	PULL 6,91 cm ² (1.07 in ²)
LS	S,R	5mm - 25mm	42,5(1.68")	
LS	S,R	26mm - 50mm	47,5(1.87")	

	Standard Threads	"EM" Option
"B"	G1/8 PORT	1/8-27
"C"	M6X1,0	1/4-20
"D"	M5X0,8	#10-32

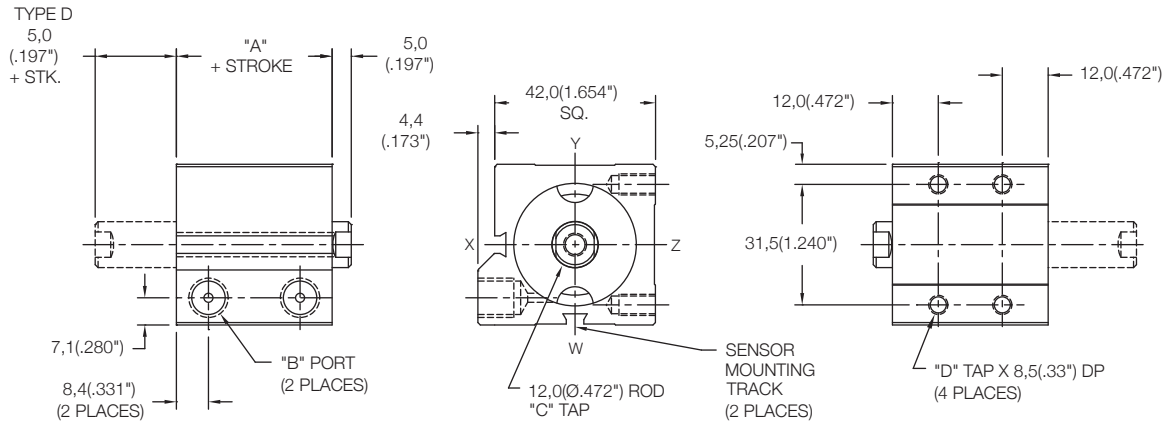

<table border="0"> <tr> <td>MODEL</td> <td>-</td> <td>32</td> <td>X</td> <td>STROKE</td> <td>TYPE</td> <td>MOUNTING</td> <td>MAGNETIC</td> <td>-</td> <td>OPTIONS</td> </tr> <tr> <td>LS LE LH</td> <td></td> <td></td> <td></td> <td></td> <td></td> <td></td> <td>M</td> <td></td> <td></td> </tr> </table> <p>5mm - 100mm STROKE (SEE STROKE RANGE)</p> <p>BLANK - NO CODE, DOUBLE ACTING, SINGLE ROD</p> <p>D - DOUBLE ACTING, DOUBLE ROD S - SINGLE ACTING, SPRING RETRACT R - SINGLE ACTING, SPRING EXTEND</p> <p>MS - SIDE MOUNT FE - FLANGE ON END FS - FLANGE ON SIDE (SEE PAGE 93)</p>	MODEL	-	32	X	STROKE	TYPE	MOUNTING	MAGNETIC	-	OPTIONS	LS LE LH							M			<table border="0"> <tr> <td>EM - INCH THREADS & PORT OPTIONS</td> </tr> <tr> <td>HS - HIGH TEMPERATURE SEALS OPTION: AVAILABLE ON LE AND LH MODELS ONLY (SEE PAGE 97)</td> </tr> <tr> <td>RE - ROD EYE (SEE PAGE 96)</td> </tr> <tr> <td>RS - MALE STUD FOR ROD END (SEE PAGE 96)</td> </tr> <tr> <td>RF, RH, RN, RT, RV, RY - ROD EXTENSIONS (SEE PAGE 96)</td> </tr> <tr> <td>SH - HYDRAULIC OPTION (35 BAR 500 PSI) (SEE PAGE 97)</td> </tr> <tr> <td>UB, UF, UR - URETHANE SHOCK PAD OPTION (SEE PAGE 97)</td> </tr> </table>	EM - INCH THREADS & PORT OPTIONS	HS - HIGH TEMPERATURE SEALS OPTION: AVAILABLE ON LE AND LH MODELS ONLY (SEE PAGE 97)	RE - ROD EYE (SEE PAGE 96)	RS - MALE STUD FOR ROD END (SEE PAGE 96)	RF, RH, RN, RT, RV, RY - ROD EXTENSIONS (SEE PAGE 96)	SH - HYDRAULIC OPTION (35 BAR 500 PSI) (SEE PAGE 97)	UB, UF, UR - URETHANE SHOCK PAD OPTION (SEE PAGE 97)
MODEL	-	32	X	STROKE	TYPE	MOUNTING	MAGNETIC	-	OPTIONS																			
LS LE LH							M																					
EM - INCH THREADS & PORT OPTIONS																												
HS - HIGH TEMPERATURE SEALS OPTION: AVAILABLE ON LE AND LH MODELS ONLY (SEE PAGE 97)																												
RE - ROD EYE (SEE PAGE 96)																												
RS - MALE STUD FOR ROD END (SEE PAGE 96)																												
RF, RH, RN, RT, RV, RY - ROD EXTENSIONS (SEE PAGE 96)																												
SH - HYDRAULIC OPTION (35 BAR 500 PSI) (SEE PAGE 97)																												
UB, UF, UR - URETHANE SHOCK PAD OPTION (SEE PAGE 97)																												

Non Magnetic Side Mount Cylinder "MS"

MODEL	TYPE	STANDARD STROKES	"A"	PISTON AREA
LS	...D	10mm - 20mm	22,5(0.89")	PUSH 8,04 cm ² (1.25 in ²)
LE	-	5mm - 15mm	27,5(1.08")	
LH	...D	5mm - 10mm	32,5(1.28")	PULL 6,91 cm ² (1.07 in ²)
LS	S,R	5mm	37,5(1.48")	

	Standard Threads	"EM" Option
"B"	G1/8 PORT	1/8-27
"C"	M6X1,0	1/4-20
"D"	M5X0,8	#10-32

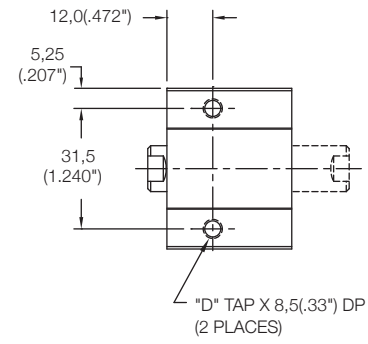
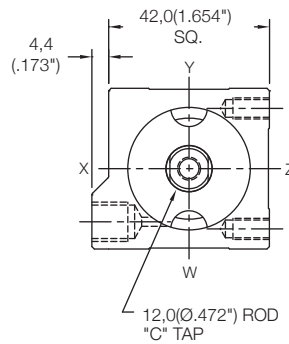
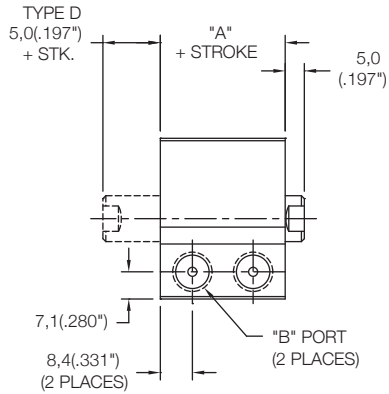

Non Magnetic Side Mount Cylinder "MS"

MODEL	TYPE	STANDARD STROKES	"A"	PISTON AREA
LS	...D	25mm - 100mm	22,5(0.89")	PUSH 8,04 cm ² (1.25 in ²)
LE	-	20mm - 100mm	27,5(1.08")	
LH	...D	15mm - 100mm	32,5(1.28")	PULL 6,91 cm ² (1.07 in ²)
LS	S,R	10mm - 25mm	37,5(1.48")	
LS	S,R	26mm - 50mm	42,5(1.68")	

	Standard Threads	"EM" Option
"B"	G1/8 PORT	1/8-27
"C"	M6X1,0	1/4-20
"D"	M5X0,8	#10-32

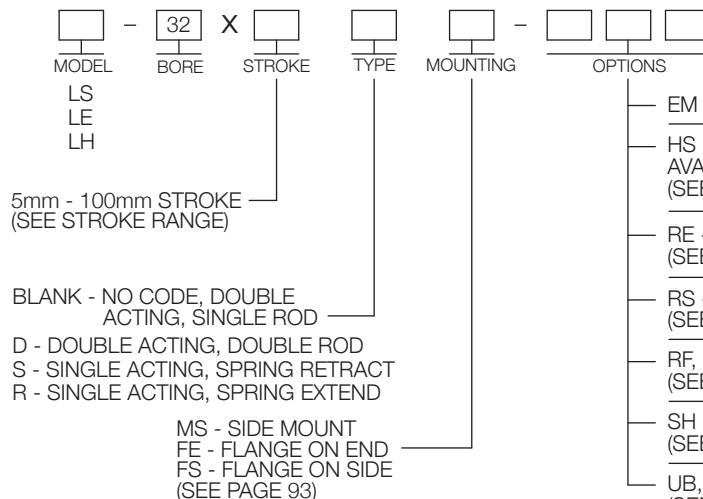
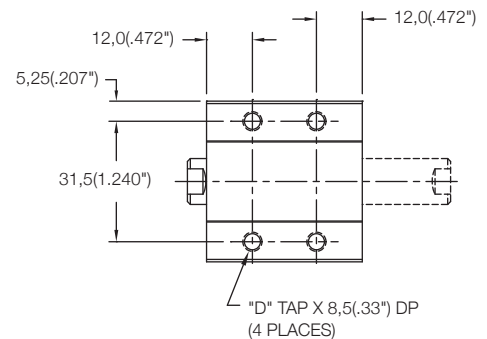
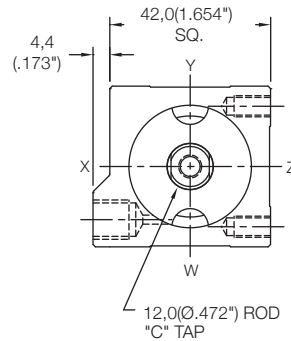
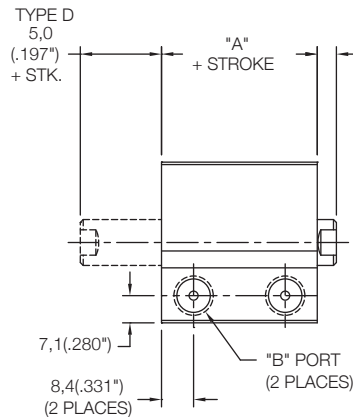

Non Magnetic Front Mount Cylinder "MF"

MODEL	TYPE	STANDARD STROKES	"A"	PISTON AREA
LS	_,D	10mm - 100mm	25,0(0.98")	PUSH 12,56 cm ² (1.95 in ²) PULL 10,55 cm ² (1.64 in ²)
LE	-	5mm - 100mm	35,0(1.38")	
LH	-	5mm - 100mm	40,0(1.58")	PULL 10,55 cm ² (1.64 in ²)
LH	D	5mm - 100mm	45,0(1.78")	
LS	S,R	5mm - 25mm	45,0(1.78")	
LS	S,R	26mm - 50mm	55,0(2.17")	

	Standard Threads	"EM" Option
"B"	G1/8 PORT	1/8-27
"C"	M8X1,25	5/16-18
"D"	M6X1,0	1/4-20

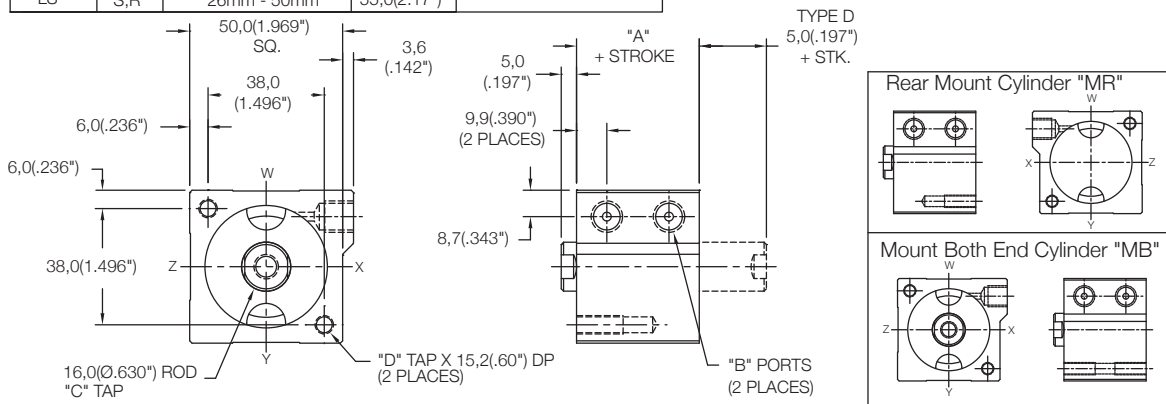

Non Magnetic Thru Mount Cylinder "MT"

MODEL	TYPE	STANDARD STROKES	"A"	PISTON AREA
LS	_,D	10mm - 25mm	25,0(0.98")	PUSH 12,56 cm ² (1.95 in ²) PULL 10,55 cm ² (1.64 in ²)
LE	-	5mm - 15mm	35,0(1.38")	
LH	-	5mm - 10mm	40,0(1.58")	PULL 10,55 cm ² (1.64 in ²)
LH	D	5mm	45,0(1.78")	
LS	S,R	5mm	45,0(1.78")	

	Standard Threads	"EM" Option
"B"	G1/8 PORT	1/8-27
"C"	M8X1,25	5/16-18

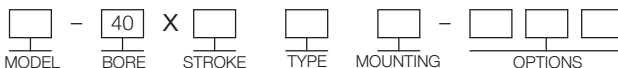
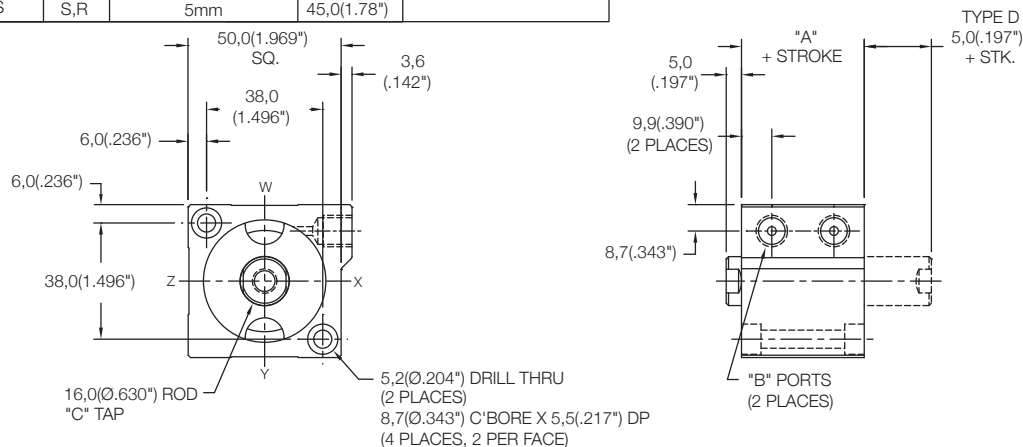

MODEL
LS
LE
LH

5mm - 100mm STROKE
(SEE STROKE RANGE)

BLANK - NO CODE, DOUBLE ACTING, SINGLE ROD
D - DOUBLE ACTING, DOUBLE ROD
S - SINGLE ACTING, SPRING RETRACT
R - SINGLE ACTING, SPRING EXTEND

MT - THRU MOUNT
MF - FRONT MOUNT
MR - REAR MOUNT
MB - BOTH END MOUNTS
FF - FRONT FLANGE
FR - REAR FLANGE
(FOR FLANGES SEE PAGE 92)

PR - REAR PIVOT
PL - LONG PIVOT
(FOR PIVOTS SEE PAGE 94)

EM - INCH THREADS & PORT OPTIONS

HS - HIGH TEMPERATURE SEALS OPTION:
AVAILABLE ON LE AND LH MODELS ONLY
(SEE PAGE 97)

PE - PORT ENLARGEMENT (AVAILABLE W/
"EM" OPTION ONLY = 1/4-18 NPT PORTS)

RE - ROD EYE
(SEE PAGE 96)

RS - MALE STUD FOR ROD END
(SEE PAGE 96)

RF, RH, RN, RT, RV, RY - ROD EXTENSIONS
(SEE PAGE 96)

SH - HYDRAULIC OPTION (35 BAR 500 PSI)
(SEE PAGE 97)

UB, UF, UR - URETHANE SHOCK PAD OPTION
(SEE PAGE 97)

Magnetic Front Mount Cylinder "MF"

MODEL	TYPE	STANDARD STROKES	"A"	PISTON AREA
LS	_D	5mm - 100mm	30,0(1.18")	PUSH 12,56 cm ² (1.95 in ²) PULL 10,55 cm ² (1.64 in ²)
LE	-	5mm - 100mm	40,0(1.58")	
LH	-	5mm - 100mm	45,0(1.78")	PULL 10,55 cm ² (1.64 in ²)
LH	D	5mm - 100mm	50,0(1.98")	
LS	S,R	5mm - 25mm	50,0(1.97")	
LS	S,R	26mm - 50mm	60,0(2.36")	

	Standard Threads	"EM" Option
"B"	G1/8 PORT	1/8-27
"C"	M8X1,25	5/16-18
"D"	M6X1,0	1/4-20

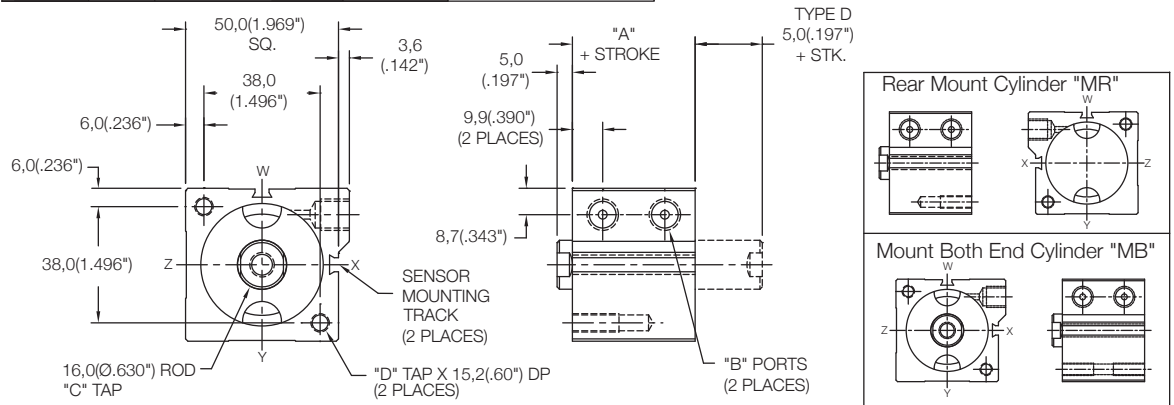

Magnetic Thru Mount Cylinder "MT"

MODEL	TYPE	STANDARD STROKES	"A"	PISTON AREA
LS	_D	5mm - 20mm	30,0(1.18")	PUSH 12,56 cm ² (1.95 in ²) PULL 10,55 cm ² (1.64 in ²)
LE	-	5mm - 10mm	40,0(1.58")	
LH	-	5mm	45,0(1.78")	

	Standard Threads	"EM" Option
"B"	G1/8 PORT	1/8-27
"C"	M8X1,25	5/16-18

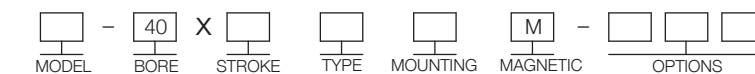
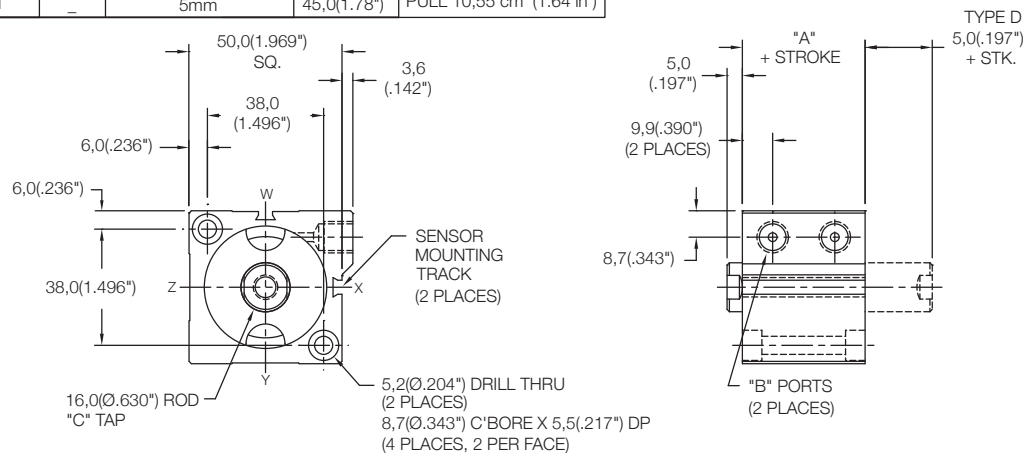

- MODEL**
 LS
 LE
 LH
- BORE**
 40
 5mm - 100mm STROKE
 (SEE STROKE RANGE)
- STROKE**
 BLANK - NO CODE, DOUBLE ACTING, SINGLE ROD
 D - DOUBLE ACTING, DOUBLE ROD
 S - SINGLE ACTING, SPRING RETRACT
 R - SINGLE ACTING, SPRING EXTEND
- TYPE**
 MT - THRU MOUNT
 MF - FRONT MOUNT
 MR - REAR MOUNT
 MB - BOTH END MOUNTS
 FF - FRONT FLANGE
 FR - REAR FLANGE
 (FOR FLANGES SEE PAGE 92)
- MOUNTING**
 PR - REAR PIVOT
 PL - LONG PIVOT
 (FOR PIVOTS SEE PAGE 94)
- MAGNETIC**
 M
- OPTIONS**

SENSORS SOLD SEPARATELY
 SKS, SKP, SCS, SCP - SOLID STATE LIMIT SENSORS (SEE PAGE 88)

- EM - INCH THREADS & PORT OPTIONS
- HS - HIGH TEMPERATURE SEALS OPTION: AVAILABLE ON LE AND LH MODELS ONLY (SEE PAGE 97)
- PE - PORT ENLARGEMENT (AVAILABLE W/ "EM" OPTION ONLY = 1/4-18 NPT PORTS)
- RE - ROD EYE (SEE PAGE 96)
- RS - MALE STUD FOR ROD END (SEE PAGE 96)
- RF, RH, RN, RT, RV, RY - ROD EXTENSIONS (SEE PAGE 96)
- SH - HYDRAULIC OPTION (35 BAR 500 PSI) (SEE PAGE 97)
- UB, UF, UR - URETHANE SHOCK PAD OPTION (SEE PAGE 97)

Magnetic Side Mount Cylinder "MS"

MODEL	TYPE	STANDARD STROKES	"A"	PISTON AREA
LS	_,D	5mm - 15mm	30,0(1.18")	PUSH 12,56 cm ² (1.95 in ²)
LE	-	5mm	40,0(1.58")	PULL 10,55 cm ² (1.64 in ²)

	Standard Threads	"EM" Option
"B"	G1/8 PORT	1/8-27
"C"	M8X1,25	5/16-18
"D"	M6X1,0	1/4-20

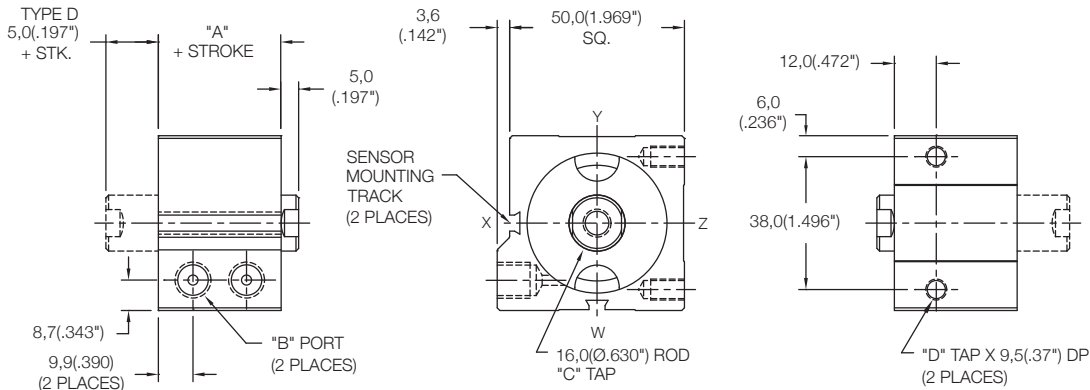

Magnetic Side Mount Cylinder "MS"

MODEL	TYPE	STANDARD STROKES	"A"	PISTON AREA
LS	_,D	20mm - 100mm	30,0(1.18")	PUSH 12,56 cm ² (1.95 in ²)
LE	-	10mm - 100mm	40,0(1.58")	PULL 10,55 cm ² (1.64 in ²)
LH	-	5mm - 100mm	45,0(1.78")	
LH	D	5mm - 100mm	50,0(1.97")	
LS	S,R	5mm - 25mm	50,0(1.97")	
LS	S,R	26mm - 50mm	60,0(2.36")	

	Standard Threads	"EM" Option
"B"	G1/8 PORT	1/8-27
"C"	M8X1,25	5/16-18
"D"	M6X1,0	1/4-20

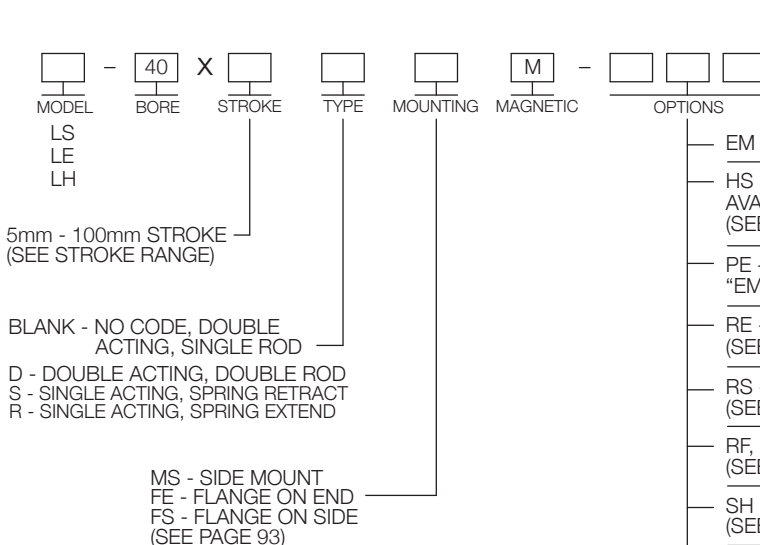
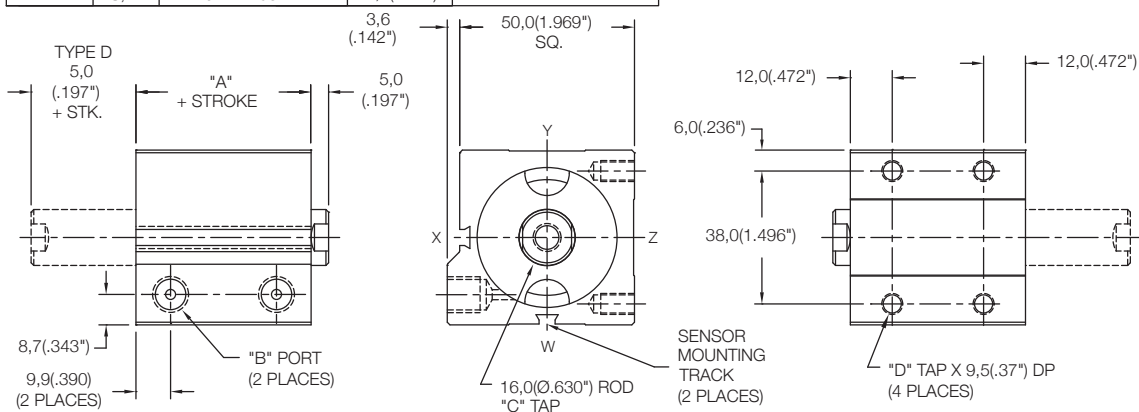

SENSORS SOLD SEPARATELY
SKS, SKP, SCS, SCP - SOLID STATE
LIMIT SENSORS (SEE PAGE 88)

- EM - INCH THREADS & PORT OPTIONS
- HS - HIGH TEMPERATURE SEALS OPTION: AVAILABLE ON LE AND LH MODELS ONLY (SEE PAGE 97)
- PE - PORT ENLARGEMENT (AVAILABLE W/ "EM" OPTION ONLY = 1/4-18 NPT PORTS)
- RE - ROD EYE (SEE PAGE 96)
- RS - MALE STUD FOR ROD END (SEE PAGE 96)
- RF, RH, RN, RT, RV, RY - ROD EXTENSIONS (SEE PAGE 96)
- SH - HYDRAULIC OPTION (35 BAR 500 PSI) (SEE PAGE 97)
- UB, UF, UR - URETHANE SHOCK PAD OPTION (SEE PAGE 97)

Non Magnetic Side Mount Cylinder "MS"

MODEL	TYPE	STANDARD STROKES	"A"	PISTON AREA
LS	...D	10mm - 20mm	25,0(0.98")	PUSH 12,56 cm ² (1.95 in ²)
LE	-	5mm - 10mm	35,0(1.38")	PULL 10,55 cm ² (1.64 in ²)
LH	-	5mm	40,0(1.58")	

	Standard Threads	"EM" Option
"B"	G1/8 PORT	1/8-27
"C"	M8X1,25	5/16-18
"D"	M6X1,0	1/4-20

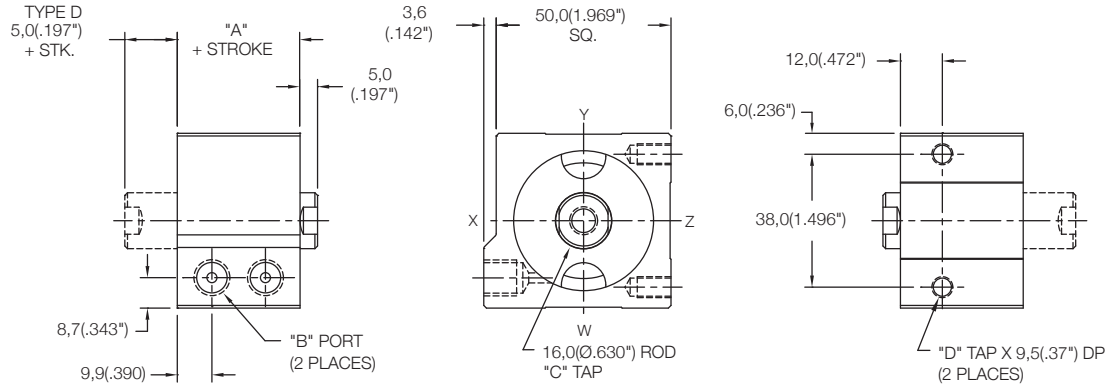

Non Magnetic Side Mount Cylinder "MS"

MODEL	TYPE	STANDARD STROKES	"A"	PISTON AREA
LS	...D	25mm - 100mm	25,0(0.98")	PUSH 12,56 cm ² (1.95 in ²)
LE	-	15mm - 100mm	35,0(1.38")	PULL 10,55 cm ² (1.64 in ²)
LH	-	10mm - 100mm	40,0(1.58")	
LH	D	5mm - 100mm	45,0(1.78")	
LS	S,R	5mm - 25mm	45,0(1.78")	
LS	S,R	26mm - 50mm	55,0(2.17")	

	Standard Threads	"EM" Option
"B"	G1/8 PORT	1/8-27
"C"	M8X1,25	5/16-18
"D"	M6X1,0	1/4-20

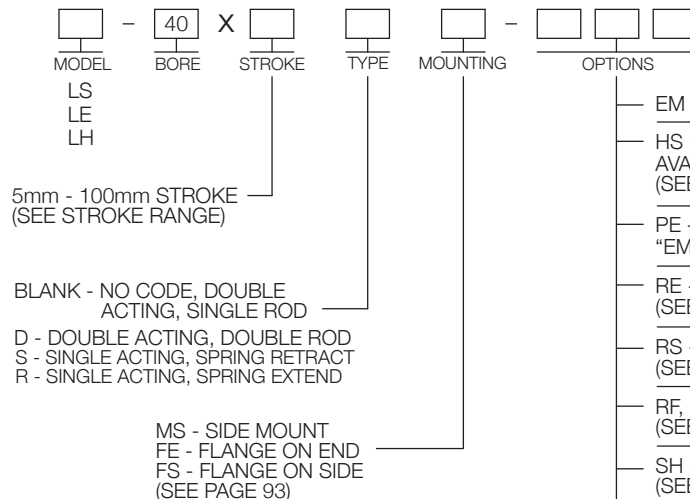
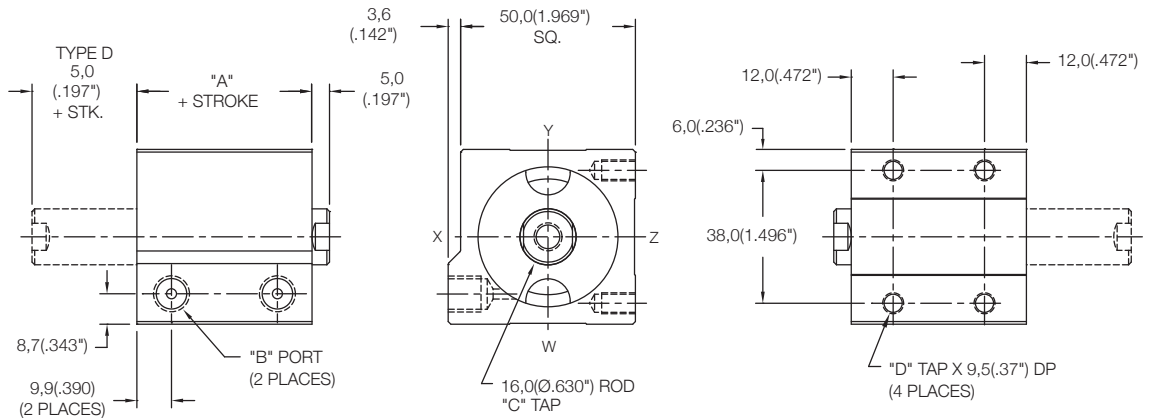

- EM - INCH THREADS & PORT OPTIONS
- HS - HIGH TEMPERATURE SEALS OPTION: AVAILABLE ON LE AND LH MODELS ONLY (SEE PAGE 97)
- PE - PORT ENLARGEMENT (AVAILABLE W/ "EM" OPTION ONLY = 1/4-18 NPT PORTS)
- RE - ROD EYE (SEE PAGE 96)
- RS - MALE STUD FOR ROD END (SEE PAGE 96)
- RF, RH, RN, RT, RV, RY - ROD EXTENSIONS (SEE PAGE 96)
- SH - HYDRAULIC OPTION (35 BAR 500 PSI) (SEE PAGE 97)
- UB, UF, UR - URETHANE SHOCK PAD OPTION (SEE PAGE 97)

Non Magnetic Front Mount Cylinder "MF"

MODEL	TYPE	STANDARD STROKES	"A"	PISTON AREA
LS	_,D	10mm - 100mm	28,5(1.12")	PUSH 19,63 cm ² (3.04 in ²)
LE	_	5mm - 100mm	38,5(1.52")	
LH	_	5mm - 100mm	43,5(1.72")	PULL 17,62 cm ² (2.73 in ²)
LH	D	5mm - 100mm	48,5(1.91")	
LS	S,R	5mm - 25mm	48,5(1.91")	
LS	S,R	26mm - 50mm	58,5(2.31")	

	Standard Threads	"EM" Option
"B"	G1/8 PORT	1/8-27
"C"	M10X1,5	3/8-24
"D"	M8X1,25	5/16-18

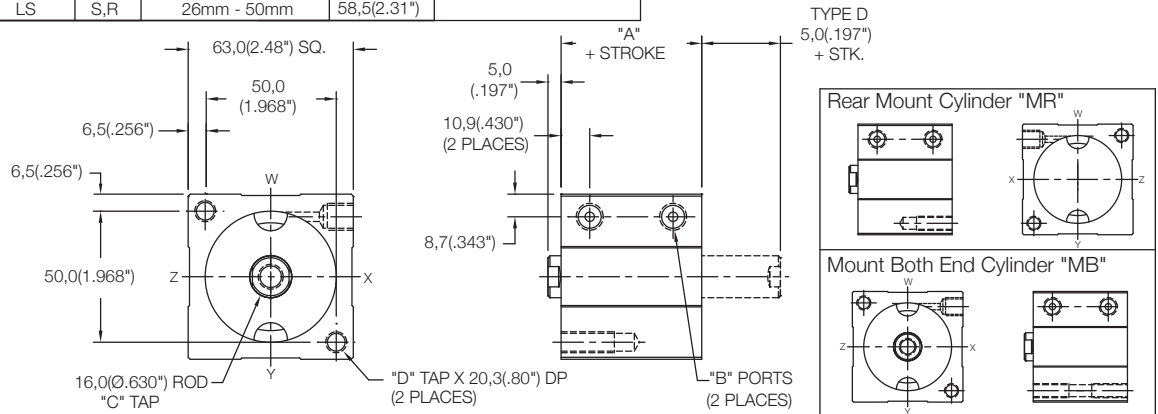

Non Magnetic Thru Mount Cylinder "MT"

MODEL	TYPE	STANDARD STROKES	"A"	PISTON AREA
LS	_,D	10mm - 40mm	28,5(1.12")	PUSH 19,63 cm ² (3.04 in ²)
LE	_	5mm - 30mm	38,5(1.52")	
LH	_	5mm - 25mm	43,5(1.72")	PULL 17,62 cm ² (2.73 in ²)
LH	D	5mm - 20mm	48,5(1.91")	
LS	S,R	5mm - 20mm	48,5(1.91")	

	Standard Threads	"EM" Option
"B"	G1/8 PORT	1/8-27
"C"	M10X1,5	3/8-24

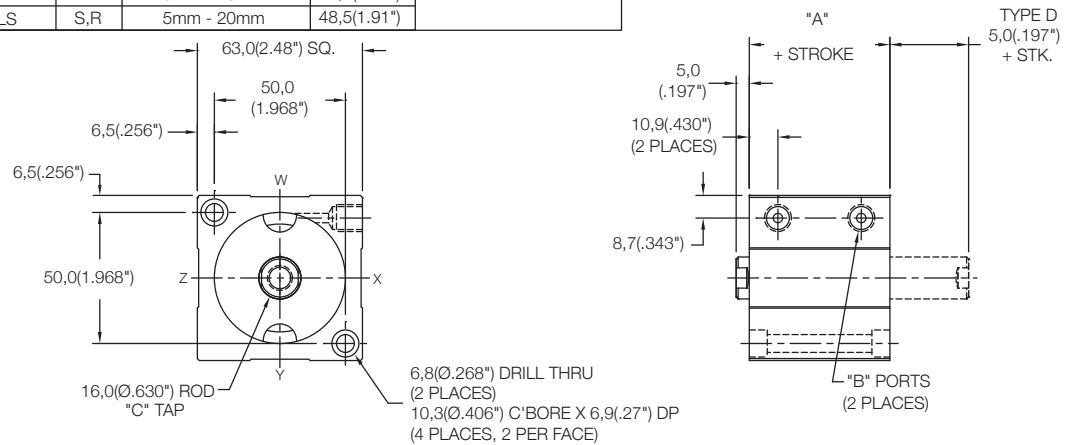

MODEL
LS
LE
LH

5mm - 100mm STROKE
(SEE STROKE RANGE)

BLANK - NO CODE, DOUBLE
ACTING, SINGLE ROD

D - DOUBLE ACTING, DOUBLE ROD
S - SINGLE ACTING, SPRING RETRACT
R - SINGLE ACTING, SPRING EXTEND

MT - THRU MOUNT
MF - FRONT MOUNT
MR - REAR MOUNT
MB - BOTH END MOUNTS
FF - FRONT FLANGE
FR - REAR FLANGE
(FOR FLANGES SEE PAGE 92)

PR - REAR PIVOT
PL - LONG PIVOT
(FOR PIVOTS SEE PAGE 94)

EM - INCH THREADS & PORT OPTIONS

HS - HIGH TEMPERATURE SEALS OPTION:
AVAILABLE ON LE AND LH MODELS ONLY
(SEE PAGE 97)

PE - PORT ENLARGEMENT (AVAILABLE W/
"EM" OPTION ONLY = 1/4-18 NPT PORTS)

RE - ROD EYE
(SEE PAGE 96)

RS - MALE STUD FOR ROD END
(SEE PAGE 96)

RF, RH, RN, RT, RV, RY - ROD EXTENSIONS
(SEE PAGE 96)

SH - HYDRAULIC OPTION (35 BAR 500 PSI)
(SEE PAGE 97)

UB, UF, UR - URETHANE SHOCK PAD OPTION
(SEE PAGE 97)

Magnetic Front Mount Cylinder "MF"

MODEL	TYPE	STANDARD STROKES	"A"	PISTON AREA
LS	..D	5mm - 100mm	33,5(1.32")	PUSH 19,63 cm ² (3.04 in ²)
LE	-	5mm - 100mm	43,5(1.72")	
LH	-	5mm - 100mm	48,5(1.91")	PULL 17,62 cm ² (2.73 in ²)
LH	D	5mm - 100mm	53,5(2.11")	
LS	S,R	5mm - 25mm	53,5(2.11")	
LS	S,R	26mm - 50mm	63,5(2.50")	

	Standard Threads	"EM" Option
"B"	G1/8 PORT	1/8-27
"C"	M10X1,5	3/8-24
"D"	M8X1,25	5/16-18

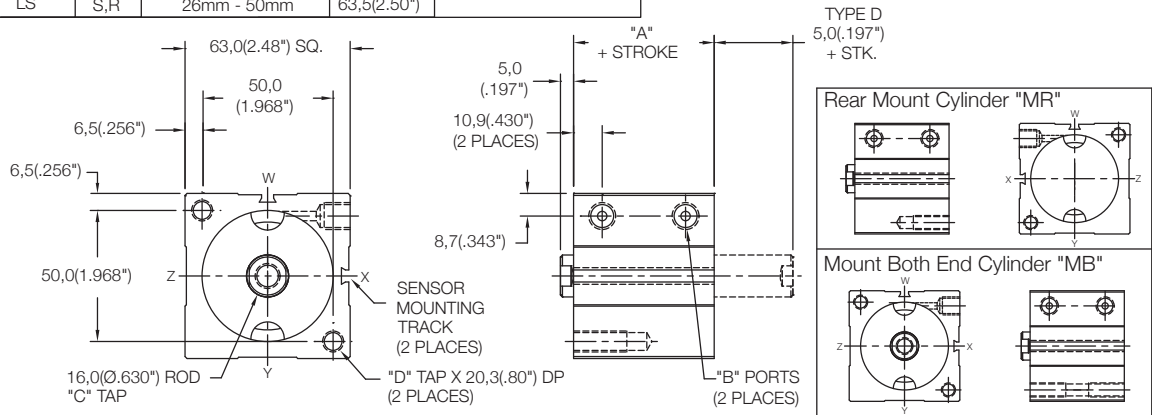

Magnetic Thru Mount Cylinder "MT"

MODEL	TYPE	STANDARD STROKES	"A"	PISTON AREA
LS	..D	5mm - 35mm	33,5(1.32")	PUSH 19,63 cm ² (3.04 in ²)
LE	-	5mm - 25mm	43,5(1.72")	
LH	-	5mm - 20mm	48,5(1.91")	PULL 17,62 cm ² (2.73 in ²)
LH	D	5mm - 15mm	53,5(2.11")	
LS	S,R	5mm - 15mm	53,5(2.11")	

	Standard Threads	"EM" Option
"B"	G1/8 PORT	1/8-27
"C"	M10X1,5	3/8-24

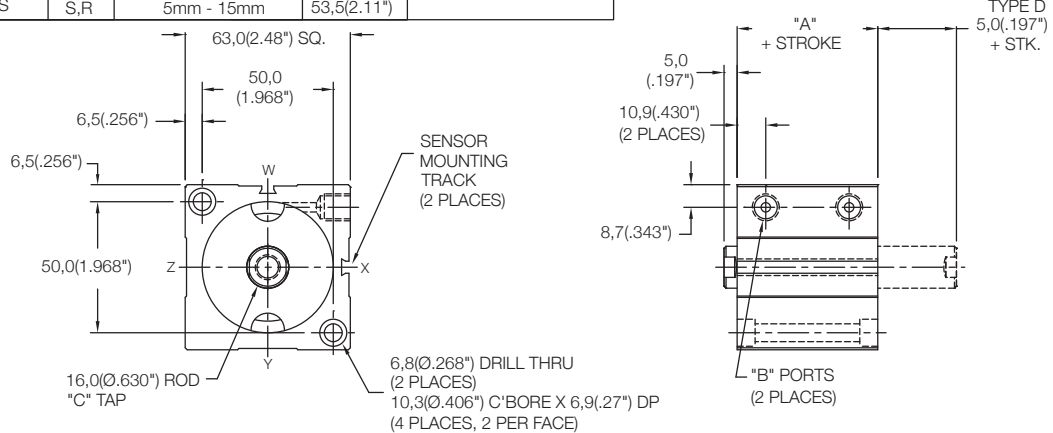

<p>MODEL: LS, LE, LH</p> <p>BORE: 50</p> <p>STROKE: 5mm - 100mm (SEE STROKE RANGE)</p> <p>TYPE: BLANK - NO CODE, DOUBLE ACTING, SINGLE ROD; D - DOUBLE ACTING, DOUBLE ROD; S - SINGLE ACTING, SPRING RETRACT; R - SINGLE ACTING, SPRING EXTEND</p> <p>MOUNTING: MT - THRU MOUNT; MF - FRONT MOUNT; MR - REAR MOUNT; MB - BOTH END MOUNTS; FF - FRONT FLANGE; FR - REAR FLANGE (FOR FLANGES SEE PAGE 92); PR - REAR PIVOT; PL - LONG PIVOT (FOR PIVOTS SEE PAGE 94)</p>	<p>MAGNETIC: M</p> <p>OPTIONS: EM - INCH THREADS & PORT OPTIONS; HS - HIGH TEMPERATURE SEALS OPTION: AVAILABLE ON LE AND LH MODELS ONLY (SEE PAGE 97); PE - PORT ENLARGEMENT (AVAILABLE W/ "EM" OPTION ONLY = 1/4-18 NPT PORTS); RE - ROD EYE (SEE PAGE 96); RS - MALE STUD FOR ROD END (SEE PAGE 96); RF, RH, RN, RT, RV, RY - ROD EXTENSIONS (SEE PAGE 96); SH - HYDRAULIC OPTION (35 BAR 500 PSI) (SEE PAGE 97); UB, UF, UR - URETHANE SHOCK PAD OPTION (SEE PAGE 97)</p>	<p>SENSORS SOLD SEPARATELY: SKS, SKP, SCS, SCP - SOLID STATE LIMIT SENSORS (SEE PAGE 88)</p>
--	--	--

Magnetic Side Mount Cylinder "MS"

MODEL	TYPE	STANDARD STROKES	"A"	PISTON AREA
LS	_,D	5mm - 15mm	33,5(1.32")	PUSH 19,63 cm ² (3.04 in ²)
LE	_	5mm	43,5(1.72")	PULL 17,62 cm ² (2.73 in ²)

	Standard Threads	"EM" Option
"B"	G1/8 PORT	1/8-27
"C"	M10X1,5	3/8-24
"D"	M8X1,25	5/16-18

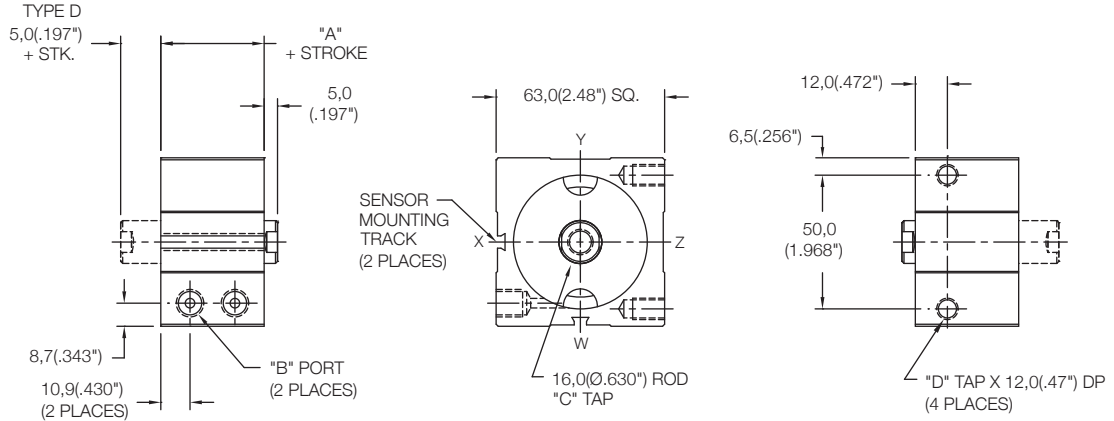

Magnetic Side Mount Cylinder "MS"

MODEL	TYPE	STANDARD STROKES	"A"	PISTON AREA
LS	_,D	20mm - 100mm	33,5(1.32")	PUSH 19,63 cm ² (3.04 in ²)
LE	_	10mm - 100mm	43,5(1.72")	
LH	_	5mm - 100mm	48,5(1.91")	PULL 17,62 cm ² (2.73 in ²)
LH	D	5mm - 100mm	53,5(2.11")	
LS	S,R	5mm - 25mm	53,5(2.11")	
LS	S,R	26mm - 50mm	63,5(2.50")	

	Standard Threads	"EM" Option
"B"	G1/8 PORT	1/8-27
"C"	M10X1,5	3/8-24
"D"	M8X1,25	5/16-18

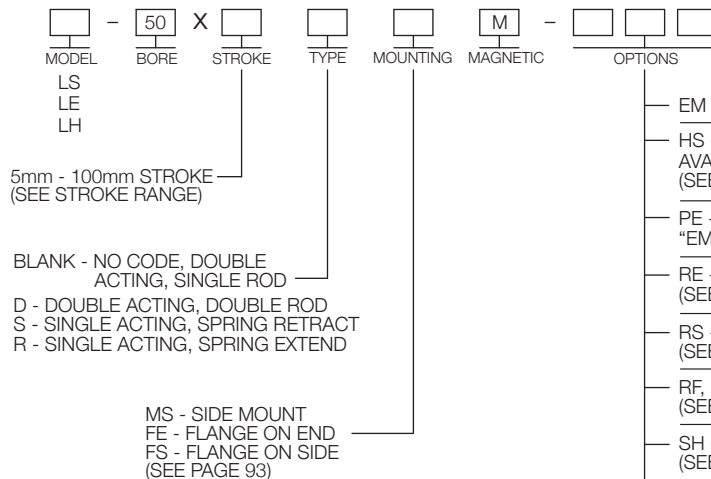
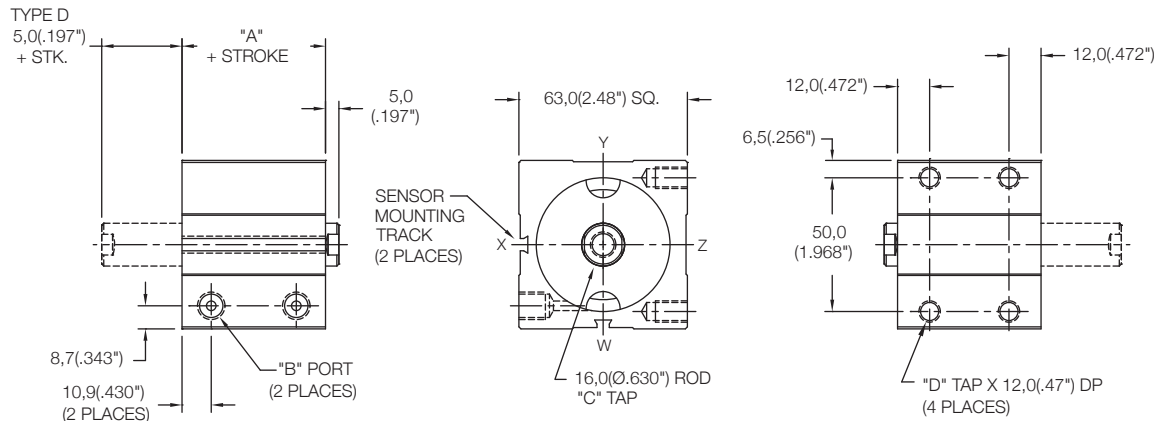

SENSORS SOLD SEPARATELY
SKS, SKP, SCS, SCP - SOLID STATE
LIMIT SENSORS (SEE PAGE 88)

Non Magnetic Side Mount Cylinder "MS"

MODEL	TYPE	STANDARD STROKES	"A"	PISTON AREA
LS	_D	10mm - 20mm	28,5(1.12")	PUSH 19,63 cm ² (3.04 in ²)
LE	-	5mm - 10mm	38,5(1.52")	PULL 17,62 cm ² (2.73 in ²)
LH	-	5mm	43,5(1.72")	

	Standard Threads	"EM" Option
"B"	G1/8 PORT	1/8-27
"C"	M10X1,5	3/8-24
"D"	M8X1,25	5/16-18

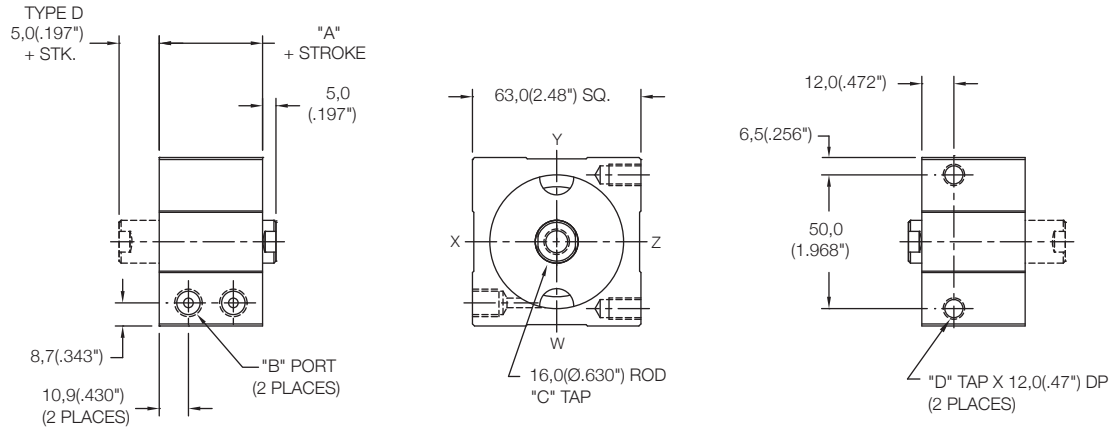

Non Magnetic Side Mount Cylinder "MS"

MODEL	TYPE	STANDARD STROKES	"A"	PISTON AREA
LS	_D	25mm - 100mm	28,5(1.12")	PUSH 19,63 cm ² (3.04 in ²)
LE	-	15mm - 100mm	38,5(1.52")	PULL 17,62 cm ² (2.73 in ²)
LH	-	10mm - 100mm	43,5(1.72")	
LH	D	5mm - 100mm	48,5(1.91")	
LS	S,R	5mm - 25mm	48,5(1.91")	
LS	S,R	26mm - 50mm	58,5(2.31")	

	Standard Threads	"EM" Option
"B"	G1/8 PORT	1/8-27
"C"	M10X1,5	3/8-24
"D"	M8X1,25	5/16-18

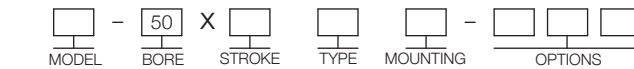
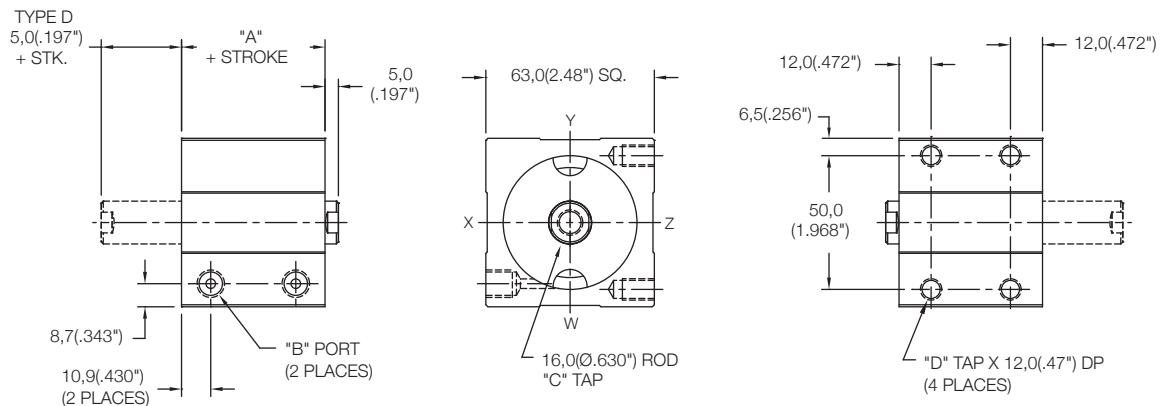

LS
LE
LH

5mm - 100mm STROKE
(SEE STROKE RANGE)

BLANK - NO CODE, DOUBLE ACTING, SINGLE ROD

D - DOUBLE ACTING, DOUBLE ROD

S - SINGLE ACTING, SPRING RETRACT

R - SINGLE ACTING, SPRING EXTEND

MS - SIDE MOUNT

FE - FLANGE ON END

FS - FLANGE ON SIDE
(SEE PAGE 93)

EM - INCH THREADS & PORT OPTIONS

HS - HIGH TEMPERATURE SEALS OPTION:
AVAILABLE ON LE AND LH MODELS ONLY
(SEE PAGE 97)

PE - PORT ENLARGEMENT (AVAILABLE W/
"EM" OPTION ONLY = 1/4-18 NPT PORTS)

RE - ROD EYE
(SEE PAGE 96)

RS - MALE STUD FOR ROD END
(SEE PAGE 96)

RF, RH, RN, RT, RV, RY - ROD EXTENSIONS
(SEE PAGE 96)

SH - HYDRAULIC OPTION (35 BAR 500 PSI)
(SEE PAGE 97)

UB, UF, UR - URETHANE SHOCK PAD OPTION
(SEE PAGE 97)

Non Magnetic Front Mount Cylinder "MF"

MODEL	TYPE	STANDARD STROKES	"A"	PISTON AREA
LS	...D	10mm - 100mm	32,0(1.26")	PUSH 31,17 cm ² (4.83 in ²)
LE	-	5mm - 100mm	42,0(1.66")	
LH	...D	5mm - 100mm	52,0(2.05")	PULL 28,03 cm ² (4.34 in ²)

	Standard Threads	"EM" Option
"B"	G1/8 PORT	1/8-27
"C"	M12X1,75	1/2-13
"D"	M10X1,5	3/8-24

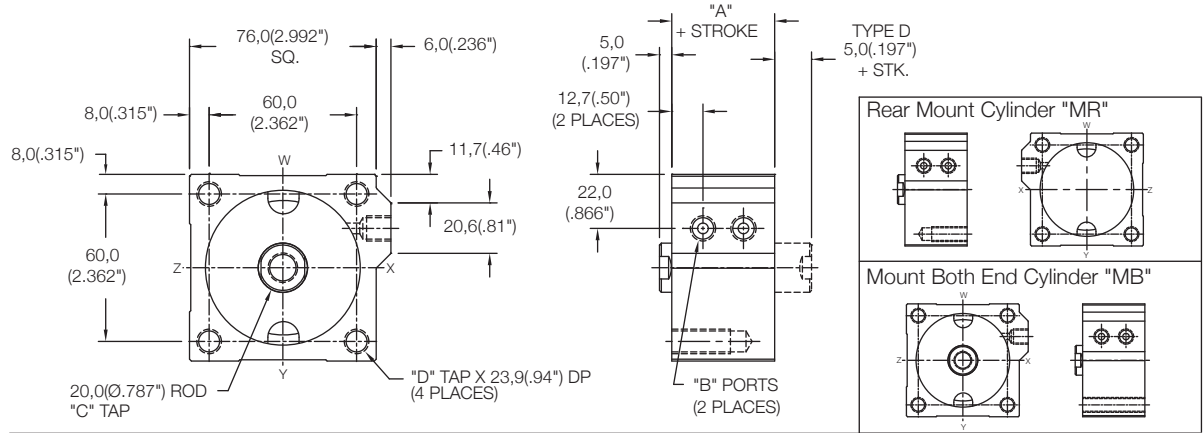

Non Magnetic Thru Mount Cylinder "MT"

MODEL	TYPE	STANDARD STROKES	"A"	PISTON AREA
LS	...D	10mm - 40mm	32,0(1.26")	PUSH 31,17 cm ² (4.83 in ²)
LE	-	5mm - 30mm	42,0(1.66")	
LH	...D	5mm - 20mm	52,0(2.05")	PULL 28,03 cm ² (4.34 in ²)

	Standard Threads	"EM" Option
"B"	G1/8 PORT	1/8-27
"C"	M12X1,75	1/2-13

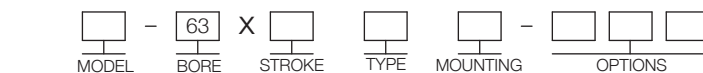
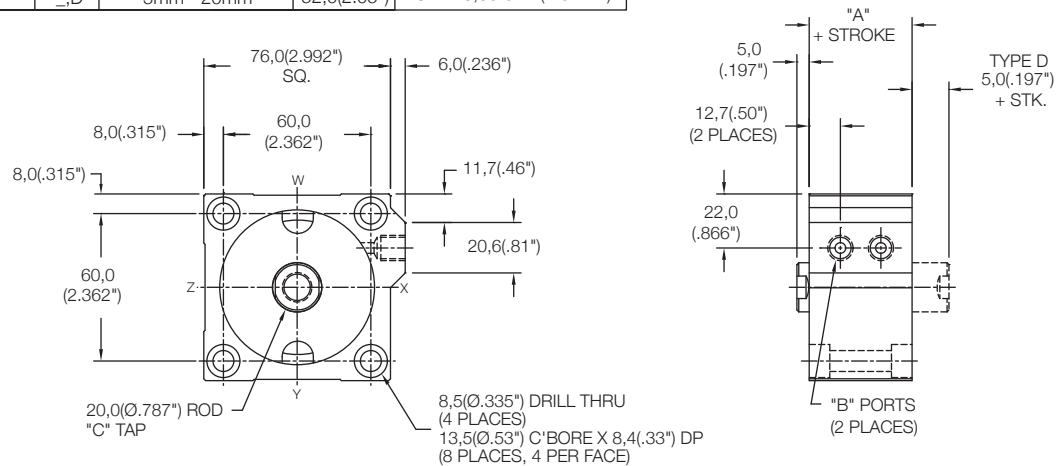

- MODEL: LS, LE, LH
- BORE: 63
- STROKE: 5mm - 100mm STROKE (SEE STROKE RANGE)
- TYPE: BLANK - NO CODE, DOUBLE ACTING, SINGLE ROD; D - DOUBLE ACTING, DOUBLE ROD
- MOUNTING: MT - THRU MOUNT; MF - FRONT MOUNT; MR - REAR MOUNT; MB - BOTH END MOUNTS; FF - FRONT FLANGE; FR - REAR FLANGE (FOR FLANGES SEE PAGE 92); PR - REAR PIVOT; PL - LONG PIVOT (FOR PIVOTS SEE PAGE 94)
- OPTIONS:
 - EM - INCH THREADS & PORT OPTIONS
 - HS - HIGH TEMPERATURE SEALS OPTION: AVAILABLE ON LE AND LH MODELS ONLY (SEE PAGE 97)
 - PE - PORT ENLARGEMENT (AVAILABLE W/ "EM" OPTION ONLY = 1/4-18 NPT PORTS)
 - RE - ROD EYE (SEE PAGE 96)
 - RS - MALE STUD FOR ROD END (SEE PAGE 96)
 - RF, RH, RN, RT, RV, RY - ROD EXTENSIONS (SEE PAGE 96)
 - SH - HYDRAULIC OPTION (35 BAR 500 PSI) (SEE PAGE 97)
 - UB, UF, UR - URETHANE SHOCK PAD OPTION (SEE PAGE 97)

Magnetic Front Mount Cylinder "MF"

MODEL	TYPE	STANDARD STROKES	"A"	PISTON AREA
LS	...D	10mm - 100mm	37,0(1.46")	PUSH 31,17 cm ² (4.83 in ²)
LE	-	5mm - 100mm	47,0(1.85")	
LH	...D	5mm - 100mm	57,0(2.25")	PULL 28,03 cm ² (4.34 in ²)

	Standard Threads	"EM" Option
"B"	G1/8 PORT	1/8-27
"C"	M12X1,75	1/2-13
"D"	M10X1,5	3/8-24

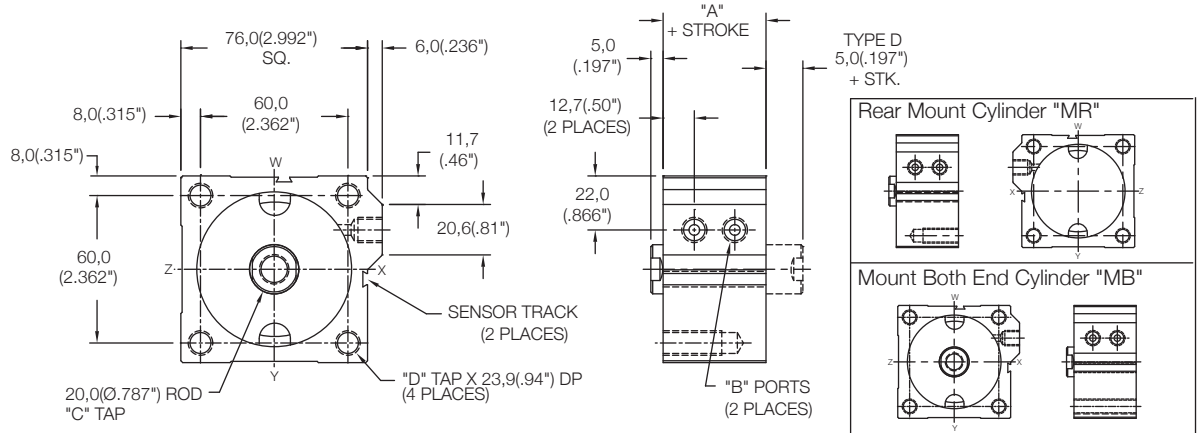

Magnetic Thru Mount Cylinder "MT"

MODEL	TYPE	STANDARD STROKES	"A"	PISTON AREA
LS	...D	10mm - 35mm	37,0(1.46")	PUSH 31,17 cm ² (4.83 in ²)
LE	-	5mm - 25mm	47,0(1.85")	
LH	...D	5mm - 15mm	57,0(2.25")	PULL 28,03 cm ² (4.34 in ²)

	Standard Threads	"EM" Option
"B"	G1/8 PORT	1/8-27
"C"	M12X1,75	1/2-13

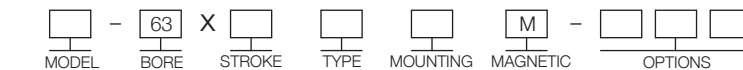
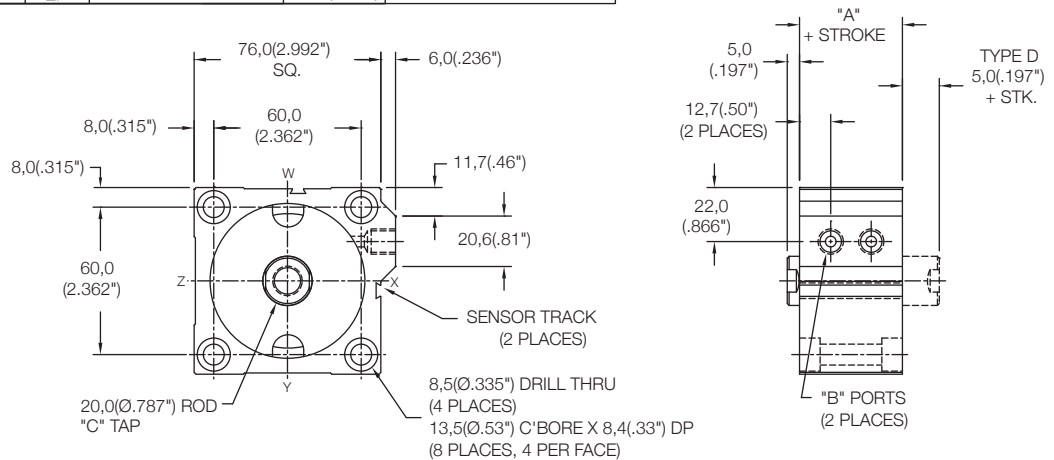

- MODEL: LS, LE, LH
- BORE: 63
- STROKE: 5mm - 100mm (SEE STROKE RANGE)
- TYPE: BLANK - NO CODE, DOUBLE ACTING, SINGLE ROD; D - DOUBLE ACTING, DOUBLE ROD
- MOUNTING: MT - THRU MOUNT; MF - FRONT MOUNT; MR - REAR MOUNT; MB - BOTH END MOUNTS; FF - FRONT FLANGE; FR - REAR FLANGE (FOR FLANGES SEE PAGE 92); PR - REAR PIVOT; PL - LONG PIVOT (FOR PIVOTS SEE PAGE 94)

SENSORS SOLD SEPARATELY
SKS, SKP, SCS, SCP - SOLID STATE
LIMIT SENSORS (SEE PAGE 88)

- EM - INCH THREADS & PORT OPTIONS
- HS - HIGH TEMPERATURE SEALS OPTION: AVAILABLE ON LE AND LH MODELS ONLY (SEE PAGE 97)
- PE - PORT ENLARGEMENT (AVAILABLE W/ "EM" OPTION ONLY = 1/4-18 NPT PORTS)
- RE - ROD EYE (SEE PAGE 96)
- RS - MALE STUD FOR ROD END (SEE PAGE 96)
- RF, RH, RN, RT, RV, RY - ROD EXTENSIONS (SEE PAGE 96)
- SH - HYDRAULIC OPTION (35 BAR 500 PSI) (SEE PAGE 97)
- UB, UF, UR - URETHANE SHOCK PAD OPTION (SEE PAGE 97)

Magnetic Side Mount Cylinder "MS"

MODEL	TYPE	STANDARD STROKES	"A"	PISTON AREA
LS	...D	10mm - 15mm	37,0(1.46")	PUSH 31,17 cm ² (4.83 in ²)
LE	...	5mm	47,0(1.85")	PULL 28,03 cm ² (4.34 in ²)

	Standard Threads	"EM" Option
"B"	G1/8 PORT	1/8-27
"C"	M12X1,75	1/2-13
"D"	M8X1,25	5/16-18

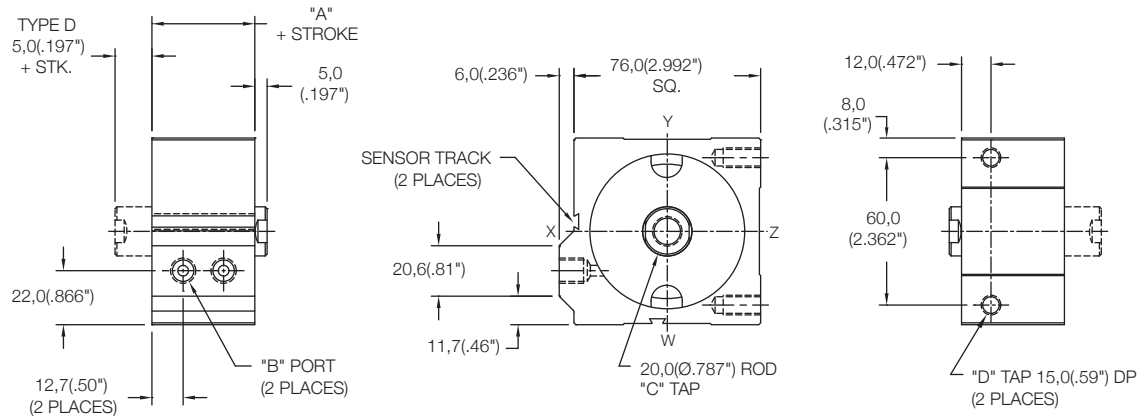

Magnetic Side Mount Cylinder "MS"

MODEL	TYPE	STANDARD STROKES	"A"	PISTON AREA
LS	...D	20mm - 100mm	37,0(1.46")	PUSH 31,17 cm ² (4.83 in ²)
LE	...	10mm - 100mm	47,0(1.85")	PULL 28,03 cm ² (4.34 in ²)
LH	...D	5mm - 100mm	57,0(2.25")	PULL 28,03 cm ² (4.34 in ²)

	Standard Threads	"EM" Option
"B"	G1/8 PORT	1/8-27
"C"	M12X1,75	1/2-13
"D"	M8X1,25	5/16-18

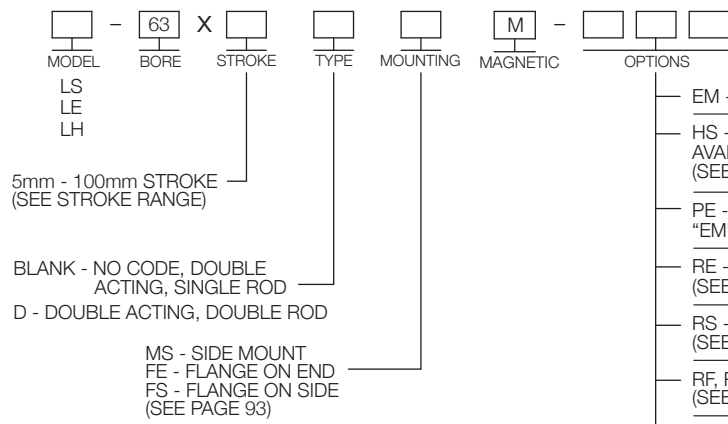
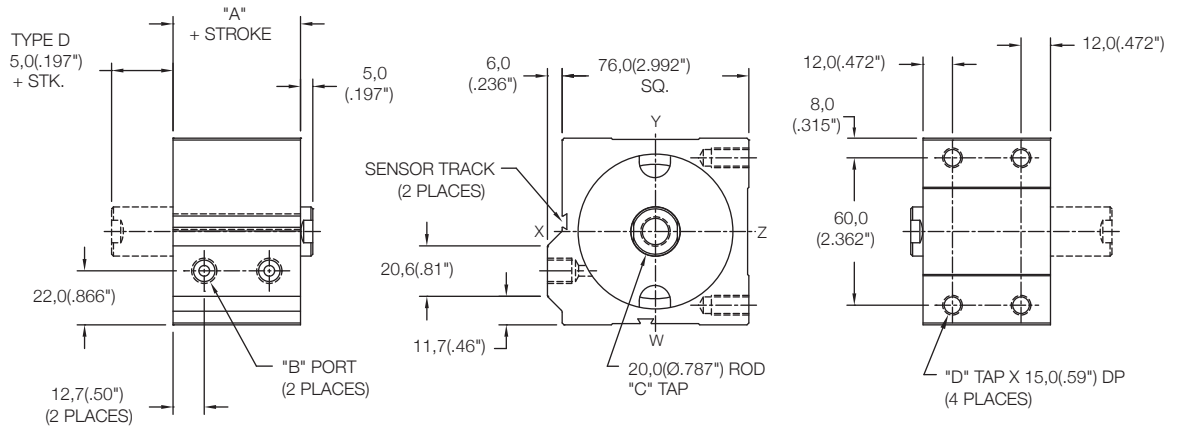

SENSORS SOLD SEPARATELY
SKS, SKP, SCS, SCP - SOLID STATE
LIMIT SENSORS (SEE PAGE 88)

- EM - INCH THREADS & PORT OPTIONS
- HS - HIGH TEMPERATURE SEALS OPTION: AVAILABLE ON LE AND LH MODELS ONLY (SEE PAGE 97)
- PE - PORT ENLARGEMENT (AVAILABLE W/ "EM" OPTION ONLY = 1/4-18 NPT PORTS)
- RE - ROD EYE (SEE PAGE 96)
- RS - MALE STUD FOR ROD END (SEE PAGE 96)
- RF, RH, RN, RT, RV, RY - ROD EXTENSIONS (SEE PAGE 96)
- SH - HYDRAULIC OPTION (35 BAR 500 PSI) (SEE PAGE 97)
- UB, UF, UR - URETHANE SHOCK PAD OPTION (SEE PAGE 97)

Non Magnetic Side Mount Cylinder "MS"

MODEL	TYPE	STANDARD STROKES	"A"	PISTON AREA
LS	_,D	10mm - 20mm	32,0(1.26")	PUSH 31,17 cm ² (4.83 in ²)
LE	-	5mm - 10mm	42,0(1.66")	PULL 28,03 cm ² (4.34 in ²)

	Standard Threads	"EM" Option
"B"	G1/8 PORT	1/8-27
"C"	M12X1,75	1/2-13
"D"	M8X1,25	5/16-18

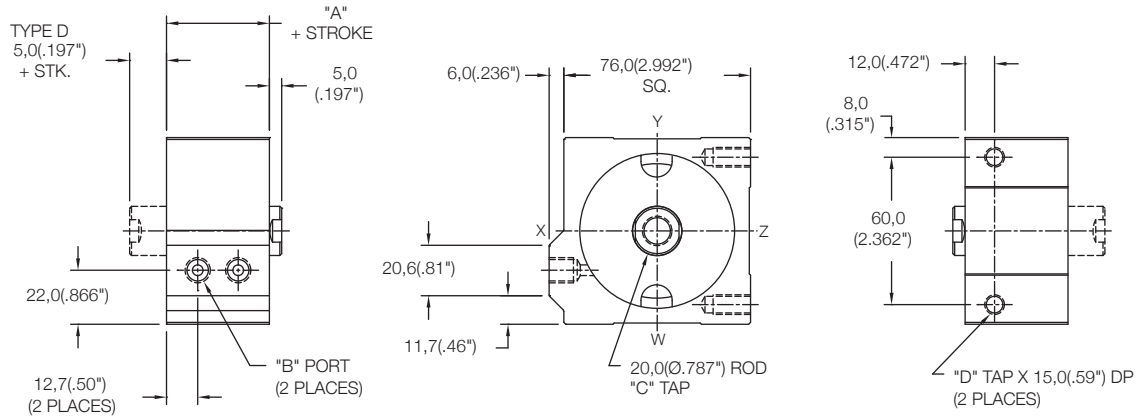

Non Magnetic Side Mount Cylinder "MS"

MODEL	TYPE	STANDARD STROKES	"A"	PISTON AREA
LS	_,D	25mm - 100mm	32,0(1.26")	PUSH 31,17 cm ² (4.83 in ²)
LE	-	15mm - 100mm	42,0(1.66")	PULL 28,03 cm ² (4.34 in ²)
LH	_,D	5mm - 100mm	52,0(2.05")	PULL 28,03 cm ² (4.34 in ²)

	Standard Threads	"EM" Option
"B"	G1/8 PORT	1/8-27
"C"	M12X1,75	1/2-13
"D"	M8X1,25	5/16-18

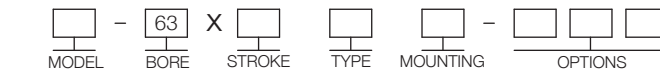
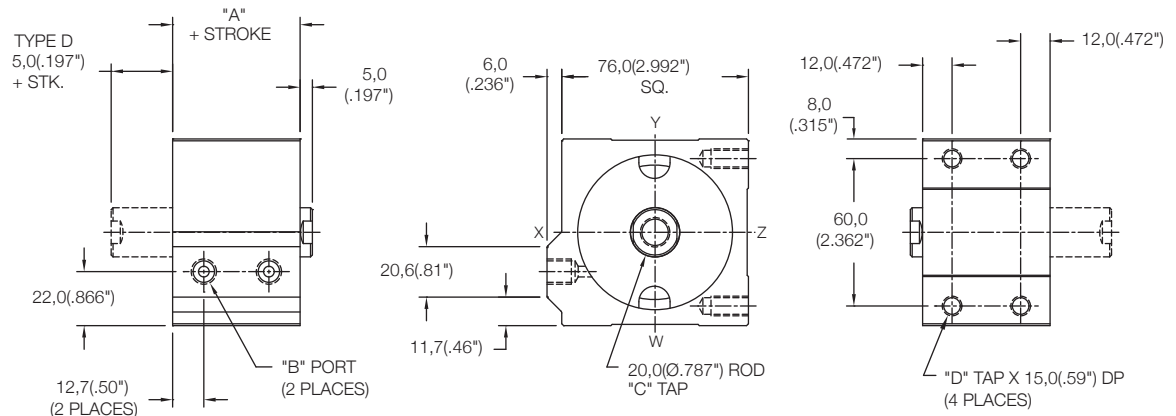

LS
LE
LH

5mm - 100mm STROKE
(SEE STROKE RANGE)

BLANK - NO CODE, DOUBLE ACTING, SINGLE ROD
D - DOUBLE ACTING, DOUBLE ROD

MS - SIDE MOUNT
FE - FLANGE ON END
FS - FLANGE ON SIDE
(SEE PAGE 93)

EM - INCH THREADS & PORT OPTIONS

HS - HIGH TEMPERATURE SEALS OPTION:
AVAILABLE ON LE AND LH MODELS ONLY
(SEE PAGE 97)

PE - PORT ENLARGEMENT (AVAILABLE W/
"EM" OPTION ONLY = 1/4-18 NPT PORTS)

RE - ROD EYE
(SEE PAGE 96)

RS - MALE STUD FOR ROD END
(SEE PAGE 96)

RF, RH, RN, RT, RV, RY - ROD EXTENSIONS
(SEE PAGE 96)

SH - HYDRAULIC OPTION (35 BAR 500 PSI)
(SEE PAGE 97)

UB, UF, UR - URETHANE SHOCK PAD OPTION
(SEE PAGE 97)

Non Magnetic Front Mount Cylinder "MF"

MODEL	TYPE	STANDARD STROKES	"A"	PISTON AREA
LS	...D	10mm - 100mm	38,0(1.50")	PUSH 45,6 cm ² (7.07 in ²)
LE	-	5mm - 100mm	48,0(1.89")	PULL 42,46 cm ² (6.59 in ²)
LH	...D	5mm - 100mm	58,0(2.28")	PULL 42,46 cm ² (6.59 in ²)

	Standard Threads	"EM" Option
"B"	G1/8 PORT	1/8-27
"C"	M12X1,75	1/2-13
"D"	M10X1,5	3/8-24

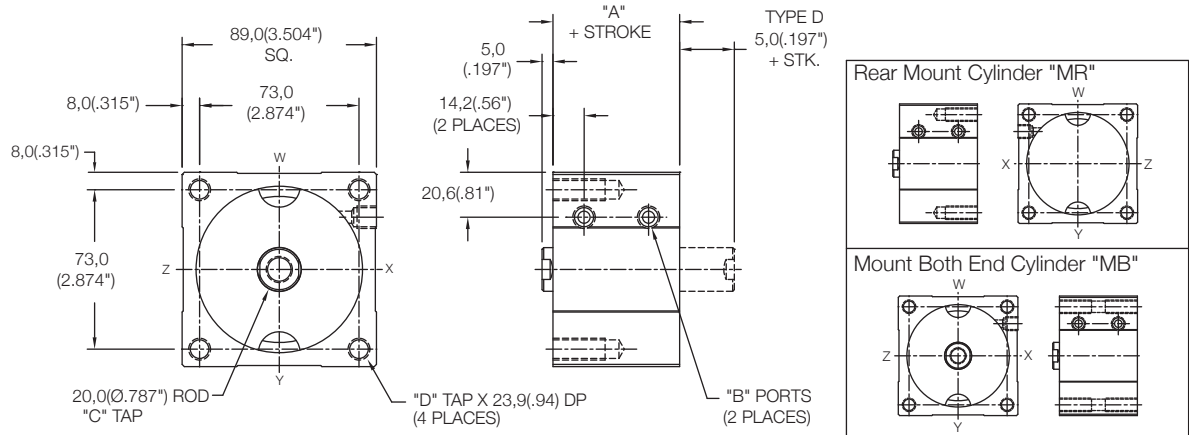

Non Magnetic Thru Mount Cylinder "MT"

MODEL	TYPE	STANDARD STROKES	"A"	PISTON AREA
LS	...D	10mm - 40mm	38,0(1.50")	PUSH 45,6 cm ² (7.07 in ²)
LE	-	5mm - 30mm	48,0(1.89")	PULL 42,46 cm ² (6.59 in ²)
LH	...D	5mm - 20mm	58,0(2.28")	PULL 42,46 cm ² (6.59 in ²)

	Standard Threads	"EM" Option
"B"	G1/8 PORT	1/8-27
"C"	M12X1,75	1/2-13

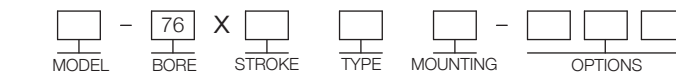
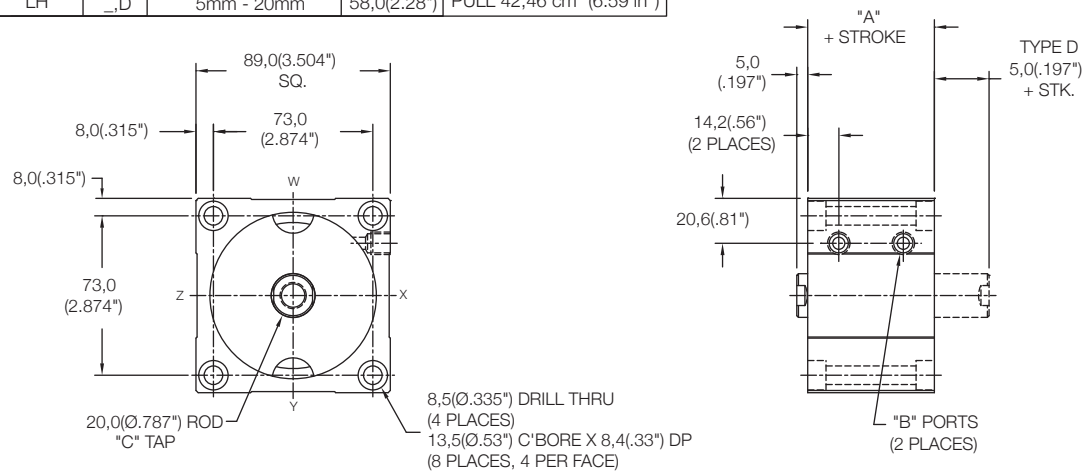

MODEL
LS
LE
LH

5mm - 100mm STROKE
(SEE STROKE RANGE)

BLANK - NO CODE, DOUBLE ACTING, SINGLE ROD
D - DOUBLE ACTING, DOUBLE ROD

MT - THRU MOUNT
MF - FRONT MOUNT
MR - REAR MOUNT
MB - BOTH END MOUNTS
FF - FRONT FLANGE
FR - REAR FLANGE
(FOR FLANGES SEE PAGE 92)

PR - REAR PIVOT
PL - LONG PIVOT
(FOR PIVOTS SEE PAGE 94)

- EM - INCH THREADS & PORT OPTIONS
- HS - HIGH TEMPERATURE SEALS OPTION: AVAILABLE ON LE AND LH MODELS ONLY (SEE PAGE 97)
- PE - PORT ENLARGEMENT (AVAILABLE W/ "EM" OPTION ONLY = 1/4-18 NPT PORTS)
- RE - ROD EYE (SEE PAGE 96)
- RS - MALE STUD FOR ROD END (SEE PAGE 96)
- RF, RH, RN, RT, RV, RY - ROD EXTENSIONS (SEE PAGE 96)
- SH - HYDRAULIC OPTION (35 BAR 500 PSI) (SEE PAGE 97)
- UB, UF, UR - URETHANE SHOCK PAD OPTION (SEE PAGE 97)

Magnetic Front Mount Cylinder "MF"

MODEL	TYPE	STANDARD STROKES	"A"	PISTON AREA
LS	_,D	10mm - 100mm	43,0(1.69")	PUSH 45,6 cm ² (7.07 in ²)
LE	-	5mm - 100mm	53,0(2.09")	PULL 42,46 cm ² (6.59 in ²)
LH	_,D	5mm - 100mm	63,0(2.48")	PULL 42,46 cm ² (6.59 in ²)

	Standard Threads	"EM" Option
"B"	G1/8 PORT	1/8-27
"C"	M12X1,75	1/2-13
"D"	M10X1,5	3/8-24

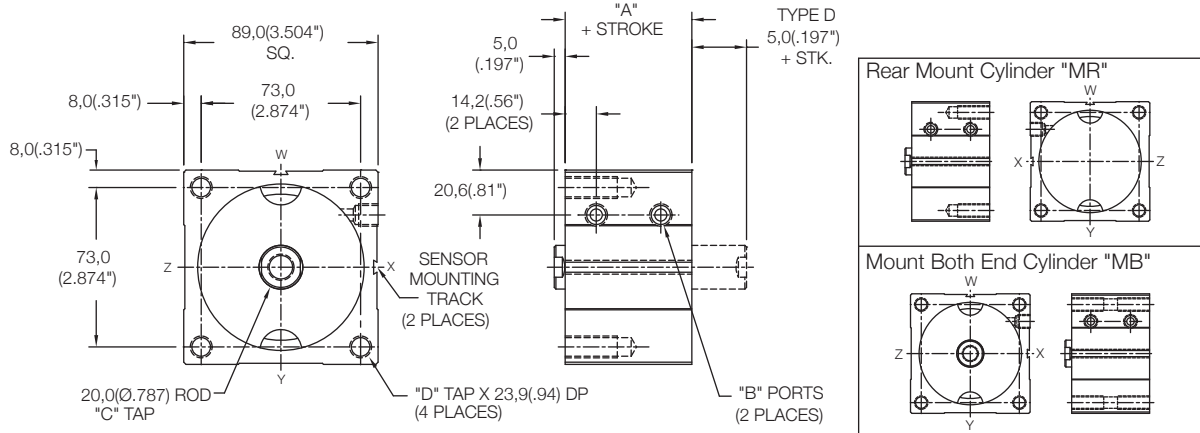

Magnetic Thru Mount Cylinder "MT"

MODEL	TYPE	STANDARD STROKES	"A"	PISTON AREA
LS	_,D	10mm - 35mm	43,0(1.69")	PUSH 45,6 cm ² (7.07 in ²)
LE	-	5mm - 25mm	53,0(2.09")	PULL 42,46 cm ² (6.59 in ²)
LH	_,D	5mm - 15mm	63,0(2.48")	PULL 42,46 cm ² (6.59 in ²)

	Standard Threads	"EM" Option
"B"	G1/8 PORT	1/8-27
"C"	M12X1,75	1/2-13

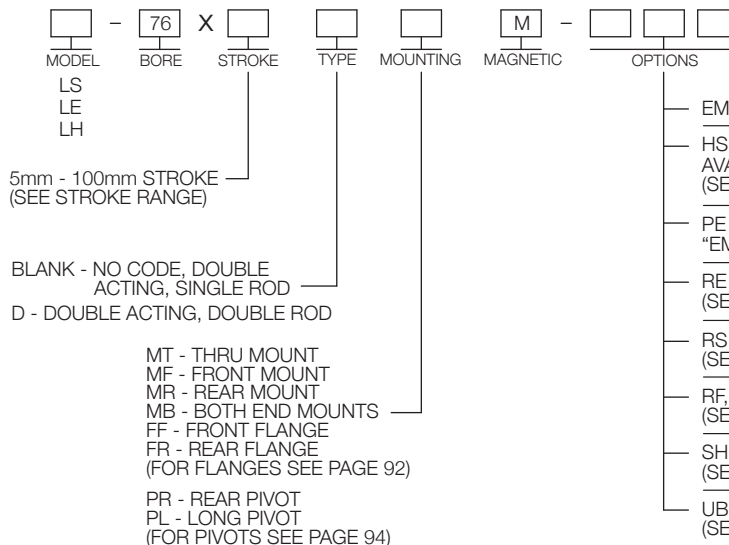
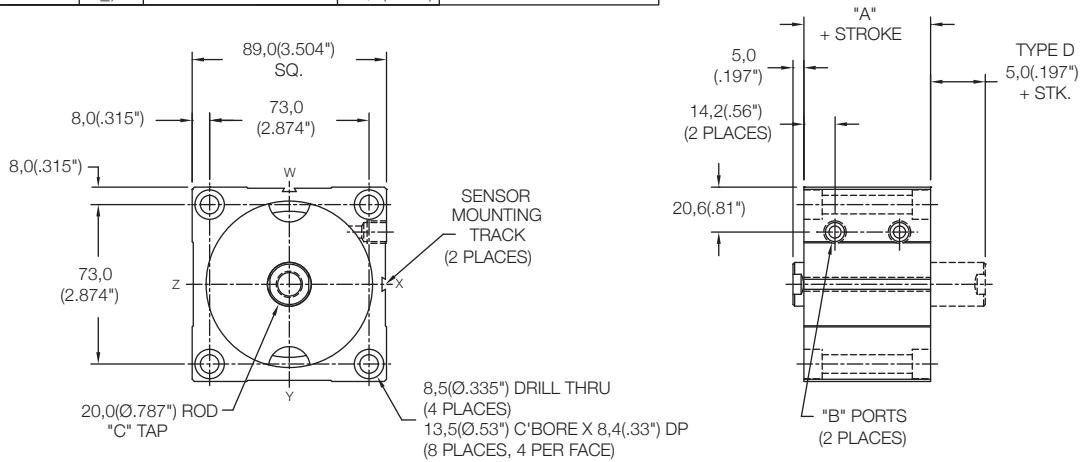

SENSORS SOLD SEPARATELY
SKS, SKP, SCS, SCP - SOLID STATE
LIMIT SENSORS (SEE PAGE 88)

Magnetic Side Mount Cylinder "MS"

MODEL	TYPE	STANDARD STROKES	"A"	PISTON AREA
LS	...D	10mm - 15mm	43,0(1.69")	PUSH 45,6 cm ² (7.07 in ²)
LE	-	5mm	53,0(2.09")	PULL 42,46 cm ² (6.59 in ²)

	Standard Threads	"EM" Option
"B"	G1/8 PORT	1/8-27
"C"	M12X1,75	1/2-13
"D"	M10X1,5	3/8-24

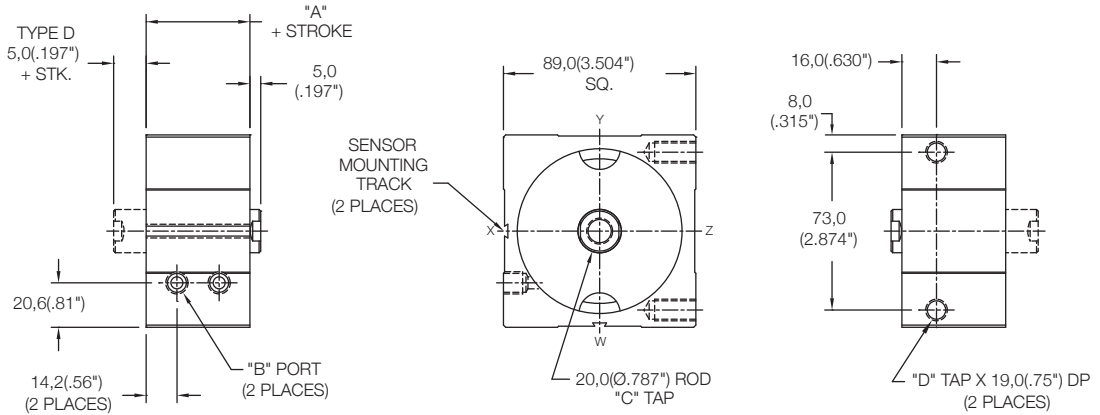

Magnetic Side Mount Cylinder "MS"

MODEL	TYPE	STANDARD STROKES	"A"	PISTON AREA
LS	...D	20mm - 100mm	43,0(1.69")	PUSH 45,6 cm ² (7.07 in ²)
LE	-	10mm - 100mm	53,0(2.09")	PULL 42,46 cm ² (6.59 in ²)
LH	...D	5mm - 100mm	63,0(2.48")	PULL 42,46 cm ² (6.59 in ²)

	Standard Threads	"EM" Option
"B"	G1/8 PORT	1/8-27
"C"	M12X1,75	1/2-13
"D"	M10X1,5	3/8-24

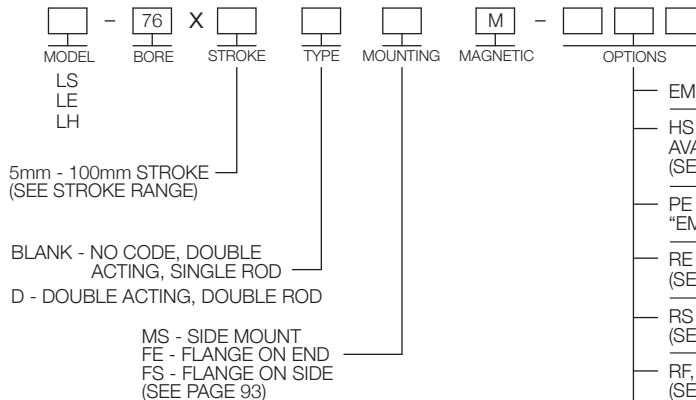
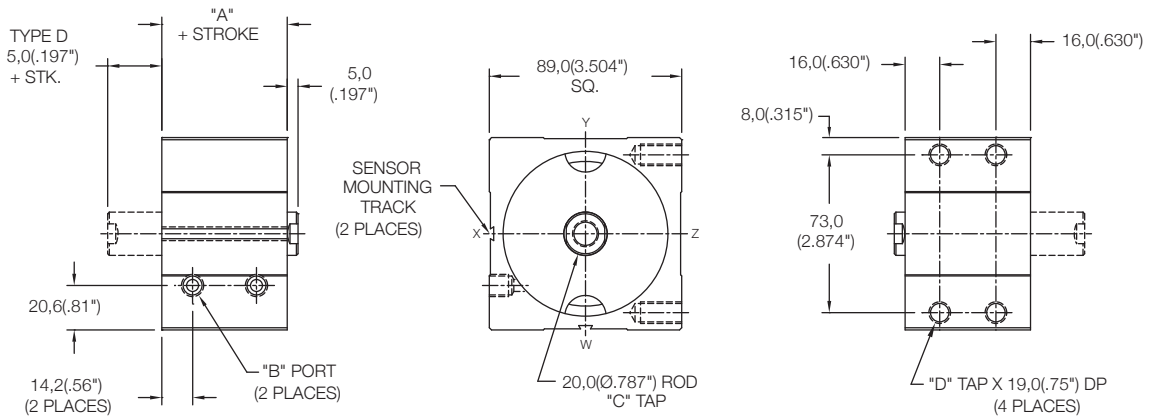

SENSORS SOLD SEPARATELY
SKS, SKP, SCS, SCP - SOLID STATE
LIMIT SENSORS (SEE PAGE 88)

Non Magnetic Side Mount Cylinder "MS"

MODEL	TYPE	STANDARD STROKES	"A"	PISTON AREA
LS	_,D	10mm - 20mm	38,0(1.50")	PUSH 45,6 cm ² (7.07 in ²)
LE	-	5mm - 10mm	48,0(1.89")	PULL 42,46 cm ² (6.59 in ²)

	Standard Threads	"EM" Option
"B"	G1/8 PORT	1/8-27
"C"	M12X1,75	1/2-13
"D"	M10X1,5	3/8-24

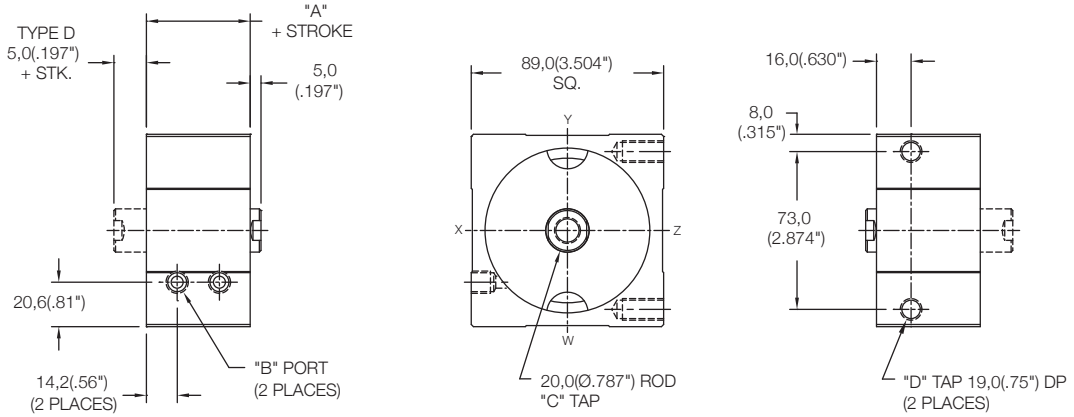

Non Magnetic Side Mount Cylinder "MS"

MODEL	TYPE	STANDARD STROKES	"A"	PISTON AREA
LS	_,D	25mm - 100mm	38,0(1.50")	PUSH 45,6 cm ² (7.07 in ²)
LE	-	15mm - 100mm	48,0(1.89")	PULL 42,46 cm ² (6.59 in ²)
LH	_,D	5mm - 100mm	58,0(2.28")	PULL 42,46 cm ² (6.59 in ²)

	Standard Threads	"EM" Option
"B"	G1/8 PORT	1/8-27
"C"	M12X1,75	1/2-13
"D"	M10X1,5	3/8-24

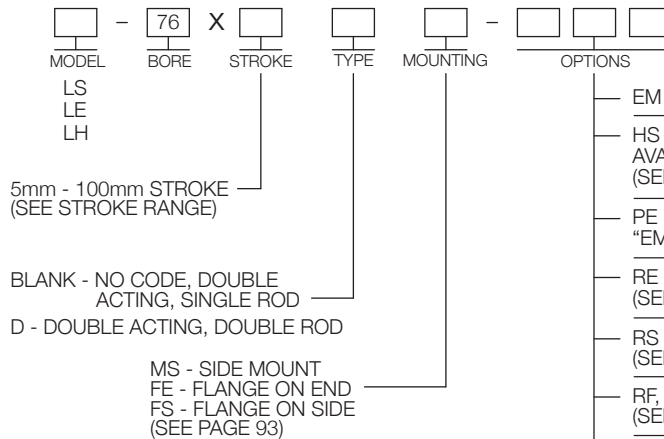
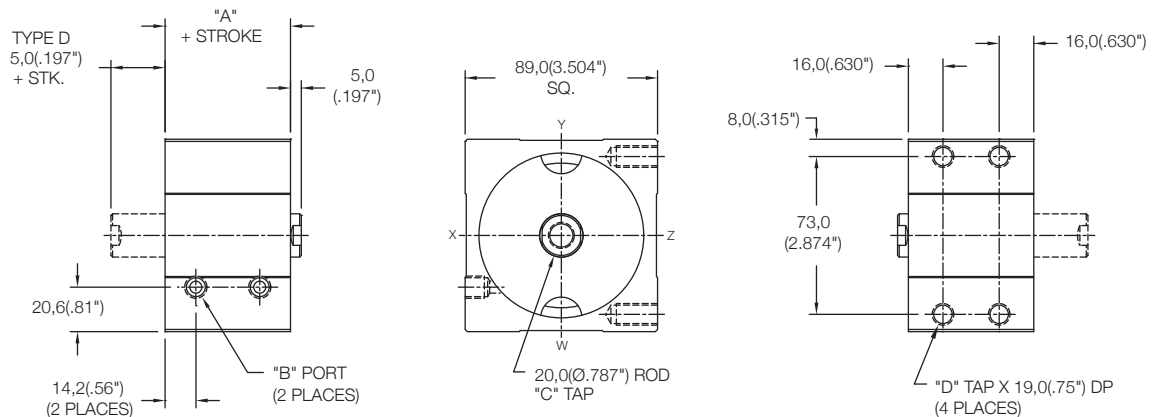

Non Magnetic Front Mount Cylinder "MF"

MODEL	TYPE	STANDARD STROKES	"A"	PISTON AREA
LS	...D	10mm - 100mm	41,5(1.63")	PUSH 81,07 cm ² (12.57 in ²)
LE	...	5mm - 100mm	51,5(2.03")	
LH	...D	5mm - 100mm	61,5(2.42")	PULL 77,93 cm ² (12.09 in ²)

	Standard Threads	"EM" Option
"B"	G1/8 PORT	1/8-27
"C"	M12X1,75	1/2-13
"D"	M8X1,25	5/16-18

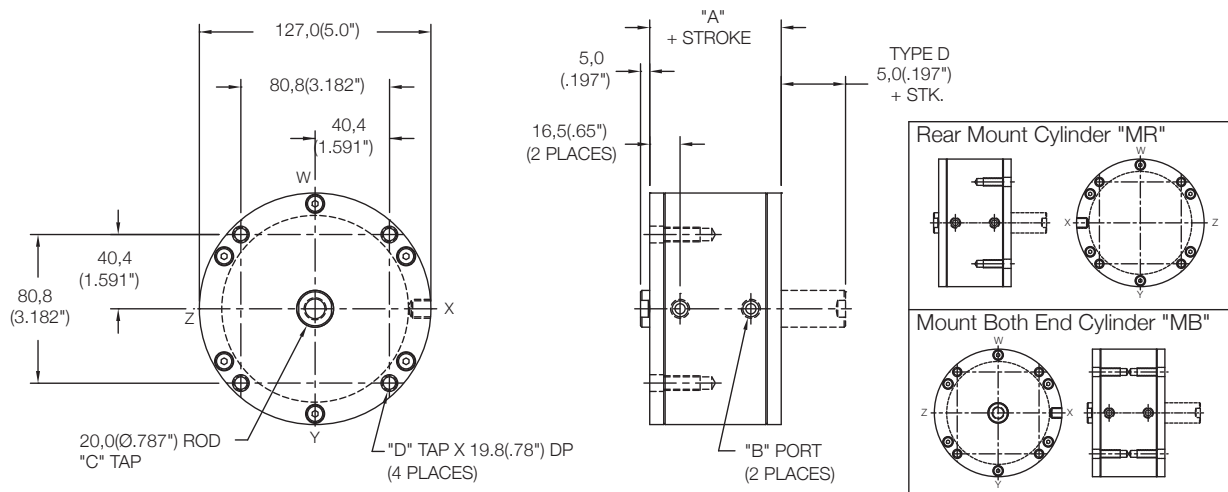

Non Magnetic Thru Mount Cylinder "MT"

MODEL	TYPE	STANDARD STROKES	"A"	PISTON AREA
LS	...D	10mm - 50mm	41,5(1.63")	PUSH 81,07 cm ² (12.57 in ²)
LE	...	5mm - 40mm	51,5(2.03")	
LH	...D	5mm - 30mm	61,5(2.42")	PULL 77,93 cm ² (12.09 in ²)

	Standard Threads	"EM" Option
"B"	G1/8 PORT	1/8-27
"C"	M12X1,75	1/2-13

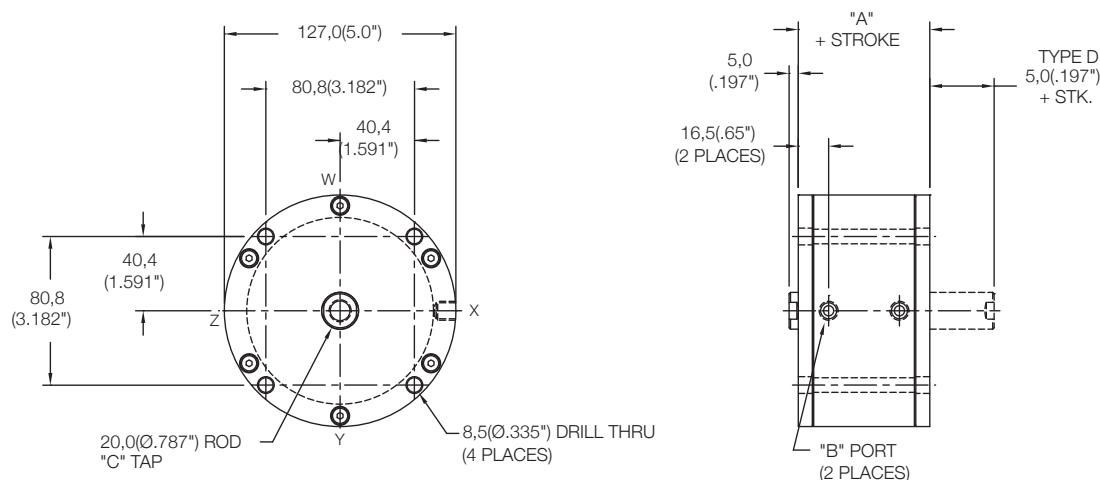

<div style="border: 1px solid black; width: 20px; height: 20px; margin: 0 auto;"></div> MODEL LS LE LH 5mm - 100mm STROKE (SEE STROKE RANGE) BLANK - NO CODE, DOUBLE ACTING, SINGLE ROD D - DOUBLE ACTING, DOUBLE ROD MT - THRU MOUNT MF - FRONT MOUNT MR - REAR MOUNT MB - BOTH END MOUNTS FF - FRONT FLANGE FR - REAR FLANGE (FOR FLANGES SEE PAGE 92)	- 101 X BORE STROKE	<div style="border: 1px solid black; width: 20px; height: 20px; margin: 0 auto;"></div> TYPE MOUNTING	<div style="border: 1px solid black; width: 20px; height: 20px; margin: 0 auto;"></div> - <div style="border: 1px solid black; width: 20px; height: 20px; margin: 0 auto;"></div> OPTIONS	EM - INCH THREADS & PORT OPTIONS HS - HIGH TEMPERATURE SEALS OPTION: AVAILABLE ON LE AND LH MODELS ONLY (SEE PAGE 97) PE - PORT ENLARGEMENT (AVAILABLE W/ "EM" OPTION ONLY = 1/4-18 NPT PORTS) RE - ROD EYE (SEE PAGE 96) RS - MALE STUD FOR ROD END (SEE PAGE 96) RF, RH, RN, RT, RV, RY - ROD EXTENSIONS (SEE PAGE 96)
---	------------------------	--	---	---

Magnetic Front Mount Cylinder "MF"

MODEL	TYPE	STANDARD STROKES	"A"	PISTON AREA
LS	_,D	10mm - 100mm	51,5(2.03")	PUSH 81,07 cm ² (12.57 in ²)
LE	_	5mm - 100mm	61,5(2.42")	
LH	_,D	5mm - 100mm	71,5(2.82")	PULL 77,93 cm ² (12.09 in ²)

	Standard Threads	"EM" Option
"B"	G1/8 PORT	1/8-27
"C"	M12X1,75	1/2-13
"D"	M8X1,25	5/16-18

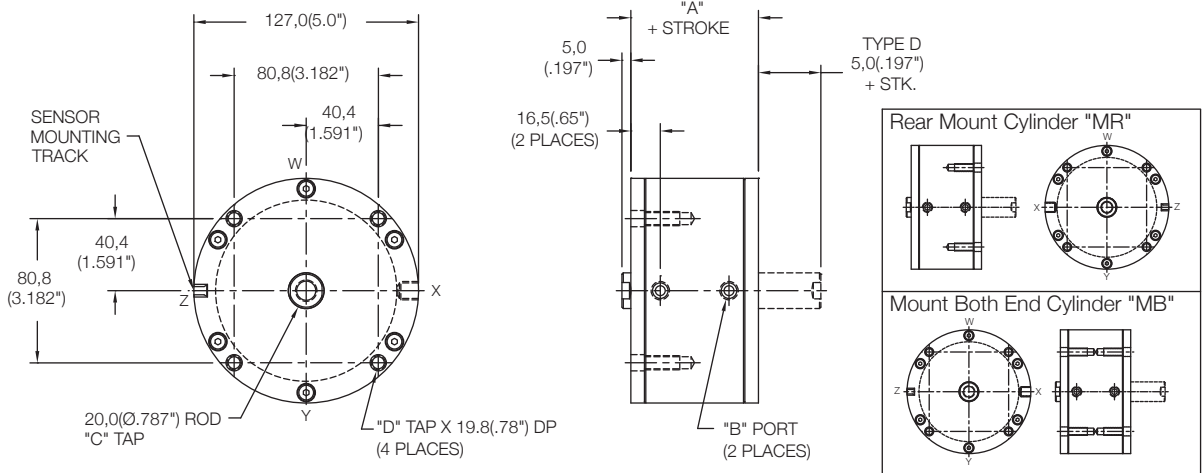

Magnetic Thru Mount Cylinder "MT"

MODEL	TYPE	STANDARD STROKES	"A"	PISTON AREA
LS	_,D	10mm - 40mm	51,5(2.03")	PUSH 81,07 cm ² (12.57 in ²)
LE	_	5mm - 30mm	61,5(2.42")	
LH	_,D	5mm - 20mm	71,5(2.82")	PULL 77,93 cm ² (12.09 in ²)

	Standard Threads	"EM" Option
"B"	G1/8 PORT	1/8-27
"C"	M12X1,75	1/2-13

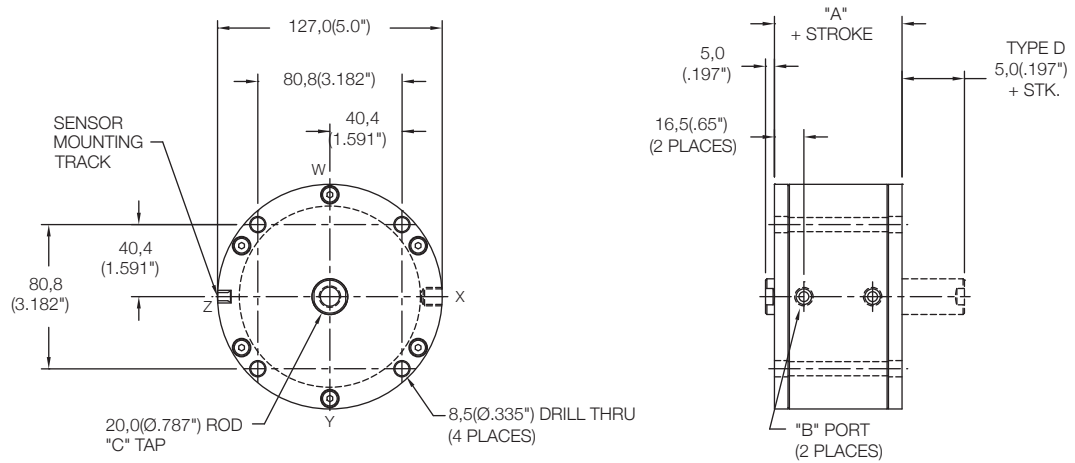

<p>MODEL: LS, LE, LH</p> <p>BORE: 101</p> <p>STROKE: X</p> <p>TYPE: BLANK - NO CODE, DOUBLE ACTING, SINGLE ROD; D - DOUBLE ACTING, DOUBLE ROD</p> <p>MOUNTING: MT - THRU MOUNT; MF - FRONT MOUNT; MR - REAR MOUNT; MB - BOTH END MOUNTS; FF - FRONT FLANGE; FR - REAR FLANGE (FOR FLANGES SEE PAGE 92)</p>	<p>MAGNETIC: M</p> <p>OPTIONS: EM - INCH THREADS & PORT OPTIONS; HS - HIGH TEMPERATURE SEALS OPTION: AVAILABLE ON LE AND LH MODELS ONLY (SEE PAGE 97); PE - PORT ENLARGEMENT (AVAILABLE W/ "EM" OPTION ONLY = 1/4-18 NPT PORTS); RE - ROD EYE (SEE PAGE 96); RS - MALE STUD FOR ROD END (SEE PAGE 96); RF, RH, RN, RT, RV, RY - ROD EXTENSIONS (SEE PAGE 96)</p>	<p>SENSORS SOLD SEPARATELY SKS, SKP, SCS, SCP - SOLID STATE LIMIT SENSORS (SEE PAGE 88)</p>
--	--	---

Non Magnetic Front Mount Cylinder "MF"

MODEL	TYPE	STANDARD STROKES	"A"	PISTON AREA
LS	...D	10mm - 100mm	44,5(1.75")	PUSH 126,7 cm ² (19.6 in ²)
LE	...	5mm - 100mm	54,5(2.15")	
LH	...D	5mm - 100mm	64,5(2.54")	PULL 123,5 cm ² (19.1 in ²)

	Standard Threads	"EM" Option
"B"	G1/8 PORT	1/8-27
"C"	M12X1,75	1/2-13
"D"	M8X1,25	5/16-18

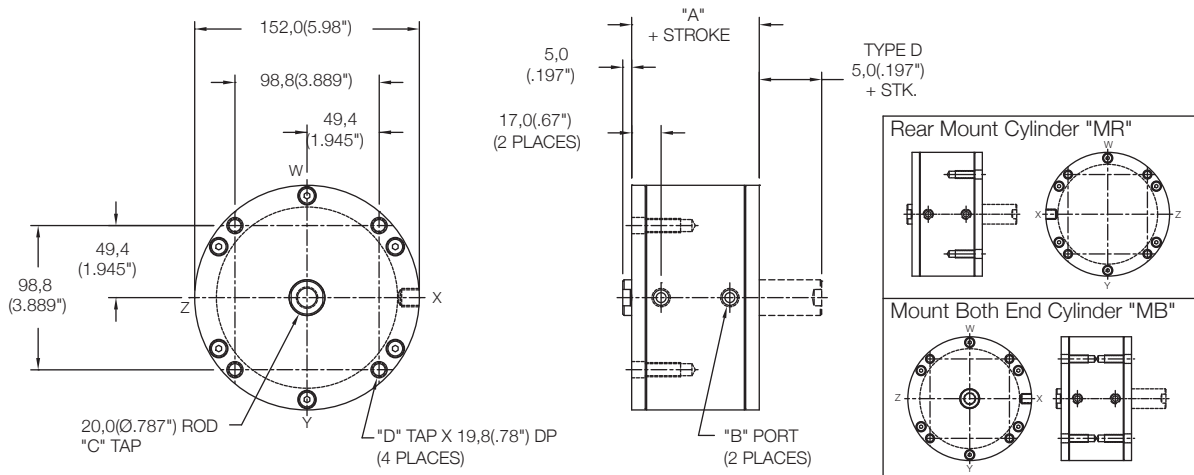

Non Magnetic Thru Mount Cylinder "MT"

MODEL	TYPE	STANDARD STROKES	"A"	PISTON AREA
LS	...D	10mm - 45mm	44,5(1.75")	PUSH 126,7 cm ² (19.6 in ²)
LE	...	5mm - 35mm	54,5(2.15")	
LH	...D	5mm - 25mm	64,5(2.54")	PULL 123,5 cm ² (19.1 in ²)

	Standard Threads	"EM" Option
"B"	G1/8 PORT	1/8-27
"C"	M12X1,75	1/2-13

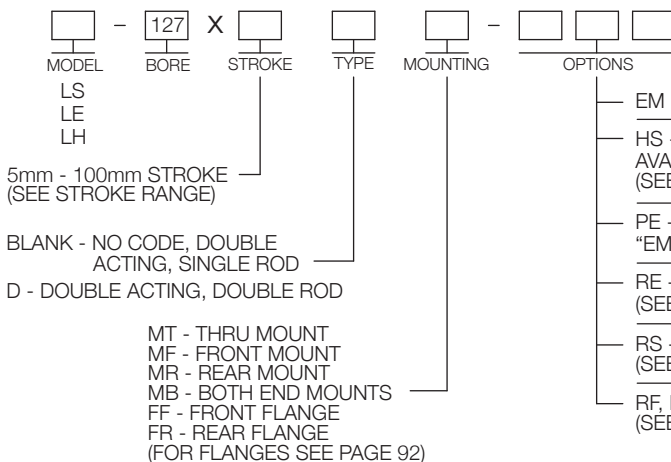
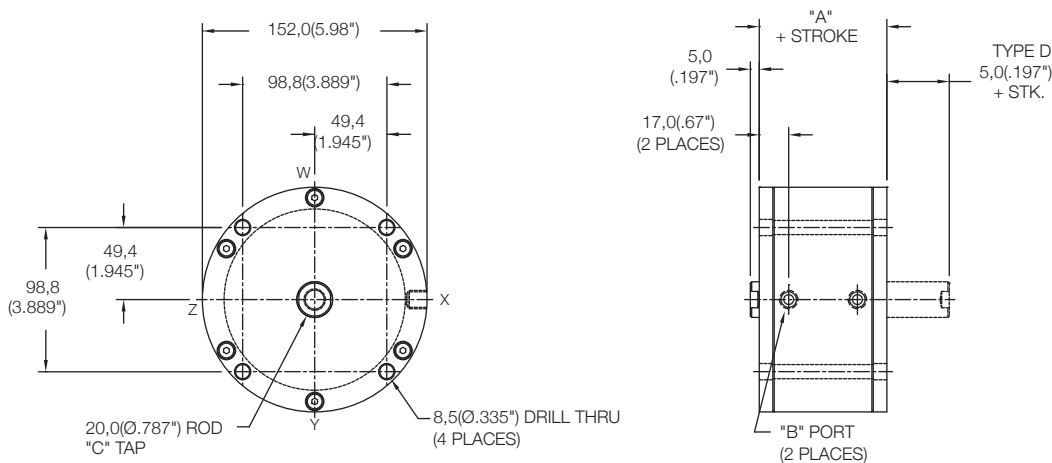

Non Magnetic Front Mount Cylinder "MF"

MODEL	TYPE	STANDARD STROKES	"A"	PISTON AREA
LS	...D	10mm - 100mm	51,0(2.00")	PUSH 181,46 cm ² (28.2 in ²) PULL 176,55 cm ² (27.45 in ²)

	Standard Threads	"EM" Option
"B"	G1/8 PORT	1/8-27
"C"	M16X2,0	5/8-18
"D"	M8X1,25	5/16-18

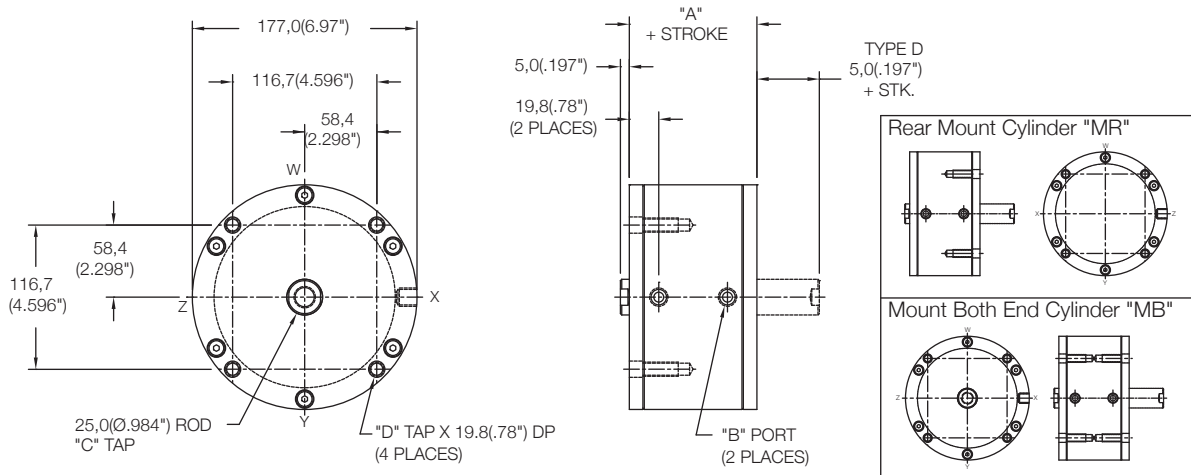

Non Magnetic Thru Mount Cylinder "MT"

MODEL	TYPE	STANDARD STROKES	"A"	PISTON AREA
LS	...D	10mm - 40mm	51,0(2.00")	PUSH 181,46 cm ² (28.2 in ²) PULL 176,55 cm ² (27.45 in ²)

	Standard Threads	"EM" Option
"B"	G1/8 PORT	1/8-27
"C"	M16X2,0	5/8-18

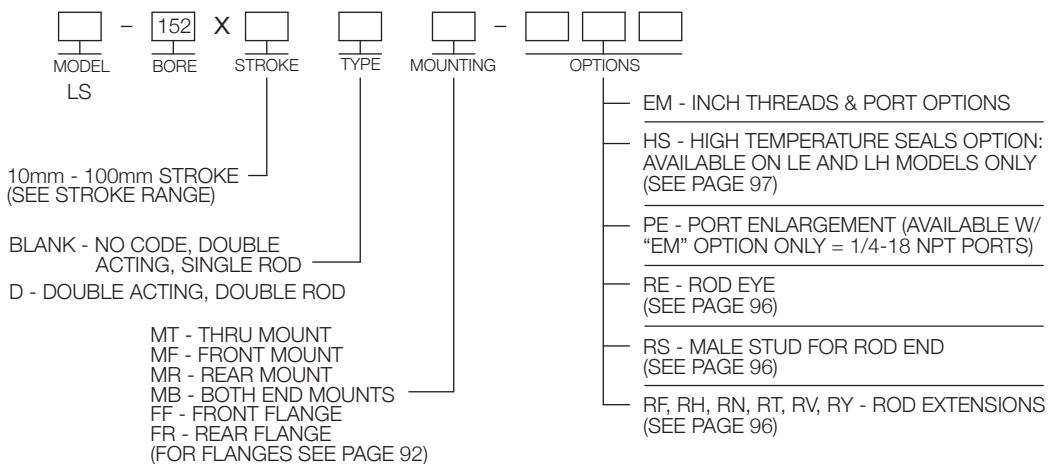
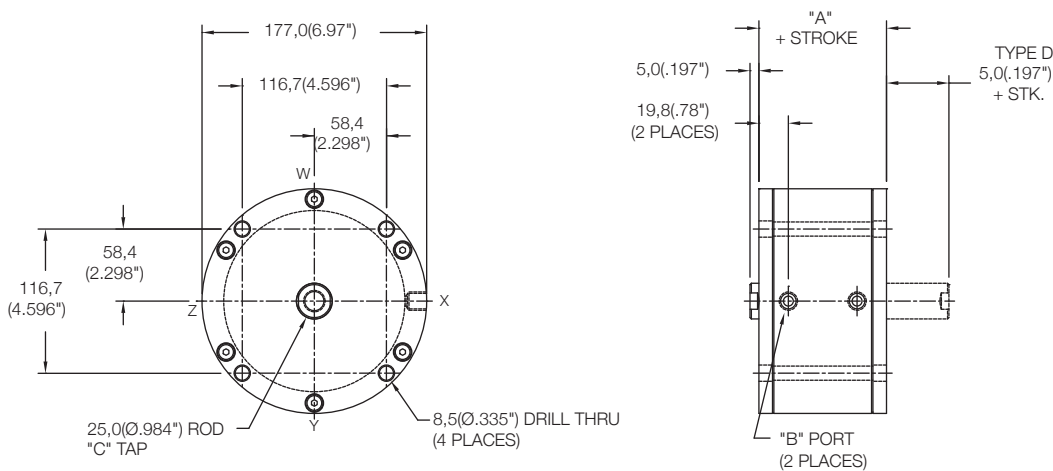

Magnetic Front Mount Cylinder "MF"

MODEL	TYPE	STANDARD STROKES	"A"	PISTON AREA
LS	_D	10mm - 100mm	61,0(2.40")	PUSH 181,46 cm ² (28.2 in ²) PULL 176,55 cm ² (27.45 in ²)

	Standard Threads	"EM" Option
"B"	G1/8 PORT	1/8-27
"C"	M16X2,0	5/8-18
"D"	M8X1,25	5/16-18

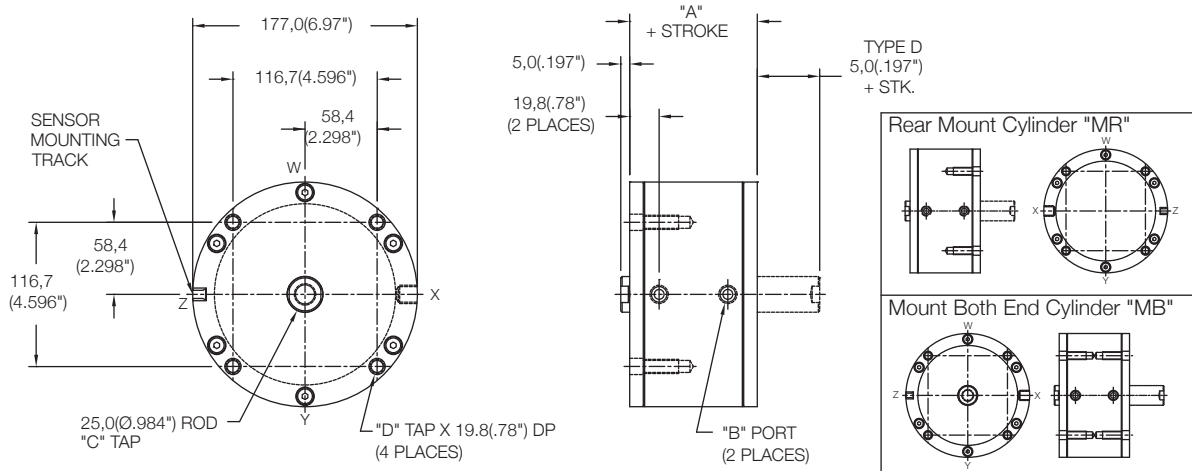

Magnetic Thru Mount Cylinder "MT"

MODEL	TYPE	STANDARD STROKES	"A"	PISTON AREA
LS	_D	10mm - 30mm	61,0(2.40")	PUSH 181,46 cm ² (28.2 in ²) PULL 176,55 cm ² (27.45 in ²)

	Standard Threads	"EM" Option
"B"	G1/8 PORT	1/8-27
"C"	M16X2,0	5/8-18

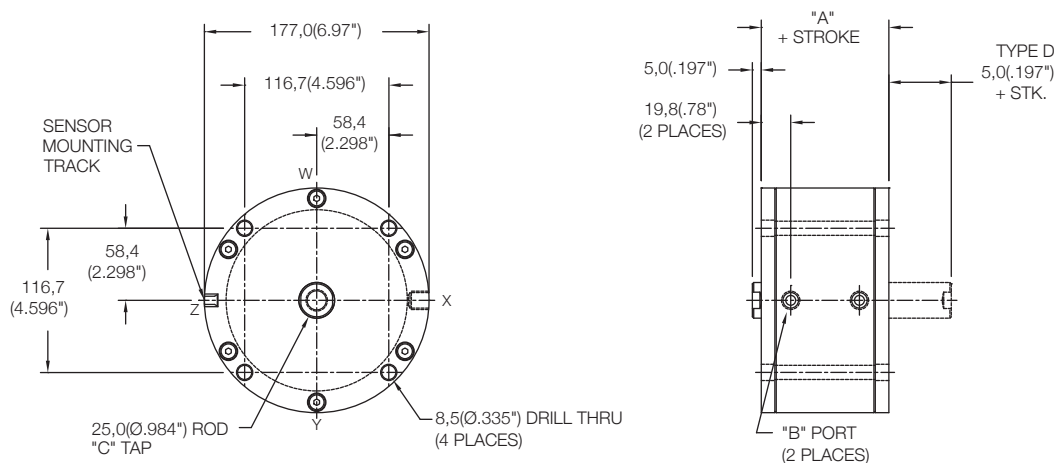

<table border="0"> <tr> <td>MODEL</td> <td>-</td> <td>152</td> <td>X</td> <td>STROKE</td> <td>TYPE</td> <td>MOUNTING</td> <td>MAGNETIC</td> <td>-</td> <td>OPTIONS</td> </tr> <tr> <td>LS</td> <td></td> <td></td> <td></td> <td></td> <td></td> <td></td> <td>M</td> <td></td> <td></td> </tr> </table>	MODEL	-	152	X	STROKE	TYPE	MOUNTING	MAGNETIC	-	OPTIONS	LS							M			<p>SENSORS SOLD SEPARATELY SKS, SKP, SCS, SCP - SOLID STATE LIMIT SENSORS (SEE PAGE 88)</p>
MODEL	-	152	X	STROKE	TYPE	MOUNTING	MAGNETIC	-	OPTIONS												
LS							M														
<p>10mm - 100mm STROKE (SEE STROKE RANGE)</p>	<p>EM - INCH THREADS & PORT OPTIONS</p>																				
<p>BLANK - NO CODE, DOUBLE ACTING, SINGLE ROD</p>	<p>HS - HIGH TEMPERATURE SEALS OPTION: AVAILABLE ON LE AND LH MODELS ONLY (SEE PAGE 97)</p>																				
<p>D - DOUBLE ACTING, DOUBLE ROD</p>	<p>PE - PORT ENLARGEMENT (AVAILABLE W/ "EM" OPTION ONLY = 1/4-18 NPT PORTS)</p>																				
<p>MT - THRU MOUNT MF - FRONT MOUNT MR - REAR MOUNT MB - BOTH END MOUNTS FF - FRONT FLANGE FR - REAR FLANGE (FOR FLANGES SEE PAGE 92)</p>	<p>RE - ROD EYE (SEE PAGE 96)</p>																				
	<p>RS - MALE STUD FOR ROD END (SEE PAGE 96)</p>																				
	<p>RF, RH, RN, RT, RV, RY - ROD EXTENSIONS (SEE PAGE 96)</p>																				

TS SERIES

PNEUMATIC CYLINDERS

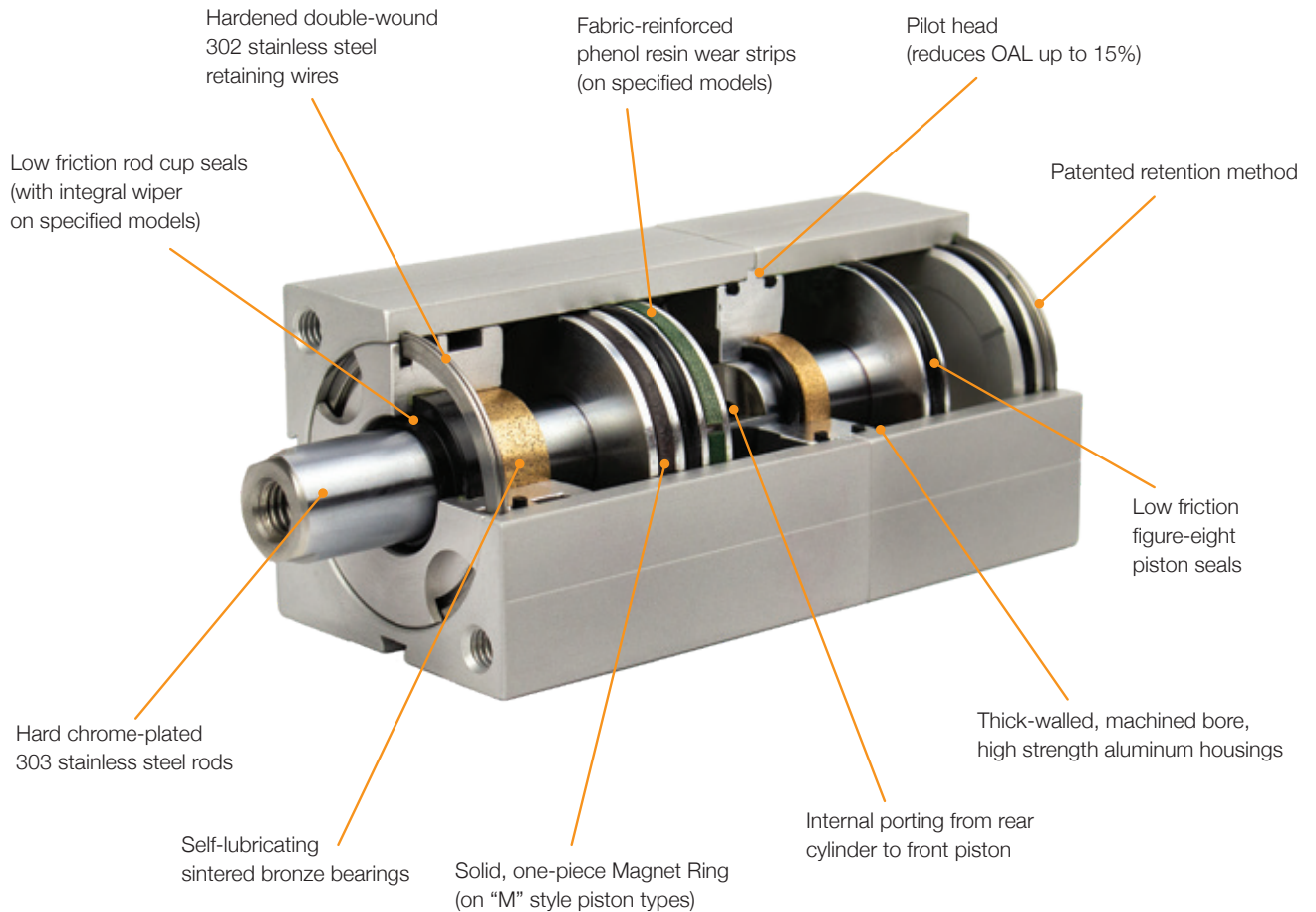

Tandem 2 Piston Pneumatic Cylinders

The T series cylinder line is based on the same rugged, proven designs of Nason's L series cylinders. Thick-walled, custom aluminum extrusions are precision bored and honed. High strength aluminum internal components are machined to exacting tolerances to control seal squeezes and stroke tolerances. Chrome-plated 303 stainless steel rods are precision ground for long life. The dual piloted head design aligns bores and rods and helps reduce overall length up to 15% compared to two standard units bolted together. Internal porting from the rear cylinder piston to the front cylinder piston simplifies plumbing.

Tandem Piston Cylinder

EXTENDING TANDEM 2 PISTON CYLINDER

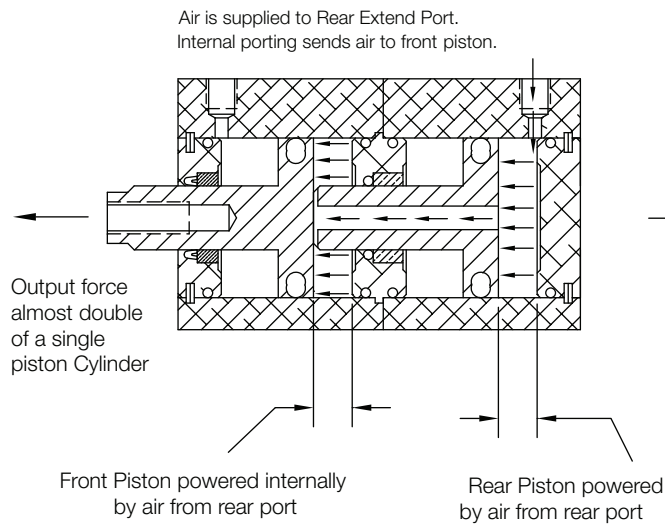

RETRACTING TANDEM 2 PISTON CYLINDER

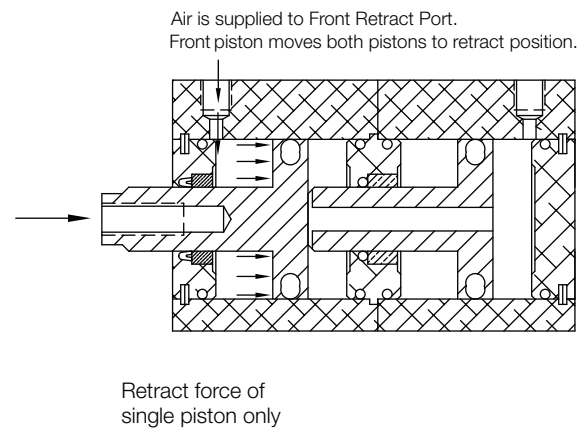

Individual Features

Model - TS

- Most compact of 3 models

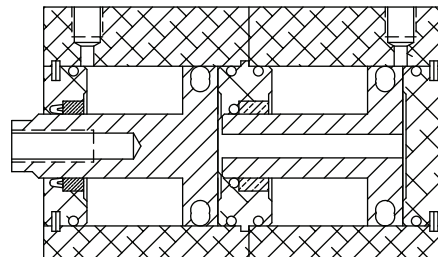

Model - TE

- Extended internal front rod bearing for additional load support
- Integral seal and rod wiper

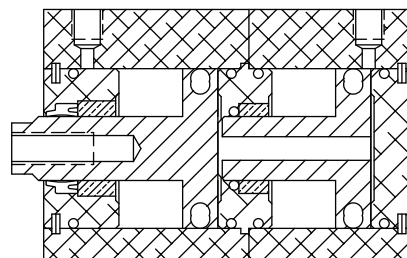

Model - TH

- Extended internal front rod bearing for additional load support
- Integral seal and rod wiper
- Wear band added to front piston for additional load support

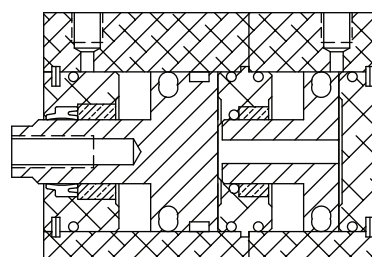

How To Order

Example: Medium Duty, 50mm Bore, 25mm stroke, Tapped Side Mounting, Magnetic Piston, Inch threads, 17mm Total Rod Extension

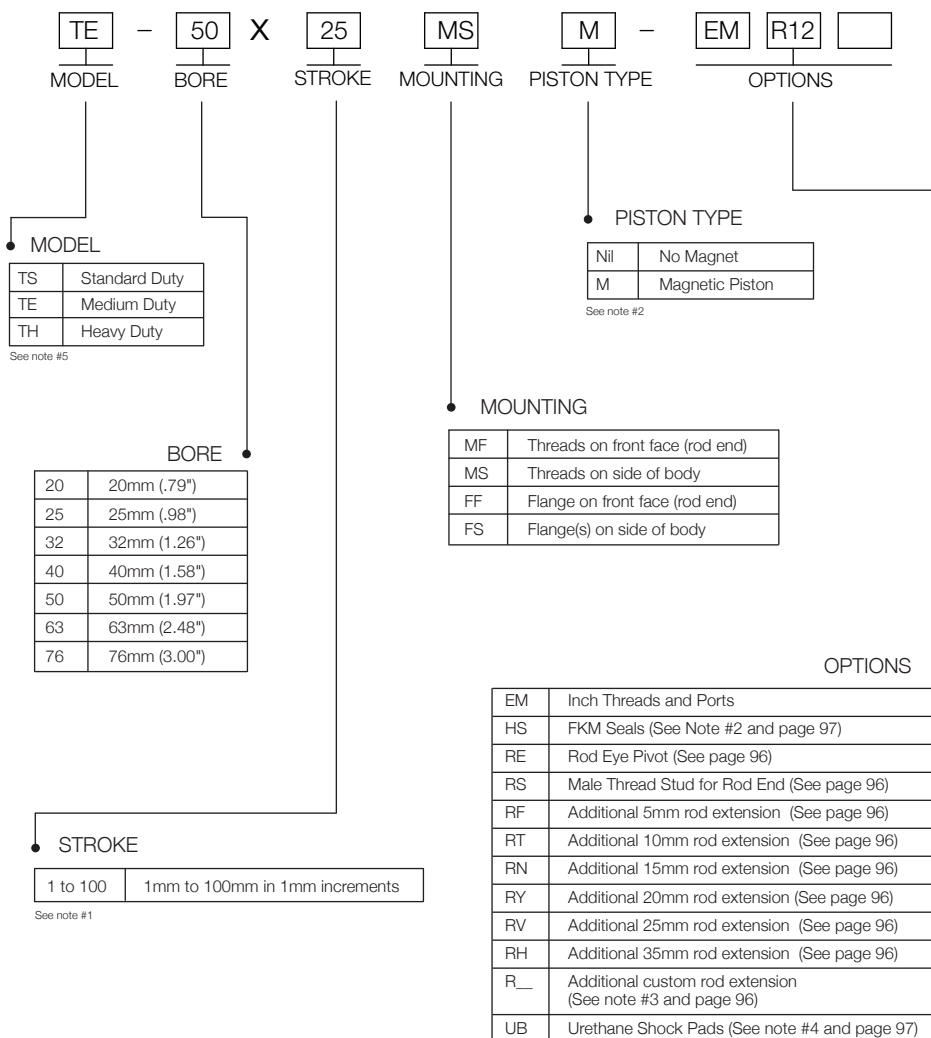

Note 1 - All models use a 5mm stroke body length for Rear Cylinder Stroke of 5mm or less. Rear Cylinder Strokes over 5mm use body length of the actual stroke + adder. Model TS with a Nonmagnetic Piston uses a 9mm stroke body length for Front Cylinder Stroke of 9mm or less. Front Cylinder Strokes over 9mm use body length of the actual stroke + adder. Model TS with Code "M" Magnetic Piston uses a 4mm stroke body length for Front Cylinder Stroke of 4mm or less. Front Cylinder Strokes over 4mm use body length of the actual stroke + adder. Model TE 20, 25, & 32mm Bore with a Nonmagnetic Piston uses a 4mm stroke body length for Front Cylinder Stroke of 4mm or less. Front Cylinder Strokes over length of the actual stroke + adder. All other TE and TH bores and piston combinations use body length of the actual stroke + adder for Front Cylinder. Examples: TS-20X4FF-EM would have a Total Length of 5+9+Dim"A" and a Rear Cylinder Stroke body Length of 5+16.36(Rear Cylinder Length Adder). See Product Page. TS-20X10MS-RE would have a Total Length of (10x2)+Dim"A" and a Rear Cylinder Stroke body length of 10+16.36(Rear Cylinder Length Adder). See Product Page.

Note 2 - Magnetic Piston "M" limits temperature range to -10°C to 82°C (14°F to 180°F). This temperature rating overrides ALL OTHER TEMPERATURE ratings (Standard Seals, HS Seals, etc.). Magnetic Piston and Sensor mounting tracks are provided on Front Stroke Cylinder only.

Note 3 - "R_" Enter desired additional Custom Length Rod extension in mm after "R". Example TE-32X40MSM-EMR20.4 would have a TOTAL ROD EXTENSION of 25.4mm (20.4mm+Standard 5mm extension)

Note 4 - "UB" Urethane Shock Pads limit temperature range to -10°C to 82°C (14°F to 180°F). This temperature rating overrides ALL OTHER TEMPERATURE ratings (Standard Seals, HS Seals, etc.). Pads are mechanically retained at the four Cap faces. "UB" OPTION CHANGES STROKE TOLERANCES TO +/-2mm.

Note 5 - While all Models are offered in all strokes, it is recommended that strokes over 50mm use TE or TH Models for added bearing support.

Engineering Data

Bore	Piston Area Extend	Piston Area Retract	Min. Operating Pressure	Max. Operating Pressure
20	5,78 cm ² (.88 in ²)	2,64 cm ² (.40 in ²)	0.10 MPa (15 PSI)	1.4 MPa (200 PSI)
25	9,03 cm ² (1.40 in ²)	4,12 cm ² (.64 in ²)	0.10 MPa (15 PSI)	1.4 MPa (200 PSI)
32	14,95 cm ² (2.32 in ²)	6,91 cm ² (1.07 in ²)	0.08 MPa (12 PSI)	1.4 MPa (200 PSI)
40	23,11 cm ² (3.59 in ²)	10,55 cm ² (1.64 in ²)	0.08 MPa (12 PSI)	1.4 MPa (200 PSI)
50	37,25 cm ² (5.77 in ²)	17,62 cm ² (2.73 in ²)	0.07 MPa (10 PSI)	1.4 MPa (200 PSI)
63	59,20 cm ² (9.17 in ²)	28,03 cm ² (4.34 in ²)	0.07 MPa (10 PSI)	1.4 MPa (200 PSI)
76	88,06 cm ² (13.66 in ²)	42,46 cm ² (6.59 in ²)	0.07 MPa (10 PSI)	1.4 MPa (200 PSI)

Specifications

Action	Double Acting, 2 Piston Push
Media	Air - Clean, Dry Or Lubricated
Pre-Lubricated at Factory	Non-soap elastomer/PTFE thickener
Temp. Range (Std.)	-10°C to 93°C (14°F to 200°F)
Temp. Range (Mag. Piston)	-10°C to 82°C (14°F to 180°F) See Note 2 & 3
Temp. Range (UB Option)	-10°C to 82°C (14°F to 180°F) See Note 2 & 3
Temp. Range (HS Option)	-10°C to 150°C (14°F to 302°F) See Note 2 & 3
Stroke Tolerance (Std)	+1,0mm/-0 (+0.04"/-0)
Stroke Tolerance (UB)	+/-2mm (+/- .08")

Available Strokes

1 to 100	1mm to 100mm in 1mm increments
----------	--------------------------------

Note 1 - All models use a 5mm stroke body length for Rear Cylinder Stroke of 5mm or less. Rear Cylinder Strokes over 5mm use body length of the actual stroke + adder. Model TS with a Nonmagnetic Piston uses a 9mm stroke body length for Front Cylinder Stroke of 9mm or less. Front Cylinder Strokes over 9mm use body length of the actual stroke + adder.

Model TS with Code "M" Magnetic Piston uses a 4mm stroke body length for Front Cylinder Stroke of 4mm or less. Front Cylinder Strokes over 4mm use body length of the actual stroke + adder.

Model TE 20, 25, & 32mm Bore with a Nonmagnetic Piston uses a 4mm stroke body length for Front Cylinder Stroke of 4mm or less. Front Cylinder Strokes over 4mm use body length of the actual stroke + adder.

All other TE and TH bores and piston combinations use body length of the actual stroke + adder for Front Cylinder.

Examples: TS-20X4FF-EM would have a Total Length of 5+9+Dim"A" and a Rear Cylinder Stroke body Length of 5+16.36(Rear Cylinder Length Adder). See Product Page.

TS-20X10MS-RE would have a Total Length of (10x2)+Dim"A" and a Rear Cylinder Stroke body length of 10+16.36(Rear Cylinder Length Adder). See Product Page.

Note 2 - Magnetic Piston "M" limits temperature range to -10°C to 82°C (14°F to 180°F). This temperature rating overrides ALL OTHER TEMPERATURE ratings (Standard Seals, HS Seals, etc.). Magnetic Piston and Sensor mounting tracks are provided on Front Stroke Cylinder only.

Note 3 - "UB" Urethane Shock Pads limit temperature range to -10°C to 82°C (14°F to 180°F). This temperature rating overrides ALL OTHER TEMPERATURE ratings (Standard Seals, HS Seals, etc.). Pads are mechanically retained at the four Cap faces. "UB" OPTION CHANGES STROKE TOLERANCES TO +/-2mm.

Note 4 - While all Models are offered in all strokes, it is recommended that strokes over 50mm use TE or TH Models for added bearing support.

Tandem Piston Cylinder Front Mount Cylinder "MF"

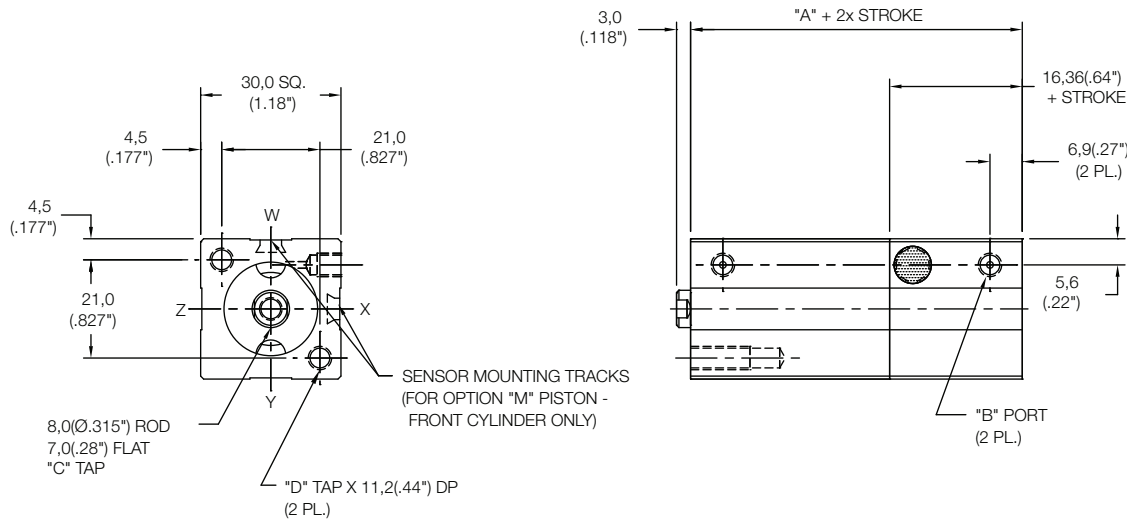

MODEL	PISTON	"A"	"F"	PISTON	"A"	"F"
TS	Non-Mag	34,0(1.34")	40,0mm(1.58")	Mag	39,0(1.54")	35,0mm(1.38")
TE	Non-Mag	39,0(1.54")	35,0mm(1.38")	Mag	44,0(1.73")	30,0mm(1.18")
TH	Non-Mag	44,0(1.73")	30,0mm(1.18")	Mag	49,0(1.93")	25,0mm(.98")

	Standard Threads	"EM" Option
"B"	M5X0,8	#10-32
"C"	M5X0,8	#10-32
"D"	M5X0,8	#10-32
"E"	M4X0,7	#8-32

Side Mount Cylinder "MS"

(All dimensions not shown same as "MF")

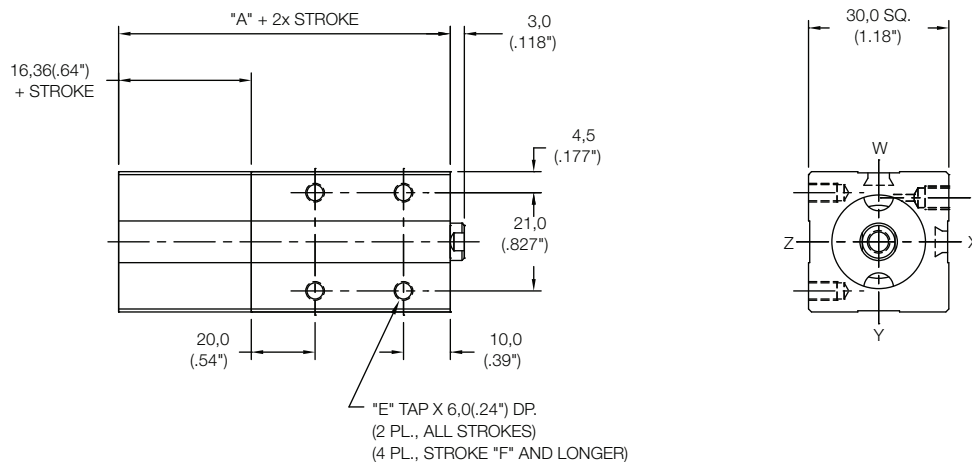

- 20 X -

MODEL BORE STROKE MOUNTING PISTON TYPE OPTIONS

TS
TE
TH

Stroke in 1mm Increments
(See Ordering Information and How It Works)

MF - Front Mount
MS - Side Mount
FF - Front Flange
FS - Side Flange
(For Flanges See Page 92 & 93)

Nil - Nonmagnetic Piston
M - Magnetic piston

- EM - Inch Threads and Ports
- HS - FKM Seals
(See Page 97 and Ordering Information)
- RE - Rod Eye
(See Page 96)
- RS - Male Threaded Stud For Rod End
(See Page 96)
- RF, RT, RN, RY, RV, RH, RL - Rod Extensions
(See Page 96 and Ordering Information)

Tandem Piston Cylinder Front Mount Cylinder "MF"

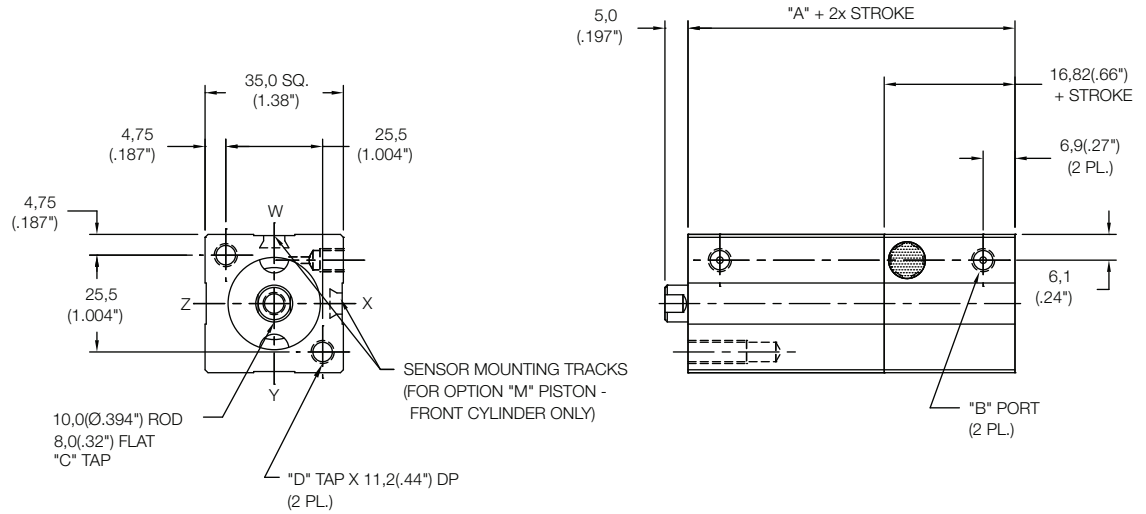

MODEL	PISTON	"A"	"F"	PISTON	"A"	"F"
TS	Non-Mag	35,0(1.38")	40,0mm(1.58")	Mag	40,0(1.58")	35,0mm(1.38")
TE	Non-Mag	40,0(1.58")	35,0mm(1.38")	Mag	45,0(1.77")	30,0mm(1.18")
TH	Non-Mag	45,0(1.77")	30,0mm(1.18")	Mag	50,0(1.97")	25,0mm(.98")

	Standard Threads	"EM" Option
"B"	M5X0,8	#10-32
"C"	M5X0,8	#10-32
"D"	M5X0,8	#10-32
"E"	M5X0,8	#10-32

Side Mount Cylinder "MS"

(All dimensions not shown same as "MF")

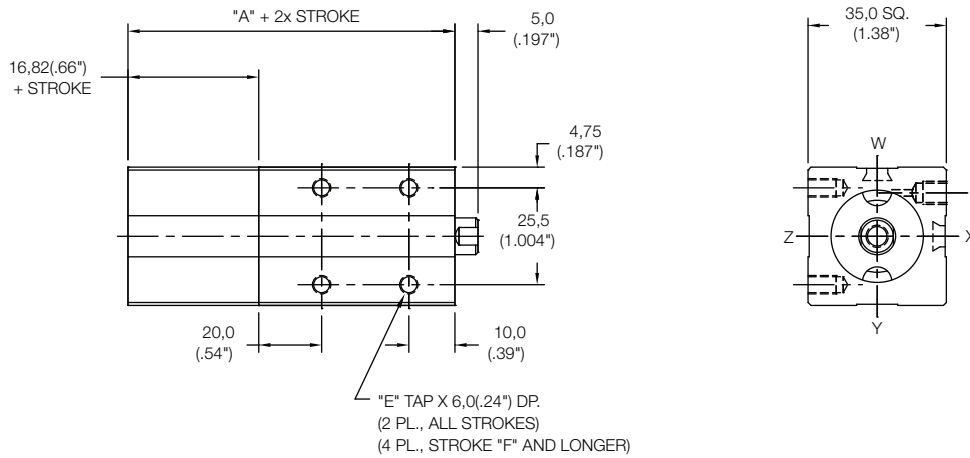

Stroke in 1mm Increments
(See Ordering Information and How It Works)

MF - Front Mount
MS - Side Mount
FF - Front Flange
FS - Side Flange
(For Flanges See Page 92 & 93)

- EM - Inch Threads and Ports
- HS - FKM Seals
(See Page 97 and Ordering Information)
- RE - Rod Eye
(See Page 96)
- RS - Male Threaded Stud For Rod End
(See Page 96)
- RF, RT, RN, RY, RV, RH, R_L - Rod Extensions
(See Page 96 and Ordering Information)

Nil - Nonmagnetic Piston
M - Magnetic piston

**Tandem Piston Cylinder
Front Mount Cylinder "MF"**

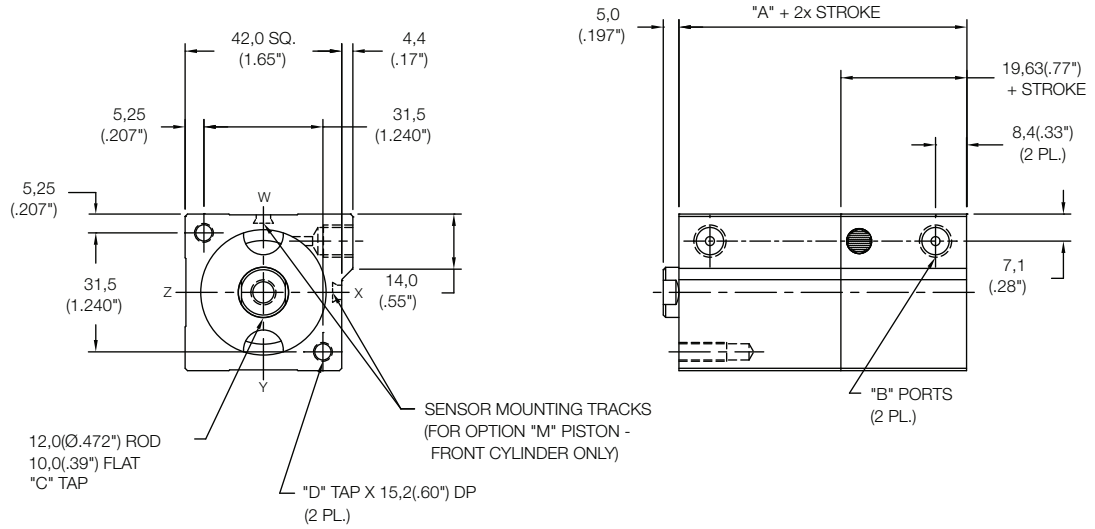

MODEL	PISTON	"A"	"F"	PISTON	"A"	"F"
TS	Non-Mag	41,0(1.61")	40,0mm(1.58")	Mag	46,0(1.81")	35,0mm(1.38")
TE	Non-Mag	46,0(1.81")	35,0mm(1.38")	Mag	51,0(2.01")	30,0mm(1.18")
TH	Non-Mag	51,0(2.01")	30,0mm(1.18")	Mag	56,0(2.21")	25,0mm(.98")

	Standard Threads	"EM" Option
"B"	G1/8 PORT	1/8-27
"C"	M6X1,0	1/4-20
"D"	M6X1,0	1/4-20
"E"	M5X0,8	10-32

Side Mount Cylinder "MS"

(All dimensions not shown same as "MF")

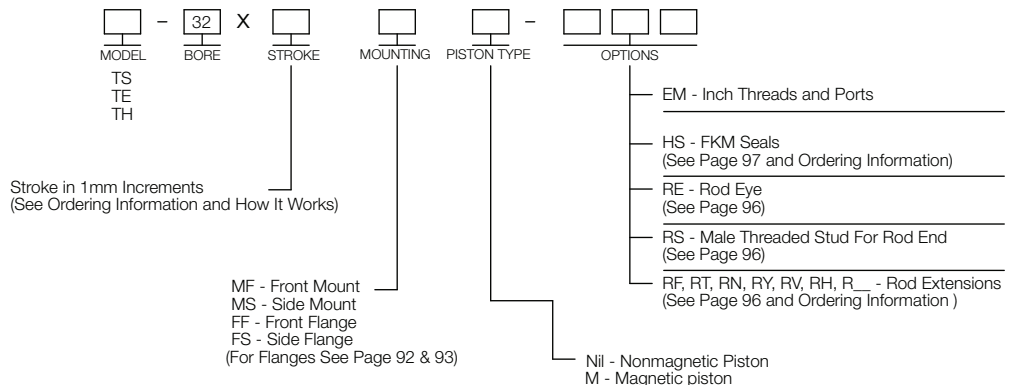
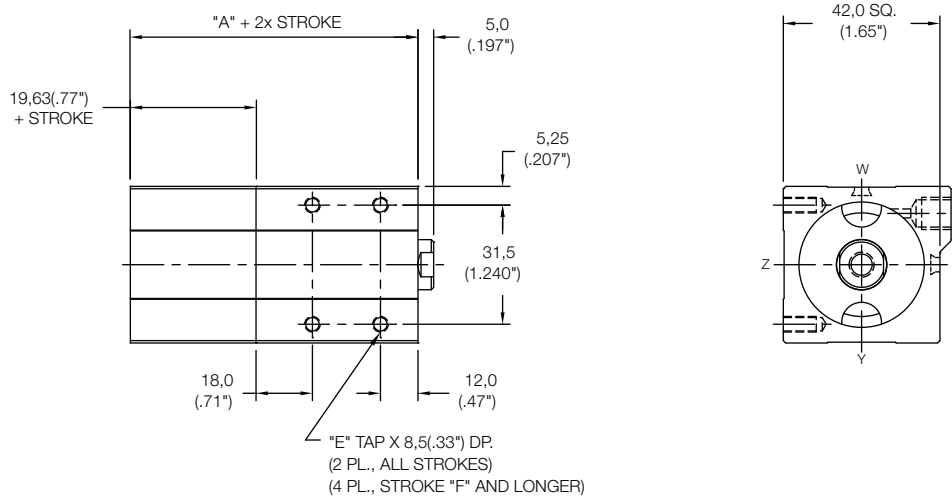

Tandem Piston Cylinder Front Mount Cylinder "MF"

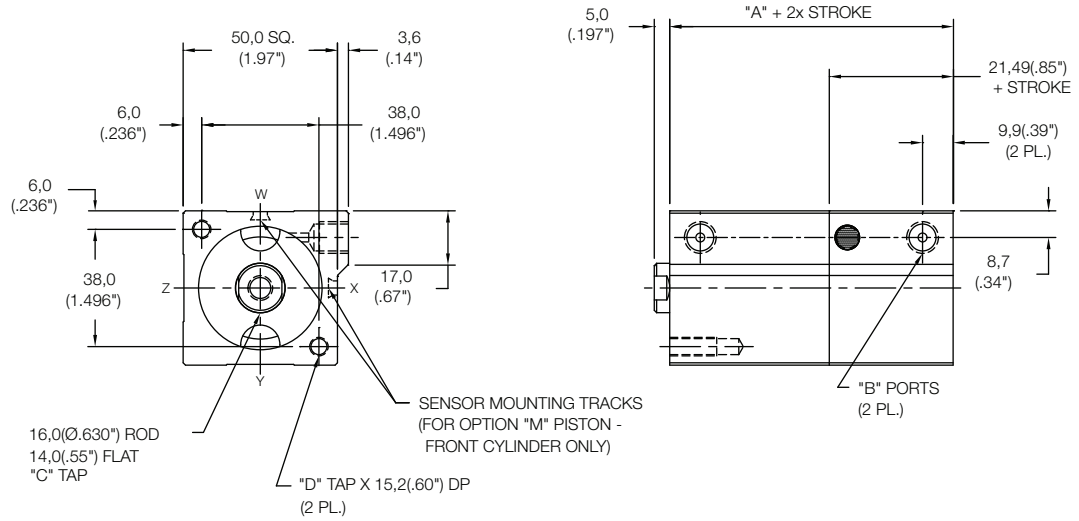

MODEL	PISTON	"A"	"F"	PISTON	"A"	"F"
TS	Non-Mag	45,0(1.77")	40,0mm(1.58")	Mag	50,0(1.97")	35,0mm(1.38")
TE	Non-Mag	55,0(2.17")	30,0mm(1.18")	Mag	60,0(2.36")	25,0mm(.98")
TH	Non-Mag	60,0(2.36")	25,0mm(.98")	Mag	65,0(2.56")	20,0mm(.79")

	Standard Threads	"EM" Option
"B"	G1/8 PORT	1/8-27
"C"	M8X1,25	5/16-18
"D"	M6X1,0	1/4-20
"E"	M6X1,0	1/4-20

Side Mount Cylinder "MS"

(All dimensions not shown same as "MF")

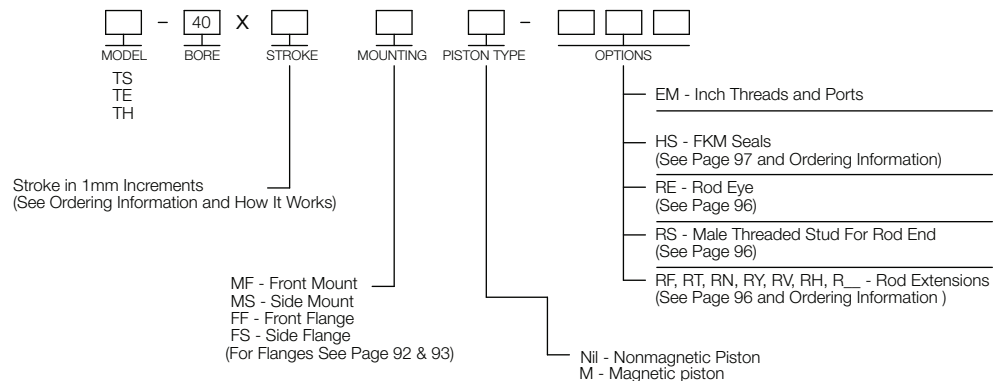
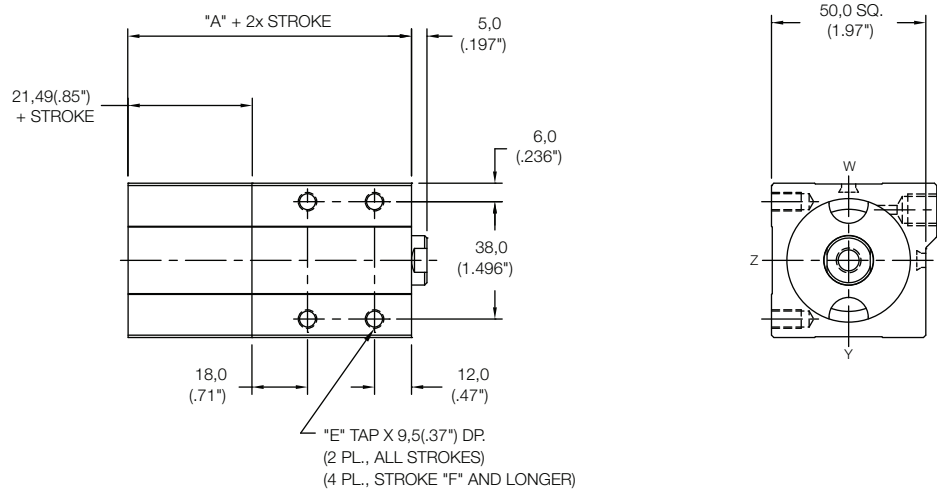

Tandem Piston Cylinder Front Mount Cylinder "MF"

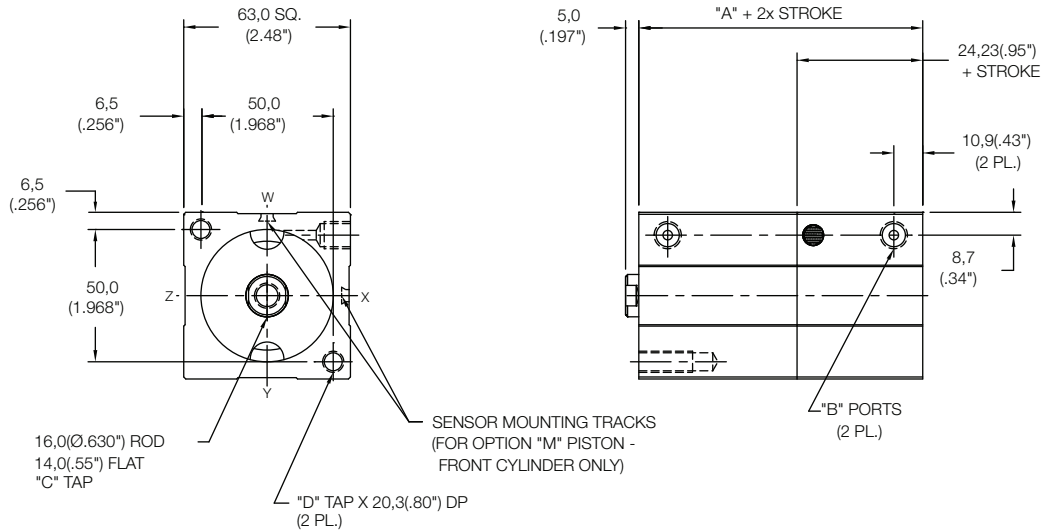

MODEL	PISTON	"A"	"F"	PISTON	"A"	"F"
TS	Non-Mag	51,0(2.01")	40,0mm(1.58")	Mag	56,0(2.20")	35,0mm(1.38")
TE	Non-Mag	61,0(2.40")	30,0mm(1.18")	Mag	66,0(2.60")	25,0mm(.98")
TH	Non-Mag	66,0(2.60")	25,0mm(.98")	Mag	71,0(2.80")	20,0mm(.79")

	Standard Threads	"EM" Option
"B"	G1/8 PORT	1/8-27
"C"	M10X1,5	3/8-24
"D"	M8X1,25	5/16-18
"E"	M8X1,25	5/16-18

Side Mount Cylinder "MS"

(All dimensions not shown same as "MF")

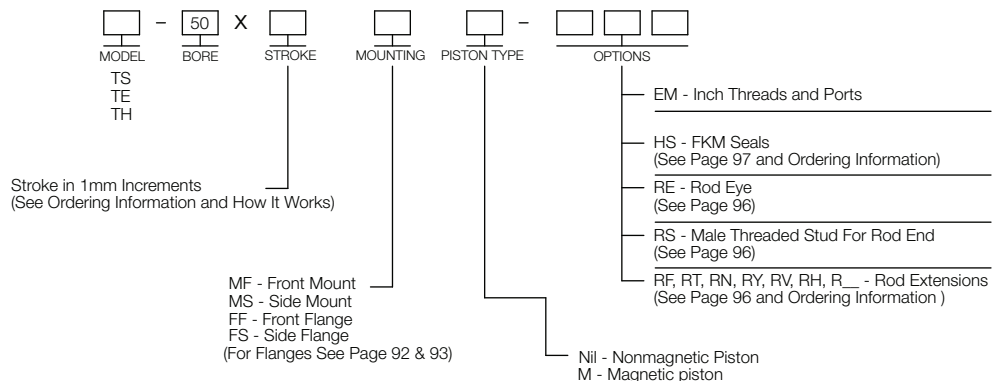
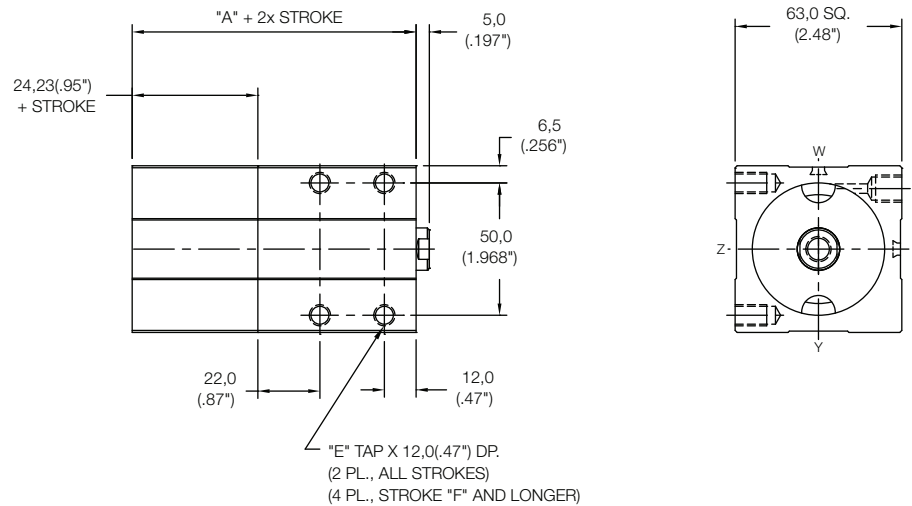

**Tandem Piston Cylinder
Front Mount Cylinder "MF"**

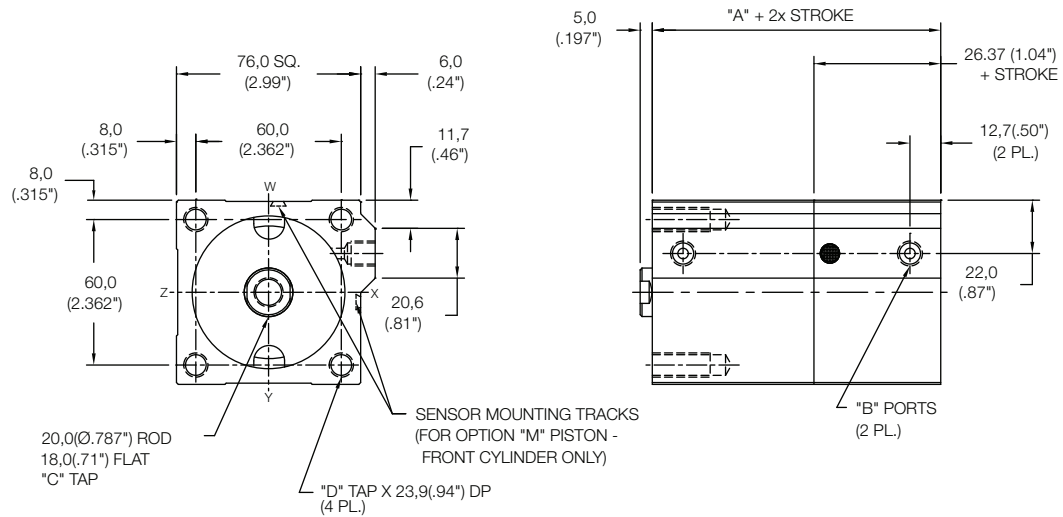

MODEL	PISTON	"A"	"F"	PISTON	"A"	"F"
TS	Non-Mag	56,0(2.20")	45,0mm(1.77")	Mag	61,0(2.40")	40,0mm(1.58")
TE	Non-Mag	66,0(2.60")	35,0mm(1.38")	Mag	71,0(2.80")	30,0mm(1.18")
TH	Non-Mag	76,0(2.99")	25,0mm(.98")	Mag	81,0(3.19")	20,0mm(.79")

	Standard Threads	"EM" Option
"B"	G1/8 PORT	1/8-27
"C"	M12X1,75	1/2-13
"D"	M10X1,5	3/8-24
"E"	M8X1.25	5/16-18

Side Mount Cylinder "MS"

(All dimensions not shown same as "MF")

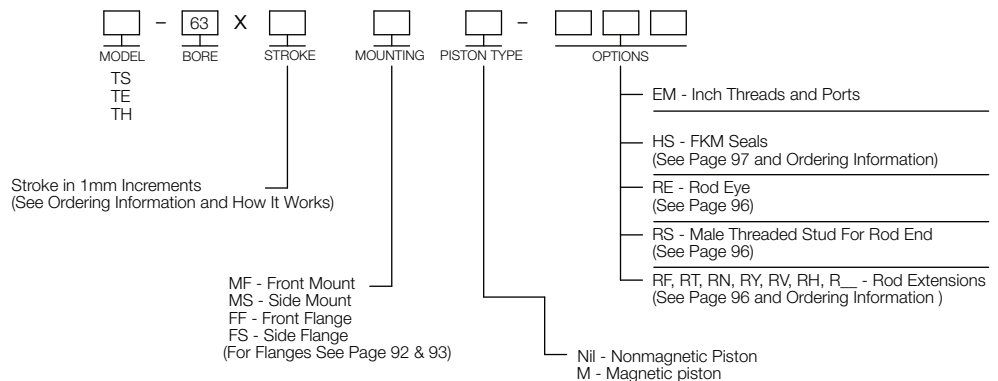
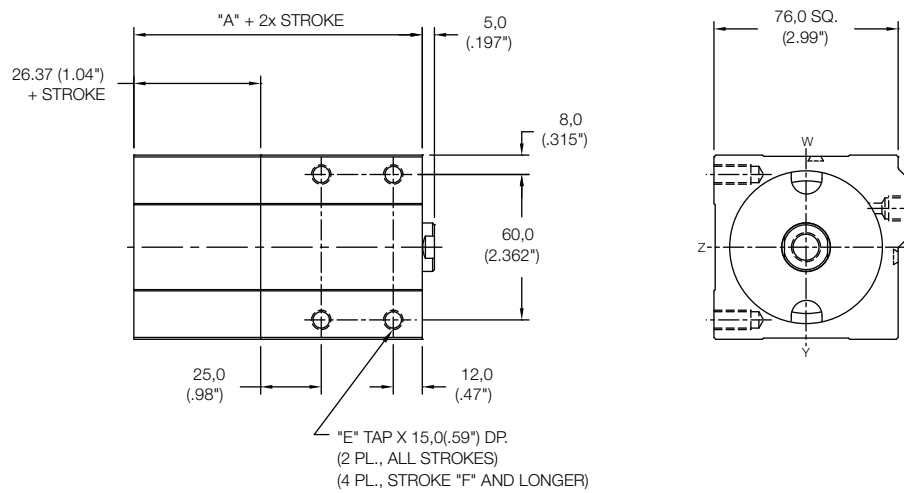

Tandem Piston Cylinder Front Mount Cylinder "MF"

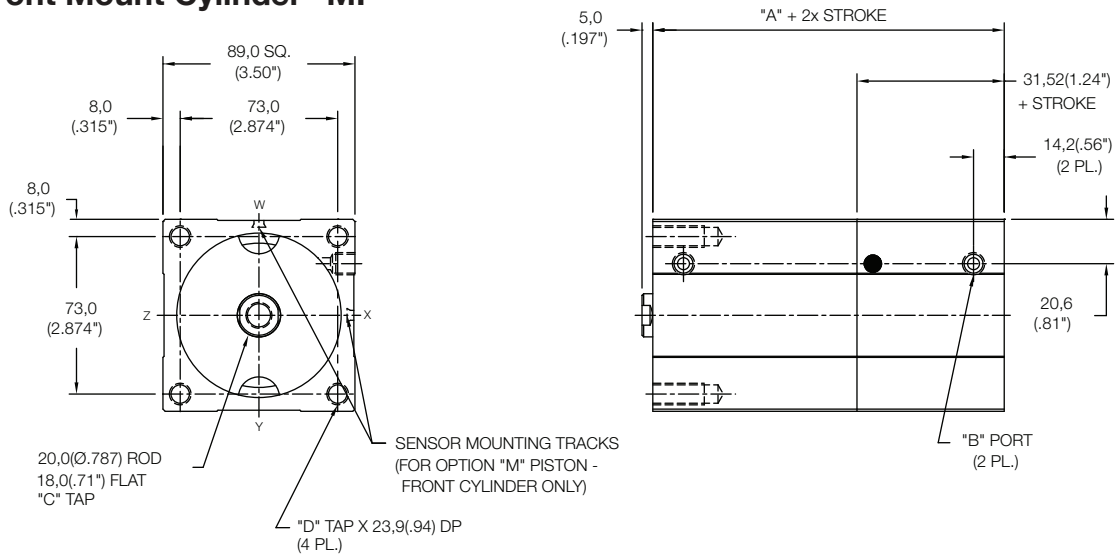

MODEL	PISTON	"A"	"F"	PISTON	"A"	"F"
TS	Non-Mag	67,0(2.64")	45,0mm(1.77")	Mag	72,0(2.83")	40,0mm(1.58")
TE	Non-Mag	77,0(3.03")	35,0mm(1.38")	Mag	82,0(3.23")	30,0mm(1.18")
TH	Non-Mag	87,0(3.43")	25,0mm(.98")	Mag	92,0(3.62")	20,0mm(.79")

	Standard Threads	"EM" Option
"B"	G1/8 PORT	1/8-27
"C"	M12X1,75	1/2-13
"D"	M10X1,5	3/8-24
"E"	M10X1,5	3/8-24

Side Mount Cylinder "MS"

(All dimensions not shown same as "MF")

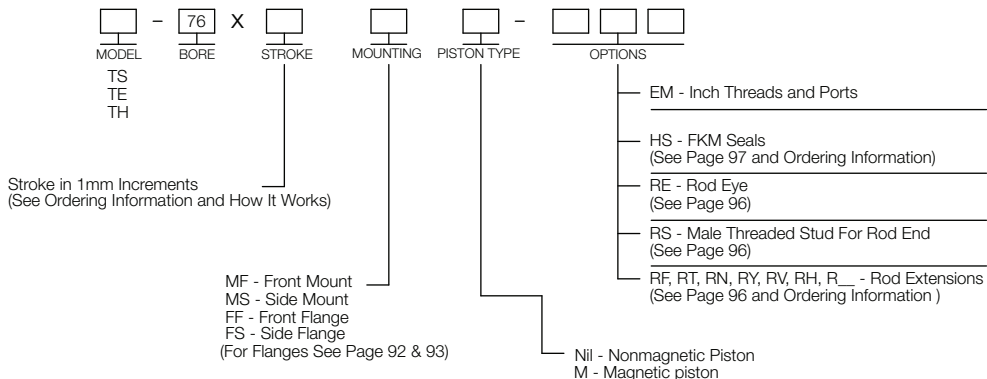
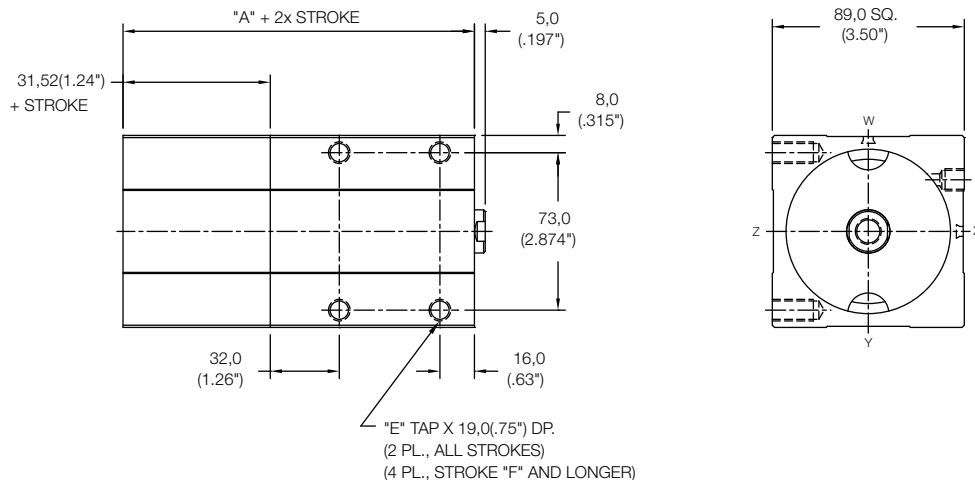

PS SERIES

PNEUMATIC CYLINDERS

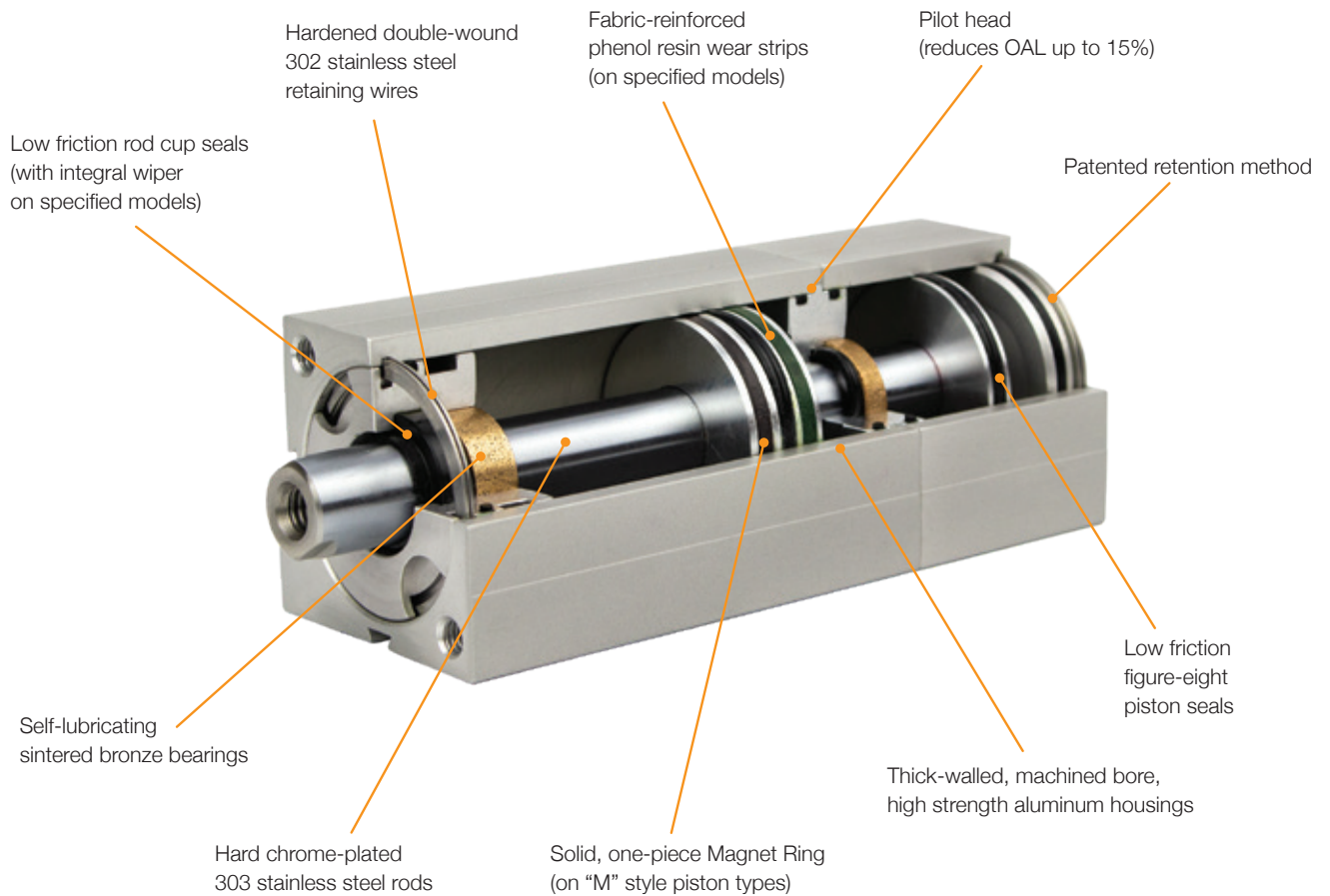

Multi-Position 3 Position Pneumatic Cylinders

The P series cylinder line is based on the same rugged, proven designs of Nason's L series cylinders. Thick-walled, custom aluminum extrusions are precision bored and honed. High strength aluminum internal components are machined to exacting tolerances to control seal squeezes and stroke tolerances. Chrome-plated 303 stainless steel rods are precision-ground for long life. The dual piloted head design aligns bores and rods and helps reduce overall length up to 15% compared to two standard units bolted together.

3 Position Multi-Position Cylinder

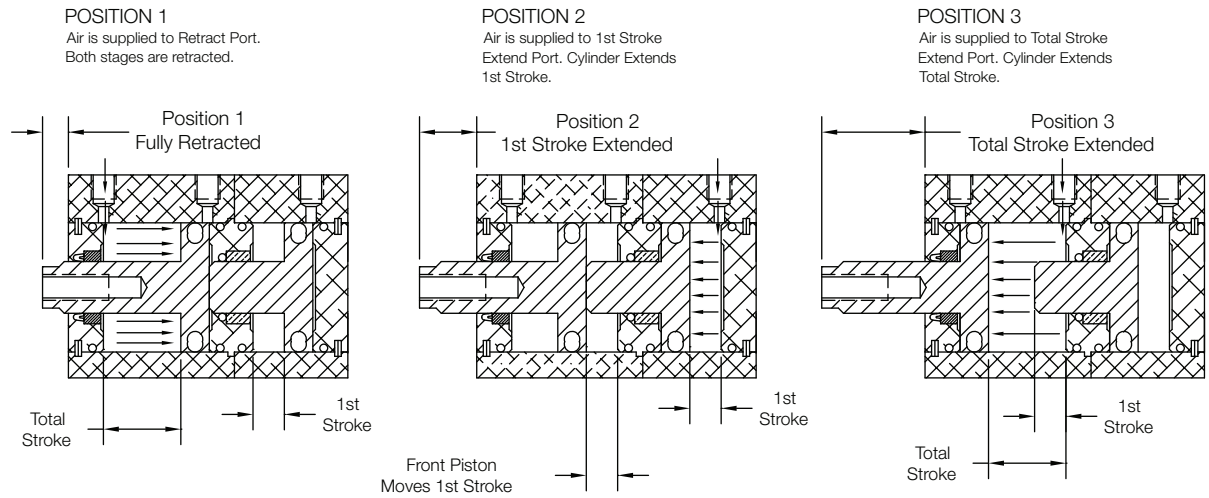

Individual Features

Model - PS

- Most compact of 3 models

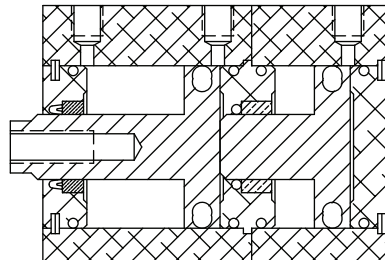

Model - PE

- Extended internal front rod bearing for additional load support
- Integral seal and rod wiper

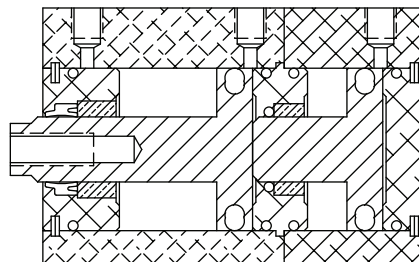

Model - PH

- Extended internal front rod bearing for additional load support
- Integral seal and rod wiper
- Wear band added to front piston for additional load support

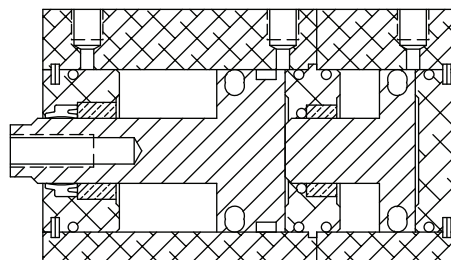

How To Order

Example: Medium Duty, 50mm Bore, 25mm stroke + 30mm Stroke (55mm Total Stroke), Flange Side Mounting, Magnetic Piston, Inch threads, 17mm Total Rod Extension, Urethane Shock Pads

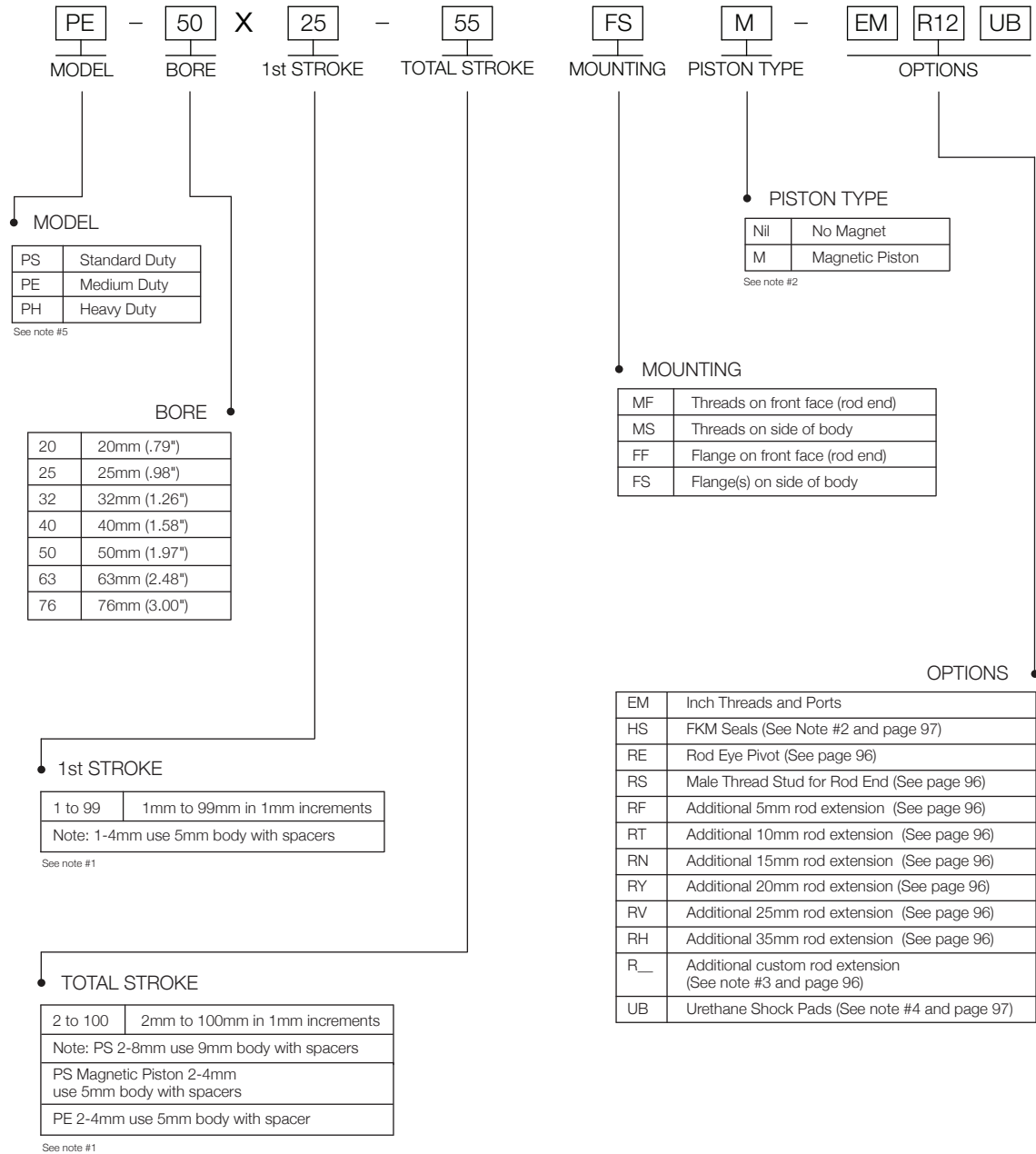

Note 1 - All models use a 5mm stroke body length for 1st Stroke of 5mm or less. 1st Strokes over 5mm use body length of the actual stroke + adder. Model PS with a Nonmagnetic Piston uses a 9mm stroke body length for Total Stroke of 9mm or less. Total Strokes over 9mm use body length of the actual stroke + adder. Model PS with Code "M" Magnetic Piston uses a 4mm stroke body length for Total Stroke of 4mm or less. Total Strokes over 4mm use body length of the actual stroke + adder. Model PE with a Nonmagnetic Piston uses a 4mm stroke body length for Total Stroke of 4mm or less. Total Strokes over 4mm use body length of the actual stroke + adder. Examples: PS-20X3-8FF-EM would have a Total Length of 5+9+34(Dim"A") and a 1st Stroke body Length of 5+16.36(1st Stroke Length Adder). See 20mm Product Page. PS-20X6-10MS-RE would have a Total Length of 6+10+34(Dim"A") and a 1st Stroke body length of 6+16.36(1st Stroke Length Adder). See 20mm Product Page.

Note 2 - Magnetic Piston "M" limits temperature range to -10°C to 82°C (14°F to 180°F). This temperature rating overrides ALL OTHER TEMPERATURE ratings (Standard Seals, HS Seals, etc.). Magnetic Piston and Sensor mounting tracks are provided on Front (Total Stroke) Cylinder only.

Note 3 - "R_" Enter desired additional Custom Length Rod extension in mm after "R". Example PE-32X40-90MSM-EMR20.4 would have a TOTAL ROD EXTENSION of 25.4mm (20.4mm+Standard 5mm extension)

Note 4 - "UB" Urethane Shock Pads limit temperature range to -10°C to 82°C (14°F to 180°F). This temperature rating overrides ALL OTHER TEMPERATURE ratings (Standard Seals, HS Seals, etc.). Pads are mechanically retained at the four Cap faces. "UB" OPTION CHANGES STROKE TOLERANCES TO +/-4mm.

Note 5 - While all Models are offered in all strokes, it is recommended that total strokes over 50mm use PE or PH Models for added bearing support.

Engineering Data

Bore	Piston Area Extend	Piston Area Retract	Min. Operating Pressure	Max. Operating Pressure
20	3,14 cm ² (.48 in ²)	2,64 cm ² (.40 in ²)	0.10 MPa (15 PSI)	1.4 MPa (200 PSI)
25	4,91 cm ² (.76 in ²)	4,12 cm ² (.64 in ²)	0.10 MPa (15 PSI)	1.4 MPa (200 PSI)
32	8,04 cm ² (1.25 in ²)	6,91 cm ² (1.07 in ²)	0.08 MPa (12 PSI)	1.4 MPa (200 PSI)
40	12,56 cm ² (1.95 in ²)	10,55 cm ² (1.64 in ²)	0.08 MPa (12 PSI)	1.4 MPa (200 PSI)
50	19,63 cm ² (3.04 in ²)	17,62 cm ² (2.73 in ²)	0.07 MPa (10 PSI)	1.4 MPa (200 PSI)
63	31,17 cm ² (4.83 in ²)	28,03 cm ² (4.34 in ²)	0.07 MPa (10 PSI)	1.4 MPa (200 PSI)
76	45,60 cm ² (7.07 in ²)	42,46 cm ² (6.59 in ²)	0.07 MPa (10 PSI)	1.4 MPa (200 PSI)

Specifications

Action	Double Acting, 3 Position
Media	Air - Clean, Dry Or Lubricated
Pre-Lubricated at Factory	Non-soap elastomer/PTFE thickener
Temp. Range (Std.)	-10°C to 93°C (14°F to 200°F)
Temp. Range (Mag. Piston)	-10°C to 82°C (14°F to 180°F) See Note 2 & 3
Temp. Range (UB Option)	-10°C to 82°C (14°F to 180°F) See Note 2 & 3
Temp. Range (HS Option)	-10°C to 150°C (14°F to 302°F) See Note 2 & 3
Stroke Tolerance (Std)	+1,0mm/-0 (+0.04"/-0)
Stroke Tolerance (UB)	+/-2mm (+/- .08")

Available Strokes

First Stroke (See Note 1)	1mm to 99mm in 1mm increments
Total Stroke (See Note 1)	2mm to 100mm in 1mm increments

- Note 1 - All models use a 5mm stroke body length for 1st Stroke of 5mm or less. 1st Strokes over 5mm use body length of the actual stroke + adder.
 All Model PS with a Nonmagnetic Piston uses a 9mm stroke body length for Total Stroke of 9mm or less. Total Strokes over 9mm use body length of the actual stroke + adder.
 All Model PS with Code "M" Magnetic Piston uses a 4mm stroke body length for Total Stroke of 4mm or less. Total Strokes over 4mm use body length of the actual stroke + adder.
 Model PE 20,25, & 32mm Bore with a Nonmagnetic Piston uses a 4mm stroke body length for Total Stroke of 4mm or less. Total Strokes over 4mm use body length of the actual stroke + adder.
 All other models, bores and piston combinations use body length of the actual stroke + adder.
- Note 2 - Magnetic Piston "M" limits temperature range to -10°C to 82°C (14°F to 180°F). This temperature rating overrides ALL OTHER TEMPERATURE ratings (Standard Seals, HS Seals, etc.). Magnetic Piston and Sensor mounting tracks are provided on Front (Total Stroke) Cylinder only.
- Note 3 - "UB" Urethane Shock Pads limit temperature range to -10°C to 82°C (14°F to 180°F). This temperature rating overrides ALL OTHER TEMPERATURE ratings (Standard Seals, HS Seals, etc.). Pads are mechanically retained at the four Cap faces. "UB" OPTION CHANGES STROKE TOLERANCES TO +/-2mm.
- Note 4 - While all Models are offered in all strokes, it is recommended that total strokes over 50mm use PE or PH Models for added bearing support.

Multi-Position Cylinder Front Mount Cylinder "MF"

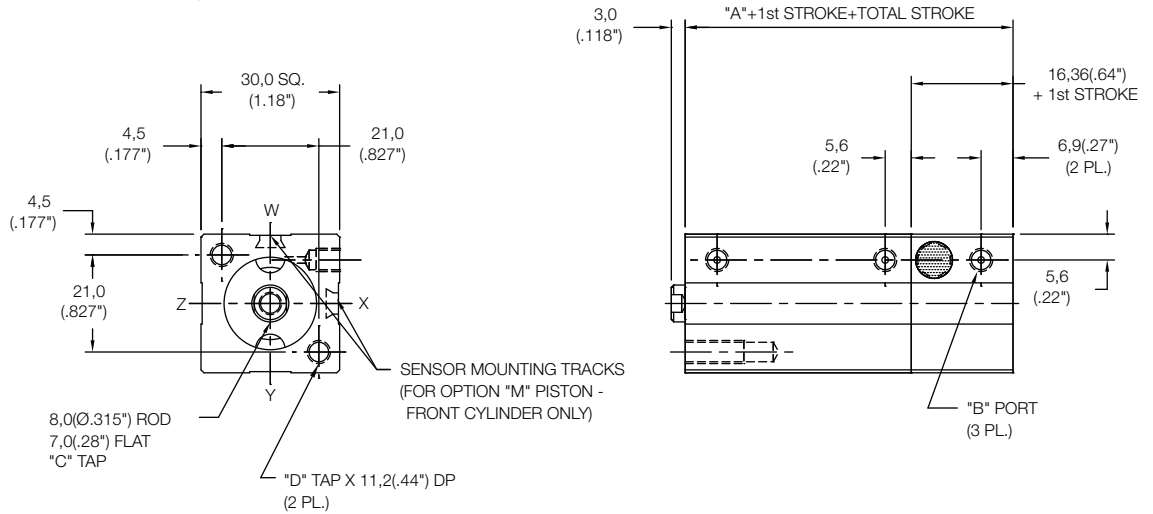

MODEL	PISTON	"A"	"F"	PISTON	"A"	"F"
PS	Non-Mag	34,0(1.34")	40,0mm(1.58")	Mag	39,0(1.54")	35,0mm(1.38")
PE	Non-Mag	39,0(1.54")	35,0mm(1.38")	Mag	44,0(1.73")	30,0mm(1.18")
PH	Non-Mag	44,0(1.73")	30,0mm(1.18")	Mag	49,0(1.93")	25,0mm(.98")

	Standard Threads	"EM" Option
"B"	M5X0,8	#10-32
"C"	M5X0,8	#10-32
"D"	M5X0,8	#10-32
"E"	M4X0,7	#8-32

Side Mount Cylinder "MS"

(All dimensions not shown same as "MF")

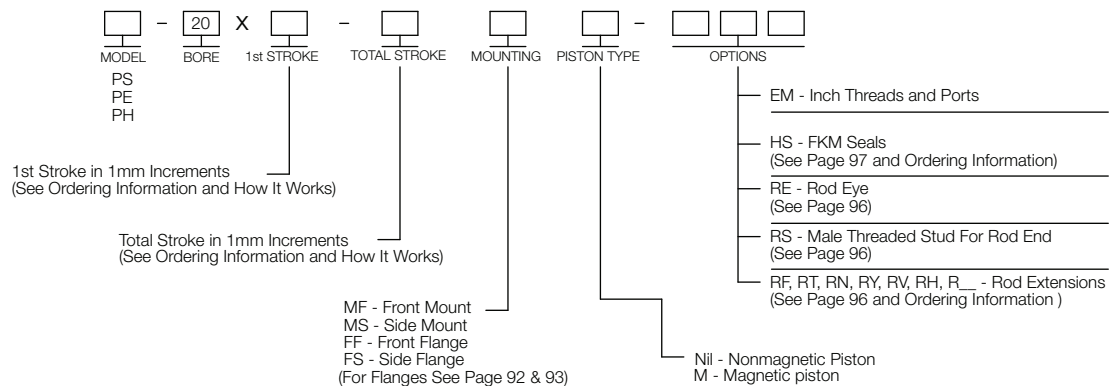
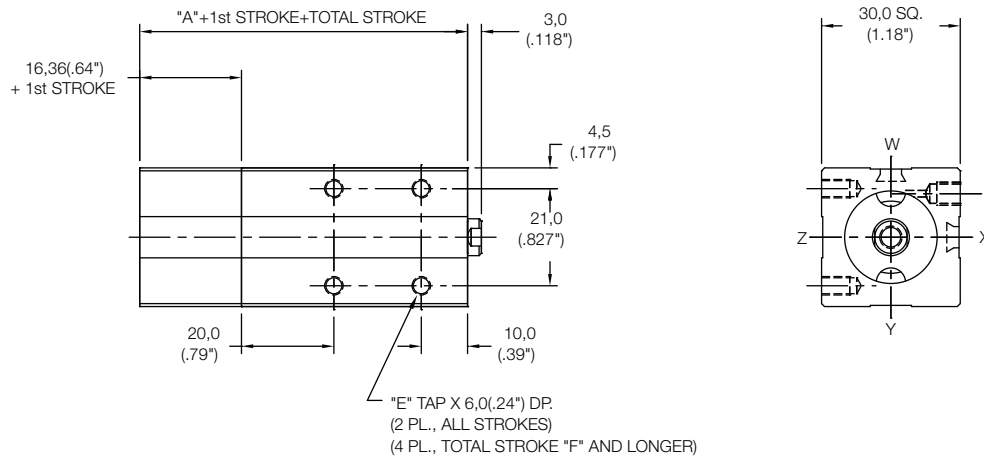

Multi-Position Cylinder Front Mount Cylinder "MF"

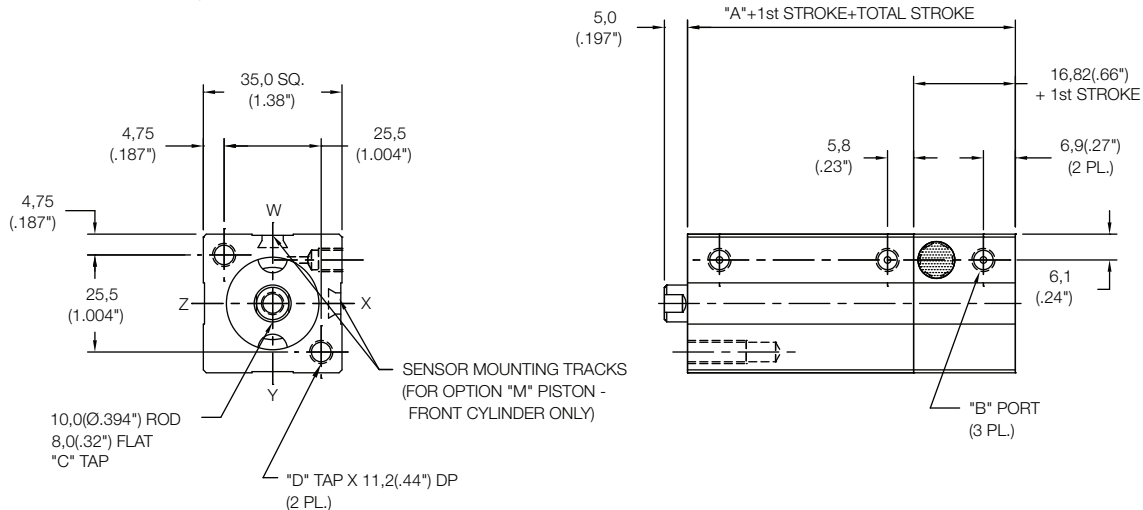

MODEL	PISTON	"A"	"F"	PISTON	"A"	"F"
PS	Non-Mag	35,0(1.38")	40,0mm(1.58")	Mag	40,0(1.58")	35,0mm(1.38")
PE	Non-Mag	40,0(1.58")	35,0mm(1.38")	Mag	45,0(1.77")	30,0mm(1.18")
PH	Non-Mag	45,0(1.77")	30,0mm(1.18")	Mag	50,0(1.97")	25,0mm(.98")

	Standard Threads	"EM" Option
"B"	M5X0,8	#10-32
"C"	M5X0,8	#10-32
"D"	M5X0,8	#10-32
"E"	M5X0,8	#10-32

Side Mount Cylinder "MS"

(All dimensions not shown same as "MF")

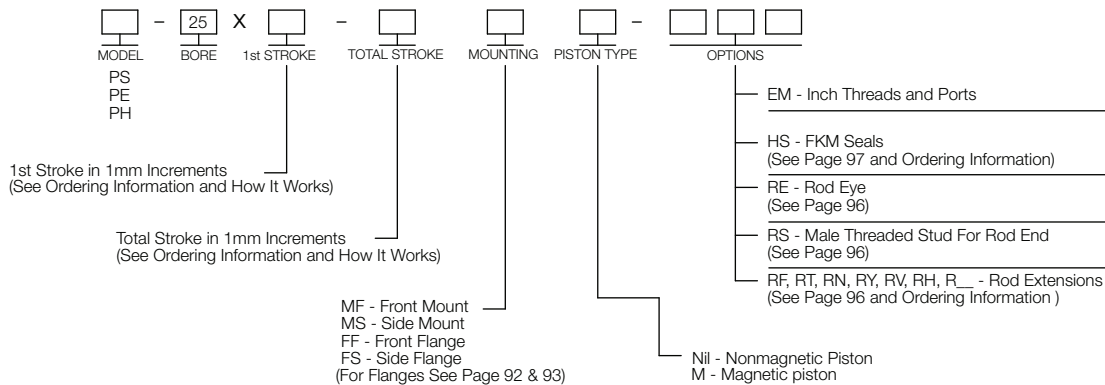
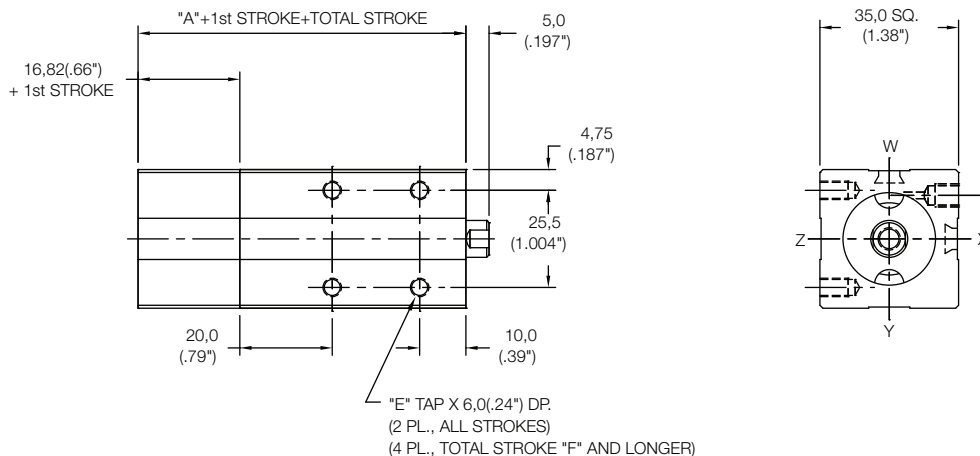

Multi-Position Cylinder Front Mount Cylinder "MF"

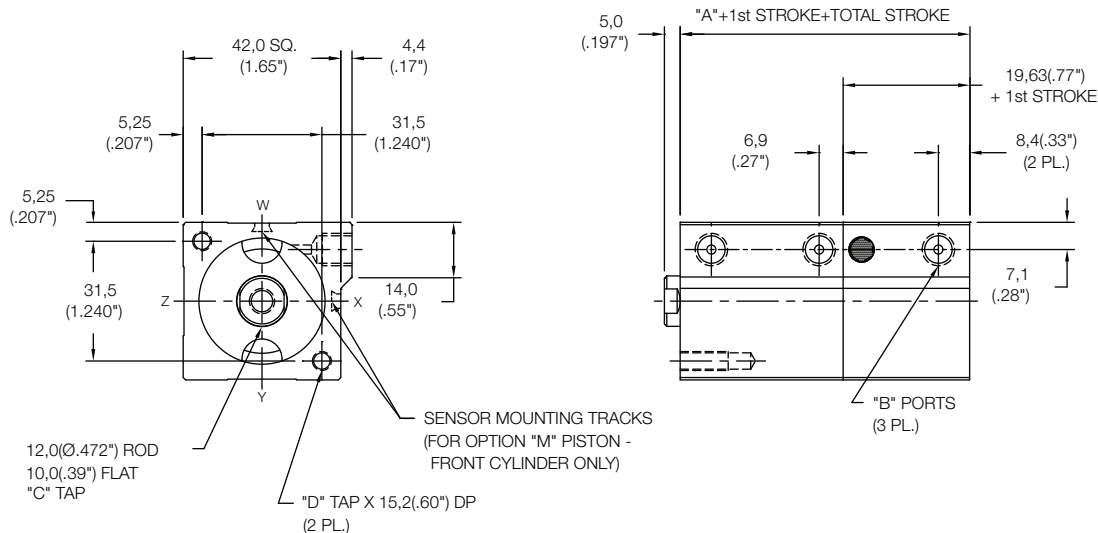

MODEL	PISTON	"A"	"F"	PISTON	"A"	"F"
PS	Non-Mag	41,0(1.61")	40,0mm(1.58")	Mag	46,0(1.81")	35,0mm(1.38")
PE	Non-Mag	46,0(1.81")	35,0mm(1.38")	Mag	51,0(2.01")	30,0mm(1.18")
PH	Non-Mag	51,0(2.01")	30,0mm(1.18")	Mag	56,0(2.21")	25,0mm(.98")

	Standard Threads	"EM" Option
"B"	G1/8 PORT	1/8-27
"C"	M6X1,0	1/4-20
"D"	M6X1,0	1/4-20
"E"	M5X0,8	10-32

Side Mount Cylinder "MS"

(All dimensions not shown same as "MF")

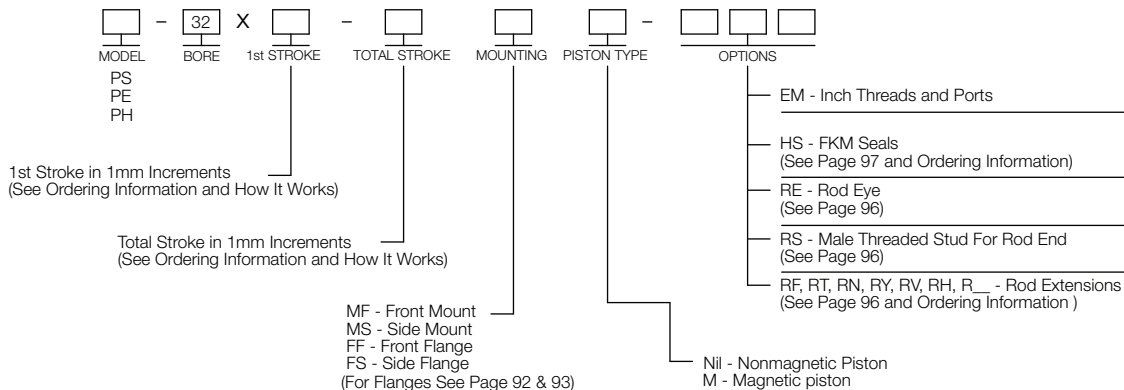
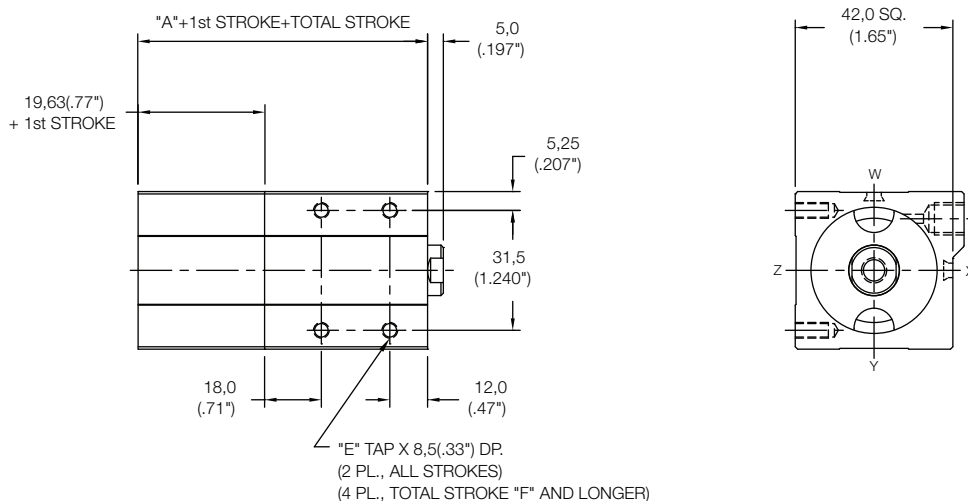

Multi-Position Cylinder Front Mount Cylinder "MF"

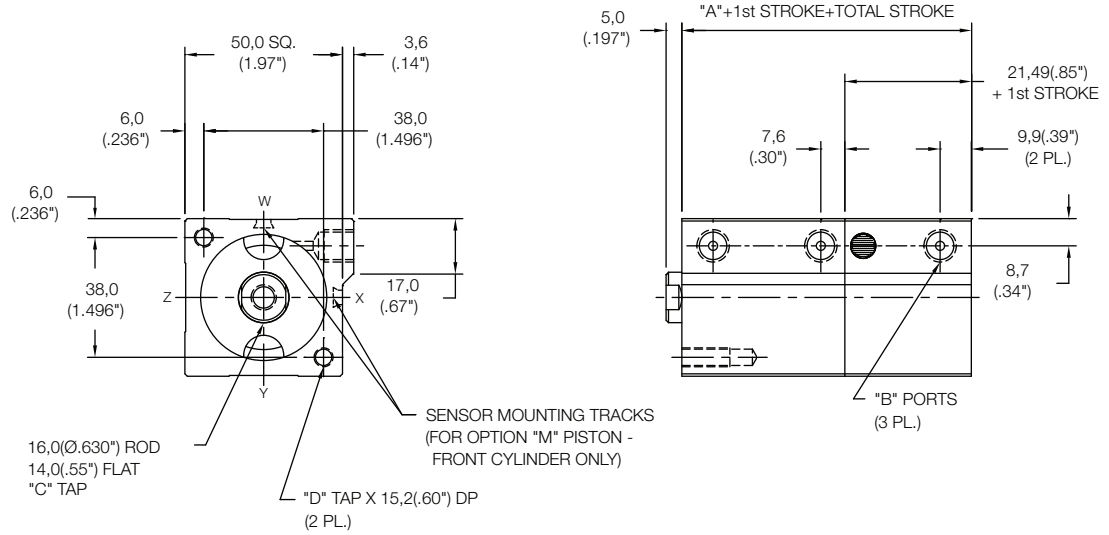

MODEL	PISTON	"A"	"F"	PISTON	"A"	"F"
PS	Non-Mag	45,0(1.77")	40,0mm(1.58")	Mag	50,0(1.97")	35,0mm(1.38")
PE	Non-Mag	55,0(2.17")	30,0mm(1.18")	Mag	60,0(2.36")	25,0mm(.98")
PH	Non-Mag	60,0(2.36")	25,0mm(.98")	Mag	65,0(2.56")	20,0mm(.79")

	Standard Threads	"EM" Option
"B"	G1/8 PORT	1/8-27
"C"	M8X1,25	5/16-18
"D"	M6X1,0	1/4-20
"E"	M6X1,0	1/4-20

Side Mount Cylinder "MS"

(All dimensions not shown same as "MF")

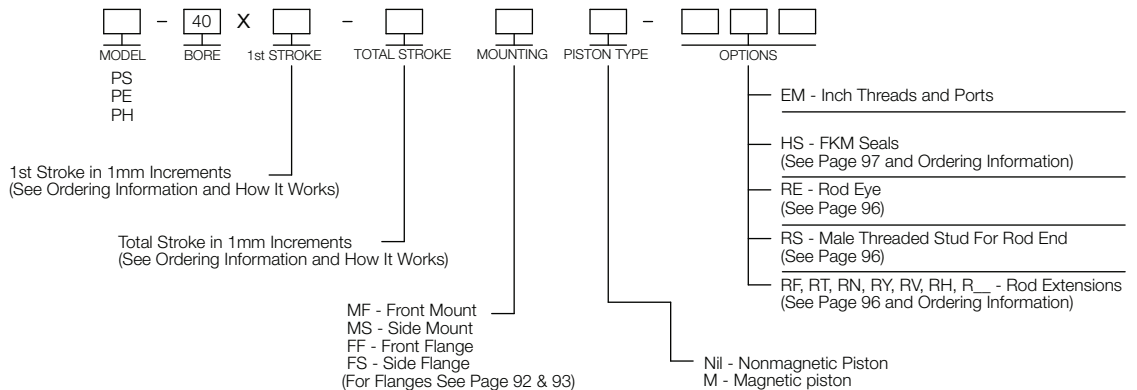
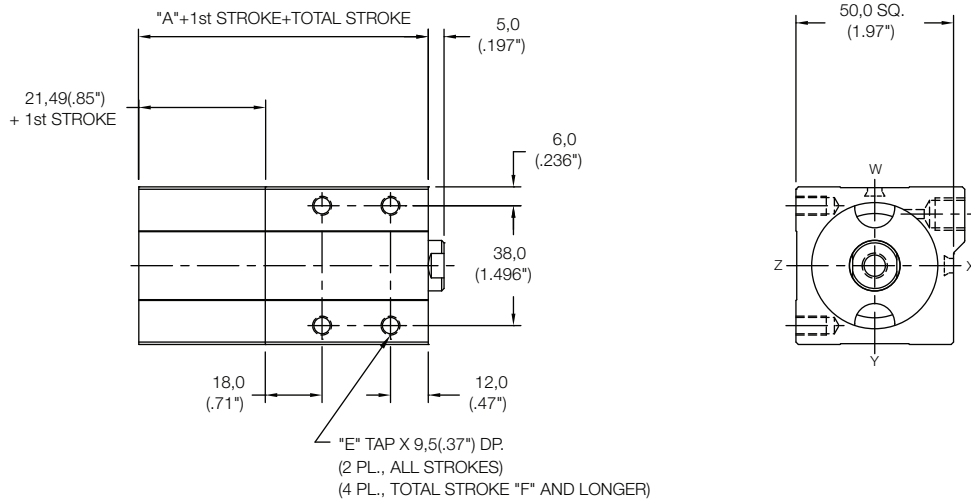

Multi-Position Cylinder Front Mount Cylinder "MF"

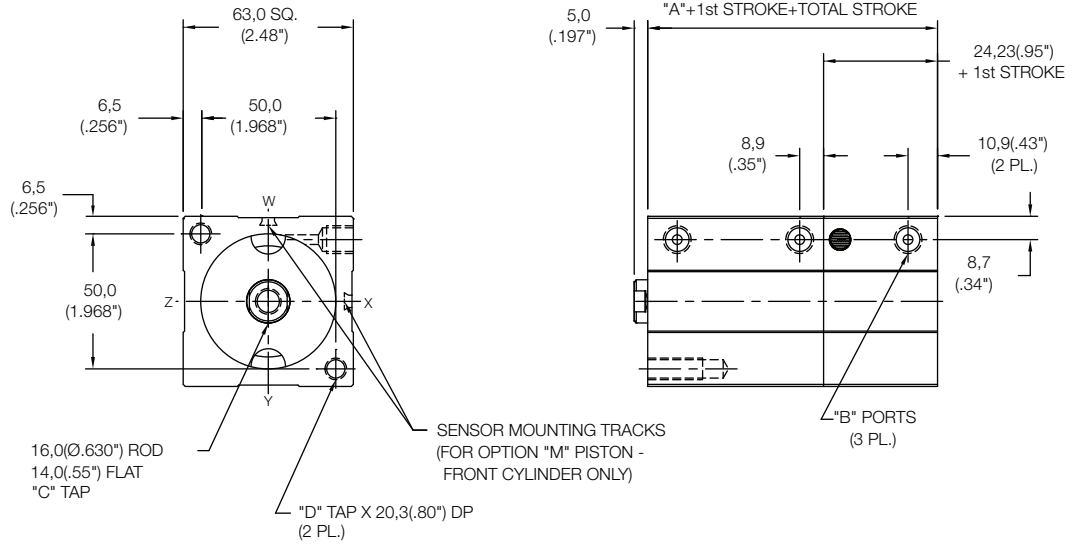

MODEL	PISTON	"A"	"F"	PISTON	"A"	"F"
PS	Non-Mag	51,0(2.01")	40,0mm(1.58")	Mag	56,0(2.20")	35,0mm(1.38")
PE	Non-Mag	61,0(2.40")	30,0mm(1.18")	Mag	66,0(2.60")	25,0mm(.98")
PH	Non-Mag	66,0(2.60")	25,0mm(.98")	Mag	71,0(2.80")	20,0mm(.79")

	Standard Threads	"EM" Option
"B"	G1/8 PORT	1/8-27
"C"	M10X1,5	3/8-24
"D"	M8X1,25	5/16-18
"E"	M8X1,25	5/16-18

Side Mount Cylinder "MS"

(All dimensions not shown same as "MF")

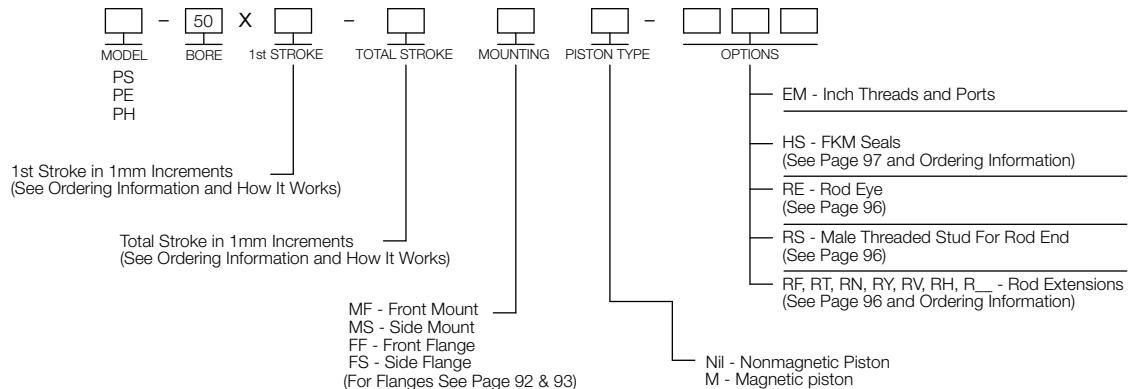
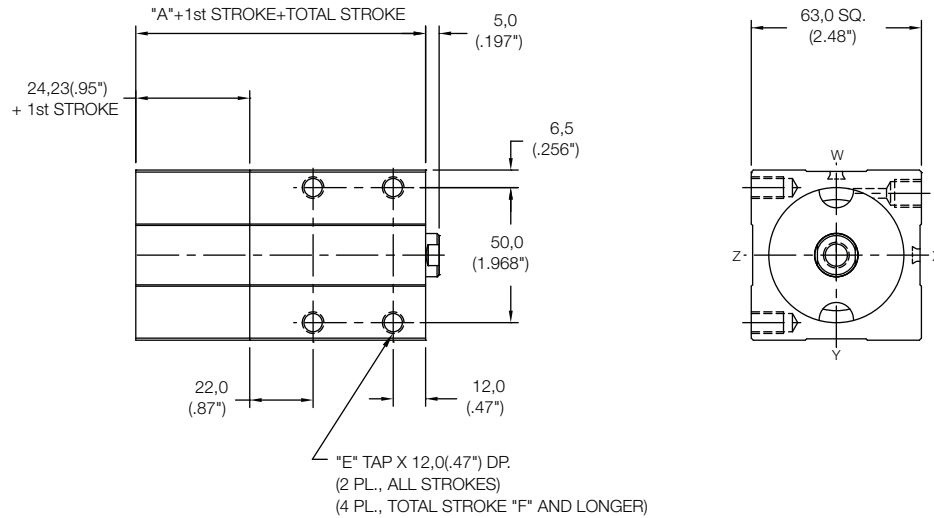

Multi-Position Cylinder Front Mount Cylinder "MF"

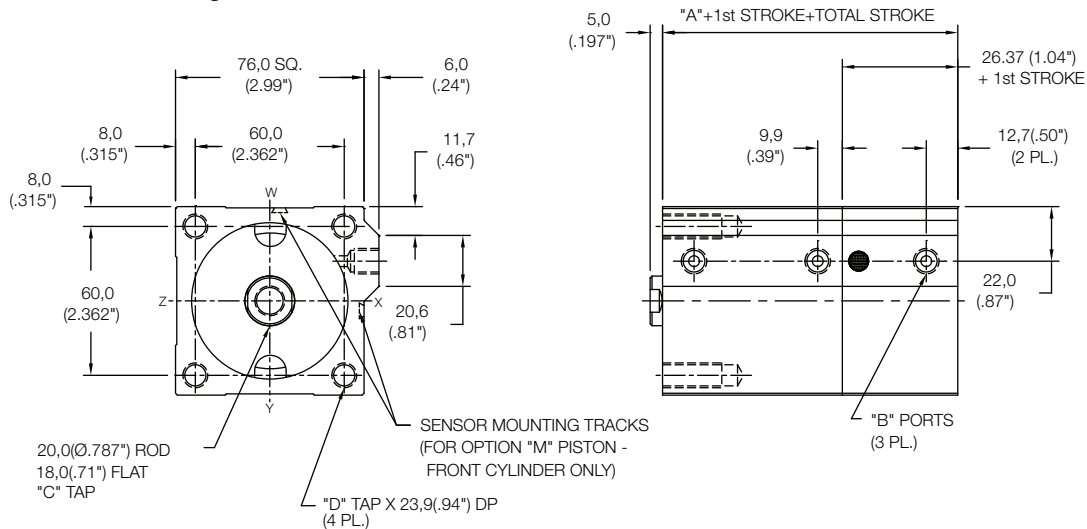

MODEL	PISTON	"A"	"F"	PISTON	"A"	"F"
PS	Non-Mag	56,0(2.20")	45,0mm(1.77")	Mag	61,0(2.40")	40,0mm(1.58")
PE	Non-Mag	66,0(2.60")	35,0mm(1.38")	Mag	71,0(2.80")	30,0mm(1.18")
PH	Non-Mag	76,0(2.99")	25,0mm(.98")	Mag	81,0(3.19")	20,0mm(.79")

	Standard Threads	"EM" Option
"B"	G1/8 PORT	1/8-27
"C"	M12X1,75	1/2-13
"D"	M10X1,5	3/8-24
"E"	M8X1,25	5/16-18

Side Mount Cylinder "MS"

(All dimensions not shown same as "MF")

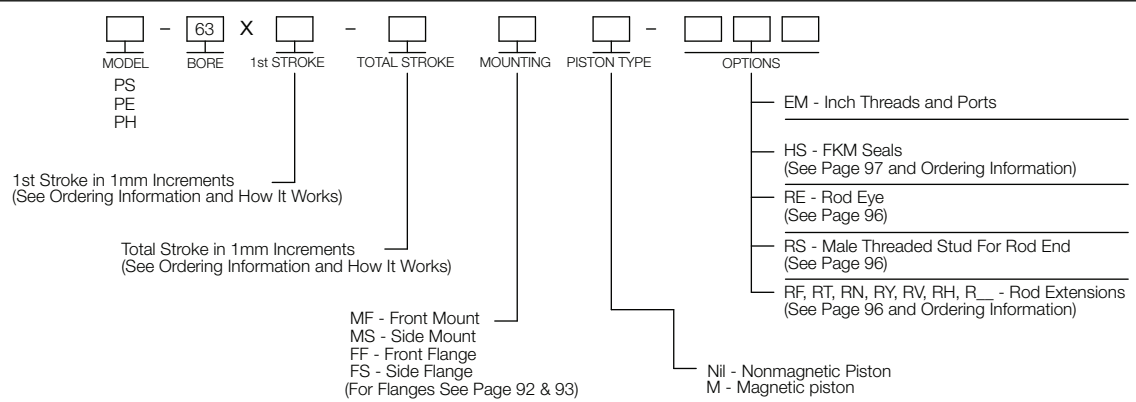
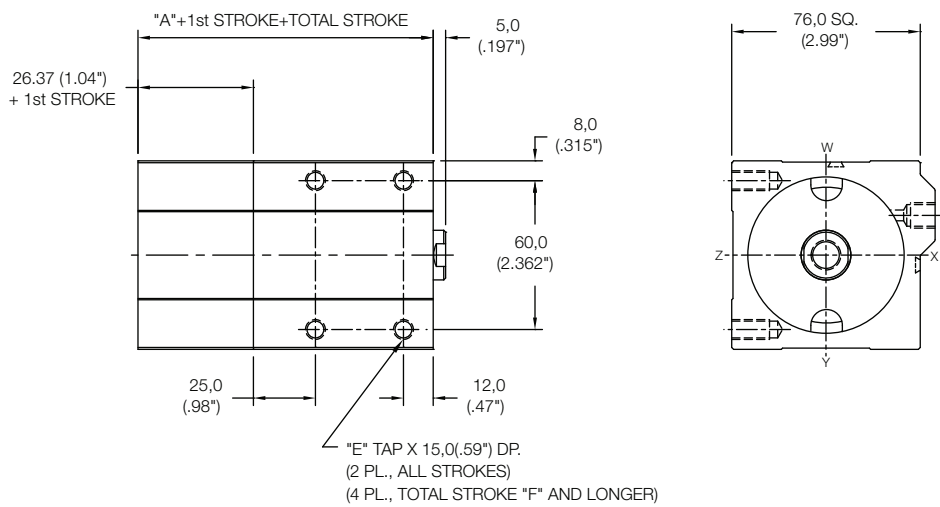

Multi-Position Cylinder Front Mount Cylinder "MF"

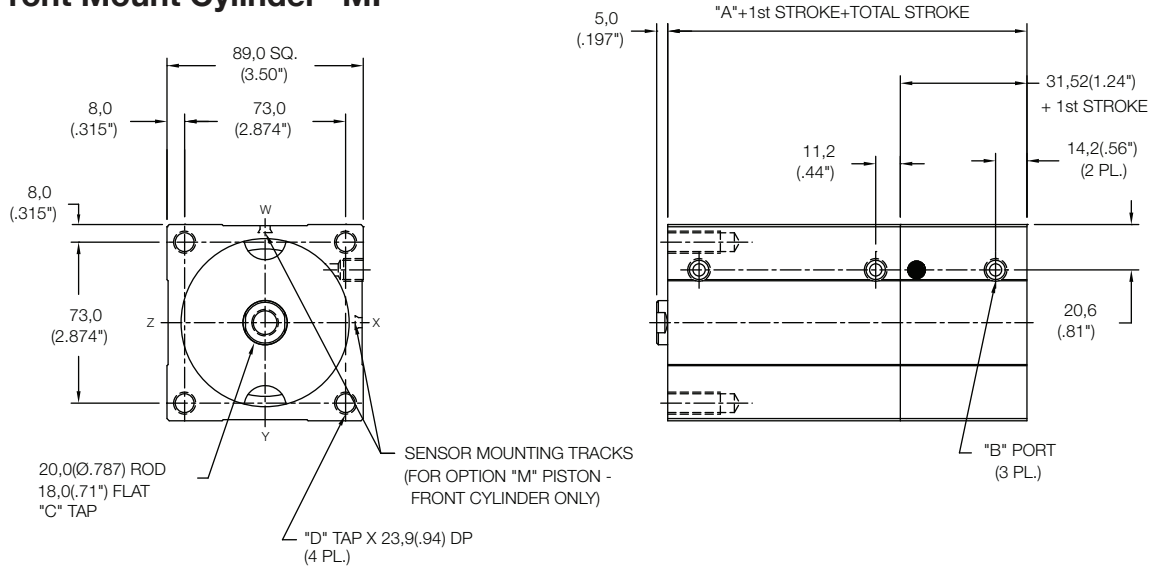

MODEL	PISTON	"A"	"F"	PISTON	"A"	"F"
PS	Non-Mag	67,0(2.64")	45,0mm(1.77")	Mag	72,0(2.83")	40,0mm(1.58")
PE	Non-Mag	77,0(3.03")	35,0mm(1.38")	Mag	82,0(3.23")	30,0mm(1.18")
PH	Non-Mag	87,0(3.43")	25,0mm(.98")	Mag	92,0(3.62")	20,0mm(.79")

	Standard Threads	"EM" Option
"B"	G1/8 PORT	1/8-27
"C"	M12X1,75	1/2-13
"D"	M10X1,5	3/8-24
"E"	M10X1,5	3/8-24

Side Mount Cylinder "MS"

(All dimensions not shown same as "MF")

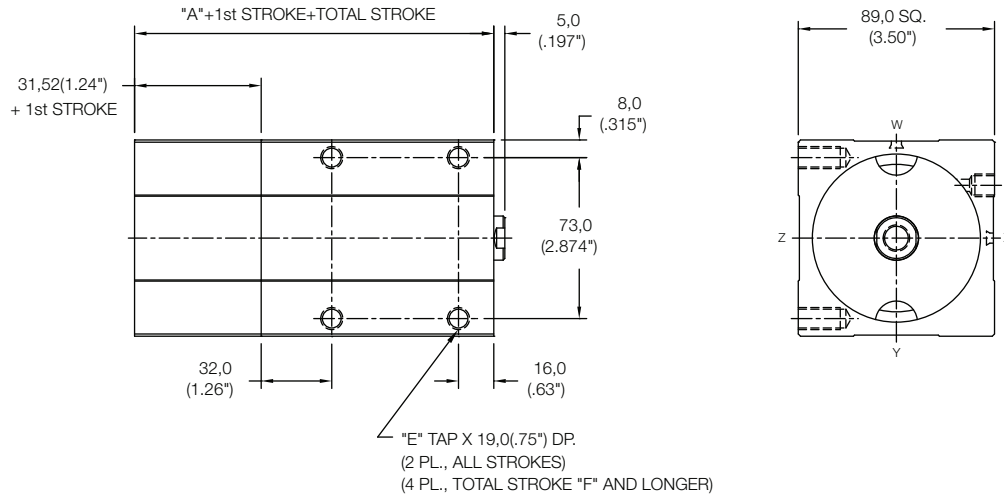

- MODEL
PS
PE
PH
- 1st Stroke in 1mm Increments
(See Ordering Information and How It Works)
- Total Stroke in 1mm Increments
(See Ordering Information and How It Works)
- MF - Front Mount
MS - Side Mount
FF - Front Flange
FS - Side Flange
(For Flanges See Page 92 & 93)
- EM - Inch Threads and Ports
- HS - FKM Seals
(See Page 97 and Ordering Information)
- RE - Rod Eye
(See Page 96)
- RS - Male Threaded Stud For Rod End
(See Page 96)
- RF, RT, RN, RY, RV, RH, R_ - Rod Extensions
(See Page 96 and Ordering Information)
- Nil - Nonmagnetic Piston
M - Magnetic piston

BS SERIES

PNEUMATIC CYLINDERS

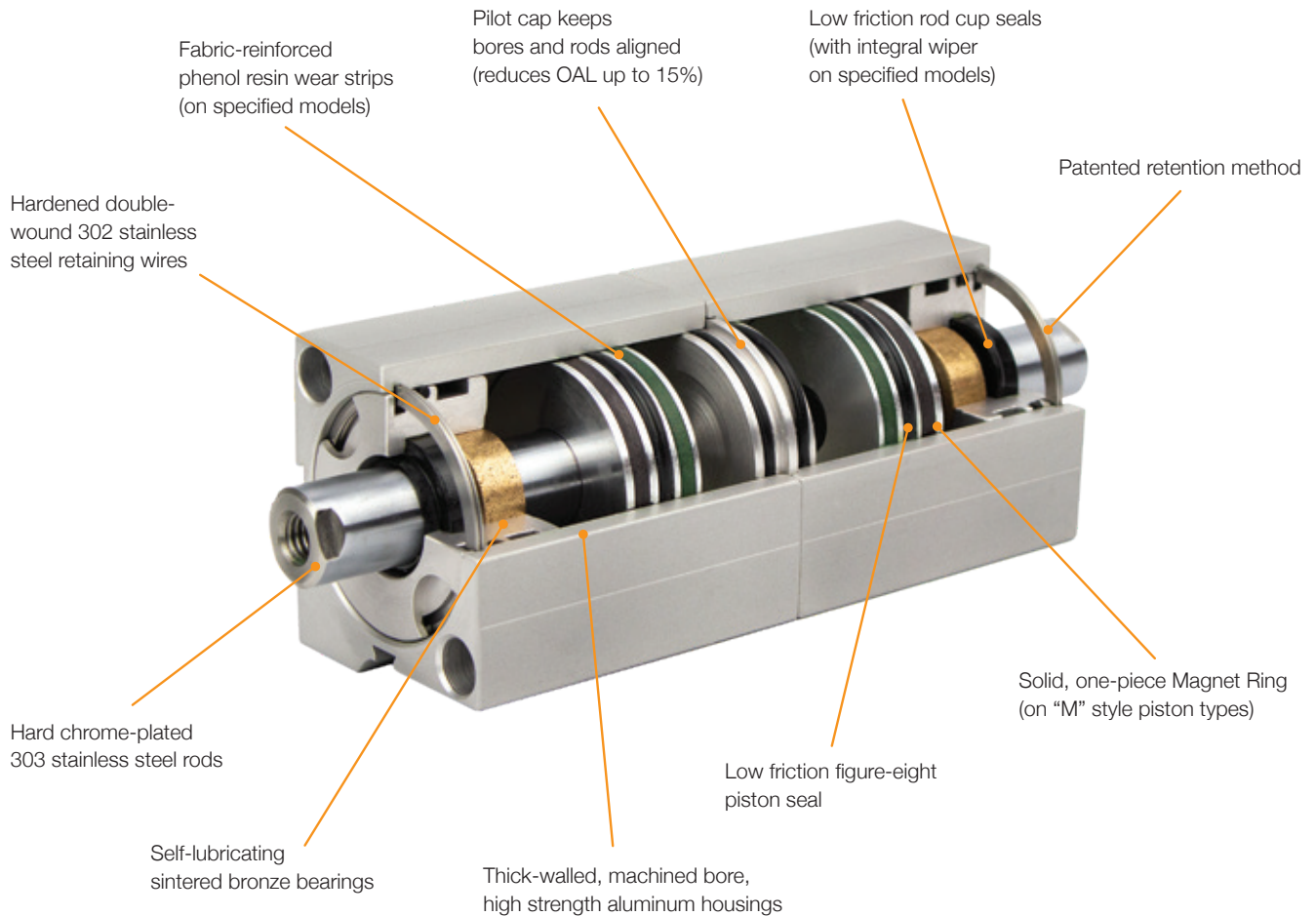

Back to Back 3 Position Pneumatic Cylinders

The B series cylinder line is based on the same rugged, proven designs of Nason's L series cylinders. Thick-walled, custom aluminum extrusions are precision bored and honed. High strength aluminum internal components are machined to exacting tolerances to control seal squeezes and stroke tolerances. Chrome-plated 303 stainless steel rods are precision ground for long life. The dual-piloted center cap keeps bores and rod ends in strict alignment. The unique design of the Back to Back series saves up to 15% of space compared to two standard units bolted together.

3 Position Back to Back Cylinder

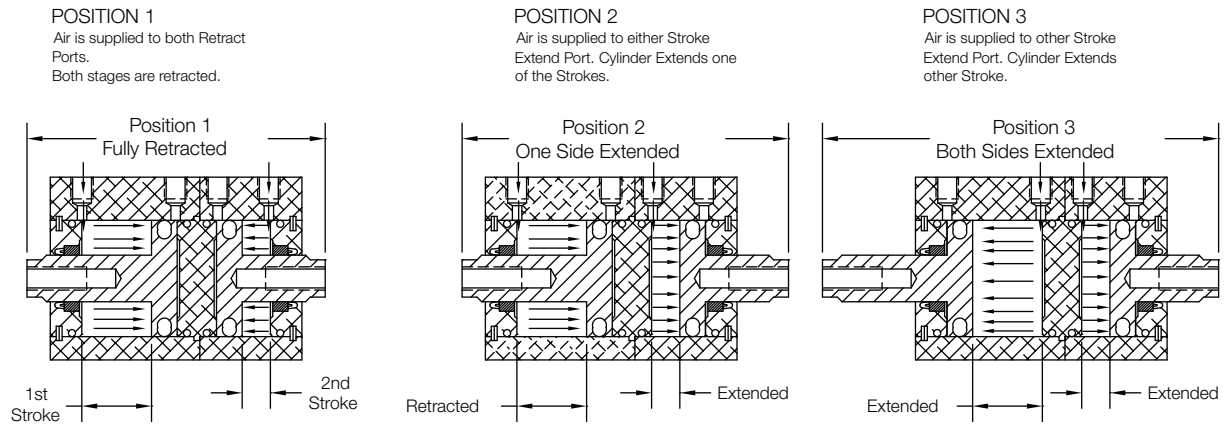

Individual Features

Model - BS

- Most compact of 3 models

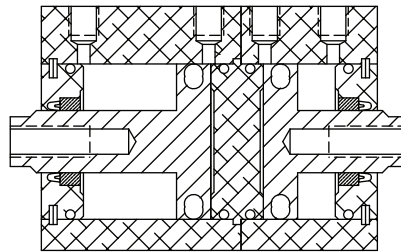

Model - BE

- Extended internal front rod bearings for additional load support
- Integral seal and rod wiper

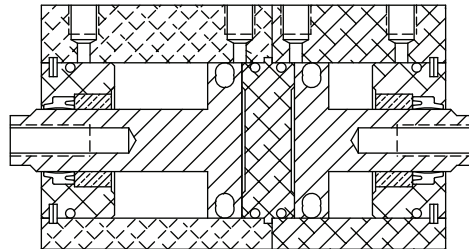

Model - BH

- Extended internal front rod bearings for additional load support
- Integral seal and rod wiper
- Wear bands added to pistons for additional load support

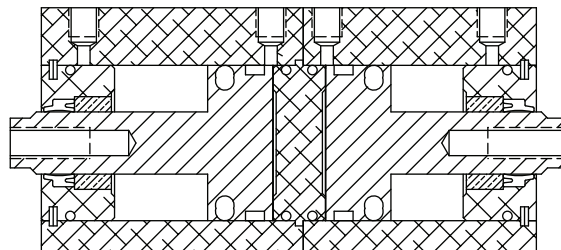

How To Order

Example: Heavy Duty, 40mm Bore, 35mm stroke + 20mm Stroke, No Mounting Holes (using rod ends), Magnetic Piston, Inch Threads, 17mm Total Rod Extension on 1st Stroke, 13mm Total Rod Extension on 2nd Stroke, Urethane Shock Pads

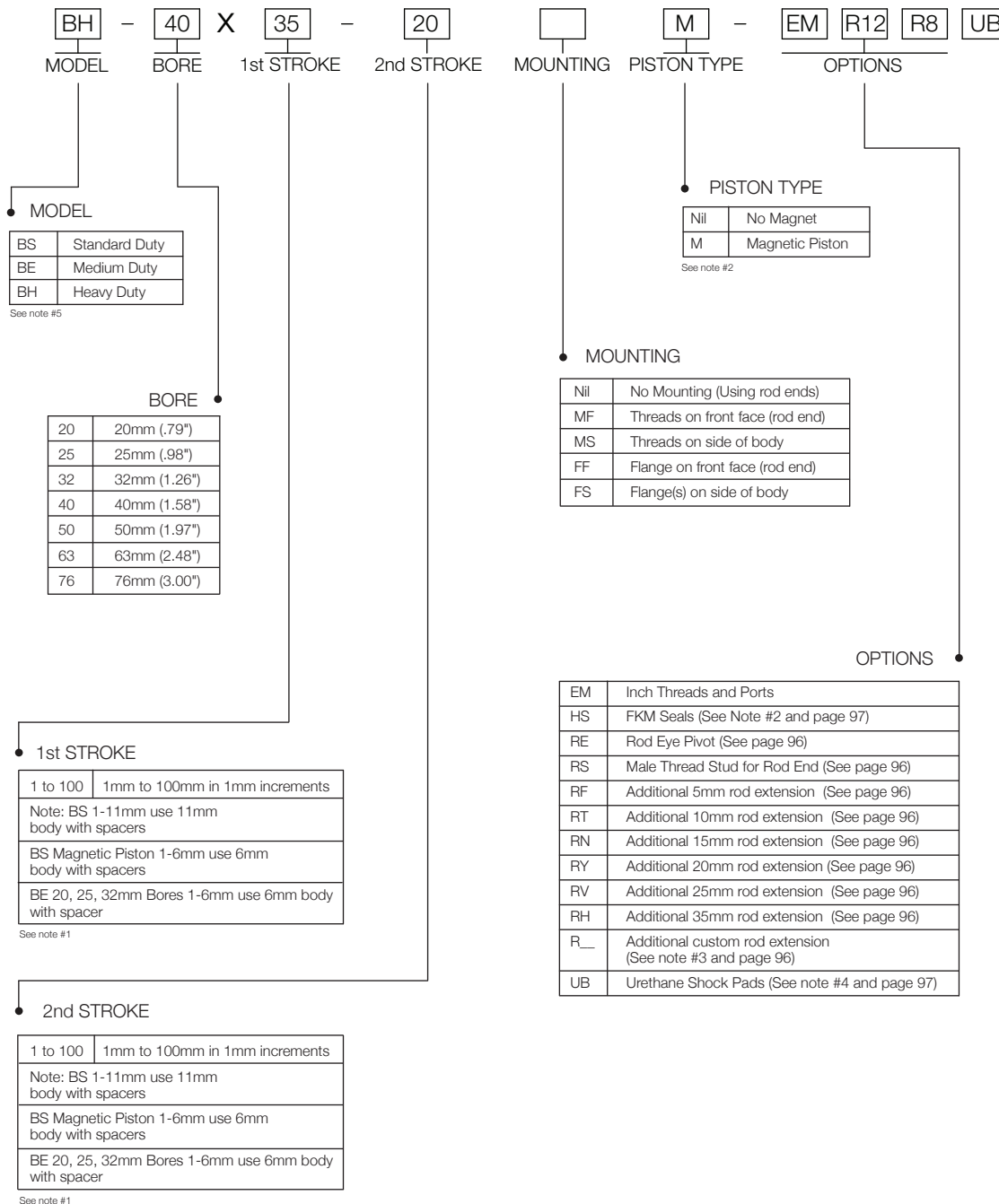

Note 1 - Model BS with a Nonmagnetic Piston uses a 11mm stroke body length for Either Stroke of 11mm or less. Either Stroke over 11mm use body length of the actual stroke + adder. Model BS with Code "M" Magnetic Piston uses a 6mm stroke body length for Either Stroke of 6mm or less. Either Stroke over 6mm use body length of the actual stroke + adder. Model BE 20, 25, & 32mm Bore with a Nonmagnetic Piston uses a 6mm stroke body length for Total Stroke of 6mm or less. Total Strokes over 6mm use body length of the actual stroke + adder. Examples: BS-20X8-3FF-EM would have a Total Length of 11+11+34(Dim"A") and a 2nd Stroke body Length of 11+16.36(2nd Stroke Length Adder). See 20mm Product Page. BS-20X15-11MS-RE would have a Total Length of 15+11+34(Dim"A") and a 2nd Stroke body length of 11+16.36(1st Stroke Length Adder). See 20mm Product Page.

All other models, bores and piston combinations use body length of of the actual stroke + adder.

Note 2 - Magnetic Piston "M" limits temperature range to -10°C to 82°C (14°F to 180°F). This temperature rating overrides ALL OTHER TEMPERATURE ratings (Standard Seals, HS Seals, etc.). Magnetic Piston and Sensor mounting tracks are provided on both Cylinders.

Note 3 - "R_" Enter desired additional Custom Length Rod extension in mm after "R". Example: BE-32X40-90MSM-EMR20.4R0 would have a TOTAL ROD EXTENSION of 25.4mm (20.4mm+Standard 5mm extension) on the 1st Stroke Cylinder and standard 5mm extension on the 2nd stroke cylinder. Example: BE-32X40-90MSM-EMR0RN would have a standard rod extension of 5mm on the 1st Stroke Cylinder and TOTAL ROD EXTENSION 20mm (15mm+Standard 5mm extension) on the 2nd stroke cylinder. Always specify BOTH rod extensions if ordering additional rod extension (even if one of the extensions is 0 (R0)).

Note 4 - "UB" Urethane Shock Pads limit temperature range to -10°C to 82°C (14°F to 180°F). This temperature rating overrides ALL OTHER TEMPERATURE ratings (Standard Seals, HS Seals, etc.). Pads are mechanically retained at the four Cap faces. "UB" OPTION CHANGES STROKE TOLERANCES TO +/-2mm.

Note 5 - While all Models are offered in all strokes, it is recommended that total strokes over 25mm use BE or BH Models for added bearing support.

Engineering Data

Bore	Piston Area Extend	Piston Area Retract	Min. Operating Pressure	Max. Operating Pressure
20	3,14 cm ² (.48 in ²)	2,64 cm ² (.40 in ²)	0.08 MPa (12 PSI)	1.4 MPa (200 PSI)
25	4,91 cm ² (.76 in ²)	4,12 cm ² (.64 in ²)	0.08 MPa (12 PSI)	1.4 MPa (200 PSI)
32	8,04 cm ² (1.25 in ²)	6,91 cm ² (1.07 in ²)	0.07 MPa (10 PSI)	1.4 MPa (200 PSI)
40	12,56 cm ² (1.95 in ²)	10,55 cm ² (1.64 in ²)	0.07 MPa (10 PSI)	1.4 MPa (200 PSI)
50	19,63 cm ² (3.04 in ²)	17,62 cm ² (2.73 in ²)	0.05 MPa (7 PSI)	1.4 MPa (200 PSI)
63	31,17 cm ² (4.83 in ²)	28,03 cm ² (4.34 in ²)	0.05 MPa (7 PSI)	1.4 MPa (200 PSI)
76	45,60 cm ² (7.07 in ²)	42,46 cm ² (6.59 in ²)	0.05 MPa (7 PSI)	1.4 MPa (200 PSI)

Specifications

Action	Double Acting, 3 Position
Media	Air - Clean, Dry Or Lubricated
Pre-Lubricated at Factory	Non-soap elastomer/PTFE thickener
Temp. Range (Std.)	-10°C to 93°C (14°F to 200°F)
Temp. Range (Mag. Piston)	-10°C to 82°C (14°F to 180°F) See Note 2 & 3
Temp. Range (UB Option)	-10°C to 82°C (14°F to 180°F) See Note 2 & 3
Temp. Range (HS Option)	-10°C to 150°C (14°F to 302°F) See Note 2 & 3
Stroke Tolerance (Std)	+1,0mm/-0 (+0.04"/-0)
Stroke Tolerance (UB)	+/-2mm (+/- .08")

Available Strokes

First Stroke (See Note 1)	1mm to 100mm in 1mm increments
Second Stroke (See Note 1)	1mm to 100mm in 1mm increments

Note 1 - Model BS with a Nonmagnetic Piston uses a 11mm stroke body length for Either Stroke of 11mm or less. Either Stroke over 11mm use body length of the actual stroke + adder.
 Model BS with Code "M" Magnetic Piston uses a 6mm stroke body length for Either Stroke of 6mm or less. Either Stroke over 6mm use body length of the actual stroke + adder.
 Model BE 20, 25, & 32mm Bore with a Nonmagnetic Piston uses a 6mm stroke body length for Total Stroke of 6mm or less. Total Strokes over 6mm use body length of the actual stroke + adder.
 All other models, bores and piston combinations use body length of of the actual stroke + adder.

Note 2 - Magnetic Piston "M" limits temperature range to -10°C to 82°C (14°F to 180°F). This temperature rating overrides ALL OTHER TEMPERATURE ratings (Standard Seals, HS Seals, etc.). Magnetic Piston and Sensor mounting tracks are provided on Front (Total Stroke) Cylinder only.

Note 3 - "UB" Urethane Shock Pads limit temperature range to -10°C to 82°C (14°F to 180°F). This temperature rating overrides ALL OTHER TEMPERATURE ratings (Standard Seals, HS Seals, etc.). Pads are mechanically retained at the four Cap faces. "UB" OPTION CHANGES STROKE TOLERANCES TO +/-2mm.

Note 4 - While all Models are offered in all strokes, it is recommended that total strokes over 25mm use BE or BH Models for added bearing support.

**Back to Back Cylinder
Front Mount Cylinder "MF"**

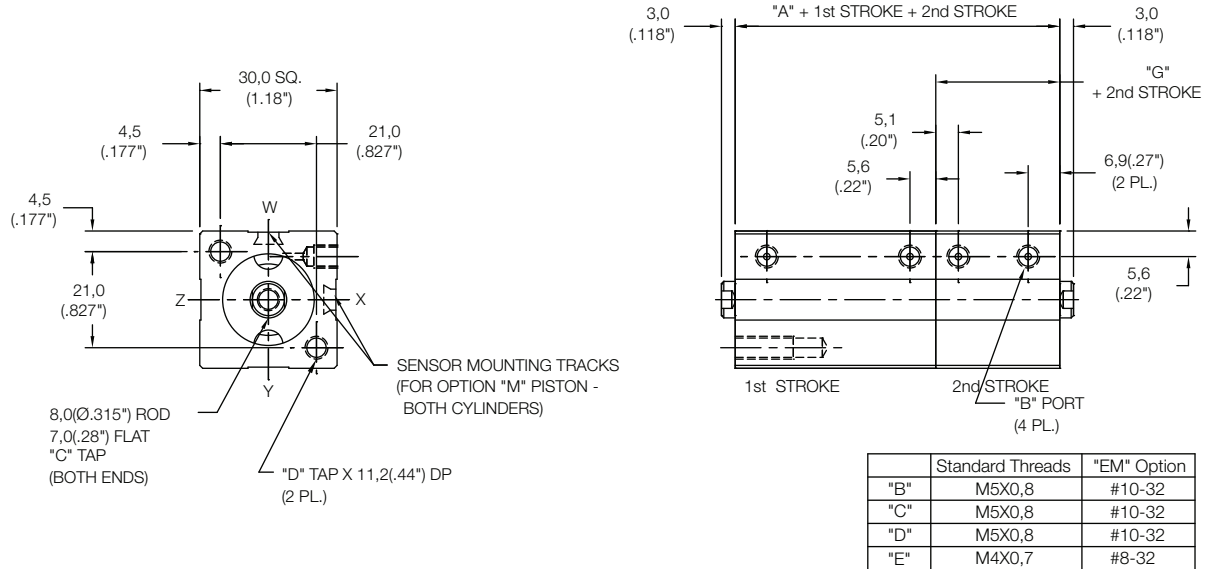

MODEL	PISTON	"A"	"F"	"G"	PISTON	"A"	"F"	"G"
BS	Non-Mag	34,0(1.34")	40,0mm(1.58")	16,36(.64")	Mag	44,0(1.73")	35,0mm(1.38")	21,36(.84")
BE	Non-Mag	44,0(1.73")	35,0mm(1.38")	21,36(.84")	Mag	54,0(2.13")	30,0mm(1.18")	26,36(1.04")
BH	Non-Mag	54,0(2.13")	30,0mm(1.18")	26,36(1.04")	Mag	64,0(2.52")	25,0mm(.98")	31,36(1.23")

Side Mount Cylinder "MS"

(All dimensions not shown same as "MF")

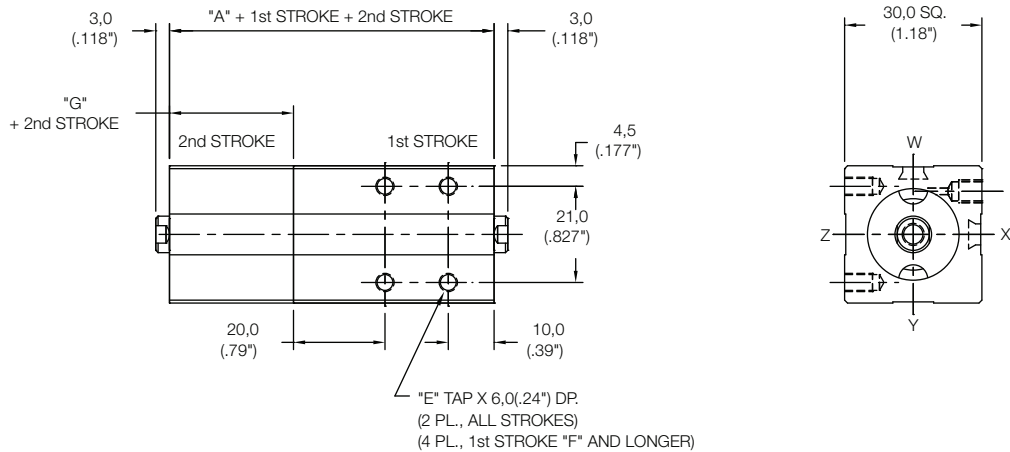

- MODEL: BS, BE, BH
- 1st Stroke in 1mm Increments (Must be the longest of the 2 strokes) (See Ordering Information and How It Works)
- 2nd Stroke in 1mm Increments (Must be the shortest of the 2 strokes) (See Ordering Information and How It Works)
- Mounting: Nil - No Mounts (Mounting with rod ends), MF - Front Mount, MS - Side Mount, FF - Front Flange, FS - Side Flange (For Flanges See Page 92 & 93) (Mounting is always on 1st stroke Cylinder)
- Piston Type: Nil - Nonmagnetic Piston, M - Magnetic piston
- Options: EM - Inch Threads and Ports, HS - FKM Seals (See Page 97 and Ordering Information), RE - Rod Eye (See Page 96), RS - Male Threaded Stud For Rod End (See Page 96), RF, RT, RN, RY, RV, RH, R_ - Rod Extensions (See Page 96 and Ordering Information)

Back to Back Cylinder Front Mount Cylinder "MF"

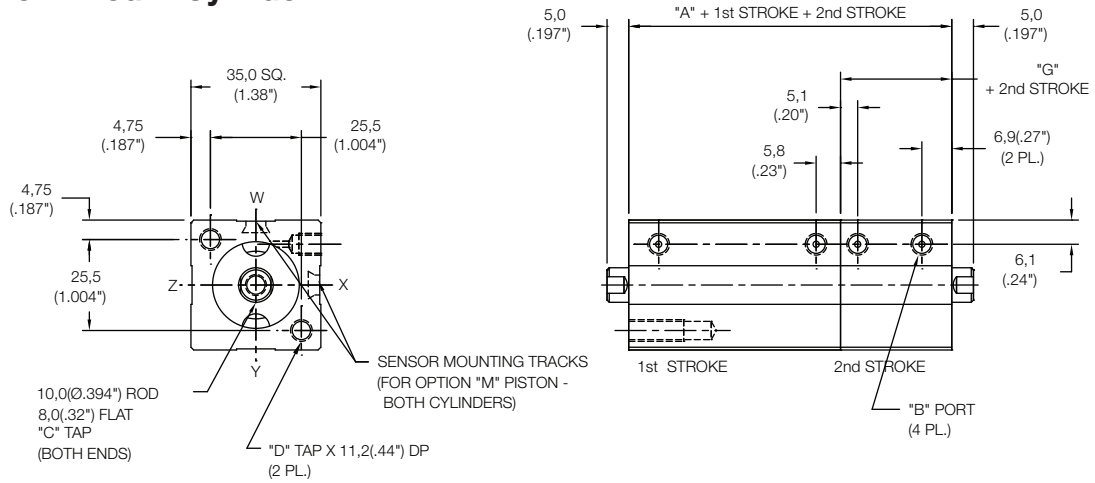

MODEL	PISTON	"A"	"F"	"G"	PISTON	"A"	"F"	"G"
BS	Non-Mag	35,0(1.38")	40,0mm(1.58")	16,82(.66")	Mag	45,0(1.77")	35,0mm(1.38")	21,82(.86")
BE	Non-Mag	45,0(1.77")	35,0mm(1.38")	21,82(.86")	Mag	55,0(2.17")	30,0mm(1.18")	26,82(1.06")
BH	Non-Mag	55,0(2.17")	30,0mm(1.18")	26,82(1.06")	Mag	65,0(2.56")	25,0mm(.98")	31,82(1.25")

	Standard Threads	"EM" Option
"B"	M5X0,8	#10-32
"C"	M5X0,8	#10-32
"D"	M5X0,8	#10-32
"E"	M5X0,8	#10-32

Side Mount Cylinder "MS"

(All dimensions not shown same as "MF")

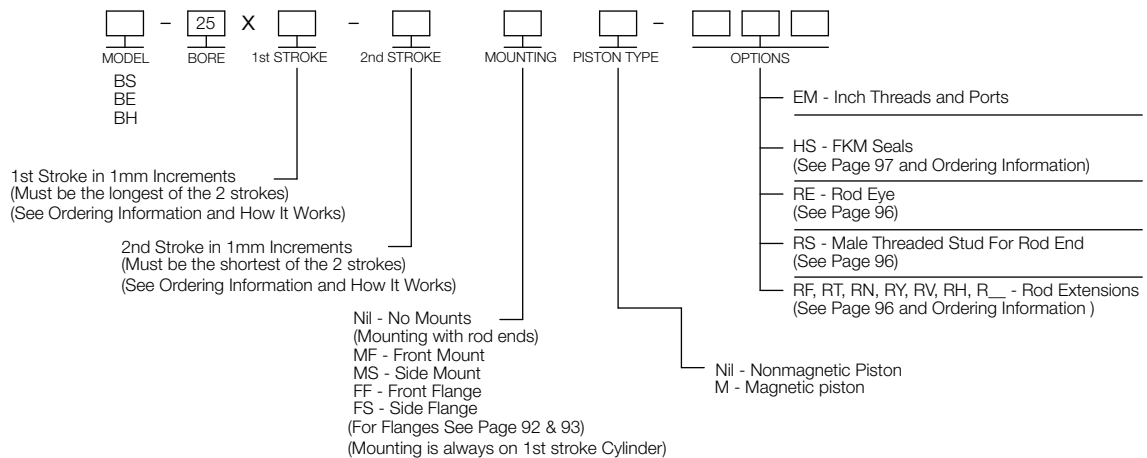
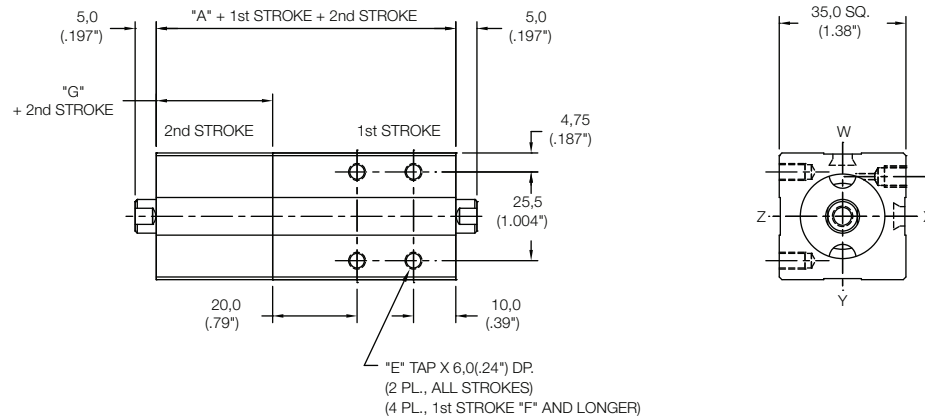

**Back to Back Cylinder
Front Mount Cylinder "MF"**

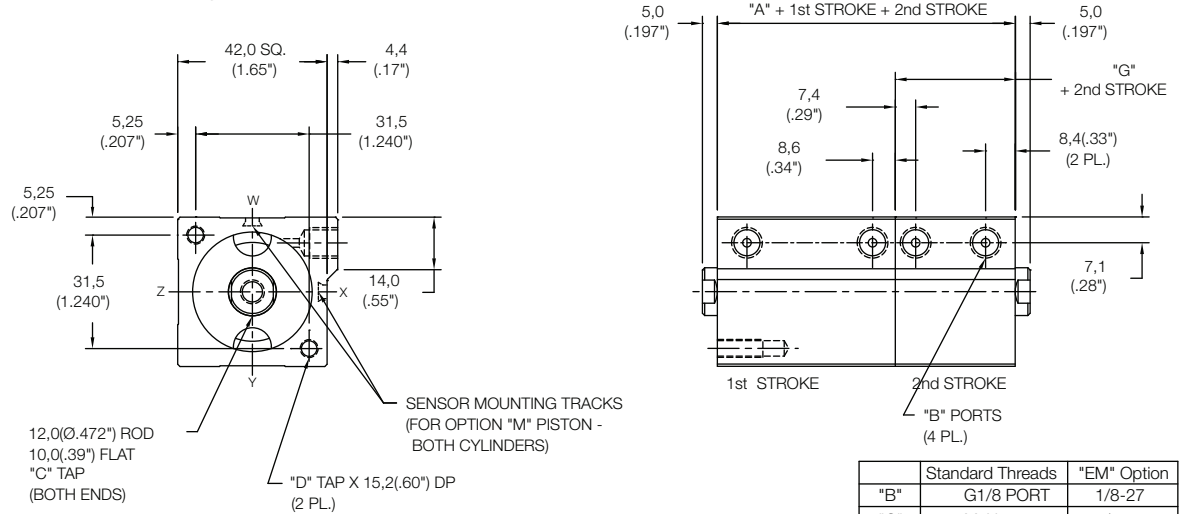

MODEL	PISTON	"A"	"F"	"G"	PISTON	"A"	"F"	"G"
BS	Non-Mag	41,0(1.61")	40,0mm(1.58")	19,63(.77")	Mag	51,0(2.01")	35,0mm(1.38")	24,63(.97")
BE	Non-Mag	51,0(2.01")	35,0mm(1.38")	24,63(.97")	Mag	61,0(2.40")	30,0mm(1.18")	29,63(1.17")
BH	Non-Mag	61,0(2.40")	30,0mm(1.18")	29,63(1.17")	Mag	71,0(2.80")	25,0mm(.98")	34,63(1.36")

Side Mount Cylinder "MS"

(All dimensions not shown same as "MF")

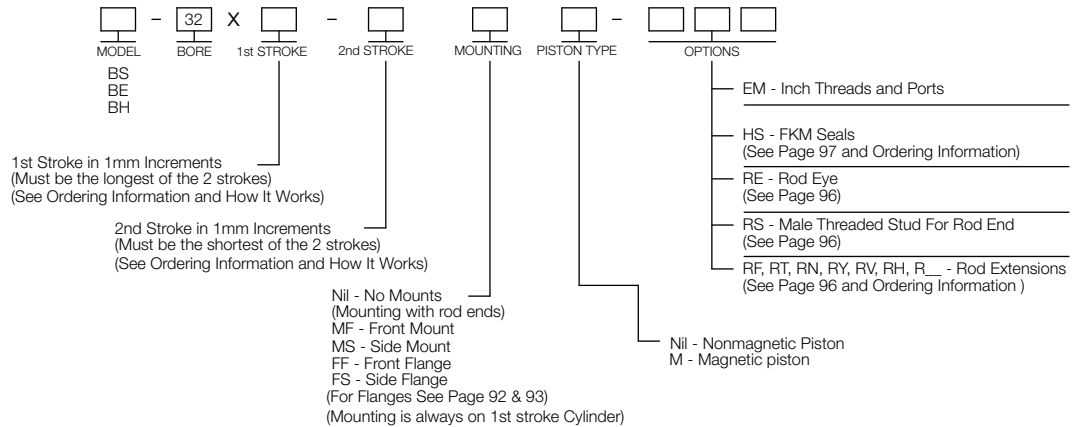
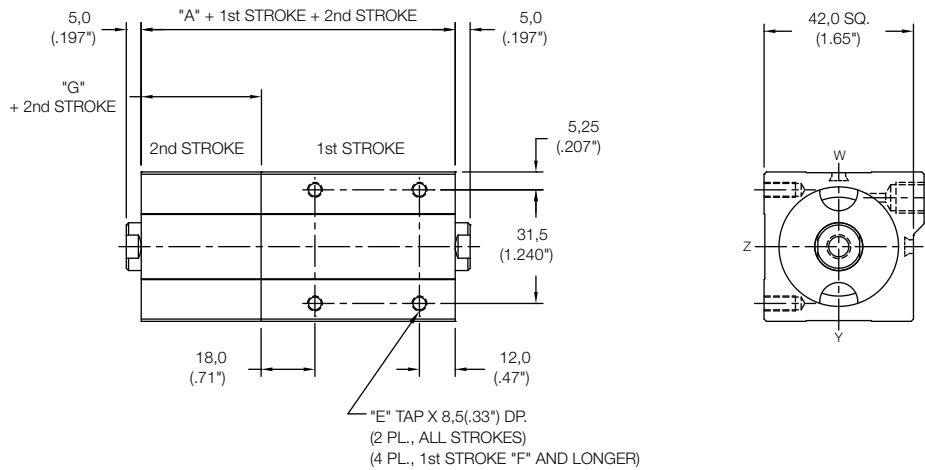

**Back to Back Cylinder
Front Mount Cylinder "MF"**

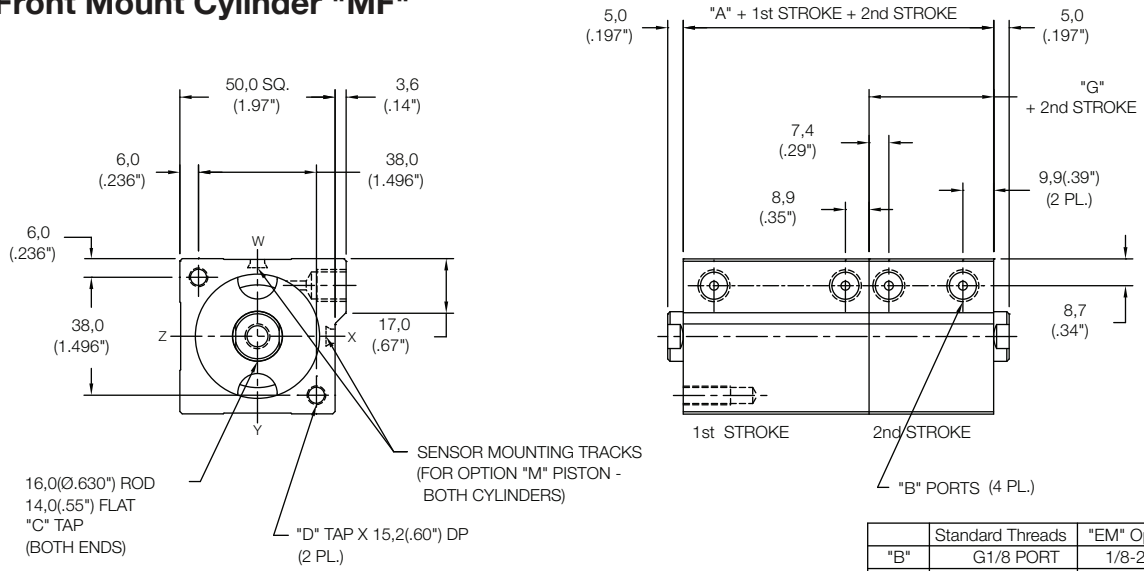

	Standard Threads	"EM" Option
"B"	G1/8 PORT	1/8-27
"C"	M8X1,25	5/16-18
"D"	M6X1,0	1/4-20
"E"	M6X1,0	1/4-20

MODEL	PISTON	"A"	"F"	"G"	PISTON	"A"	"F"	"G"
BS	Non-Mag	45,0(1.77")	40,0mm(1.58")	21,49(.85")	Mag	55,0(2.17")	35,0mm(1.38")	26,49(1.04")
BE	Non-Mag	65,0(2.56")	30,0mm(1.18")	31,49(1.24")	Mag	75,0(2.95")	25,0mm(.98")	36,49(1.44")
BH	Non-Mag	75,0(2.95")	25,0mm(.98")	36,49(1.44")	Mag	85,0(3.35")	20,0mm(.79")	41,49(1.63")

Side Mount Cylinder "MS"

(All dimensions not shown same as "MF")

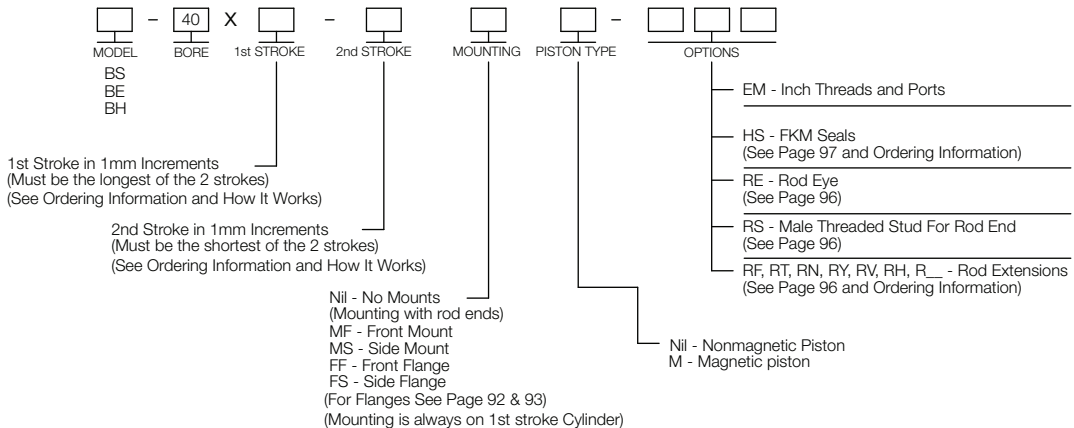
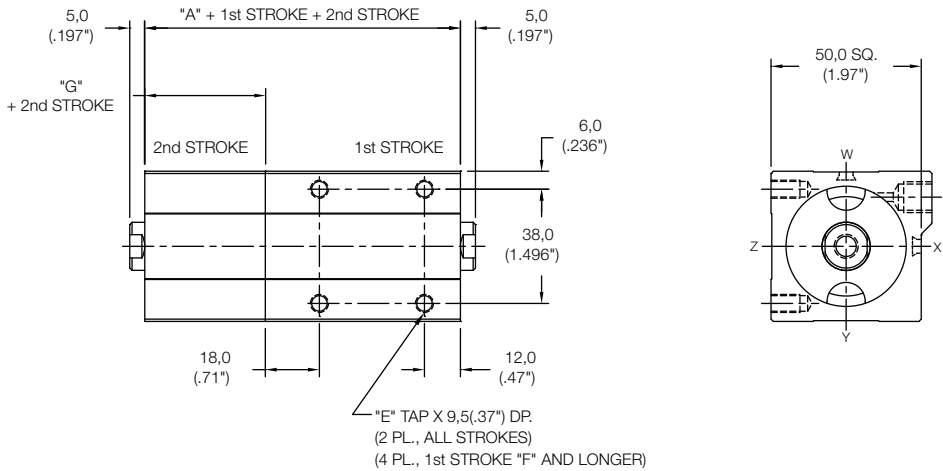

**Back to Back Cylinder
Front Mount Cylinder "MF"**

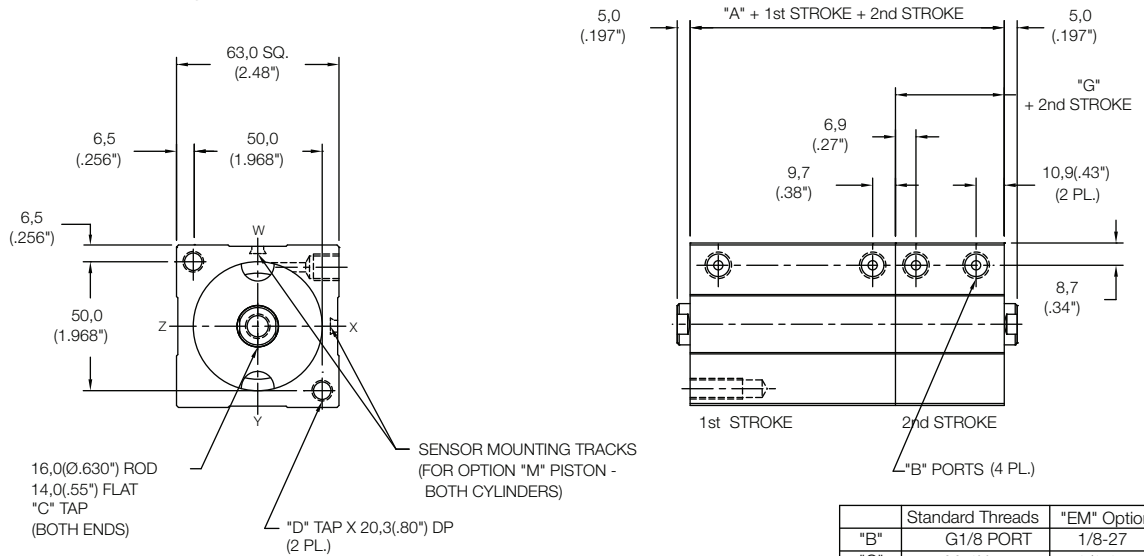

	Standard Threads	"EM" Option
"B"	G1/8 PORT	1/8-27
"C"	M10X1,5	3/8-24
"D"	M8X1,25	5/16-18
"E"	M8X1,25	5/16-18

MODEL	PISTON	"A"	"F"	"G"	PISTON	"A"	"F"	"G"
BS	Non-Mag	51,0(2.01")	40,0mm(1.58")	24,23 (.95")	Mag	61,0(2.40")	35,0mm(1.38")	29,23 (1.15")
BE	Non-Mag	71,0(2.80")	30,0mm(1.18")	34,23 (1.35")	Mag	81,0(3.19")	25,0mm(.98")	39,23 (1.54")
BH	Non-Mag	81,0(3.19")	25,0mm(.98")	39,23 (1.54")	Mag	91,0(3.58")	20,0mm(.79")	44,23 (1.74")

Side Mount Cylinder "MS"

(All dimensions not shown same as "MF")

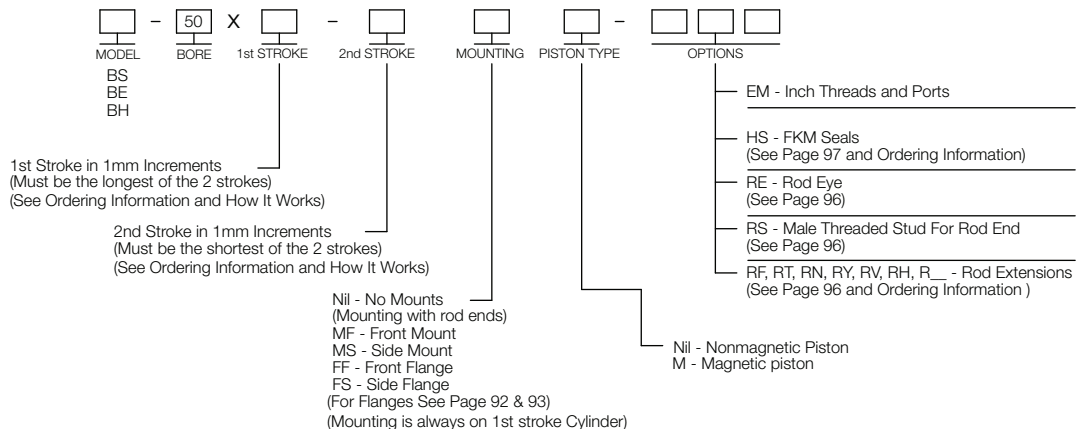
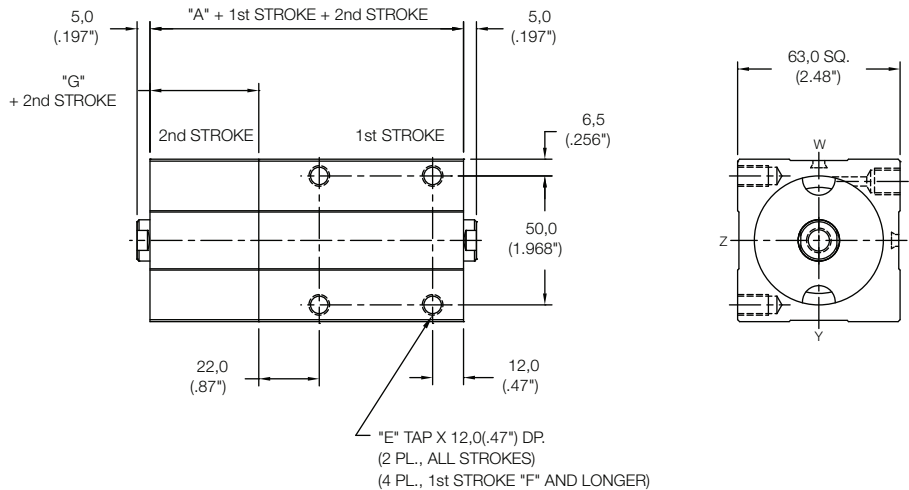

**Back to Back Cylinder
Front Mount Cylinder "MF"**

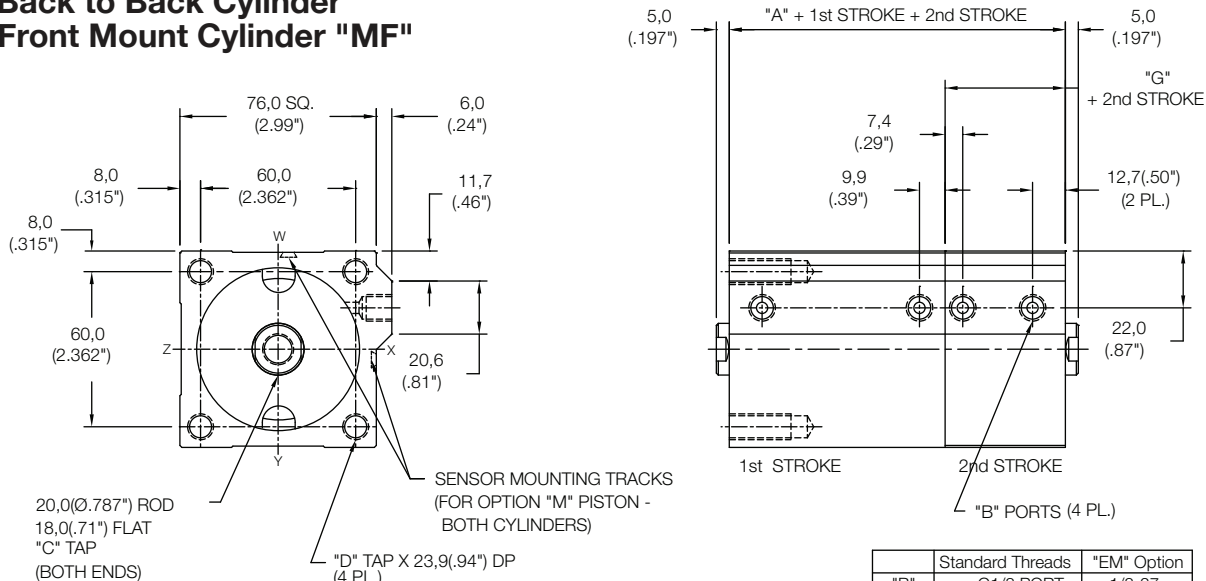

	Standard Threads	"EM" Option
"B"	G1/8 PORT	1/8-27
"C"	M12X1,75	1/2-13
"D"	M10X1,5	3/8-24
"E"	M8X1.25	5/16-18

MODEL	PISTON	"A"	"F"	"G"	PISTON	"A"	"F"	"G"
BS	Non-Mag	56,0(2.20")	45,0mm(1.77")	26,37(1.04")	Mag	66,0(2.60")	40,0mm(1.58")	31,37(1.24")
BE	Non-Mag	76,0(2.99")	35,0mm(1.38")	36,37(1.43")	Mag	86,0(3.39")	30,0mm(1.18")	41,37(1.63")
BH	Non-Mag	96,0(3.78")	25,0mm(.98")	46,37(1.83")	Mag	106,0(4.17")	20,0mm(.79")	51,37(2.02")

Side Mount Cylinder "MS"

(All dimensions not shown same as "MF")

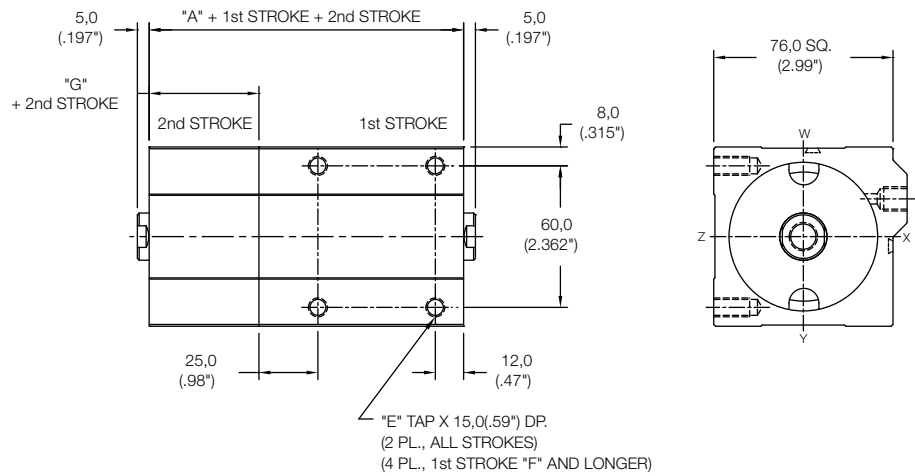

1st Stroke in 1mm Increments
(Must be the longest of the 2 strokes)
(See Ordering Information and How It Works)

2nd Stroke in 1mm Increments
(Must be the shortest of the 2 strokes)
(See Ordering Information and How It Works)

Nil - No Mounts
(Mounting with rod ends)
MF - Front Mount
MS - Side Mount
FF - Front Flange
FS - Side Flange
(For Flanges See Page 92 & 93)
(Mounting is always on 1st stroke Cylinder)

EM - Inch Threads and Ports
HS - FKM Seals
(See Page 97 and Ordering Information)
RE - Rod Eye
(See Page 96)
RS - Male Threaded Stud For Rod End
(See Page 96)
RF, RT, RN, RY, RV, RH, R_ - Rod Extensions
(See Page 96 and Ordering Information)

Nil - Nonmagnetic Piston
M - Magnetic piston

**Back to Back Cylinder
Front Mount Cylinder "MF"**

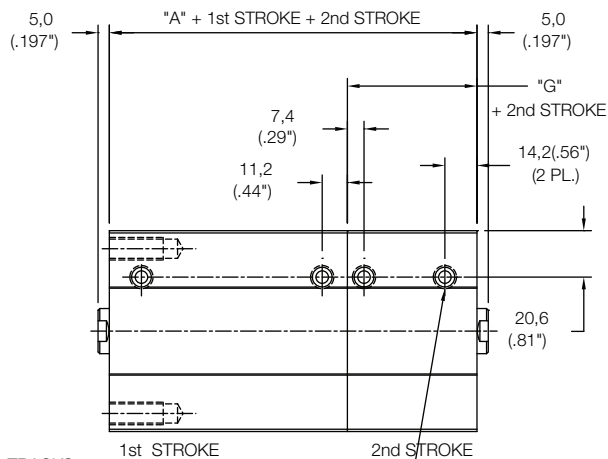
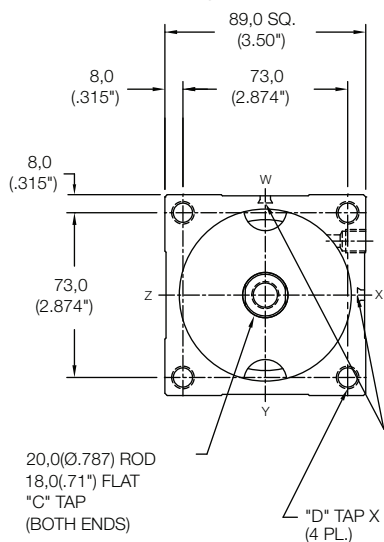

20.0(Ø.787) ROD
18.0(.71") FLAT
"C" TAP
(BOTH ENDS)

"D" TAP X 23.9(.94) DP
(4 PL.)

SENSOR MOUNTING TRACKS
(FOR OPTION "M" PISTON -
BOTH CYLINDERS)

	Standard Threads	"EM" Option
"B"	G1/8 PORT	1/8-27
"C"	M12X1.75	1/2-13
"D"	M10X1.5	3/8-24
"E"	M10X1.5	3/8-24

MODEL	PISTON	"A"	"F"	"G"	PISTON	"A"	"F"	"G"
BS	Non-Mag	67,0(2.64")	45,0mm(1.77")	31,52(1.24")	Mag	77,0(3.03")	40,0mm(1.58")	36,52(1.44")
BE	Non-Mag	87,0(3.43")	35,0mm(1.38")	41,52(1.63")	Mag	97,0(3.82")	30,0mm(1.18")	46,52(1.83")
BH	Non-Mag	107,0(4.21")	25,0mm(.98")	51,52(2.03")	Mag	117,0(4.61")	20,0mm(.79")	56,52(2.23")

Side Mount Cylinder "MS"

(All dimensions not shown same as "MF")

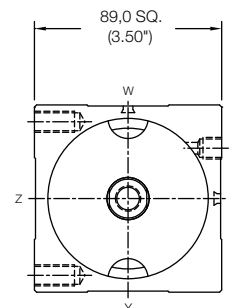
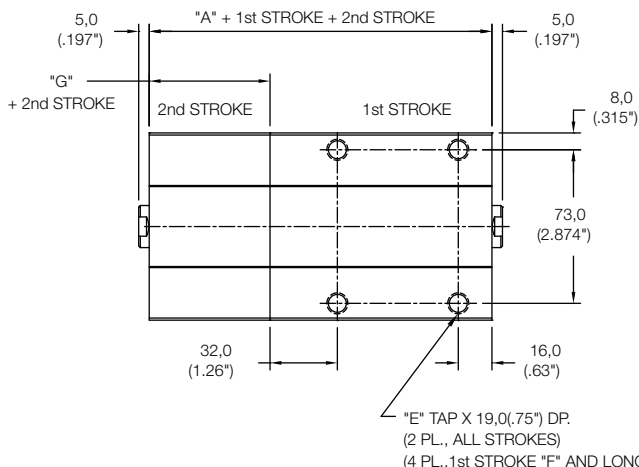

"E" TAP X 19.0(.75") DP.
(2 PL., ALL STROKES)
(4 PL., 1st STROKE "F" AND LONGER)

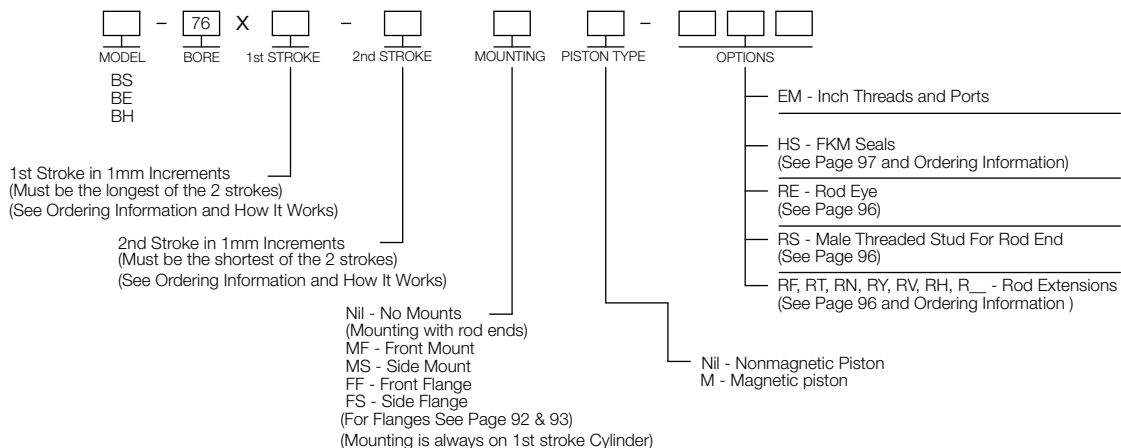

ACCESSORIES

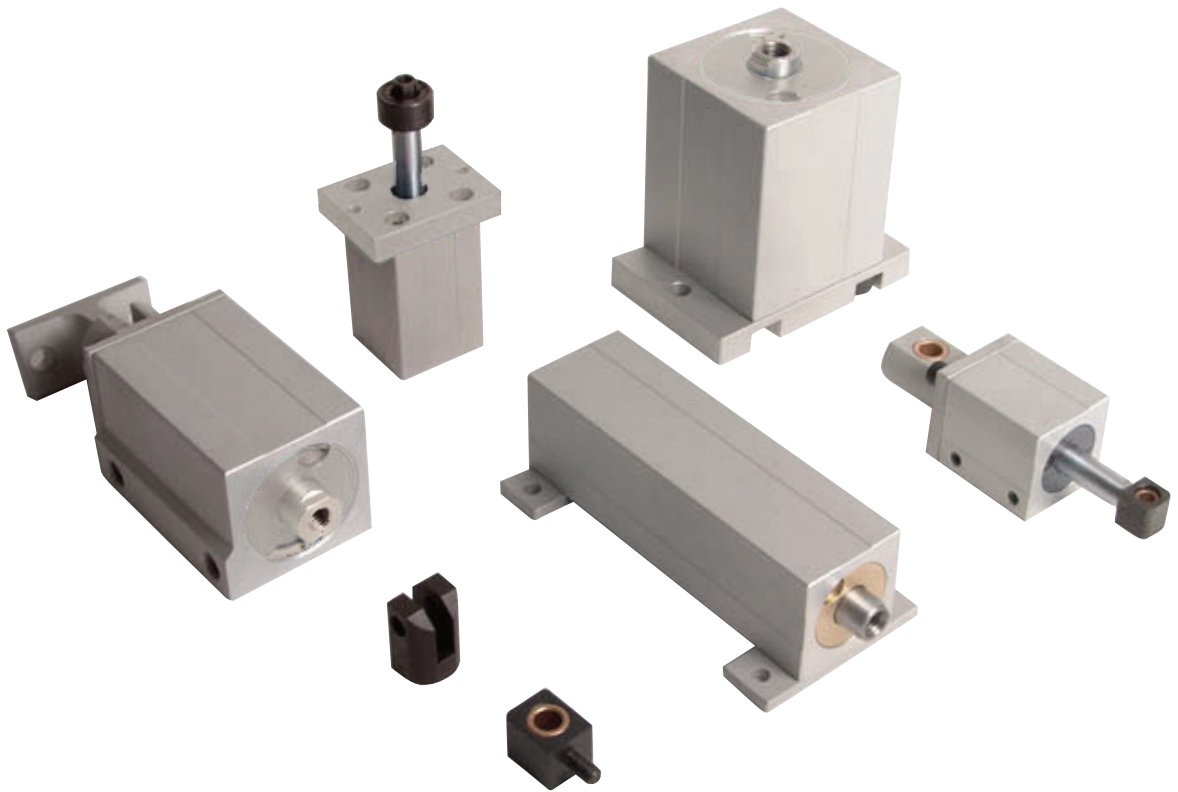

Solid State Limit Sensors

Nason limit sensors are magnetically activated digital output devices. They are on/off devices used to sense piston location on Nason "L" series cylinders. A magnet is added to the piston of the cylinder and a 60° dovetail is machined into the cylinder body to allow the sensors to be added. Magneto-resistive technology (similar to Hall Effect) is used to produce the sensors. This results in greater sensitivity and reduced dead-band compared to Hall devices.

Specifications		
Part Number	SKS, SKP	SCS, SCP
Switch Logic	Solid State Output, Normally Open	Solid State Output, Normally Open
Sensor Type	NPN, Current Sinking	PNP, Current Sourcing
Operating Voltage	5-28 VDC	
Switching Current	200mA max.	
Voltage Drop	1.0 V max	
Switching Power	4.8 Watts max.	
LED Indicator: Switch Active	Red	
Operating Temperature	-20°C to 80°C (-4°F to 176°F)	
Switching Speed	4 uS operate, 4 uS release	
Enclosure Classification	IP67, NEMA 6	
Cable	2.6 dia, 3C, 26 AWG, Black PVC	
Housing	Glass-filled Polypropylene	
Shock	50 G max	
Vibration	9 G max	

Flying Lead Sensors - Part #: SKS, SCS

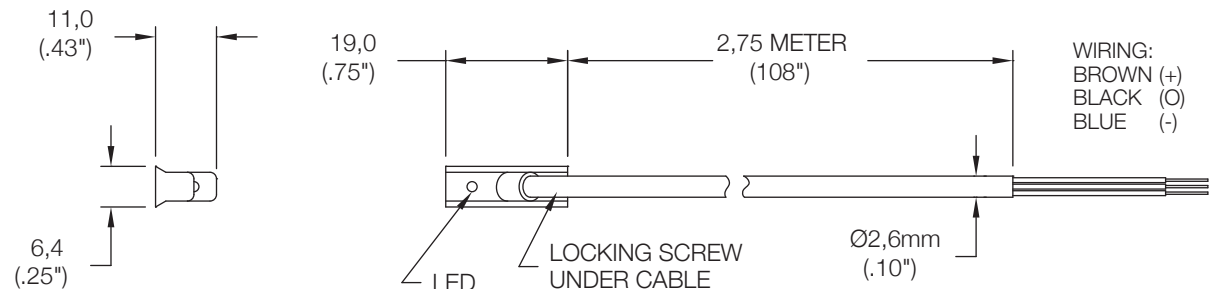

Quick Disconnect Sensors - Part #: SKP, SCP

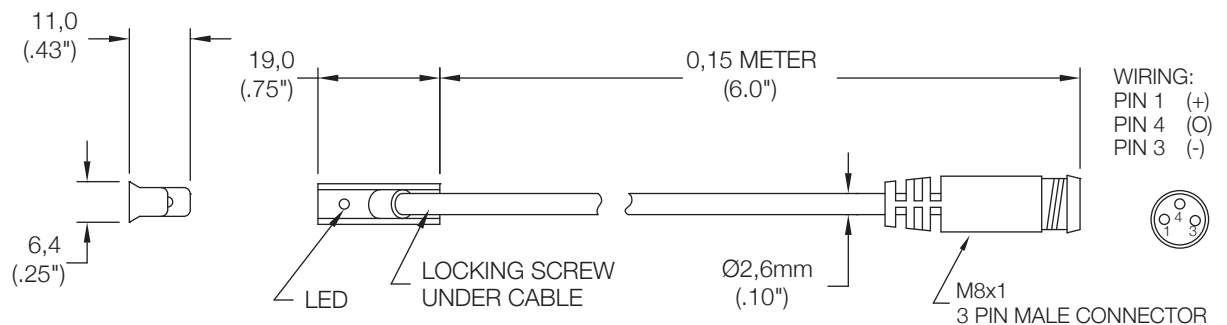

Mates with Part Number "SR" sensor receptacle. See page 90.

OBSOLETE

Low Profile Solid State Limit Sensors

Nason limit sensors are magnetically activated digital output devices. They are on/off devices used to sense piston location on Nason "C" series cylinders. A magnet is added to the piston of the cylinder and a dovetail is machined into the cylinder body to allow the sensors to be added. Magneto-resistive technology (similar to Hall Effect) is used to produce the sensors. This results in greater sensitivity and reduced dead-band compared to Hall devices.

Specifications		
Part Number	NPL, NPP	PNL, PNP
Switch Logic	Solid State Output, Normally Open	Solid State Output, Normally Open
Sensor Type	NPN, Current Sinking	PNP, Current Sourcing
Operating Voltage	5-28 VDC	
Current Consumption:	On	14mA @ 24 VDC
	Off	7mA @ 24 VDC
Switching Current	100mA @ 24 VDC, 30mA @ 5 VDC	
Voltage Drop	1.5 V max @ 100mA	
Response Frequency	1 KHz max	
LED Indicators:	Power On	Green
	Switch Active	Red
Operating Temperature	-10°C to 70°C (14°F to 158°F)	
Circuit Protection	Reverse Polarity, Surge Suppression	
Enclosure Classification	IEC 529 IP67, NEMA 6P	
Cable	3.3 dia, 3C, 24 AWG, Black PVC	
Housing	Zinc Diecast - Black	Zinc Diecast - Silver
Shock	50 G max	
Vibration	9 G max	

Flying Lead Sensors - Part #: NPL, PNL

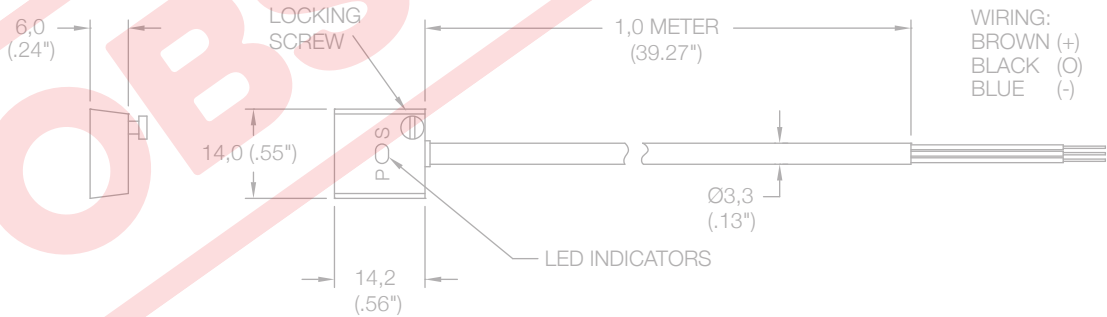

Quick Disconnect Sensors - Part #: NPP, PNP

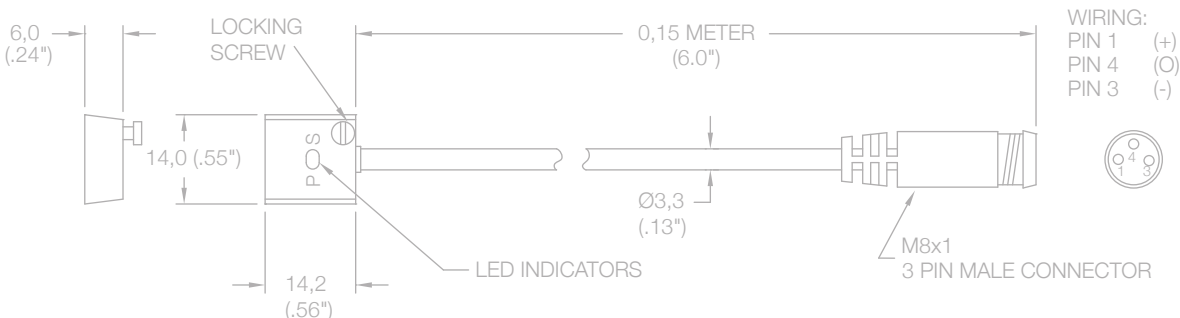

Mates with Part Number "SR" sensor receptacle. See page 90.

Sensor Receptacle

8mm female molded locking connector
 Mates with SCP, SKP, NPP, PNP Sensors

Part #: SR

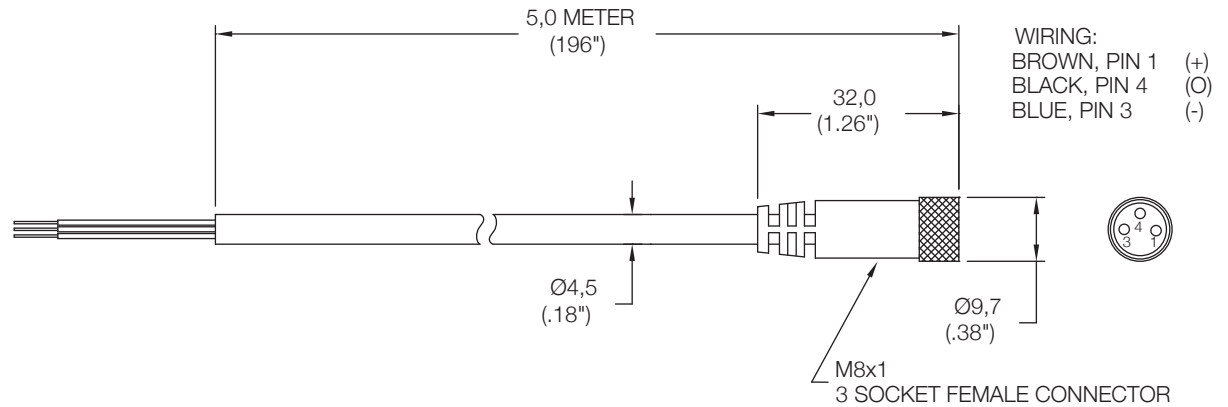

Sensor Schematics

PNP (Sourcing) output sensors complete a circuit by connecting the load to the supply current. These sensors are typically used on controllers with a single power supply. All sensors will utilize the same supply voltage.

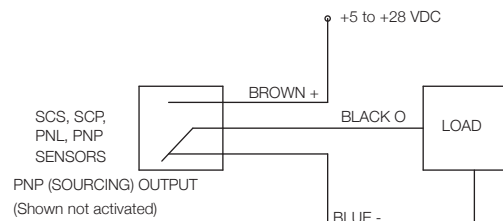

NPN (Sinking) output sensors complete a circuit by connecting the load to ground. These sensors are typically used on controllers with multiple power supplies. All sensors can utilize different supply voltages. The ground is their common factor.

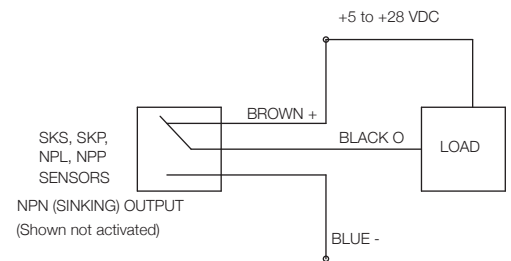

Important Notes

- All Nason sensors are magnetically activated devices. Cylinders should be ordered with option "M" for a magnetic piston.
- Presence of electromagnetic fields, external magnets, welding fields, etc. may effect operation of Nason sensors.
- Temperature ratings for sensors should be observed and will override seal option temperature ratings of the cylinder.

Features

- Hardened Steel Components with Black Oxide Finish
- 0,15mm (.006") Max. Axial Play
- Temperature rating -10°C to 204°C (0°F to 400°F)

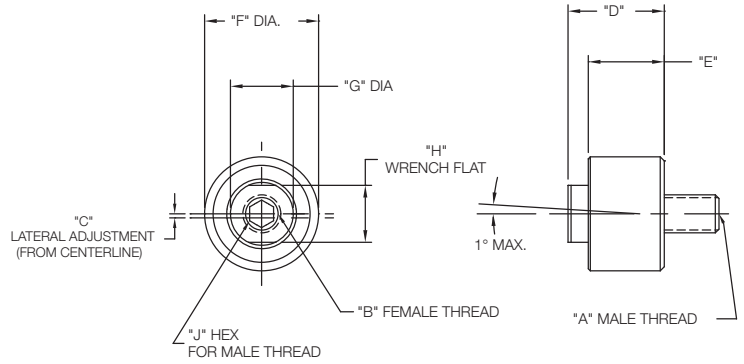

Bore Part Number	A Male Thread	B Female Thread	C	D	E	F	G	H	J	Load Rating
										Max Pull 5 X S.F.
AC-M4	M4x0,7 X 6,3mm	M4x0,7 X 5,5mm	0,5 (.02")	10,3 (.40")	8,7 (.34")	14,0 (.55")	6,0 (.24")	5,0 (.20")	2,5	.67 kN (150 lbs.)
AC-M4-C8	M4x0,7 X 6,3mm	#8-32 X .22"								
AC-C8	#8-32 X .31"	#8-32 X .22"								
AC-C8-M4	#8-32 X .31"	M4x0,7 X 5,5mm	0,8 (.03")	14,3 (.56")	10,3 (.41")	19,0 (.75")	8,0 (.31")	7,0 (.28")	5/64	1.11 kN (250 lbs.)
AC-M5	M5x0,8 X 8,4mm	M5x0,8 X 8,0mm								
AC-M5-F10	M5x0,8 X 8,4mm	#10-32 X .31"								
AC-M5-C10	M5x0,8 X 8,4mm	#10-24 X .31"							3/32	
AC-F10	#10-32 X .31"	#10-32 X .31"								
AC-F10-M5	#10-32 X .31"	M5x0,8 X 8,0mm								
AC-F10-C10	#10-32 X .31"	#10-24 X .31"								
AC-C10	#10-24 X .31"	#10-24 X .31"								
AC-C10-M5	#10-24 X .31"	M5x0,8 X 8,0mm								
AC-C10-F10	#10-24 X .31"	#10-32 X .31"								
AC-M6	M6x1,0 X 9,5mm	M6x1,0 X 11,0mm	0,8 (.03")	19,3 (.76")	14,3 (.56")	28,5 (1.13")	12,7 (.50")	11,0 (.43")	4	3.55 kN (800 lbs.)
AC-M6-C14	M6x1,0 X 9,5mm	1/4-20 X .44"								
AC-M6-F14	M6x1,0 X 9,5mm	1/4-28 X .44"								
AC-C14	1/4-20 X .41"	1/4-20 X .44"							1/8	
AC-C14-M6	1/4-20 X .41"	M6x1,0 X 11,0mm								
AC-C14-F14	1/4-20 X .41"	1/4-28 X .44"								
AC-F14	1/4-28 X .41"	1/4-28 X .44"								
AC-F14-M6	1/4-28 X .41"	M6x1,0 X 11,0mm								
AC-F14-C14	1/4-28 X .41"	1/4-20 X .44"								
AC-M8	M8x1,25 X 13,7mm	M8x1,25 X 12,0mm								
AC-M8-C516	M8x1,25 X 13,7mm	5/16-18 X .50"								
AC-M8-F516	M8x1,25 X 13,7mm	5/16-24 X .50"								
AC-C516	5/16-18 X .54"	5/16-18 X .50"	5/32							
AC-C516-M8	5/16-18 X .54"	M8x1,25 X 12,0mm								
AC-C516-F516	5/16-18 X .54"	5/16-24 X .50"								
AC-F516	5/16-24 X .54"	5/16-24 X .50"								
AC-F516-M8	5/16-24 X .54"	M8x1,25 X 12,0mm								
AC-F516-C516	5/16-24 X .54"	5/16-18 X .50"								
AC-M10	M10x1,5 X 13,7mm	M10x1,5 X 14,0mm		0,8 (.03")	24,0 (.95")	19,0 (.75")	28,5 (1.13")	16,0 (.63")	14,0 (.55")	6
AC-M10-F38	M10x1,5 X 13,7mm	3/8-24 X .56"								
AC-M10-C38	M10x1,5 X 13,7mm	3/8-16 X .56"								
AC-F38	3/8-24 X .54"	3/8-24 X .56"	3/16							
AC-F38-M10	3/8-24 X .54"	M10x1,5 X 14,0mm								
AC-F38-C38	3/8-24 X .54"	3/8-16 X .56"								
AC-C38	3/8-16 X .54"	3/8-16 X .56"								
AC-C38-M10	3/8-16 X .54"	M10x1,5 X 14,0mm								
AC-C38-F38	3/8-16 X .54"	3/8-24 X .56"								
AC-M12	M12x1,75 X 21,8mm	M12x1,75 X 22,0mm								1,5 (.06")
AC-M12-C12	M12x1,75 X 21,8mm	1/2-13 X .88"								
AC-M12-F12	M12x1,75 X 21,8mm	1/2-20 X .88"								
AC-C12	1/2-13 X .88"	1/2-13 X .88"	1/4							
AC-C12-M12	1/2-13 X .88"	M12x1,75 X 22,0mm								
AC-C12-F12	1/2-13 X .88"	1/2-20 X .88"								
AC-F12	1/2-20 X .88"	1/2-20 X .88"								
AC-F12-M12	1/2-20 X .88"	M12x1,75 X 22,0mm								
AC-F12-C12	1/2-20 X .88"	1/2-13 X .88"								

Face Flange Mounting - "FF" & "FR"
12mm Thru 76mm Bores

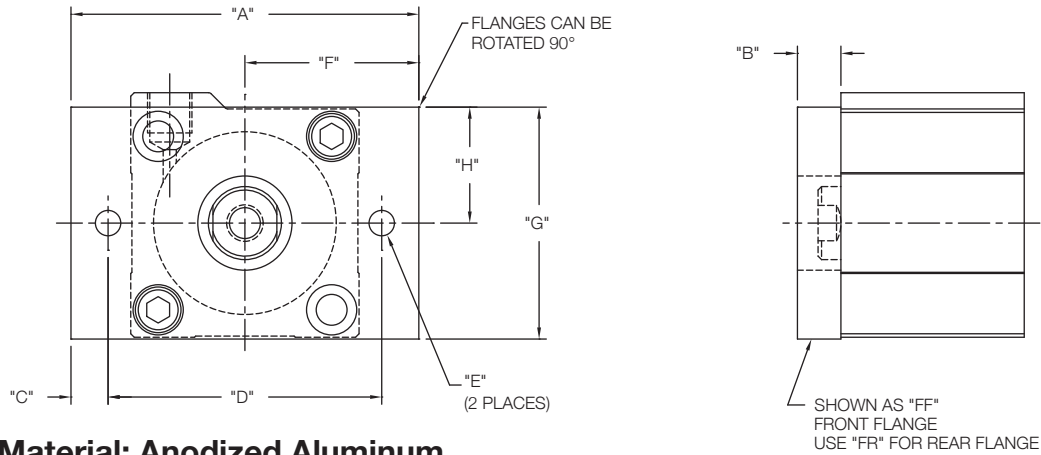

Material: Anodized Aluminum

Face Flange Mounting - "FF" & "FR"
101mm Thru 152mm Bores

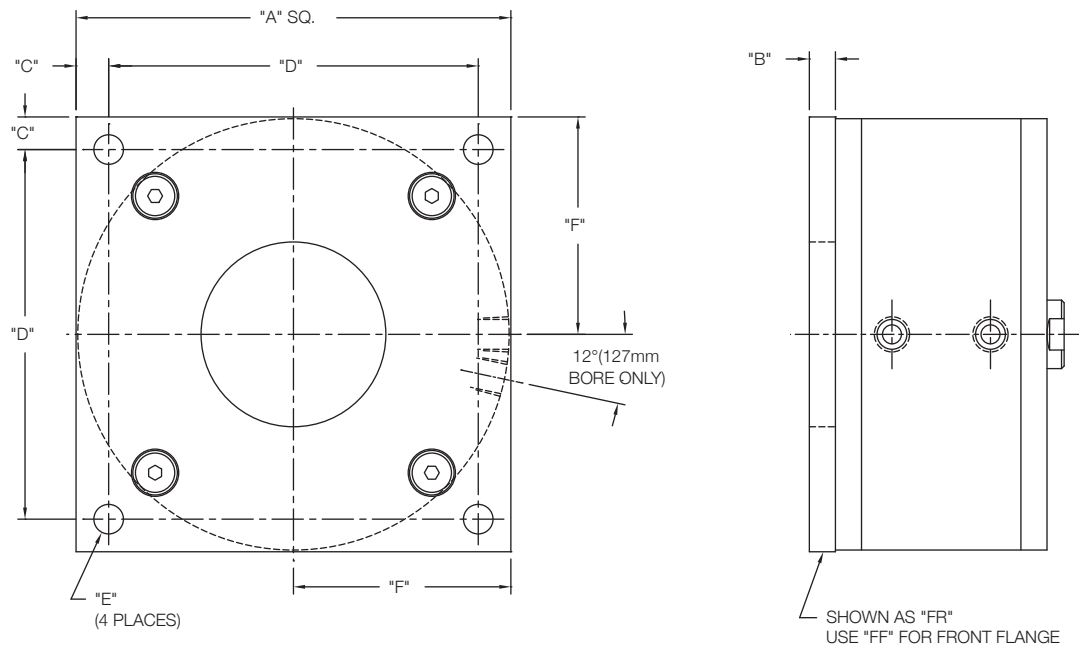

Material:
101mm Bore - Anodized Aluminum
127mm & 152mm Bore - Zinc Plated Steel

BORE	"A"	"B"	"C"	"D"	"E"	"F"	"G"	"H"
12	50,8 (2.0")	6,4 (.25")	5,4 (.21")	40,0 (1.58")	4,5 (.18")	25,4 (1.0")	22,2 (0.88")	11,1 (.44")
20		9,5 (.38")	3,9 (.15")	43,0 (1.69")			31,8 (1.25")	15,9 (.63")
25		6,4 (.25")	6,4 (.25")	50,8 (2.00")			38,1 (1.50")	19,05 (.75")
28,5	63,5 (2.5")	9,5 (.38")	5,75 (.23")	52,0 (2.05")	5,5 (.22")	31,8 (1.25")	44,5 (1.75")	22,25 (.88")
32	8,1 (.32")		60,0 (2.36")	38,1 (1.50")			50,8 (2.00")	25,4 (1.00")
40	76,2 (3.0")	12,7 (.50")	7,5 (.30")	78,0 (3.07")	8,5 (.33")	46,5 (1.83")	63,5 (2.50")	31,8 (1.25")
50	93,0 (3.66")	19,05 (.75")	9,0 (.35")	102,0 (4.02")	10,5 (.41")	59,9 (2.36")	76,2 (3.00")	38,1 (1.50")
63	120,0 (4.72")		115,1 (4.53")	66,5 (2.62")			88,9 (3.50")	44,45 (1.75")
76	133,1 (5.24")		108,0 (4.25")	8,64 (.34")			63,5 (2.50")	N/A
101	127,0 (5.0")	9,5 (.38")	12,7 (.50")	152,4 (6.00")	10,5 (.41")	88,9 (3.50")	N/A	N/A
127	177,8 (7.0")	9,5 (.38")	12,7 (.50")	152,4 (6.00")	10,5 (.41")	88,9 (3.50")	N/A	N/A
152								

Side Flange Mounting - "FS"
12mm Thru 76mm Bores

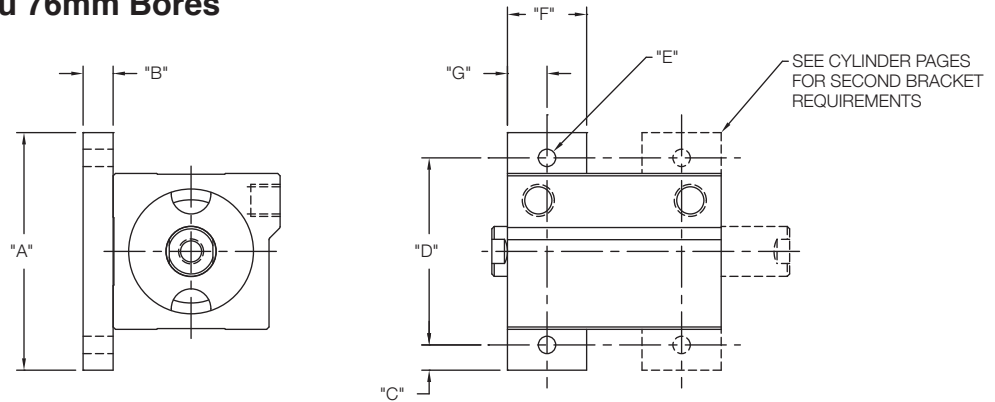

Material: Anodized Aluminum

Bore	"A"	"B"	"C"	"D"	"E"	"F"	"G"
12	44,5 (1.75")	6,35 (.25")	4,8 (.19")	35 (1.38")	4,5 (.18")	16 (.63")	7,9 (.31")
20	50,8 (2.0")	9,5 (.38")	5,4 (.21")	40 (1.58")		19 (.75")	9,5 (.38")
25			3,9 (.15")	43 (1.69")			
28,5	63,5 (2.5")	4,8 (.19")	6,35 (.25")	50,8 (2.0")	5,5 (.22")	25,4 (1.00")	12,7 (.50")
32			9,5 (.38")	5,75 (.23")	52 (2.05")		
40	8,1 (.32")	60 (2.36")					
50	93 (3.66")	12,7 (.50")	7,5 (.30")	78 (3.07")	8,5 (.33")		
63	120 (4.72")	19 (.75")	9,0 (.35")	102 (4.02")	10,5 (.41")		
76	133 (5.24")			115 (4.53")			

End Flange Mounting - "FE"
12mm Thru 76mm Bores

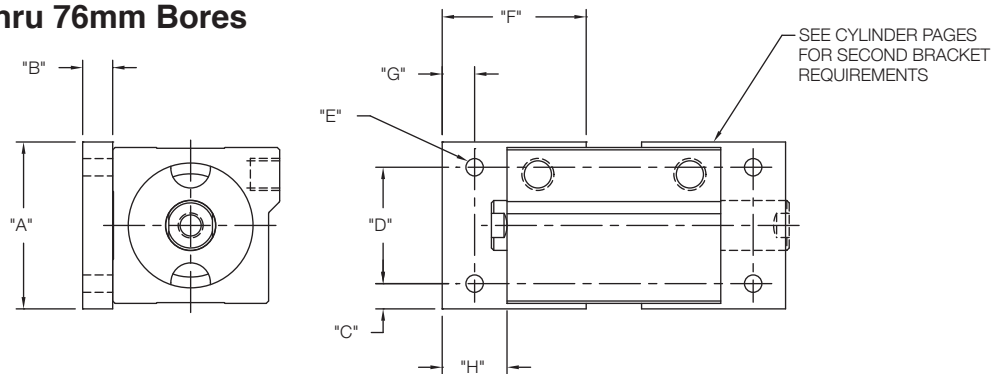

Material: Anodized Aluminum

Bore	"A"	"B"	"C"	"D"	"E"	"F"	"G"	"H"
12	25,4 (1.00")	6,35 (.25")	4,2 (.17")	17,0 (.67")	4,5 (.18")	24,0 (.95")	4,0 (.16")	8,0 (.32")
20	31,8 (1.25")	9,5 (.38")	4,4 (.17")	23,0 (.91")		27,0 (1.06")		
25	38,1 (1.50")		4,05 (.16")	30,0 (1.18")				
28,5	38,1 (1.50")	4,8 (.19")	4,8 (.19")	28,6 (1.13")	5,6 (.22")	28,6 (1.13")	4,8 (.19")	9,7 (.38")
32	44,5 (1.75")	9,5 (.38")	5,0 (.20")	34,5 (1.36")	5,5 (.22")	35,4 (1.39")	5,0 (.20")	10,0 (.39")
40	50,8 (2.00")		4,9 (.19")	41,0 (1.61")				
50	63,5 (2.50")	12,7 (.50")	8,0 (.32")	47,5 (1.87")	8,5 (.33")	41,4 (1.63")	8,0 (.32")	16,0 (.63")
63	76,2 (3.00")	19 (.75")	10,1 (.40")	56,0 (2.20")	10,5 (.41")	45,4 (1.79")	10,0 (.39")	20,0 (.79")
76	88,9 (3.50")		9,95 (.39")	69,0 (2.72")				

Long Pivot Mounting Style - "PL"

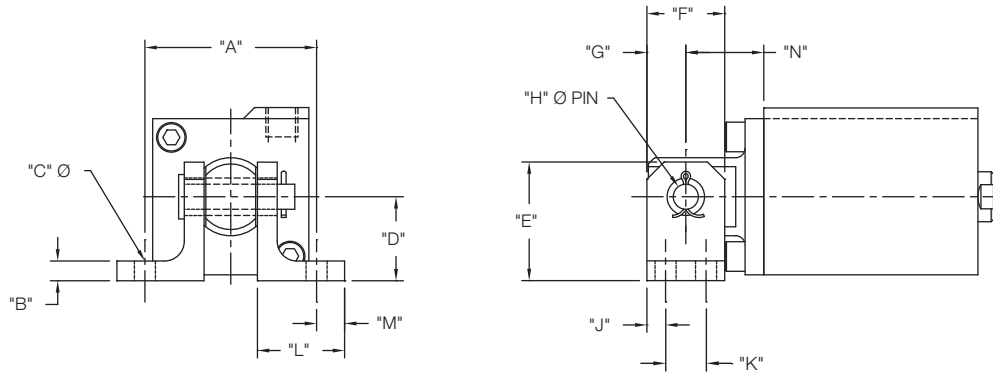

Bore	"A"	"B"	"C"	"D"	"E"	"F"	"G"	"H"	"J"	"K"	"L"	"M"	"N"			
20	48,8 (1.92")	6,35 (.25")	5,4 (.21")	20 (.79")	31,8 (1.25")	25 (.98")	12,5 (.49")	8,0 (.32")	6,0 (.24")	13 (.51")	25,0 (.98")	7,0 (.28")	23,0 (.91")			
25	52,8 (2.08")															
28.5	48,3 (1.90")															
32	54,9 (2.16")	9,53 (.38")	6,8 (.27")	22 (.87")	31,8 (1.25")	25 (.98")	12,5 (.49")	8,0 (.32")	6,0 (.24")	13 (.51")	28,0 (1.10")	9,0 (.35")	25,0 (.98")			
40	58,7 (2.31")										27 (1.06")			38,1 (1.50")	30,0 (1.18")	
50	65,8 (2.59")		8,7 (.34")	46 (1.81")	63,5 (2.50")	40 (1.58")	20,0 (.79")	10,0 (.39")	10,0 (.39")	20 (.79")	40,0 (1.58")	36,0 (1.42")	13,0 (.51")	16,0 (.63")		
63	67,8 (2.67")	50,8 (2.00")										35 (1.38")			17,5 (.69")	36,0 (1.42")
76	73,7 (2.90")	50,8 (2.00")										35 (1.38")			17,5 (.69")	36,0 (1.42")

- LONG PIVOTS ALLOW FOR A MINIMUM 180° OF MOVEMENT
- LONG PIVOTS ARE ANODIZED ALUMINUM WITH SINTERED BRONZE BEARINGS
- PIVOT PINS ARE STEEL WITH STEEL COTTER PIN, INCLUDED

Pivot on Rear Face Mounting Style - "PR"

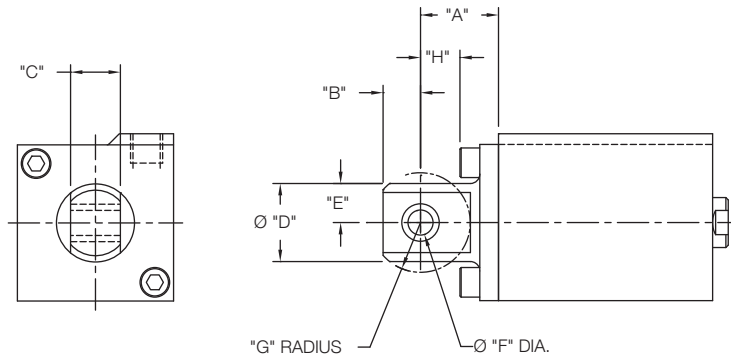

Bore	"A"	"B"	"C"	"D"	"E"	"F"	"G"	"H"
12	20 (.79")	5,9 (.23")	6 (.24")	12 (.47")	6 (.24")	5 (.20")	13,9 (.55")	10,9 (.43")
20	23 (.91")	12 (.47")	22 (.87")	11 (.43")	8 (.32")	14 (.55")	12,5 (.49")	
25								15,5 (.61")
28.5	25 (.98")	16 (.63")	25 (.98")	12,5 (.49")	7,9 (.31")	16 (.63")	12 (.47")	
32								
40								
50	40 (1.58")	14 (.55")	19 (.75")	35 (1.38")	17,5 (.69")	10 (.39")	25 (.98")	23 (.91")
63								21 (.83")
76								25 (.98")

- REAR PIVOT CAN BE ROTATED 90°
- REAR PIVOT OPTION IS ONLY AVAILABLE ON SINGLE END MODELS ONLY
- REAR PIVOTS ARE ANODIZED ALUMINUM WITH A SINTERED BRONZE BEARING

Hollow Rod

Hollow Rod - Options "HR" and "HP"
 Thru hole for type "D" in Models "LS" and "LH"

"HR" - Hollow rod with standard taps
 "HP" - Hollow rod with taps for fittings

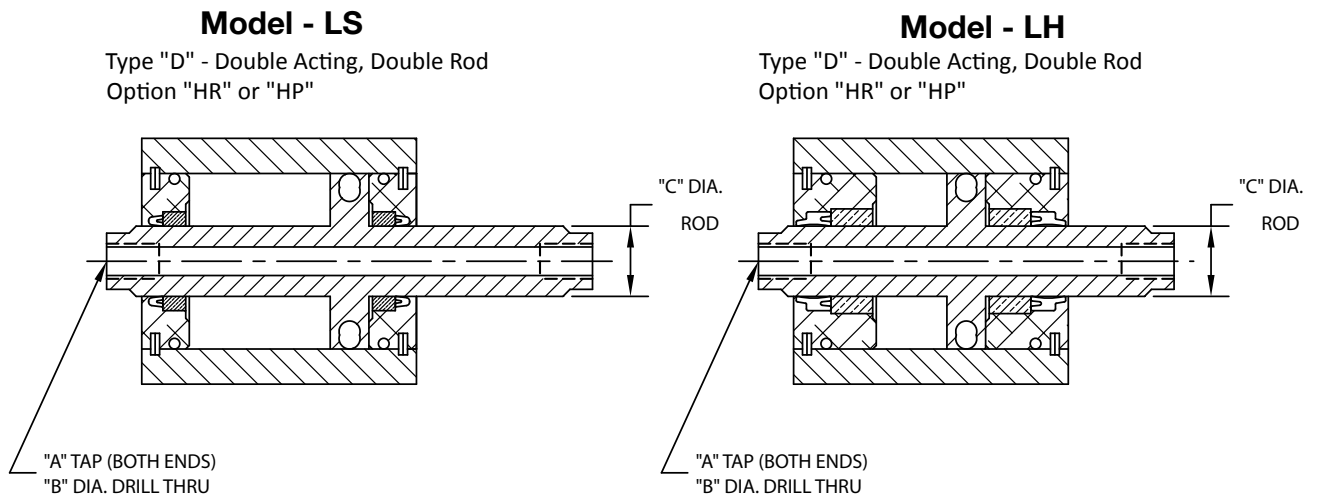

Bore	"C" Dia. Rod	HR Standard		HR "EM" Option		HP Standard		HP "EM" Option	
		"A" Tap	"B" Dia Thru	"A" Tap	"B" Dia Thru	"A" Tap	"B" Dia Thru	"A" Tap	"B" Dia Thru
20	8,0 (.315")	NA	NA	NA	NA	M5x0,8	1,2mm(.05")	#10-32	1,2mm(.05")
25	10,0 (.394")	NA	NA	NA	NA	M5x0,8	1,2mm(.06")	#10-32	1,2mm(.06")
28.5	12,0(.472")	5/16-18	6,9mm(.26")	NA	NA	M5x0,8	1,2mm(.16")	#10-32	1,2mm(.16")
32	12,0(.472")	M6X1,0	5,1mm(.20")	1/4-20	5,1mm(.20")	M5x0,8	1,2mm(.16")	#10-32	1,2mm(.16")
40	16,0(.630")	M8X1,25	6,6mm(.26")	5/16-18	6,6mm(.26")	G1/8	8,7mm(.34")	1/8-27 NPTF	8,7mm(.34")
50	16,0(.630")	M10X1,5	8,5mm(.33")	3/8-24	8,5mm(.33")	G1/8	8,7mm(.34")	1/8-27 NPTF	8,7mm(.34")
63	20,0(.787")	M12X1,75	10,2mm (.40")	1/2-13	10,5mm(.42")	G1/4	11,0mm(.43")	1/4-18 NPTF	11,4mm(.45")
76	20,0(.787")	M12X1,75	10,2mm (.40")	1/2-13	10,5mm(.42")	G1/4	11,0mm(.43")	1/4-18 NPTF	11,4mm(.45")
101	20,0(.787")	M12X1,75	10,2mm (.40")	1/2-13	10,5mm(.42")	G1/4	11,0mm(.43")	1/4-18 NPTF	11,4mm(.45")
127	20,0(.787")	M12X1,75	10,2mm (.40")	1/2-13	10,5mm(.42")	G1/4	11,0mm(.43")	1/4-18 NPTF	11,4mm(.45")
152	25,0(.984")	M16X2,0	14,0mm(.55")	5/8-18	14,5mm (.57")	G1/4	11,0mm(.43")	1/4-18 NPTF	11,4mm(.45")

Notes:

1. Maximum Operating Pressure of Cylinder with "HR" or "HP" option is 150 PSI Pneumatic Service Only. Not available with "SH" (Hydraulic Seals) Option.
2. Pressure Rating for ID of hollow rod is 28inHg (Vacuum) to 150 PSI.
3. For oversized rod diameters, undersize rod diameters, large thru holes, and custom threads contact Nason for a Custom Part Number

**Rod Eye
Option - "RE"**

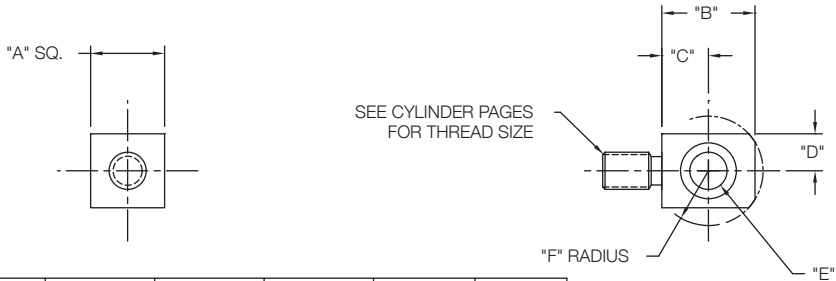

Bore	"A"	"B"	"C"	"D"	"E"	"F"
12	7,9(.31")	8,0(.32")	4,0(.16")	3,96(.156")	3,0(.119")	5,0(.20")
20	12,7 (.50")	12 (.47")	6 (.24")	6,35 (.25")	5 (.20")	8 (.32")
25		12,7(.50")	6,35(.25")		6,35(.25")	7,6(.30")
28,5	16 (.63")	20 (.79")	10 (.39")	8 (.32")	8 (.32")	12 (.47")
32		20 (.79")	10 (.39")	8 (.32")	8 (.32")	12 (.47")
40	19 (.75")	25 (.98")	12,5 (.49")	9,5 (.38")	10 (.39")	14 (.55")
50				12,7 (.50")		
63	25,4 (1.00")			12,7 (.50")		
76						

**Rod Extensions
Option - See Chart Below**

Extension	"RF"	"RT"	"RN"	"RY"	"RV"	"RH"
Length	5 (.20")	10 (.39")	15 (.59")	20 (.79")	25 (.98")	35 (1.38")

For standard extension, see catalog pages.
If cylinder is double ended, extension will be on both ends.
Consult factory for single ended extension on a double ended cylinder.

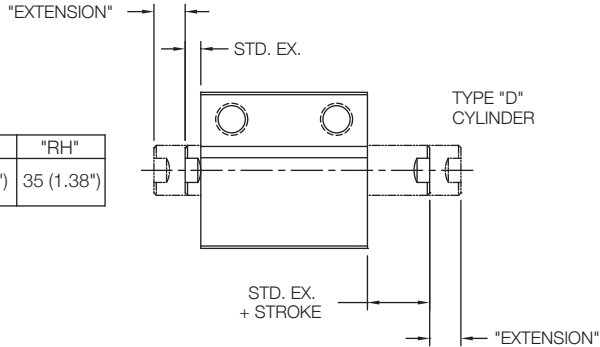

**Rod Stud
Option - "RS"**

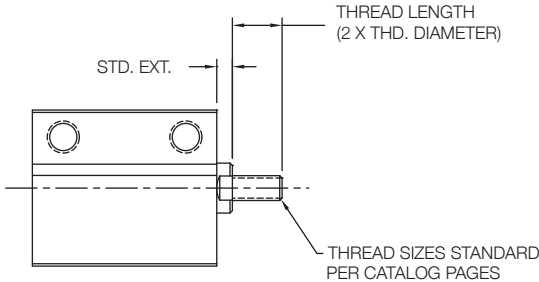

Bore	Std. Ext.	Thread Length
12	3 (.12")	8 (.32")
20	3 (.12")	10 (.39")
25	5 (.20")	10 (.39")
28,5	3,2(.13")	16(.63")
32	5 (.20")	12 (.47")
40	5 (.20")	16 (.63")
50	5 (.20")	20 (.79")
63	5 (.20")	24 (.95")
76	5 (.20")	24 (.95")

**Urethane Shock Pads
Option - "UF", "UR", "UB"**

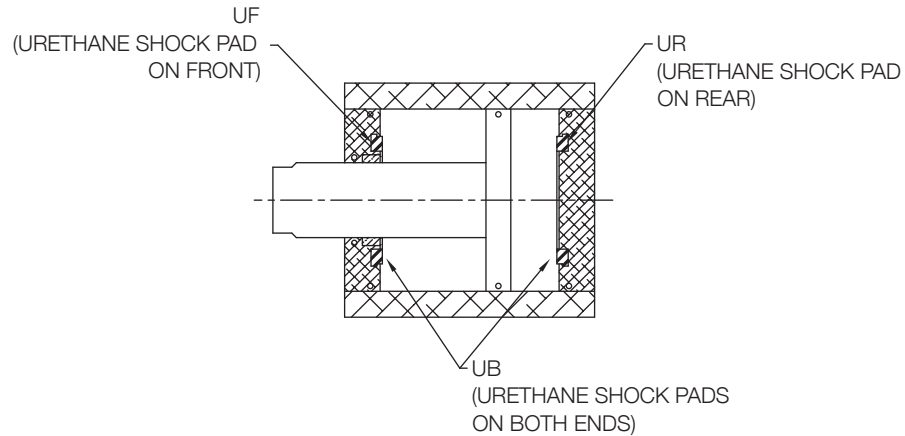

- Urethane shock pads available on 20mm thru 76mm Bores in models LS, LE, LH, and LC.
- Pneumatic service only.
- Temperature rating: -18°C to 82°C (0°F -180°F).
- Use for increased noise reduction, minor piston impact, or high cycle rates.
- Does not increase cylinder length.
- Shock pads mechanically retained in cap and head.
- Shock pads are replaceable.
- Shock pads are NOT suitable replacements in applications requiring shock absorbers.

Seal Options

OPTION	MATERIAL	MODEL	BORE SIZE	PRESSURE RATING	TEMPERATURE RATING	MEDIA
BLANK (NO CODE)	NITRILE	LS, LE, LH	12mm 20mm thru 76mm 101mm thru 152mm	10 BAR (150 PSI) 17 BAR (250 PSI) 14 BAR (200 PSI)	-18°C to 95°C (0°F to 200°F)	Air (Clean, Dry or Lubricated)
HS	FLUOROCARBON	LE, LH	12mm 20mm thru 76mm 101mm thru 152mm	10 BAR (150 PSI) 17 BAR (250 PSI) 14 BAR (200 PSI)	-18°C to 150°C (0°F to 302°F)	Air (Clean, Dry or Lubricated)
SH	NITRILE	LS, LE, LH	20mm thru 76mm	35 BAR (500 PSI)	-10°C to 70°C (14°F to 158°F)	Hydraulic Fluid (Mineral Oil, Water Polyglycol Solutions Water-in-Oil Emulsions)

- Temperature and pressure ratings are based on a combination of seal materials, lubrication, and cylinder design.
- For higher or lower temperature and/or pressure ratings, consult Nason for a custom solution. Nason has successfully designed cylinders to operate at temperature extremes of -40°F and +500°F respectively, as well pressures as low as 5PSI and as high as 3000 PSI.

LC SERIES

NON-ROTATING LOAD CARRYING CYLINDERS

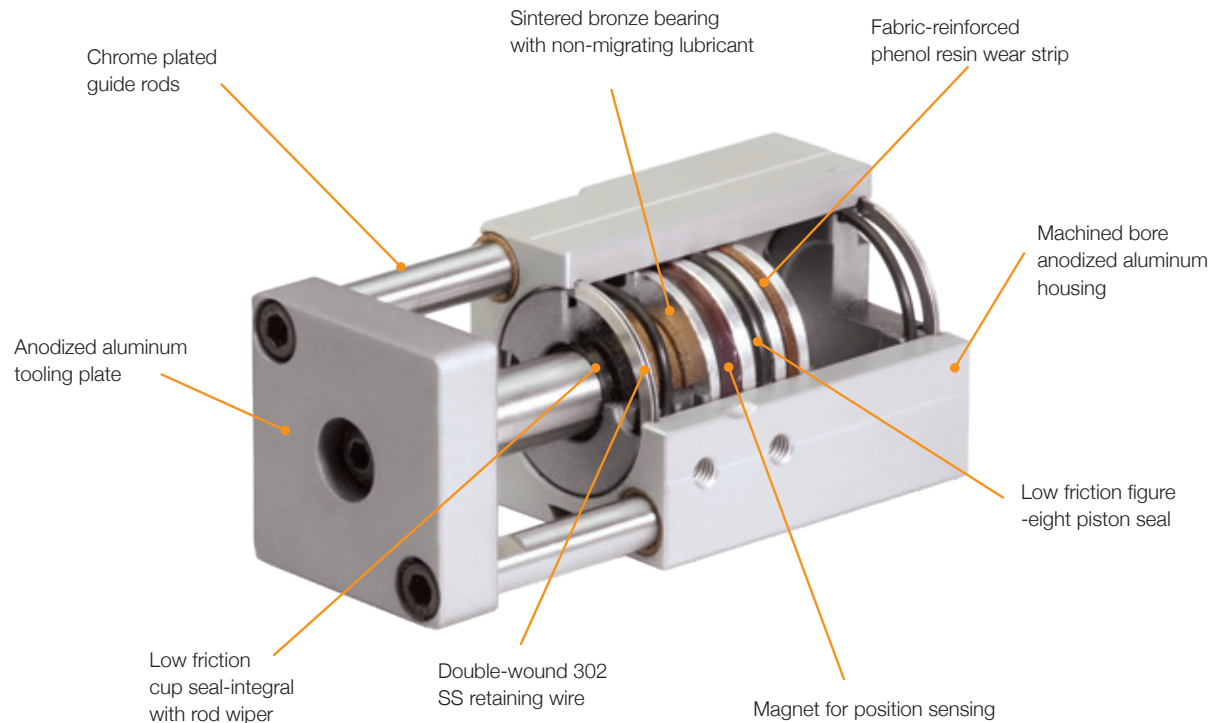

Common Features

Nason's LC series of pneumatic guided load actuators were designed to be compact, long-lasting, load carrying devices for today's demanding design requirements. They are offered in various mounting styles, bores, and strokes to fulfill the needs of today's design engineers.

Actuator

The LC series guided cylinder actuator is based on Nason's LH cylinder. The extended internal rod bearing, wear banded piston, and integral rod wiper are all standard. Precision-machined components, self-lubricating bearings, and PTFE impregnated lubricant ensure long life and continued low friction operation.

Guiding Mechanism

Oversized, chrome-plated guide rods riding in specially formulated sintered bronze bearings provide rigid load-carrying capability. Guide

rods are located outside the sealed cylinder chamber but inside the overall envelope of the cylinder. The guide rods extend past the cylinder housing to ensure no finger trap exists. The guide rods are piloted into the tooling plate to provide more rigidity and ease of disassembly for modification.

Tooling Plate

Tooling plates are thick, anodized aluminum and are provided with tapped through holes for direct mounting, or through mounting, into your part.

Magnetic Piston Sensing

Magnetic piston and sensor mounting tracks are included as standard. See the sensor section for Nason's solid state sensor selection (sold separately).

Rebuildable

All LC series cylinders are field-rebuildable.

How to Order

Example:

Part Number: LC-20X40MR-EMHS

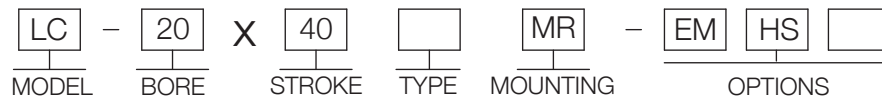

MODEL
LC - Non-Rotating, Guided Load cylinder

BORE
12 - 12mm (.47")
20 - 20mm (.79")
25 - 25mm (.98")
28.5 - 28.5mm (1.13")
32 - 32mm (1.26")
40 - 40mm (1.58")
50 - 50mm (1.97")
63 - 63mm (2.48")

STROKE
See Stroke Table

TYPE
Blank (No Code) - Double Acting, Single Rod
D - Double Acting, Double Rod

MOUNTING
MR - Threads on Rear Face (Opposite Rod)
MS - Threads on Side of Cylinder Body
FR - Flange on Rear Face (Opposite Rod)
PR - Pivot on Rear Face

OPTIONS
EM - InchThreads (Mounting, Ports, and Tooling Plate) (See product pages for sizes)
HS - High Temperature Seals -10°C to 150°C (0°F to 302°F) (Available on "LE" and "LH" Models Only)
BP - Blank Tooling Plate (No Holes)
PE - 1/4 Ports (Available on 50 and 63mm Bores) With EM Option
UB - Urethane Shock Pads Both Ends (20 thru 63mm Bores)
UF - Urethane Shock Pad Front (Rod End) (20 thru 63mm Bores)
UR - Urethane Shock Pad Rear (Opposite Rod) (20 thru 63mm Bores)

Operating Media: Air (Clean, Dry or Lubricated)
 Maximum Operating Pressure: 17 Bar (250 PSI)
 Operating Temperature: -10°C to 95°C (0°F to 200°F)
 Packing: Buna N
 Lubrication: PTFE impregnated grease
 Stroke Tolerance: +0,75mm/-0mm (+0.03"/-0")

Load Chart

1. Loads based on .08mm (.003") deflection up to 25mm stroke and .16mm (.006") deflection over 25mm stroke and maximum life.
2. Rotational tolerance = +/- .5 degree
3. Speed controls or external shock absorbers are recommended to reduce impact and extend cylinder life.

Piston Area Chart

Bore	Push (Rod Extend)	Pull (Rod Retract)
12	1,13 cm ² (.18 in ²)	0,85 cm ² (.14 in ²)
20	3,14 cm ² (.48 in ²)	2,64 cm ² (.40 in ²)
25	4,91 cm ² (.76 in ²)	4,12 cm ² (.64 in ²)
28.5	6,41 cm ² (1.0 in ²)	5,28 cm ² (.82 in ²)
32	8,04 cm ² (1.25 in ²)	6,91 cm ² (1.07 in ²)
40	12,56 cm ² (1.95 in ²)	10,55 cm ² (1.64 in ²)
50	19,63 cm ² (3.04 in ²)	17,62 cm ² (2.73 in ²)
63	31,17 cm ² (4.83 in ²)	28,03 cm ² (4.34 in ²)

Stock Stroke Table

Bore	Standard Stroke Lengths
12	15, 25, 40
20	15, 25, 40, 50
25	
28.5	12.7, 25.4, 38.1, 50.8
32	15, 25, 40, 50
40	
50	15, 25, 40, 50, 75
63	

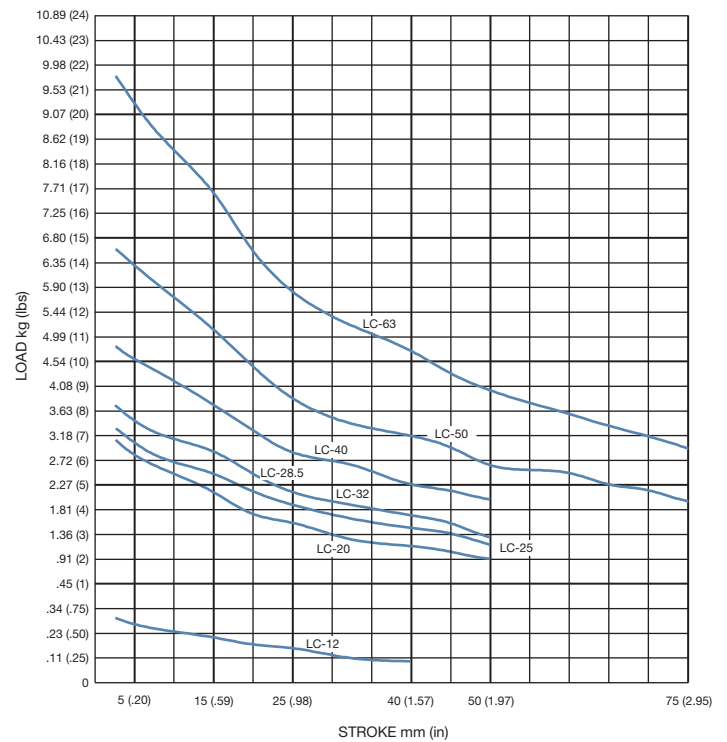

Cylinder Output Force Formula

Piston Area x Pressure = Output Force
Piston Area (in ²) x Pressure (PSI) = lbf (Pounds Force)
Piston Area (cm ²) x Pressure (kg/cm ²) = kgf (Kilograms Force)
Piston Area (cm ²) x Pressure (kg/cm ²) x 9.8 = Newtons
Piston Area (cm ²) x Pressure (Bar) x 10 = Newtons
Piston Area (cm ²) x Pressure (Bar) x 1.02 = kgf (Kilograms Force)

Rear Mount Cylinder "MR"

MODEL	STANDARD STROKES	"A"	PISTON AREA
LC	15mm	36,0(1.42")	PUSH 1,13 cm ² (0.18 in ²) PULL 0,85 cm ² (0.14 in ²)
	25mm		
	40mm		

	Standard Threads	"EM" Option
"B"	M4X0,7	#8-32
"C"	M5X0,8	#10-32
"D"	M4X0,7	#8-32

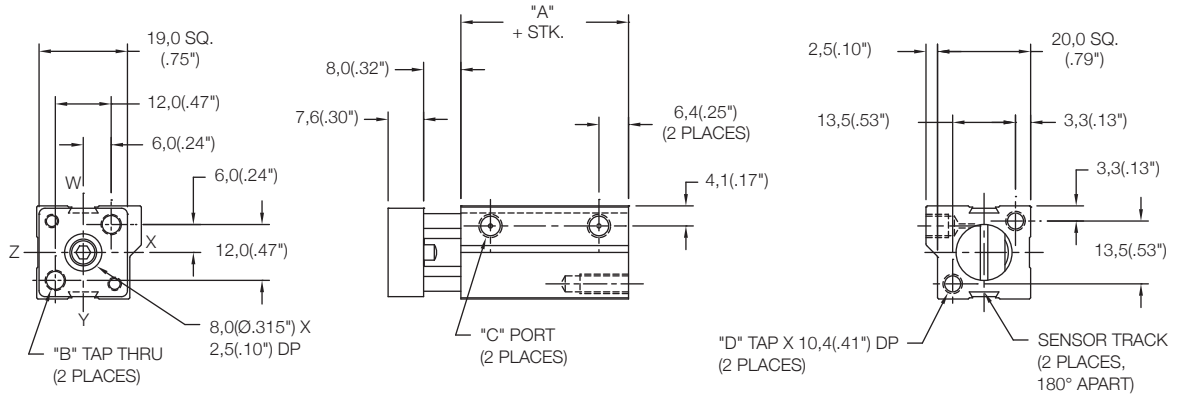

Side Mount Cylinder "MS"

MODEL	STANDARD STROKES	"A"	PISTON AREA
LC	15mm	36,0(1.42")	PUSH 1,13 cm ² (0.18 in ²) PULL 0,85 cm ² (0.14 in ²)
	25mm		
	40mm		

	Standard Threads	"EM" Option
"B"	M4X0,7	#8-32
"C"	M5X0,8	#10-32
"D"	M3X0,5	#4-40

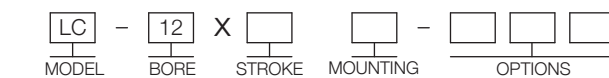
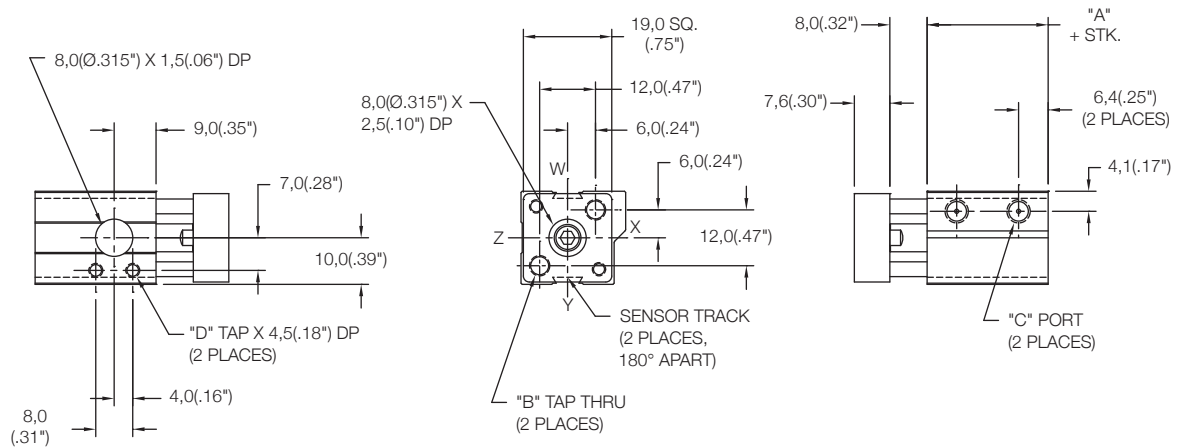

15mm - 40mm STROKE
(SEE CHART ABOVE)

MR - REAR MOUNT
MS - SIDE MOUNT
FR - REAR FLANGE
PR - PIVOT REAR
(SEE PAGE 92-94 FOR DETAILS)

SENSORS SOLD SEPARATELY
SKS, SKP, SCS, SCP - SOLID STATE
LIMIT SENSORS
(SEE CATALOG PAGE 88 FOR DETAILS)

EM - INCH THREADS & PORT OPTIONS:
HS - HIGH TEMPERATURE SEALS OPTION:
(SEE CATALOG PAGE 97 FOR DETAILS)
BP - BLANK TOOLING PLATE

Rear Mount Cylinder "MR"

MODEL	TYPE	STANDARD STROKES	"A"	PISTON AREA
LC	_D	15mm	33,5(1.32")	PUSH 3,14 cm ² (0.48 in ²)
		25mm		
		40mm		PULL 2,64 cm ² (0.40 in ²)
		50mm		

	Standard Threads	"EM" Option
"B"	M4X0,7	#8-32
"C"	M5X0,8	#10-32
"D"	M5X0,8	#10-32

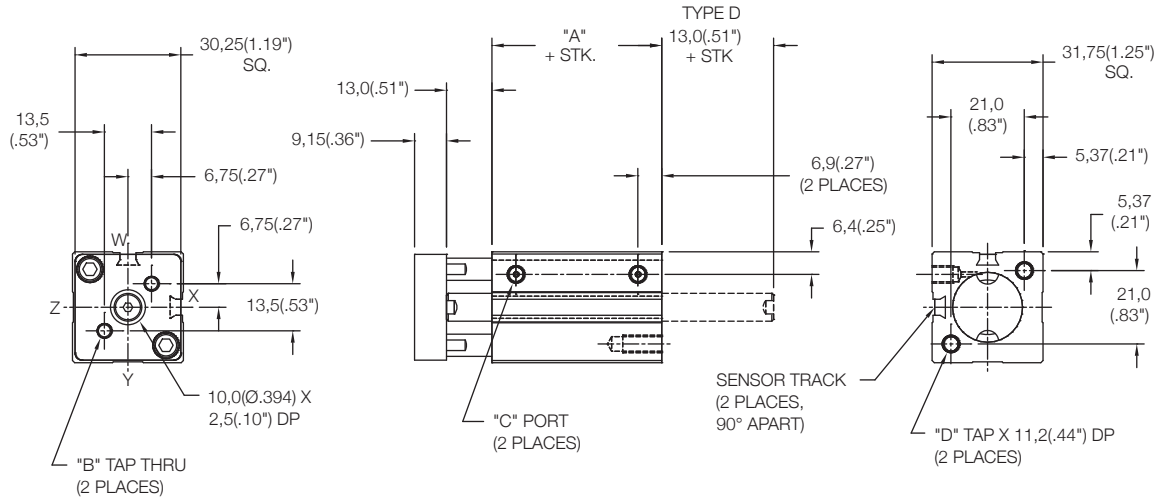

Side Mount Cylinder "MS"

MODEL	TYPE	STANDARD STROKES	"A"	PISTON AREA
LC	_D	15mm	33,5(1.32")	PUSH 3,14 cm ² (0.48 in ²)
		25mm		
		40mm		PULL 2,64 cm ² (0.40 in ²)
		50mm		

	Standard Threads	"EM" Option
"B"	M4X0,7	#8-32
"C"	M5X0,8	#10-32
"D"	M4X0,7	#8-32

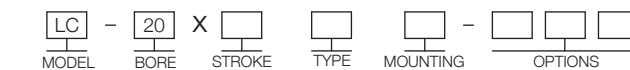
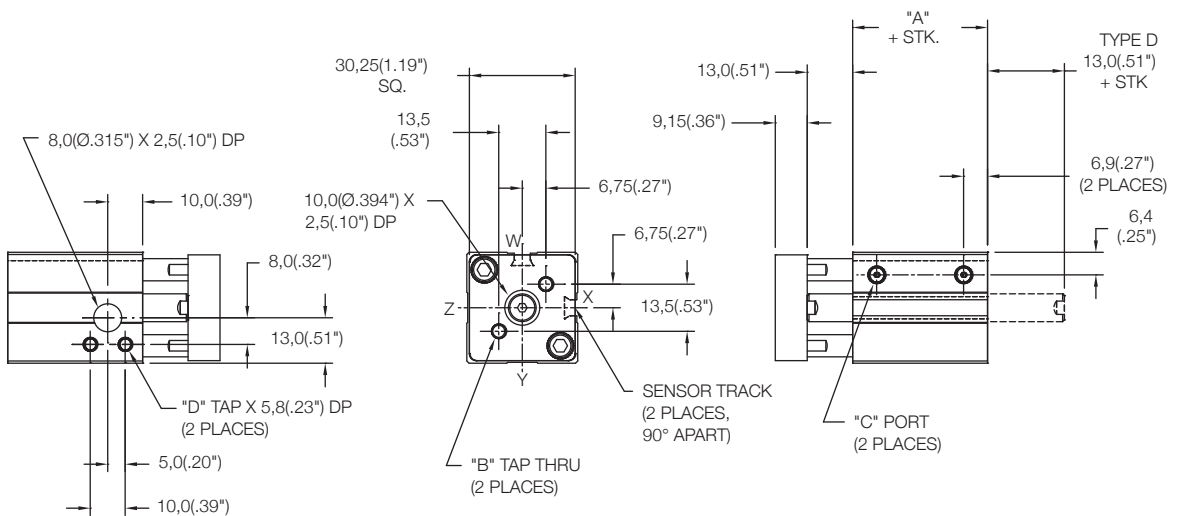

15mm - 50mm STROKE
(SEE CHART ABOVE)

BLANK - NO CODE
D - DOUBLE ROD
(SEE PAGE 99 FOR DETAILS)

MR - REAR MOUNT
MS - SIDE MOUNT
FR - REAR FLANGE
PR - PIVOT REAR
(SEE PAGE 92-94 FOR DETAILS)

SENSORS SOLD SEPARATELY
SKS, SKP, SCS, SCP - SOLID STATE
LIMIT SENSORS
(SEE CATALOG PAGE 88 FOR DETAILS)

EM - INCH THREADS & PORT OPTIONS:

HS - HIGH TEMPERATURE SEALS OPTION:
(SEE CATALOG PAGE 97 FOR DETAILS)

BP - BLANK TOOLING PLATE

UB, UF, UR - URETHANE SHOCK PAD OPTION
(SEE CATALOG PAGE 97 FOR DETAILS)

Rear Mount Cylinder "MR"

MODEL	TYPE	STANDARD STROKES	"A"	PISTON AREA
LC	_D	15mm	34,0(1.34")	PUSH 4,91 cm ² (0.76 in ²)
		25mm		
		40mm		PULL 4,12 cm ² (0.64 in ²)
		50mm		

	Standard Threads	"EM" Option
"B"	M5X0,8	#10-32
"C"	M5X0,8	#10-32
"D"	M5X0,8	#10-32
"E"	M6X1,0	1/4-20

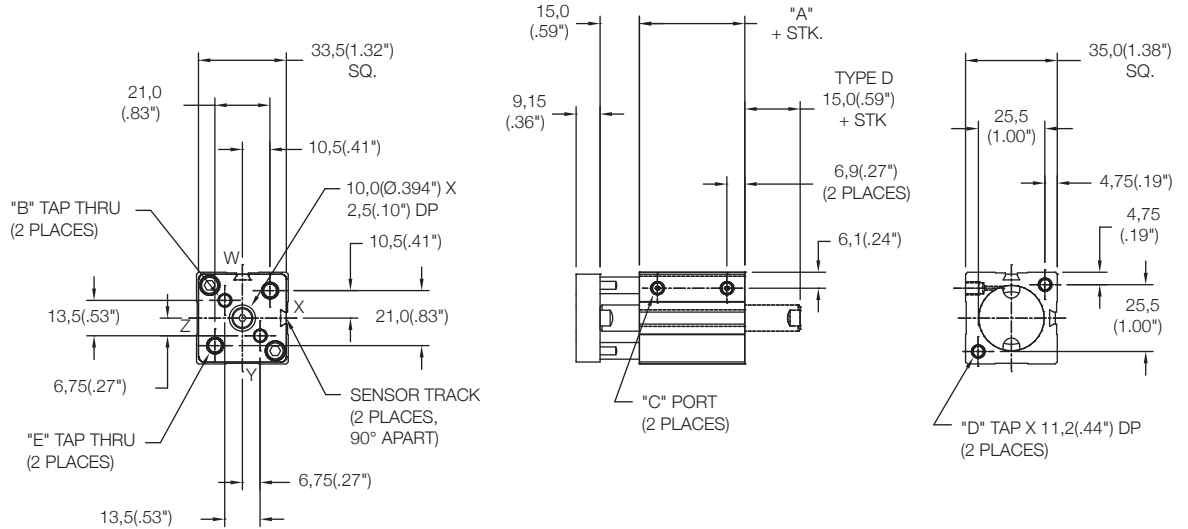

Side Mount Cylinder "MS"

MODEL	TYPE	STANDARD STROKES	"A"	PISTON AREA
LC	_D	15mm	34,0(1.34")	PUSH 4,91 cm ² (0.76 in ²)
		25mm		
		40mm		PULL 4,12 cm ² (0.64 in ²)
		50mm		

	Standard Threads	"EM" Option
"B"	M5X0,8	#10-32
"C"	M5X0,8	#10-32
"D"	M4X0,7	#8-32
"E"	M6X1,0	1/4-20

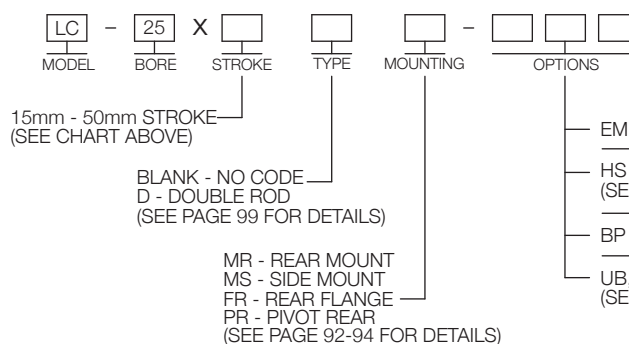
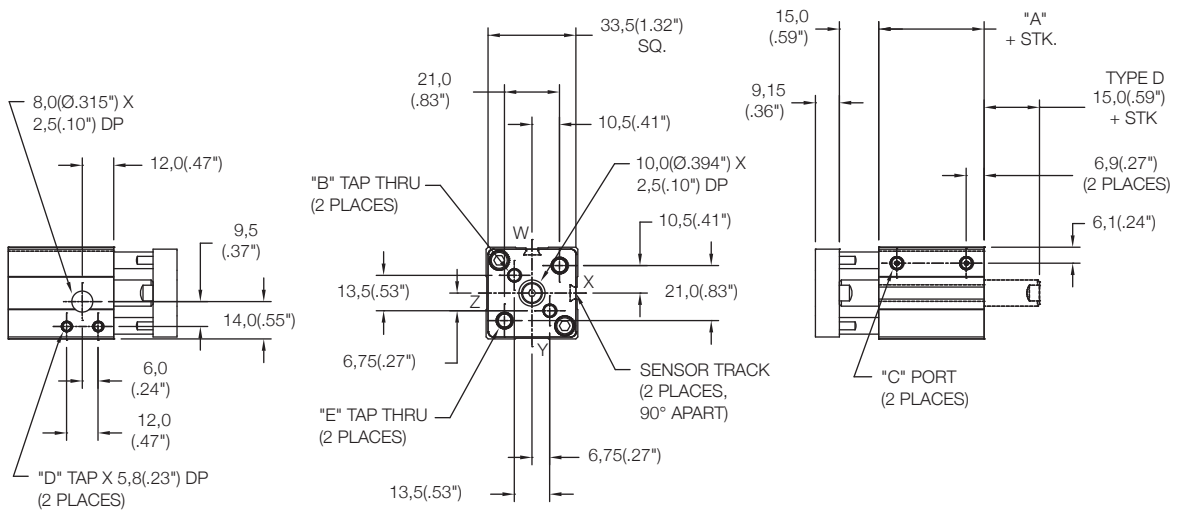

SENSORS SOLD SEPARATELY
SKS, SKP, SCS, SCP - SOLID STATE
LIMIT SENSORS
(SEE CATALOG PAGE 88 FOR DETAILS)

- EM - INCH THREADS & PORT OPTIONS:
- HS - HIGH TEMPERATURE SEALS OPTION:
(SEE CATALOG PAGE 97 FOR DETAILS)
- BP - BLANK TOOLING PLATE
- UB, UF, UR - URETHANE SHOCK PAD OPTION
(SEE CATALOG PAGE 97 FOR DETAILS)

Rear Mount Cylinder "MR"

MODEL	TYPE	STANDARD STROKES	"A"	PISTON AREA
LC	_D	12,7(.50")	38,1(1.50")	PUSH 6,41 cm ² (0.99 in ²)
		25,4(1.00")		
		38,1(1.50")		PULL 5,28 cm ² (0.82 in ²)
		50,8(2.00")		

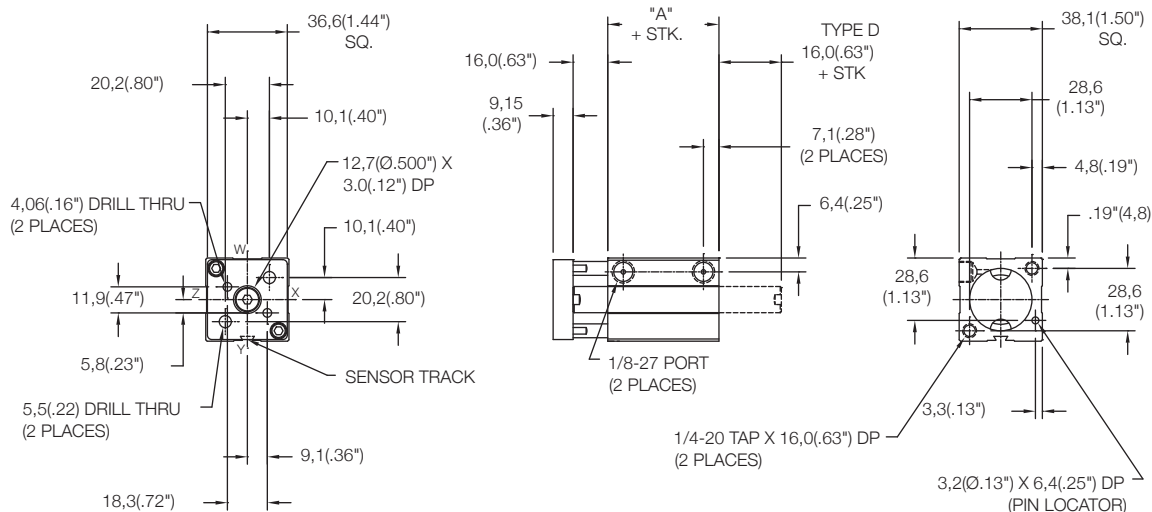

Side Mount Cylinder "MS"

MODEL	TYPE	STANDARD STROKES	"A"	PISTON AREA
LC	_D	12,7(.50")	38,1(1.50")	PUSH 6,41 cm ² (0.99 in ²)
		25,4(1.00")		
		38,1(1.50")		PULL 5,28 cm ² (0.82 in ²)
		50,8(2.00")		

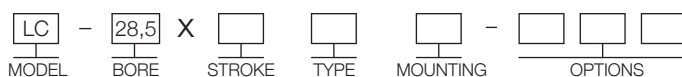
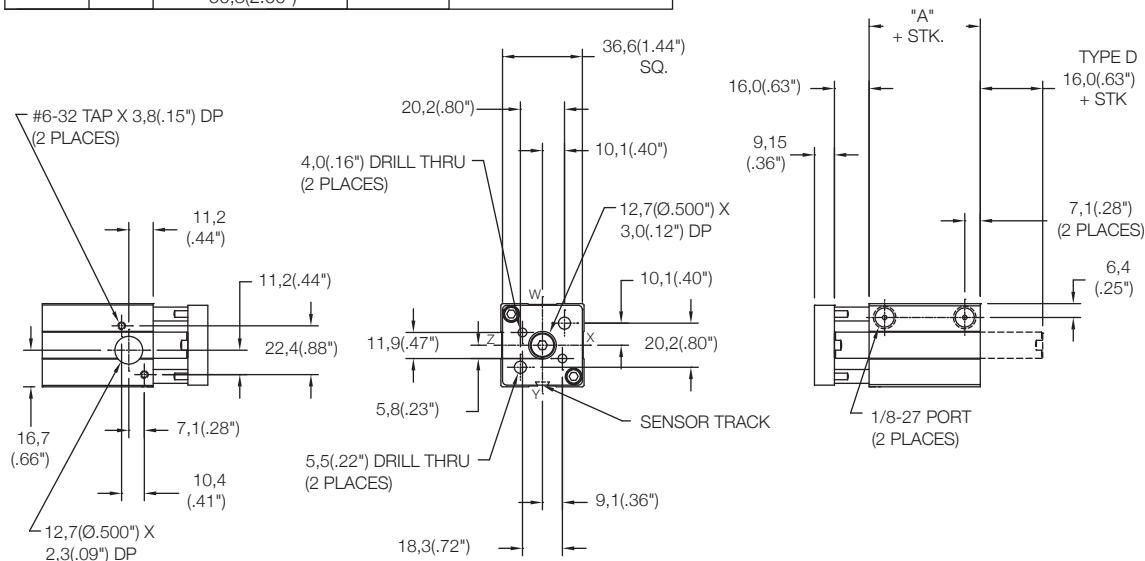

12,7(.50") - 50,8(2.00")
STROKE
(SEE CHART ABOVE)

BLANK - NO CODE
D - DOUBLE ROD
(SEE PAGE 99 FOR DETAILS)

MR - REAR MOUNT
MS - SIDE MOUNT
FR - REAR FLANGE
PR - PIVOT REAR
(SEE PAGE 92-94 FOR DETAILS)

SENSORS SOLD SEPARATELY
SKS, SKP, SCS, SCP - SOLID STATE
LIMIT SENSORS
(SEE CATALOG PAGE 88 FOR DETAILS)

HS - HIGH TEMPERATURE SEALS OPTION:
(SEE CATALOG PAGE 97 FOR DETAILS)

BP - BLANK TOOLING PLATE

UB, UF, UR - URETHANE SHOCK PAD OPTION
(SEE CATALOG PAGE 97 FOR DETAILS)

Rear Mount Cylinder "MR"

MODEL	TYPE	STANDARD STROKES	"A"	PISTON AREA
LC	_D	15mm	37,5(1.48")	PUSH 8,04 cm ² (1.25 in ²)
		25mm		
		40mm		PULL 6,91 cm ² (1.07 in ²)
		50mm		

	Standard Threads	"EM" Option
"B"	M5X0,8	#10-32
"C"	G1/8 PORT	1/8-27
"D"	M6X1,0	1/4-20
"E"	M6X1,0	1/4-20

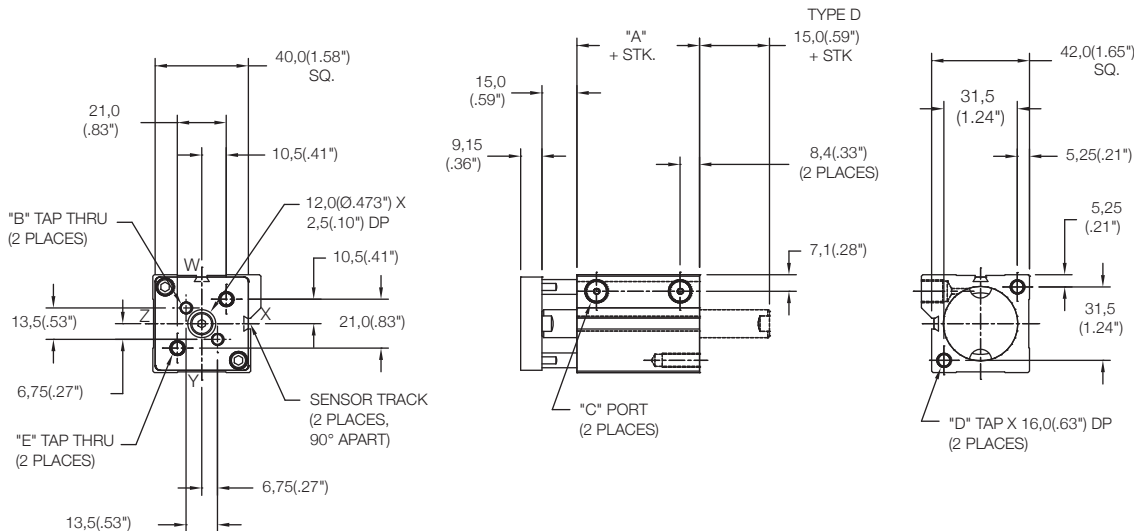

Side Mount Cylinder "MS"

MODEL	TYPE	STANDARD STROKES	"A"	PISTON AREA
LC	_D	15mm	37,5(1.48")	PUSH 8,04 cm ² (1.25 in ²)
		25mm		
		40mm		PULL 6,91 cm ² (1.07 in ²)
		50mm		

	Standard Threads	"EM" Option
"B"	M5X0,8	#10-32
"C"	G1/8 PORT	1/8-27
"D"	M4X0,7	#8-32
"E"	M6X1,0	1/4-20

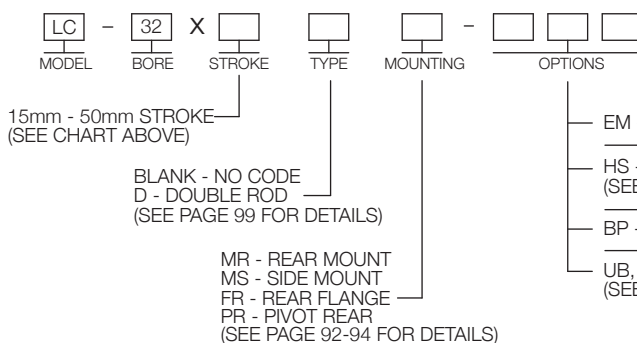
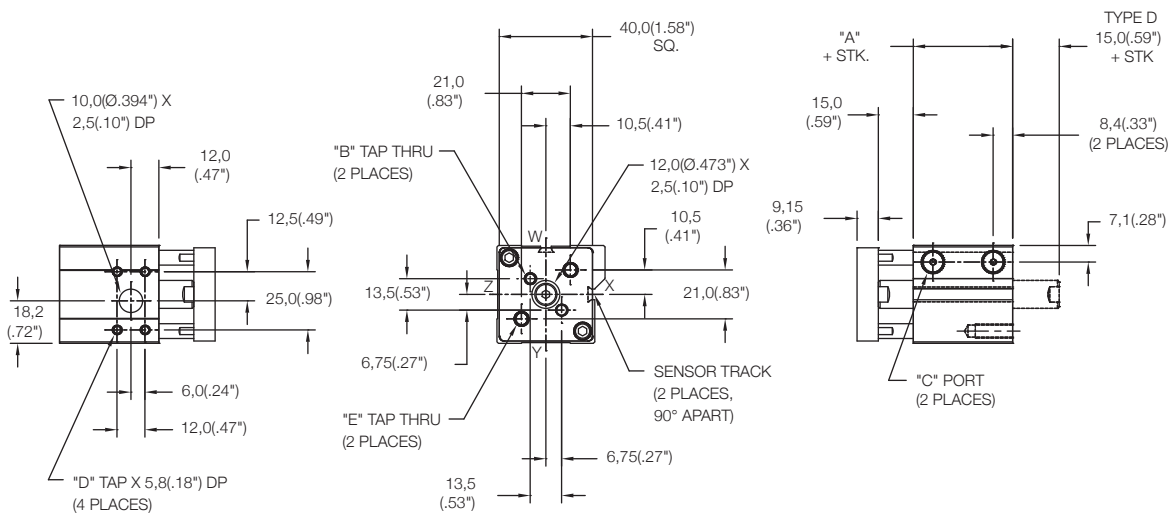

SENSORS SOLD SEPARATELY
SKS, SKP, SCS, SCP - SOLID STATE
LIMIT SENSORS
(SEE CATALOG PAGE 88 FOR DETAILS)

- EM - INCH THREADS & PORT OPTIONS:
- HS - HIGH TEMPERATURE SEALS OPTION:
(SEE CATALOG PAGE 97 FOR DETAILS)
- BP - BLANK TOOLING PLATE
- UB, UF, UR - URETHANE SHOCK PAD OPTION
(SEE CATALOG PAGE 97 FOR DETAILS)

Rear Mount Cylinder "MR"

MODEL	TYPE	STANDARD STROKES	"A"	PISTON AREA
LC	_D	15mm	45 (1.78")	PUSH 12,56 cm ² (1.95 in ²)
		25mm		
		40mm		PULL 10,55 cm ² (1.64 in ²)
		50mm		

	Standard Threads	"EM" Option
"B"	M6X1,0	1/4-20
"C"	G1/8 PORT	1/8-27
"D"	M6X1,0	1/4-20

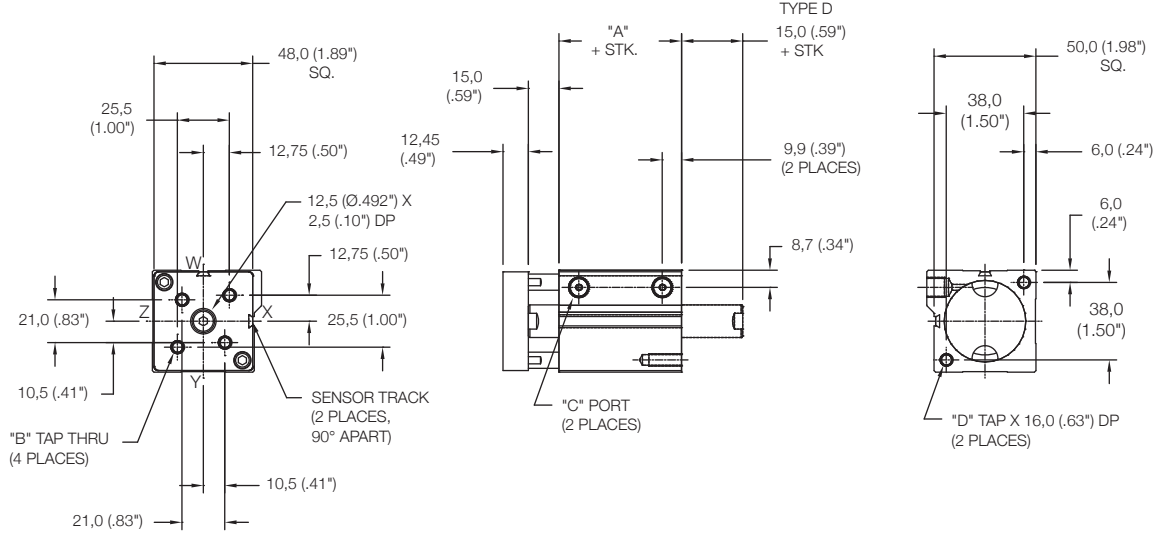

Side Mount Cylinder "MS"

MODEL	TYPE	STANDARD STROKES	"A"	PISTON AREA
LC	_D	15mm	45 (1.78")	PUSH 12,56 cm ² (1.95 in ²)
		25mm		
		40mm		PULL 10,55 cm ² (1.64 in ²)
		50mm		

	Standard Threads	"EM" Option
"B"	M6X1,0	1/4-20
"C"	G1/8 PORT	1/8-27
"D"	M4X0,7	#8-32

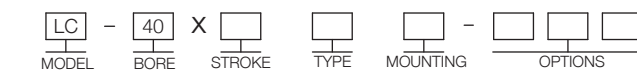
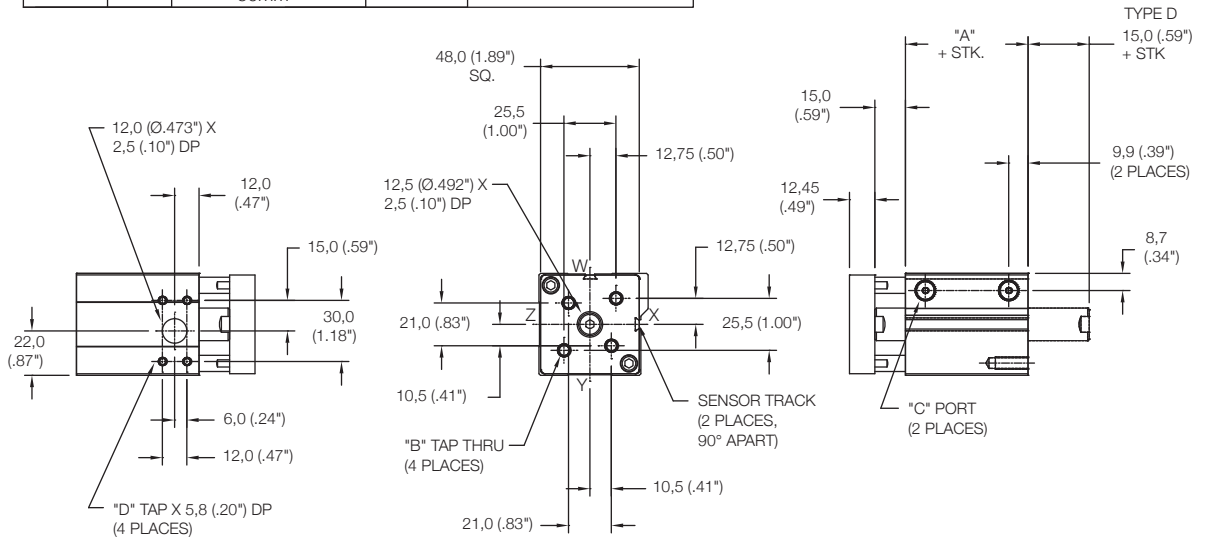

- 15mm - 50mm STROKE (SEE CHART ABOVE)
- BLANK - NO CODE
- D - DOUBLE ROD (SEE PAGE 99 FOR DETAILS)
- MR - REAR MOUNT
- MS - SIDE MOUNT
- FR - REAR FLANGE
- PR - PIVOT REAR (SEE PAGE 92-94 FOR DETAILS)

SENSORS SOLD SEPARATELY
 SKS, SKP, SCS, SCP - SOLID STATE
 LIMIT SENSORS
 (SEE CATALOG PAGE 88 FOR DETAILS)

- EM - INCH THREADS & PORT OPTIONS:
- HS - HIGH TEMPERATURE SEALS OPTION:
 (SEE CATALOG PAGE 97 FOR DETAILS)
- BP - BLANK TOOLING PLATE
- UB, UF, UR - URETHANE SHOCK PAD OPTION
 (SEE CATALOG PAGE 97 FOR DETAILS)

Rear Mount Cylinder "MR"

MODEL	TYPE	STANDARD STROKES	"A"	PISTON AREA
LC	_,D	15mm	48,5(1.91")	PUSH 19,63 cm ² (3.04 in ²) PULL 17,62 cm ² (2.73 in ²)
		25mm		
		40mm		
		50mm		
		75mm		

	Standard Threads	"EM" Option
"B"	M6X1,0	1/4-20
"C"	G1/8 PORT	1/8-27
"D"	M8X1,25	5/16-18
"E"	M8X1,25	5/16-18

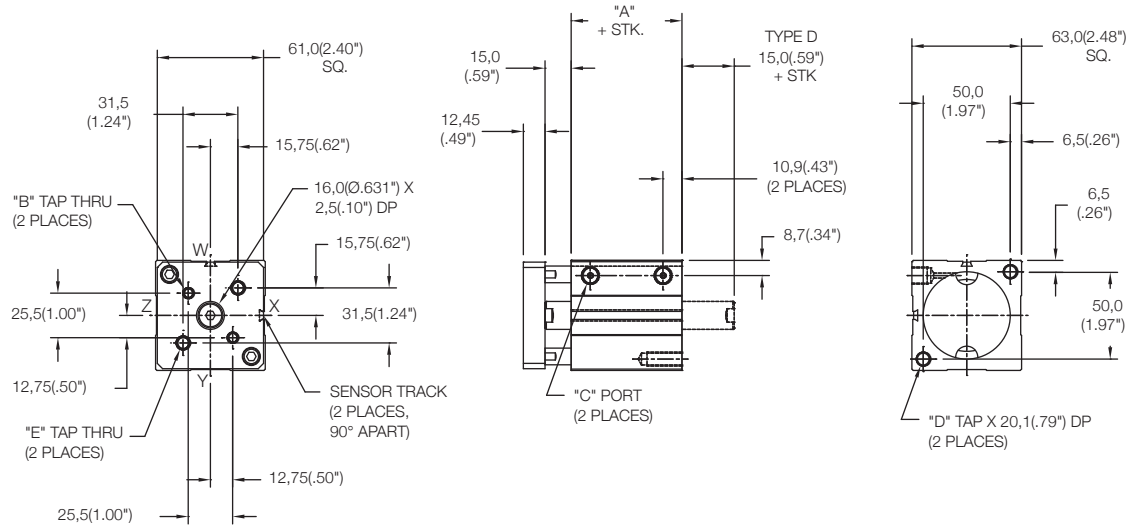

Side Mount Cylinder "MS"

MODEL	TYPE	STANDARD STROKES	"A"	PISTON AREA
LC	_,D	15mm	48,5(1.91")	PUSH 19,63 cm ² (3.04 in ²) PULL 17,62 cm ² (2.73 in ²)
		25mm		
		40mm		
		50mm		
		75mm		

	Standard Threads	"EM" Option
"B"	M6X1,0	1/4-20
"C"	G1/8 PORT	1/8-27
"D"	M5X0,8	#10-32
"E"	M8X1,25	5/16-18

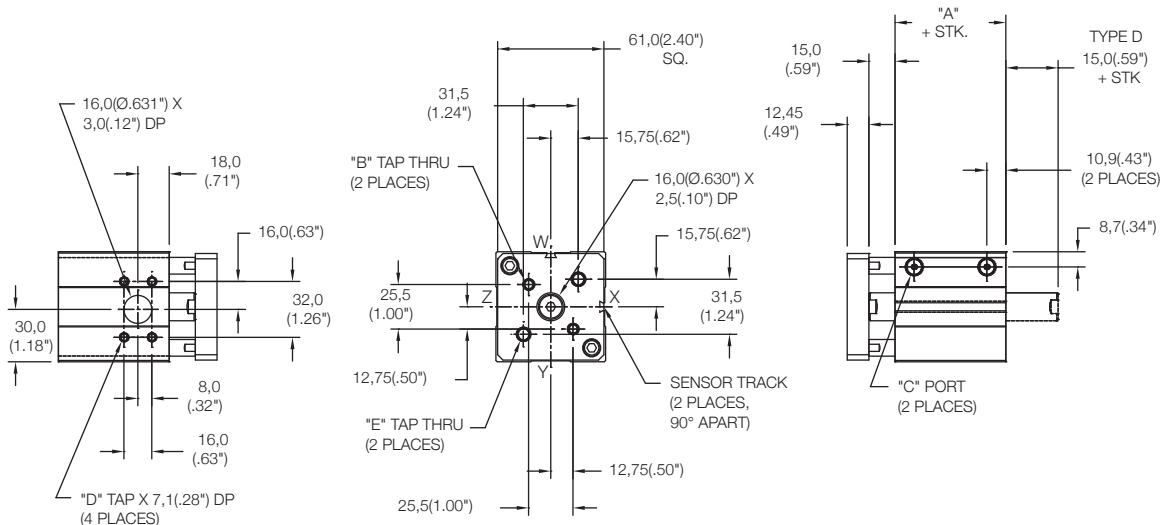

LC - MODEL 50 - BORE X STROKE TYPE MOUNTING - OPTIONS

15mm - 75mm STROKE
(SEE CHART ABOVE)

BLANK - NO CODE
D - DOUBLE ROD
(SEE PAGE 99 FOR DETAILS)

MR - REAR MOUNT
MS - SIDE MOUNT
FR - REAR FLANGE
PR - PIVOT REAR
(SEE PAGE 92-94 FOR DETAILS)

www.mfcp.com

SENSORS SOLD SEPARATELY
SKS, SKP, SCS, SCP - SOLID STATE
LIMIT SENSORS
(SEE CATALOG PAGE 88 FOR DETAILS)

EM - INCH THREADS & PORT OPTIONS:

HS - HIGH TEMPERATURE SEALS OPTION:
(SEE CATALOG PAGE 97 FOR DETAILS)

BP - BLANK TOOLING PLATE

UB, UF, UR - URETHANE SHOCK PAD OPTION
(SEE CATALOG PAGE 97 FOR DETAILS)

Rear Mount Cylinder "MR"

MODEL	TYPE	STANDARD STROKES	"A"	PISTON AREA
LC	_D	15mm	57,0(2.25")	PUSH 31,17 cm ² (4.83 in ²) PULL 28,03 cm ² (4.34 in ²)
		25mm		
		40mm		
		50mm		
		75mm		

	Standard Threads	"EM" Option
"B"	M8X1,25	5/16-18
"C"	G1/8 PORT	1/8-27
"D"	M10X1,5	3/8-24

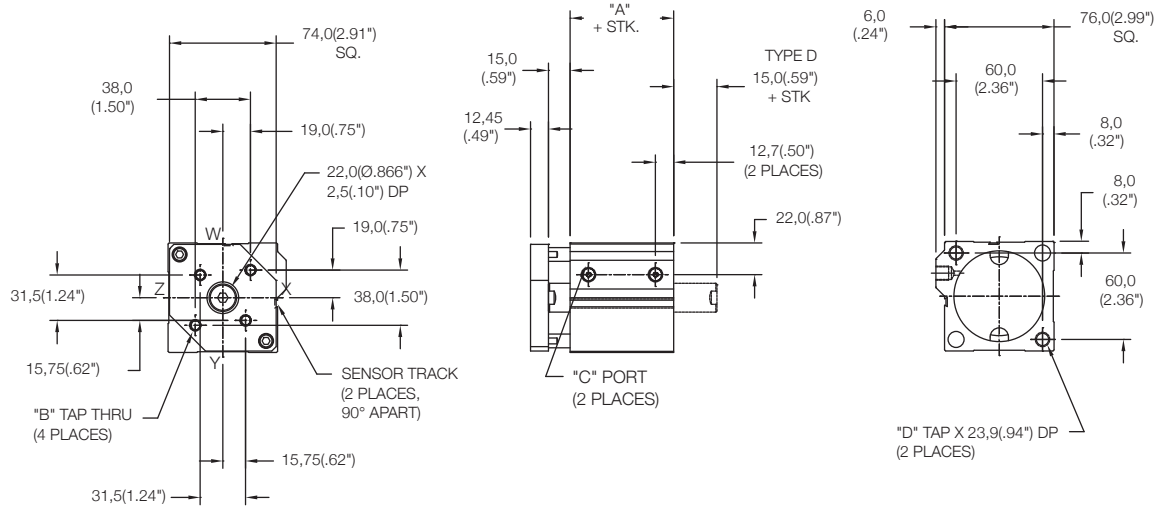

Side Mount Cylinder "MS"

MODEL	TYPE	STANDARD STROKES	"A"	PISTON AREA
LC	_D	15mm	57,0(2.25")	PUSH 31,17 cm ² (4.83 in ²) PULL 28,03 cm ² (4.34 in ²)
		25mm		
		40mm		
		50mm		
		75mm		

	Standard Threads	"EM" Option
"B"	M8X1,25	5/16-18
"C"	G1/8 PORT	1/8-27
"D"	M5X0,8	#10-32

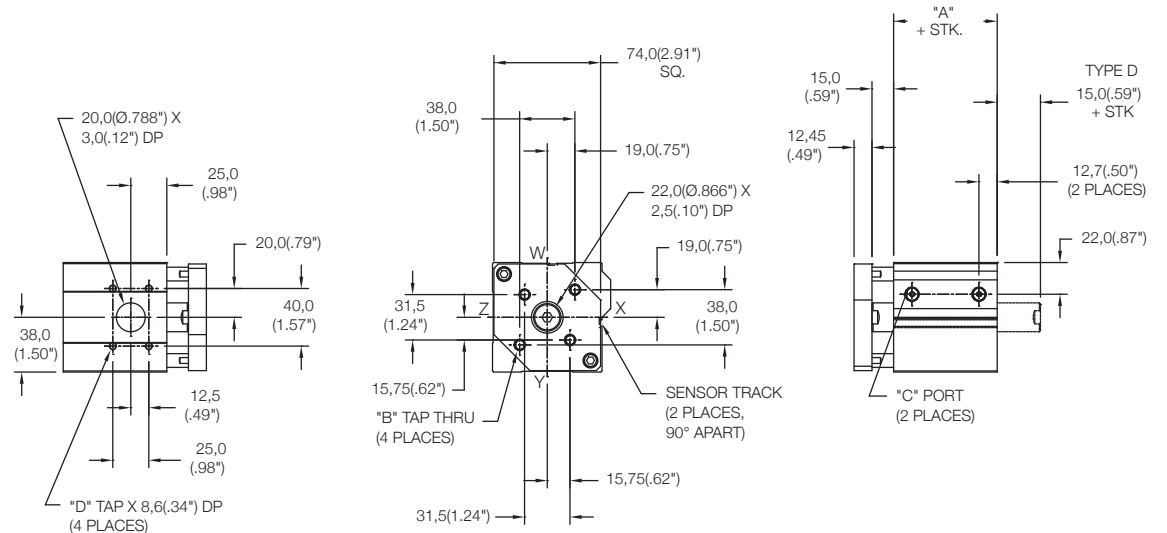

LC - 63 X [] [] - [] [] []
 MODEL BORE STROKE TYPE MOUNTING OPTIONS

15mm - 75mm STROKE
 (SEE CHART ABOVE)

BLANK - NO CODE
 D - DOUBLE ROD
 (SEE PAGE 99 FOR DETAILS)

MR - REAR MOUNT
 MS - SIDE MOUNT
 FR - REAR FLANGE
 PR - PIVOT REAR
 (SEE PAGE 92-94 FOR DETAILS)

SENSORS SOLD SEPARATELY
 SKS, SKP, SCS, SCP - SOLID STATE
 LIMIT SENSORS
 (SEE CATALOG PAGE 88 FOR DETAILS)

EM - INCH THREADS & PORT OPTIONS:

HS - HIGH TEMPERATURE SEALS OPTION:
 (SEE CATALOG PAGE 97 FOR DETAILS)

BP - BLANK TOOLING PLATE

UB, UF, UR - URETHANE SHOCK PAD OPTION
 (SEE CATALOG PAGE 97 FOR DETAILS)

HB SERIES

HEAVY DUTY BEARING BLOCK SLIDES

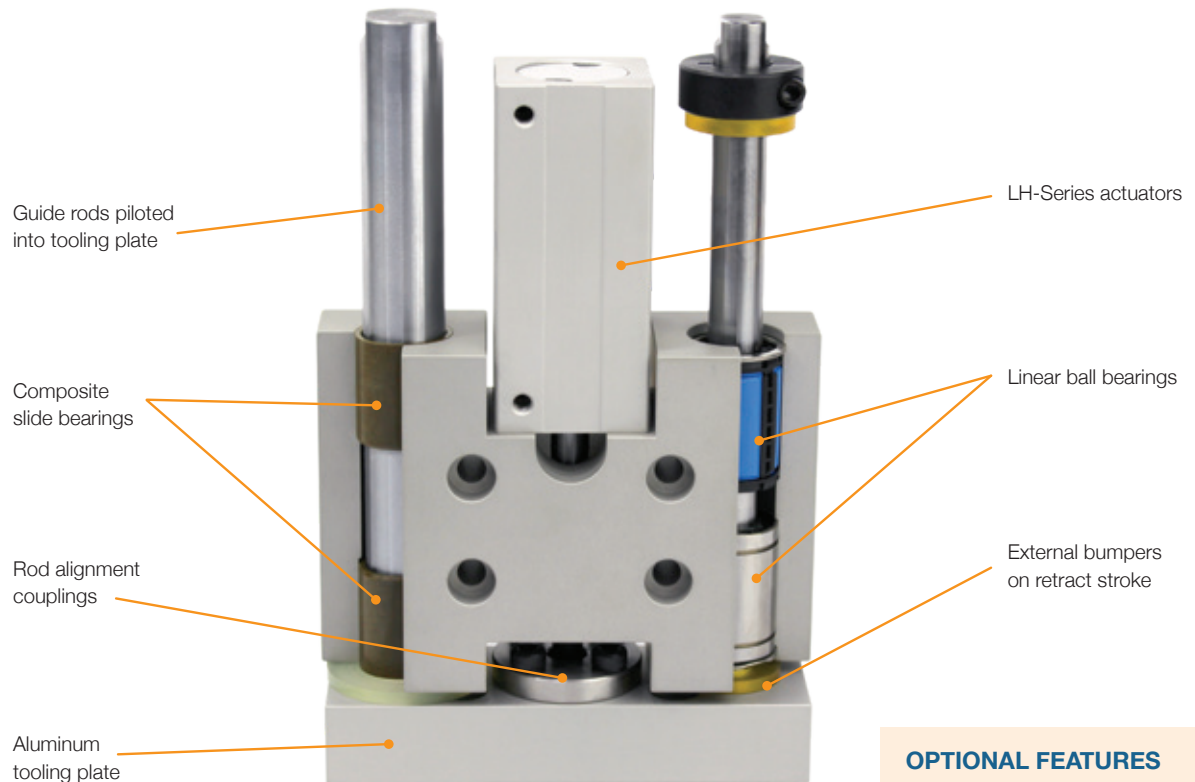

OPTIONAL FEATURES

- Magnetic pistons
- External extend stroke bumper
- Adjustable stroke collar

Common features

Nason's H-Block Series of pneumatic slides are heavy duty units designed for the most demanding applications. Rugged aluminum bearing housings are designed to accept Linear Ball Bearings or Composite Slide Bearings. The Linear Ball Bearings, in conjunction with case hardened 1566 steel guide rods, provide high load capacity, low deflection, and low friction. The Composite Slide Bearings allow for heavy loads, impact, and vibration due to the larger diameter chrome plated 1050 steel guide rods and bearing material.

H-Blocks are powered by Nason's proven heavy duty LH series actuators. The LH cylinders that power the slides are field

rebuildable. Magnetic pistons for position sensing are offered as options.

All units come with external bumpers on the retract stroke and an internal bumper on the extend stroke for noise reduction. External extend stroke bumpers and adjustable stroke collars are offered as options for intermediate strokes and impact resistance.

Heavy duty, thick aluminum tooling plates provide both thru mounting and tapped hole mounting. Guide rods are piloted into the tooling plates for rigidity and precision. All slides are designed with rod alignment couplings connecting the tooling plate to the cylinder rod to ensure maximum life for the LH cylinder.

How To Order

Example: H-Block Slide, 25mm Bore X 100mm Stroke, Composite Slide Bearings, Thru Mount, Magnetic Piston and Sensor Mounting Track, Inch Threads, Adjustable Extend Stroke/Urethane Shock Pads Extend, 1/8 NPT Ports.

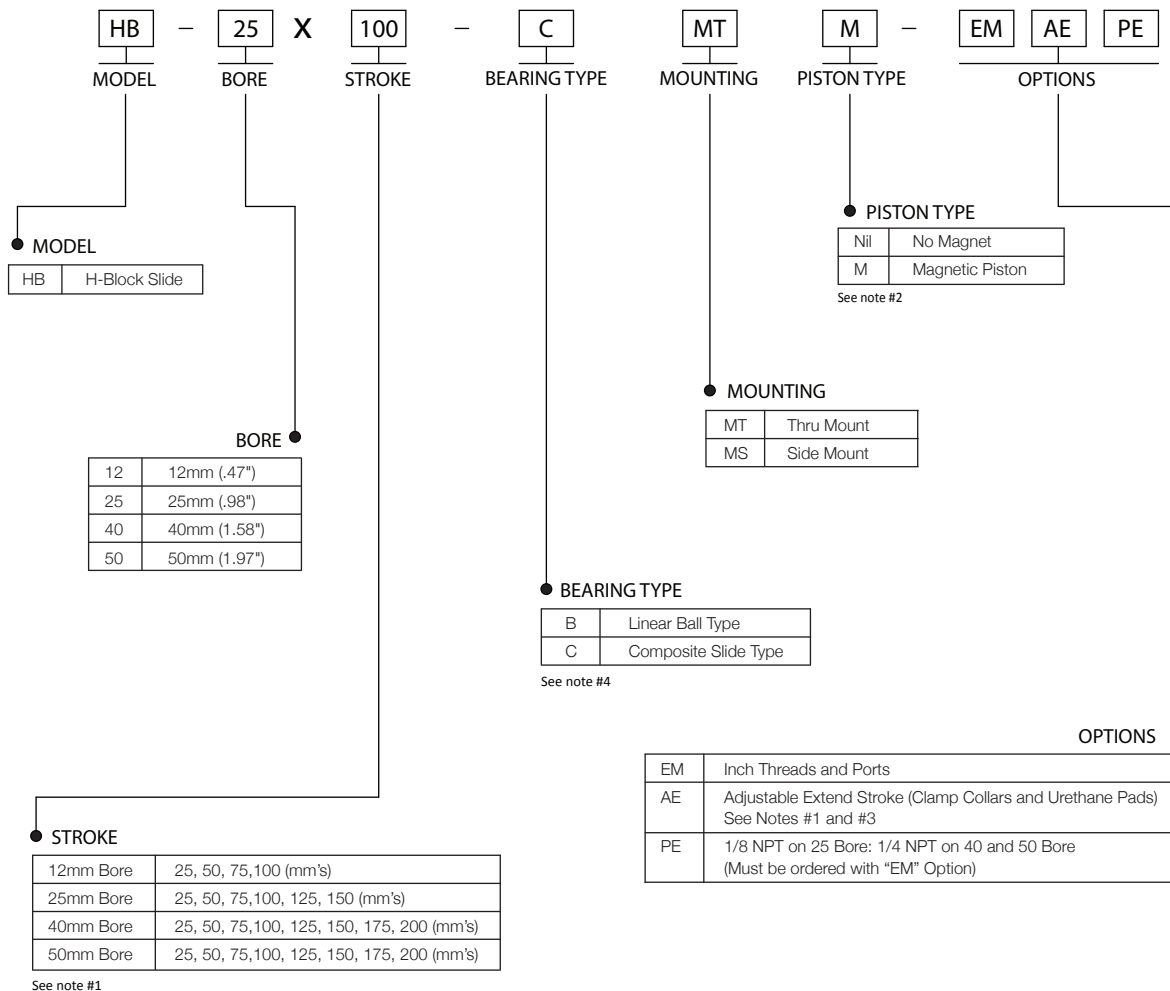

Note 1 - Drive cylinder is manufactured in 25mm stroke increments. For intermediate strokes, order the next longer standard stroke and the "AE" option to set intermediate stroke.
 Example: For a 32mm stroke, 25mm bore slide with linear ball bearings and thru mount, order HB-25X50-B-MT-AE and adjust collars for 32mm stroke.
 Note 2 - Magnetic Piston "M" adds magnet to piston and 1 sensor track on port side. For other track locations, multiple sensor tracks, etc. consult factory.
 Note 3 - Slides come with Urethane Shock Pads on the retract stroke as standard. For Urethane shock pads on extend stroke, order "AE" option and adjust collars so that shock pads engage.
 Note 4 - Linear ball bearings should not be used in vibration or impact applications, or applications where dirt, oil, or contamination can occur. For vibration and impact applications, or where contamination may occur, choose the Composite slide type bearings.
 Note 5 - Contact the factory for shock absorber options.

Action:	Double Acting
Media:	Air - Clean, Dry Or Lubricated
Pre-Lubricated at Factory:	Non-soap elastomer/PTFE thickener
Temp. Range:	-10C to 81C (14F to 178F)
Stroke Tolerance (Std):	+1,0mm/-0 (+0.04"/-0)

Piston Area Chart

Bore	Piston (Rod Extend)	Piston (Rod Retract)
12	1,13 cm ² (.18 in ²)	0,85 cm ² (.14 in ²)
25	4,91 cm ² (.76 in ²)	4,12 cm ² (.64 in ²)
40	12,56 cm ² (1.95 in ²)	10,55 cm ² (1.64 in ²)
50	19,63 cm ² (3.04 in ²)	17,62 cm ² (2.73 in ²)

Cylinder Ratings

Min. Operating Pressure	Max. Operating Pressure	Max. Piston Speed (See note #4)
0.10 MPa (14.5 PSI)	1.0 MPa (150 PSI)	200 mm/s (7.9 in/s)
0.07 MPa (10 PSI)	1.4 MPa (200 PSI)	400 mm/s (15.7 in/s)
0.07 MPa (10 PSI)	1.4 MPa (200 PSI)	400 mm/s (15.7 in/s)
0.07 MPa (10 PSI)	1.4 MPa (200 PSI)	400 mm/s (15.7 in/s)

Stock Stroke Table

Bore	Standard Stroke Lengths
12	25mm (.98"), 50mm (1.97"), 75mm (2.95"), 100mm (3.94")
25	25mm (.98"), 50mm (1.97"), 75mm (2.95"), 100mm (3.94"), 125mm (4.92"), 150mm (5.91")
40	25mm (.98"), 50mm (1.97"), 75mm (2.95"), 100mm (3.94"), 125mm (4.92"), 150mm (5.91"), 175mm (6.89"), 200mm (7.87")
50	25mm (.98"), 50mm (1.97"), 75mm (2.95"), 100mm (3.94"), 125mm (4.92"), 150mm (5.91"), 175mm (6.89"), 200mm (7.87")

Cylinder Output Force Formula

Piston Area x Pressure = Output Force
Piston Area(in ²) x Pressure(PSI) = lbf (Pounds Force)
Piston Area(cm ²) x Pressure(kg/cm ²) = kgf (Kilograms Force)
Piston Area(cm ²) x Pressure(kg/cm ²) x 9.8 = Newtons
Piston Area(cm ²) x Pressure(Bar) x 10 = Newtons
Piston Area(cm ²) x Pressure(Bar) x 1.02 = kgf (Kilograms Force)

Note 1 - Drive cylinder is manufactured in 25mm stroke increments. For intermediate strokes, order the next longer standard stroke and the "AE" option to set intermediate stroke.

Example: For a 32mm stroke, 25mm bore slide with linear ball bearings and thru mount, order HB-25X50-B-MT-AE and adjust collars for 32mm stroke.

Note 2 - For other temperature requirements, consult factory for a custom option.

Note 3 - Slides come with Urethane Shock Pads on the retract stroke as standard.

Note 4 - Maximum speeds are with no loads. Speeds may need to be reduced based on loads and applications. Always consider the use of flow controls and/or external shock absorbers to avoid damage to the slide.

Note 5 - Contact the factory for shock absorber options.

"B" - Linear Ball Bearing Tooling Plate Displacement

(Reference Values)

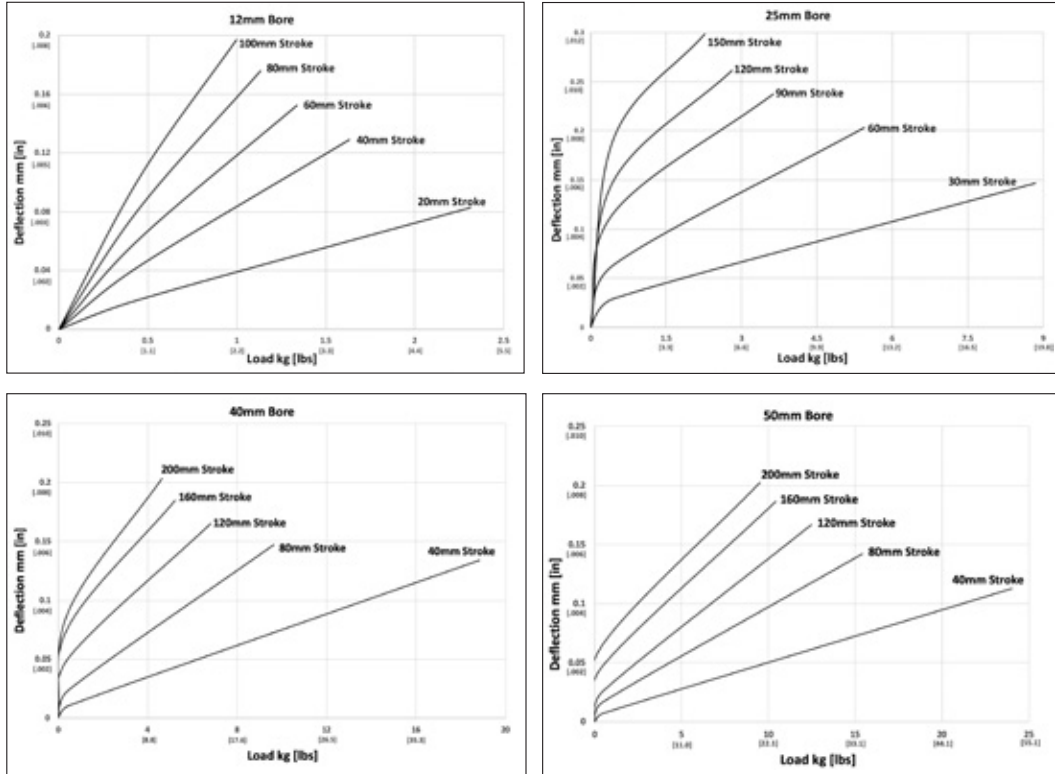
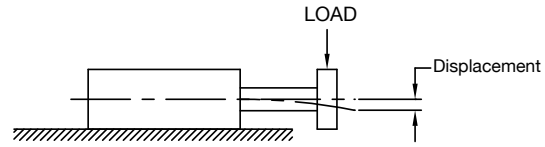

Horizontal Mounting Load Charts

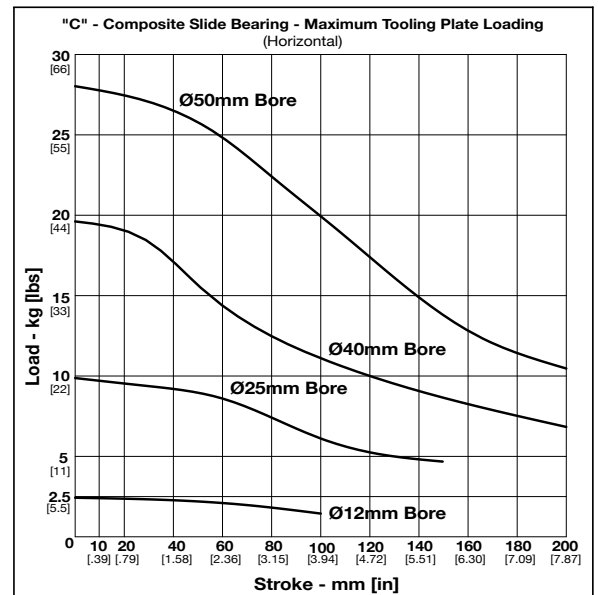
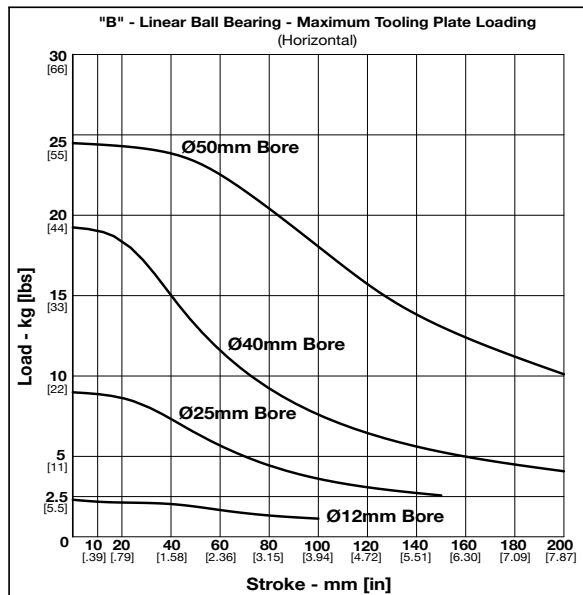
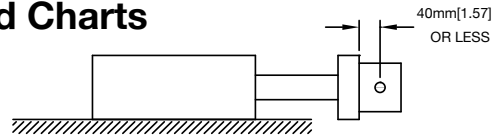

Note 1 - Flow controls and/or shock absorbers are strongly recommended when approaching maximum values. Consult the factory for shock absorber options.
 Note 2 - Loads are for 200mm/sec (7.87in/sec) piston speed or less.

Thru Mount "MT"

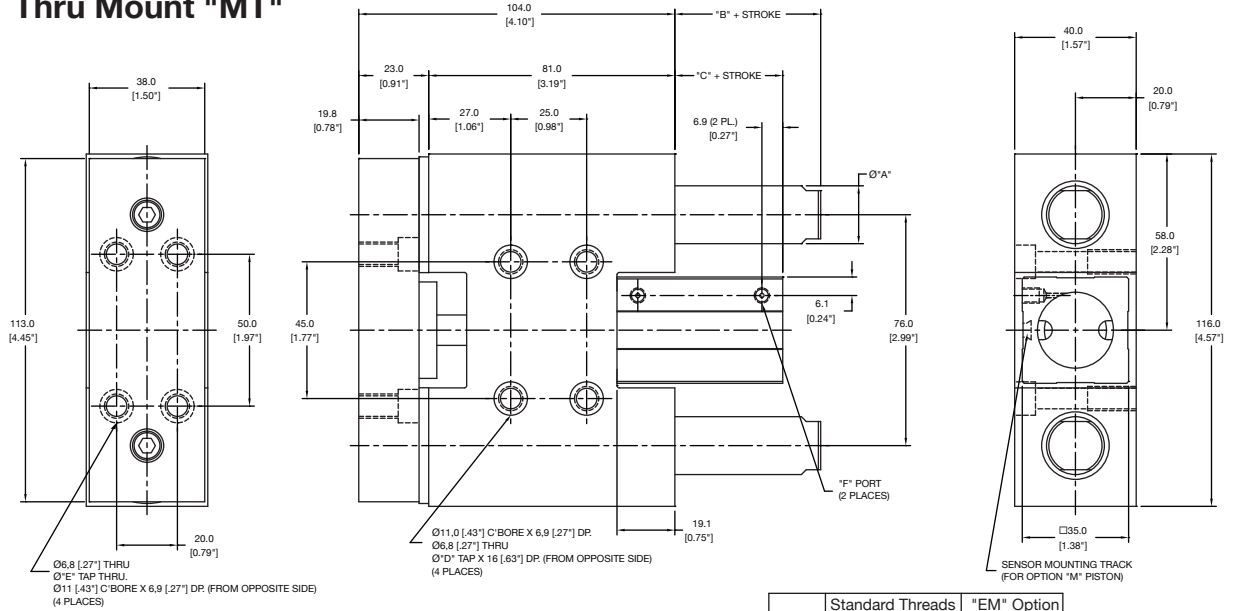

BEARING	"A"	"B"	PISTON	"C"	PISTON	"C"
"B" - BALL TYPE	12,7 (.50")	23,0 (.91")	Non-Mag	10,5 (.41")	Mag	15,5 (.61")
"C" - COMPOSITE TYPE	19,05 (.75")	23,0 (.91")	Non-Mag	10,5 (.41")	Mag	15,5 (.61")

	Standard Threads	"EM" Option
"D"	M8x1,25	5/16-18
"E"	M8x1,25	5/16-18
"F"	M5X0,8	#10-32
"G"	M6x1	1/4-20

Side Mount "MS"

(All dimensions not shown same as "MT")

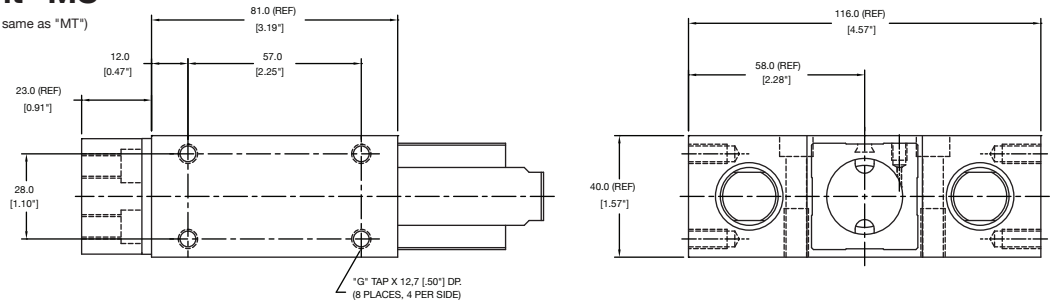

Option "AE"

(All dimensions not shown same as above)

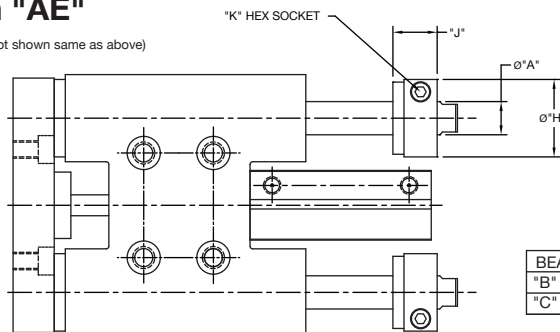

BEARING	"A"	"H"	"J"	"K"
"B" - BALL TYPE	12,7 (.50")	28,6 (1.13")	13,5 (.53")	9/64
"C" - COMPOSITE TYPE	19,05 (.75")	38,1 (1.50")	16,0 (.63")	3/16

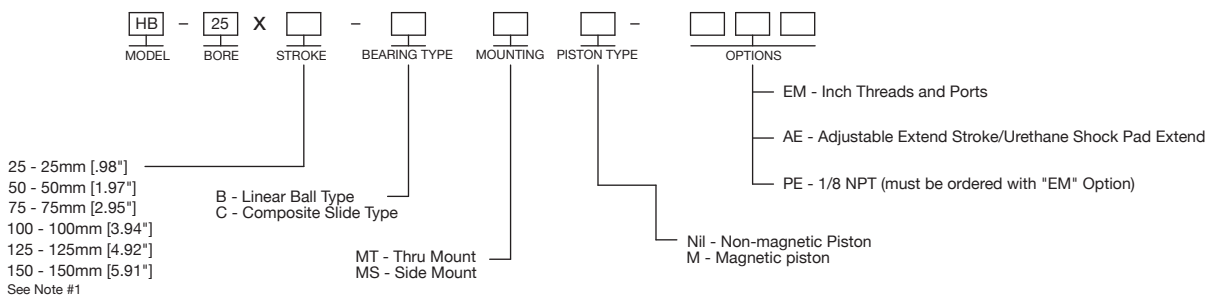

Note 1 - Drive cylinder is manufactured in 25mm stroke increments. For intermediate strokes, order the next longer standard stroke and the "AE" option to set intermediate stroke.
Note 2 - Contact the factory for shock absorber option.

Thru Mount "MT"

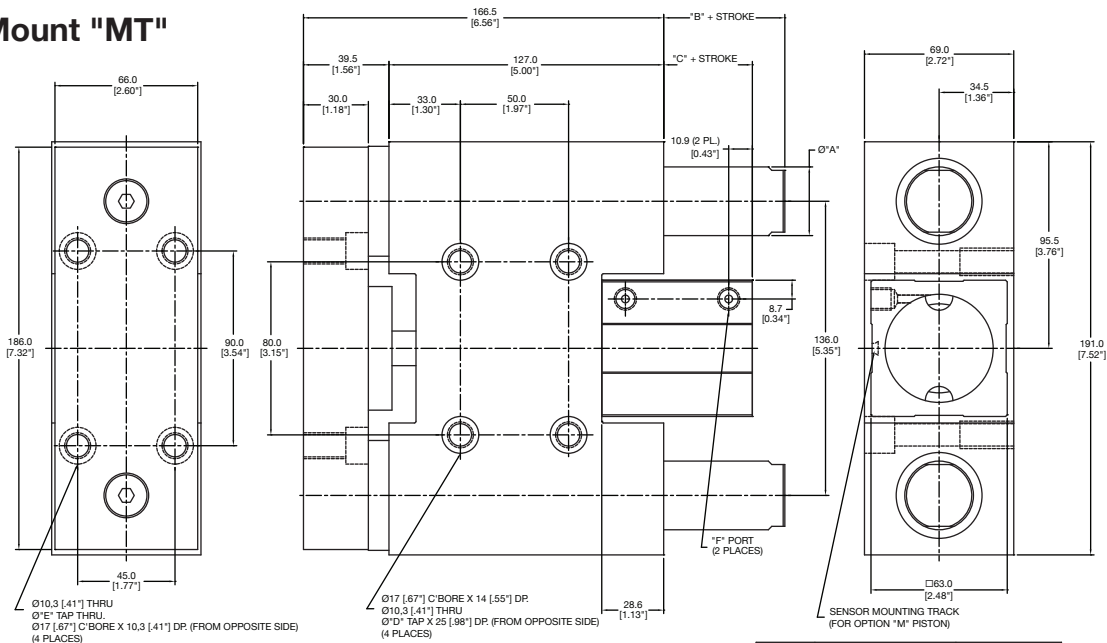

BEARING	"A"	"B"	PISTON	"C"	PISTON	"C"
"B" - BALL TYPE	25,4 (1.0")	31,0 (1.22")	Non-Mag	16,0 (.63")	Mag	21,0 (.83")
"C" - COMPOSITE TYPE	31,75 (1.25")	31,0 (1.22")	Non-Mag	16,0 (.63")	Mag	21,0 (.83")

	Standard Threads	"EM" Option
"D"	M12x1,75	1/2-13
"E"	M12x1,75	1/2-13
"F"	G1/8	1/8 NPT
"G"	M10x1,5	3/8-24

Side Mount "MS"

(All dimensions not shown same as "MT")

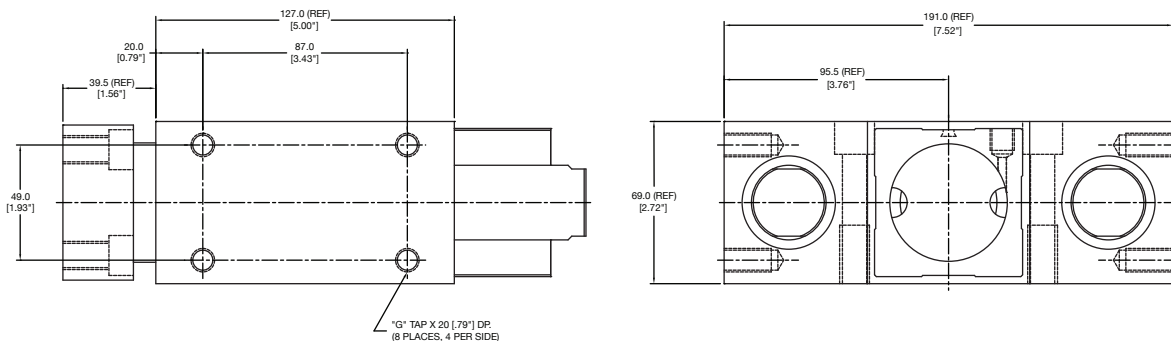

Option "AE"

(All dimensions not shown same as above)

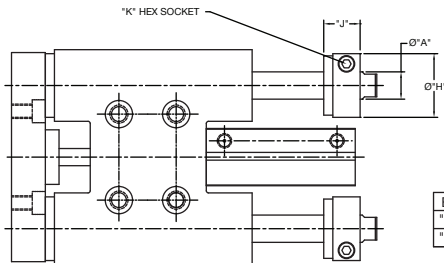

BEARING	"A"	"H"	"J"	"K"
"B" - BALL TYPE	25,4 (1.0")	44,5 (1.75")	22,2 (.88")	3/16
"C" - COMPOSITE TYPE	31,75 (1.25")	52,4 (2.06")	22,2 (.88")	3/16

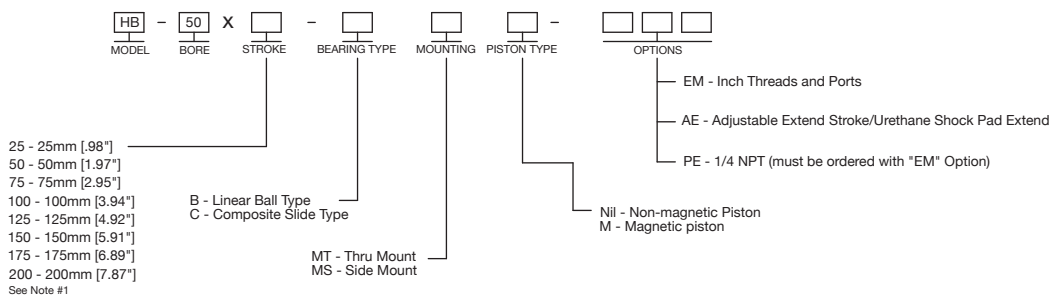

SC SERIES STOPPER CYLINDERS

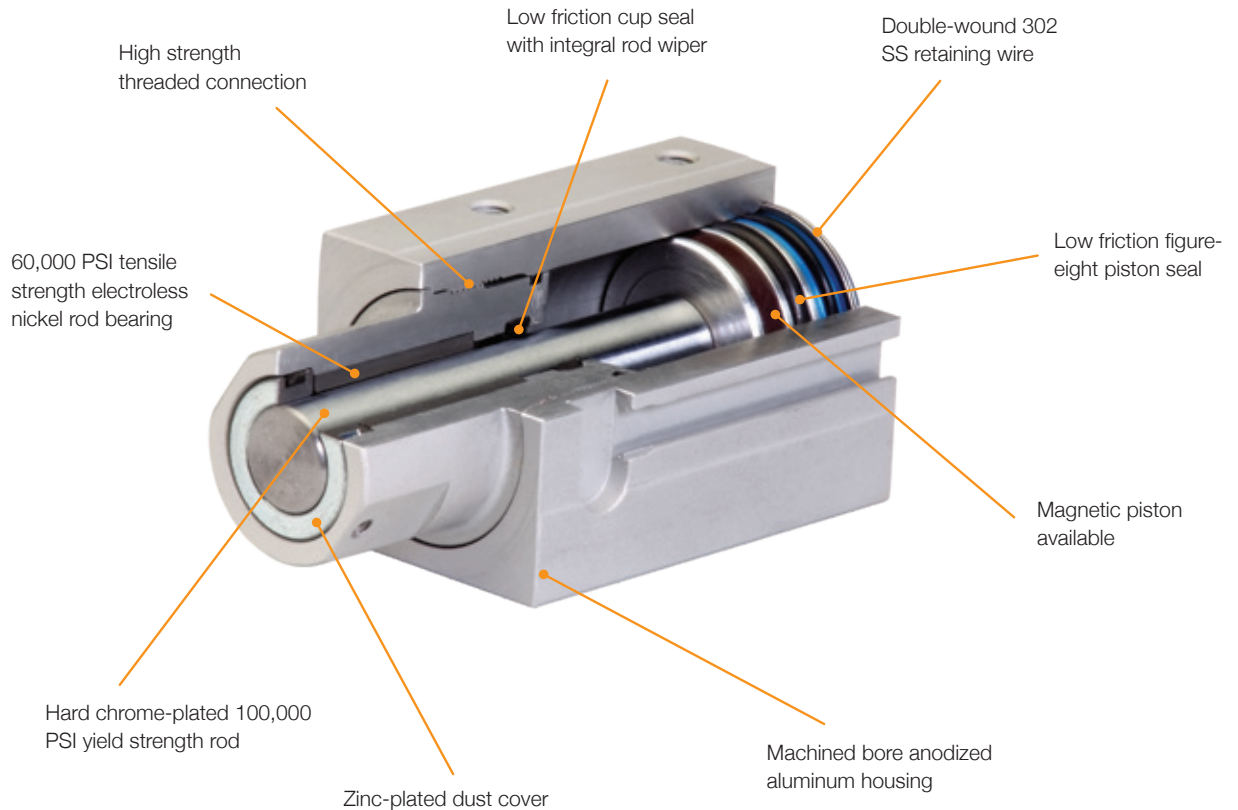

Common Features

Nason's SC series stopper cylinders were designed for today's demanding conveyor systems. With more power in a smaller package, the SC series stopper cylinder is offered in seven different mounting styles with three different rod end configurations to fit into almost any design situation.

Compact Size

Nason's SC series cylinders were designed with today's conveyor systems in mind. Five bore sizes with a variety of strokes and rod end options ensure a perfect fit for each application. Nason is able to fit a larger bore size into the same package as comparable competitive products.

Rugged Construction

The SC series incorporates 60,000 PSI tensile strength bearings with an oversized 100,000 PSI yield strength rod for maximum stopping power.

Versatile Design

The SC series stopper cylinders are metric in design (bore & rod size). They are offered in inch or metric mounting and porting. Five different threaded mounting options and two different flange mounting options ensure an exact fit into today's tight space requirements. Due to their 100% machined design, they are easily customized by Nason.

Rebuildable

All SC series cylinders are field-rebuildable.

How to Order

Example:

Part Number: SC-32X15WFS-EMHS

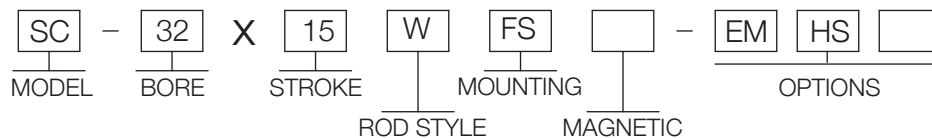

MODEL
SC - Stopper Cylinder

BORE
20 - 20mm (.79")
25 - 25mm (.98")
32 - 32mm (1.26")
40 - 40mm (1.58")
50 - 50mm (1.97")

STROKE	
20mm Bore	10 - 10mm Stroke
	15 - 15mm Stroke
25mm Bore	10 - 10mm Stroke
	15 - 15mm Stroke
	20 - 20mm Stroke
32mm Bore	10 - 10mm Stroke
	15 - 15mm Stroke
	20 - 20mm Stroke
40mm Bore	20 - 20mm Stroke
	25 - 25mm Stroke
	30 - 30mm Stroke
50mm Bore	20 - 20mm Stroke
	25 - 25mm Stroke
	30 - 30mm Stroke

ROD STYLE
BLANK (No Code) - Round Rod
F - Flat Rod
W - Flat Rod with Roller

MOUNTING
MF - Threads on Front Face (Rod End)
MR - Threads on Rear Face (Opposite Rod)
MB - Threads on Both Faces
MT - Drilled Through and Counterbored for Bolt Clearance
MS - Threads on Side of Cylinder Body
FR - Flange on Rear Face (Opposite Rod)
FS - Flange on Side of Cylinder Body

MAGNETIC
BLANK (No Code) - Standard "NO MAGNET" Piston
M - Magnetic Piston and Sensor Mounting

OPTIONS
EM - Inch Threads (Mounting and Ports)
HS - High Temperature Seals -10°C to 150°C (0°F to 302°F)
UR - Urethane Shock Pad Rear (Opposite Rod)

Operating Media: Air (Clean, Dry or Lubricated)
 Maximum Operating Pressure: 17 Bar (250 PSI)
 Operating Temperature: -10°C to 95°C (0°F to 200°F)
 Packing: Buna N
 Lubrication: PTFE impregnated grease
 Stroke Tolerance: +1,0mm/-0mm (+0.04"/-0")

Unit Weights kg (lbs)

BORE	STROKE				
	10	15	20	25	30
20	0.15 (.34)	0.16 (.36)	—	—	—
25	0.21 (.47)	0.23 (.50)	0.24 (.53)	—	—
32	0.43 (.94)	0.45 (1.0)	0.48 (1.06)	—	—
40	—	—	0.74 (1.67)	0.79 (1.75)	0.83 (1.83)
50	—	—	1.10 (2.43)	1.15 (2.53)	1.19 (2.63)

Operating Ranges

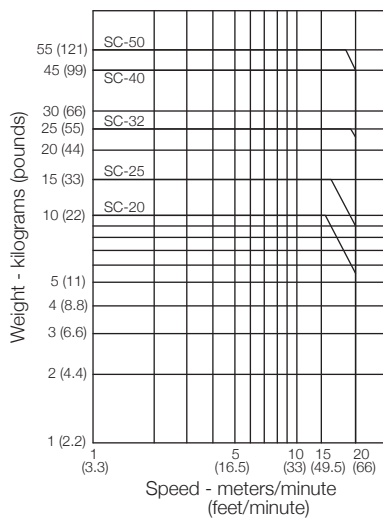

Minimum Operating Pressure for Load

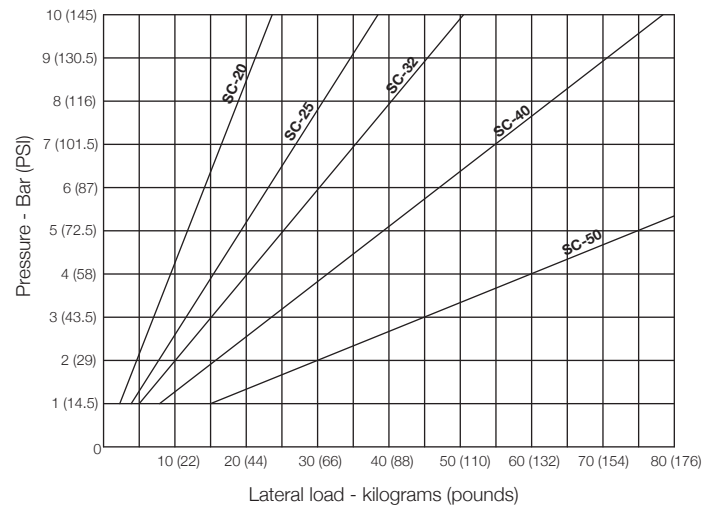

Magnetic Front Mount Cylinder "MF"

MODEL	STANDARD STROKES	"A"	PISTON AREA
SC	10mm	38,0 (1.50")	PUSH 3,14 cm ² (0.48 in ²)
	15mm		PULL 2,32 cm ² (0.36 in ²)

	Standard Threads	"EM" Option
"B"	M5X0,8	#10-32
"C"	M5X0,8	#10-32

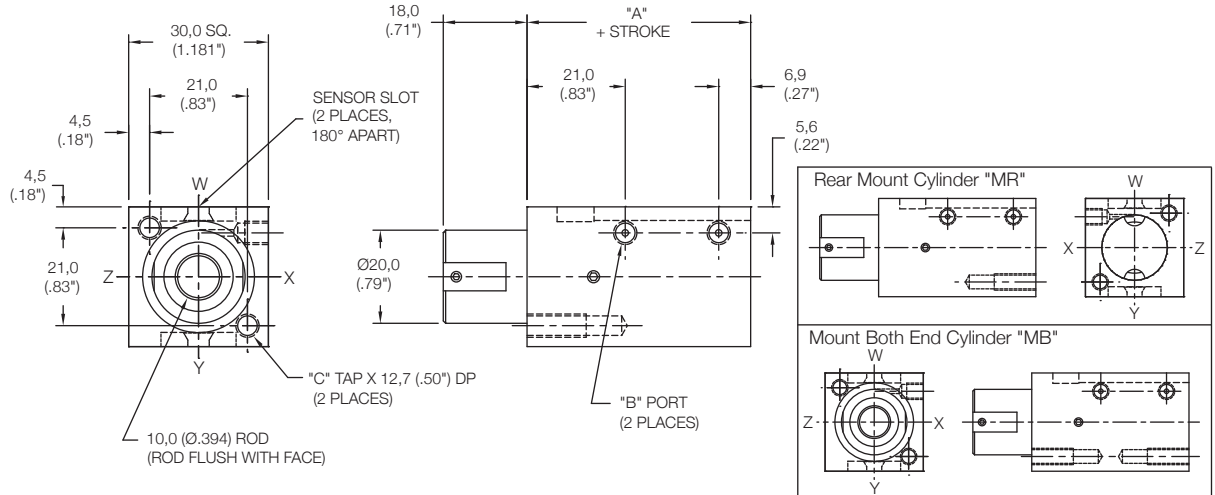

Magnetic Thru Mount Cylinder "MT"

MODEL	STANDARD STROKES	"A"	PISTON AREA
SC	10mm	38,0 (1.50")	PUSH 3,14 cm ² (0.48 in ²)
	15mm		PULL 2,32 cm ² (0.36 in ²)

	Standard Threads	"EM" Option
"B"	M5X0,8	#10-32

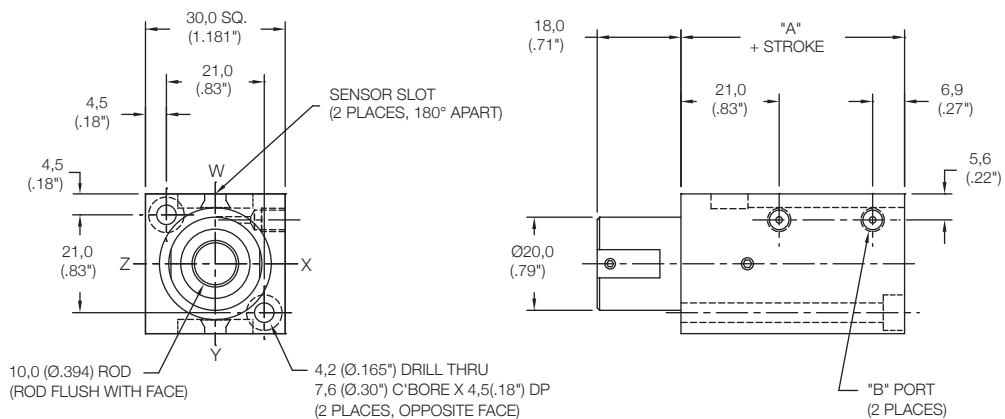

10 - 10mm STROKE
15 - 15mm STROKE

BLANK (NO CODE) - ROUND ROD (SHOWN)
F - FLAT ROD (SEE PAGE 127)
W - FLAT ROD WITH ROLLER (SEE PAGE 127)

EM - INCH THREADS & PORTS
HS - HIGH TEMP SEALS (SEE PAGE 97)
UR - URETHANE SHOCK PAD REAR (SEE PAGE 97)

SENSORS SOLD SEPARATELY
SKS, SKP, SCS, SCP - SOLID STATE LIMIT SENSORS
(SEE PAGE 88 FOR DETAILS)

MB - BOTH END MOUNTS
MF - FRONT MOUNT
MR - REAR MOUNT
MT - THRU MOUNT
FR - FLANGE ON REAR FACE (SEE PAGE 128)

**Non Magnetic
Side Mount Cylinder "MS"**

MODEL	STANDARD STROKES	"A"	PISTON AREA
SC	10mm	38,0 (1.50")	PUSH 3,14 cm ² (0.48 in ²)
	15mm		PULL 2,32 cm ² (0.36 in ²)

	Standard Threads	"EM" Option
"B"	M5X0,8	#10-32
"C"	M4X0,7	#8-32

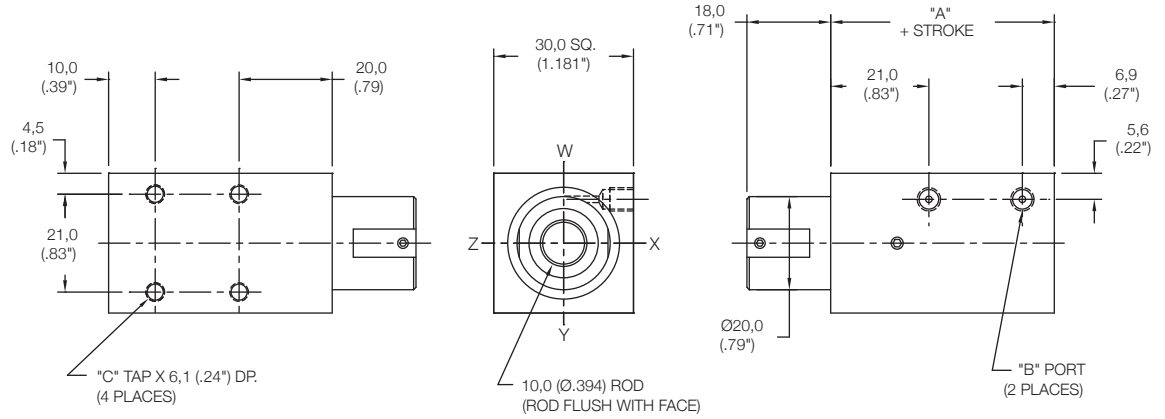

**Magnetic
Side Mount Cylinder "MS"**

MODEL	STANDARD STROKES	"A"	PISTON AREA
SC	10mm	38,0 (1.50")	PUSH 3,14 cm ² (0.48 in ²)
	15mm		PULL 2,32 cm ² (0.36 in ²)

	Standard Threads	"EM" Option
"B"	M5X0,8	#10-32
"C"	M4X0,7	#8-32

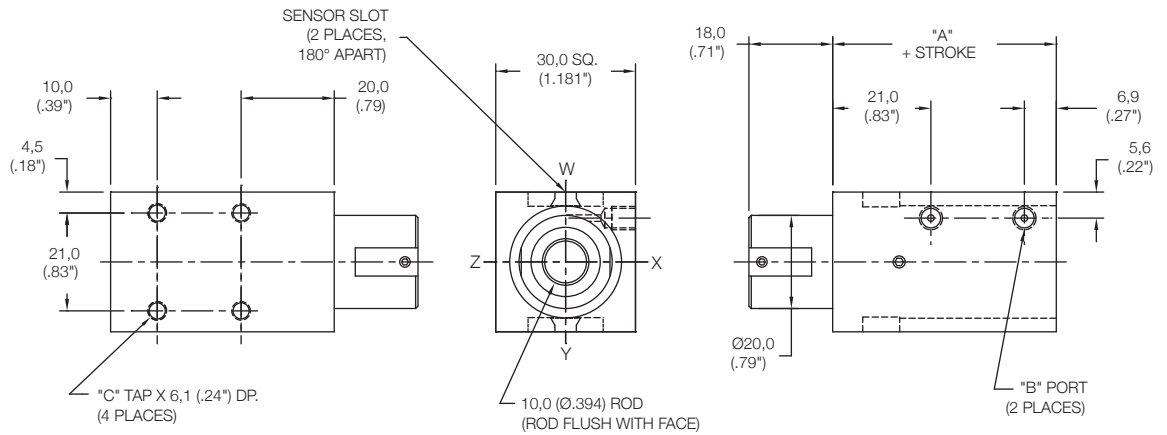

10 - 10mm STROKE
15 - 15mm STROKE

MS - SIDE THREADS
FS - SIDE FLANGES
(SEE PAGE 128)

EM - INCH THREADS & PORTS
HS - HIGH TEMP SEALS (SEE PAGE 97)
UR - URETHANE SHOCK PAD REAR
(SEE PAGE 97)

BLANK (NO CODE) - ROUND ROD (SHOWN)
F - FLAT ROD (SEE PAGE 127)
W - FLAT ROD WITH ROLLER (SEE PAGE 127)

BLANK (NO CODE) - STANDARD "NO MAGNET" PISTON
M - MAGNETIC PISTON AND SENSOR MOUNTING SLOTS

SENSORS SOLD SEPARATELY
SKS, SKP, SCS, SCP - SOLID STATE
LIMIT SENSORS
(SEE PAGE 88 FOR DETAILS)

Non Magnetic Front Mount Cylinder "MF"

MODEL	STANDARD STROKES	"A"	PISTON AREA
SC	10mm	38,0 (1.50")	PUSH 4,91 cm ² (0.76 in ²) PULL 3,81 cm ² (0.59 in ²)
	15mm		
	20mm		

	Standard Threads	"EM" Option
"B"	M5X0,8	#10-32
"C"	M5X0,8	#10-32

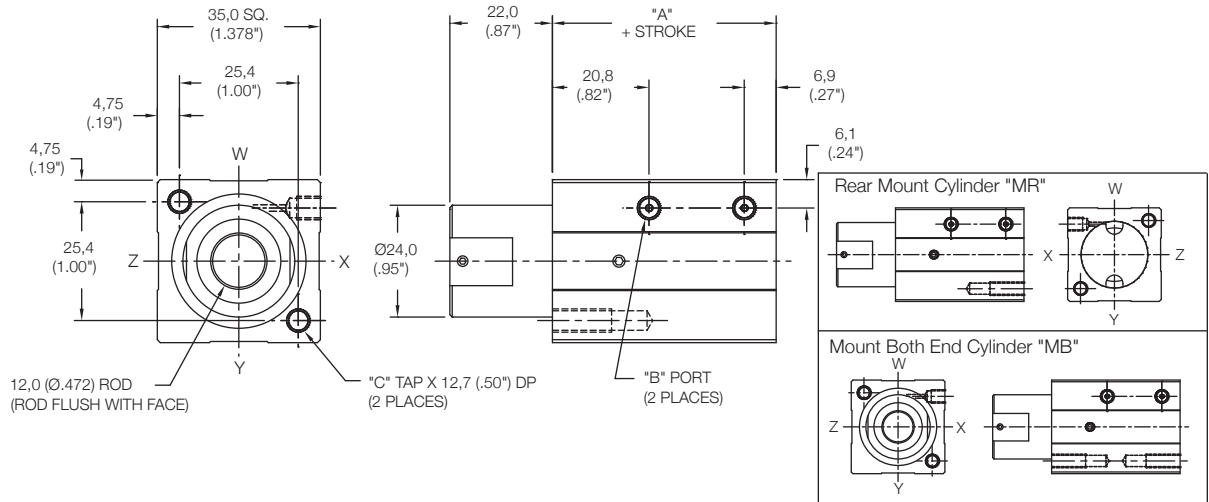

Non Magnetic Thru Mount Cylinder "MT"

MODEL	STANDARD STROKES	"A"	PISTON AREA
SC	10mm	38,0 (1.50")	PUSH 4,91 cm ² (.76 in ²) PULL 3,81 cm ² (.59 in ²)
	15mm		
	20mm		

	Standard Threads	"EM" Option
"B"	M5X0,8	#10-32

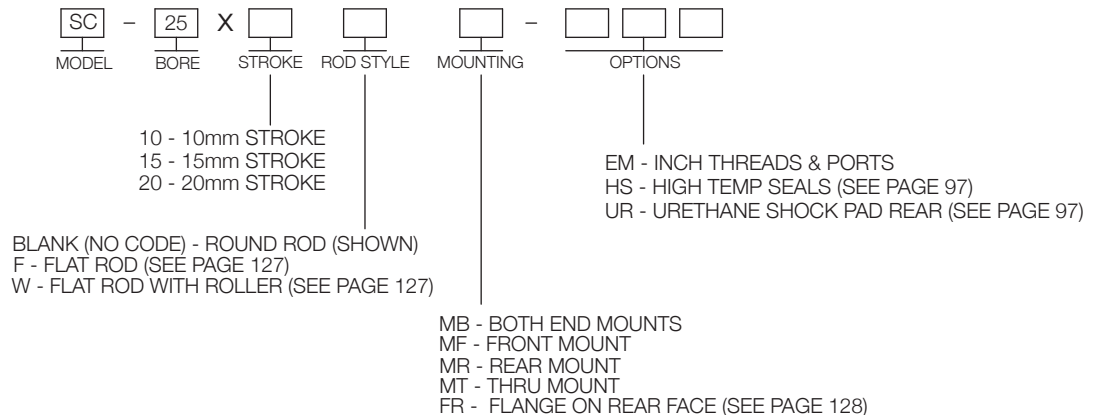
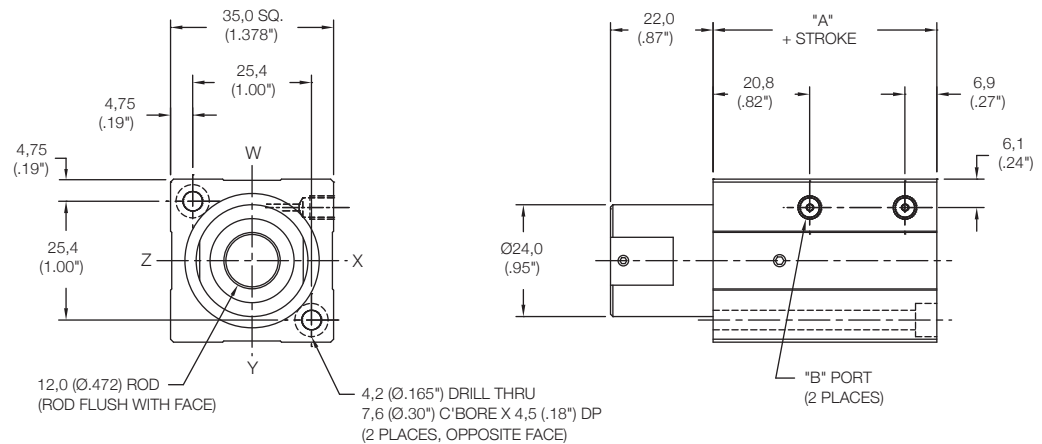

Magnetic Front Mount Cylinder "MF"

MODEL	STANDARD STROKES	"A"	PISTON AREA
SC	10mm	38,0 (1.50")	PUSH 4,91 cm ² (0.76 in ²) PULL 3,81 cm ² (0.59 in ²)
	15mm		
	20mm		

	Standard Threads	"EM" Option
"B"	M5X0,8	#10-32
"C"	M5X0,8	#10-32

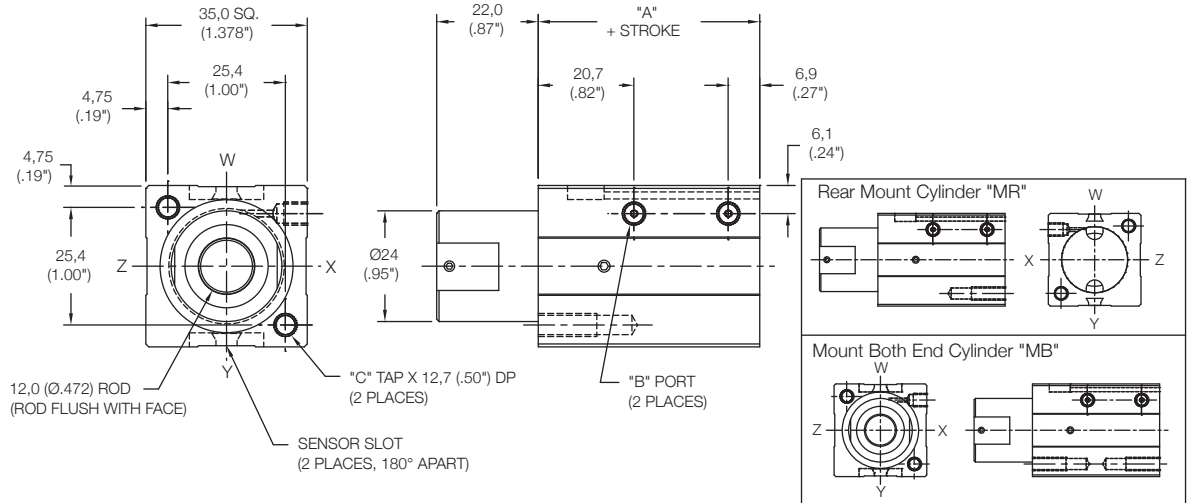

Magnetic Thru Mount Cylinder "MT"

MODEL	STANDARD STROKES	"A"	PISTON AREA
SC	10mm	38,0 (1.50")	PUSH 4,91 cm ² (.76 in ²) PULL 3,81 cm ² (.59 in ²)
	15mm		
	20mm		

	Standard Threads	"EM" Option
"B"	M5X0,8	#10-32

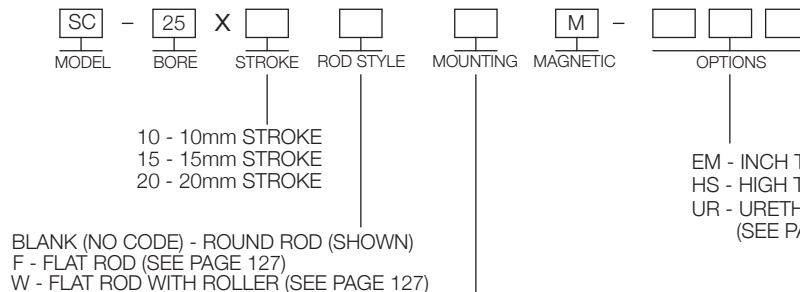
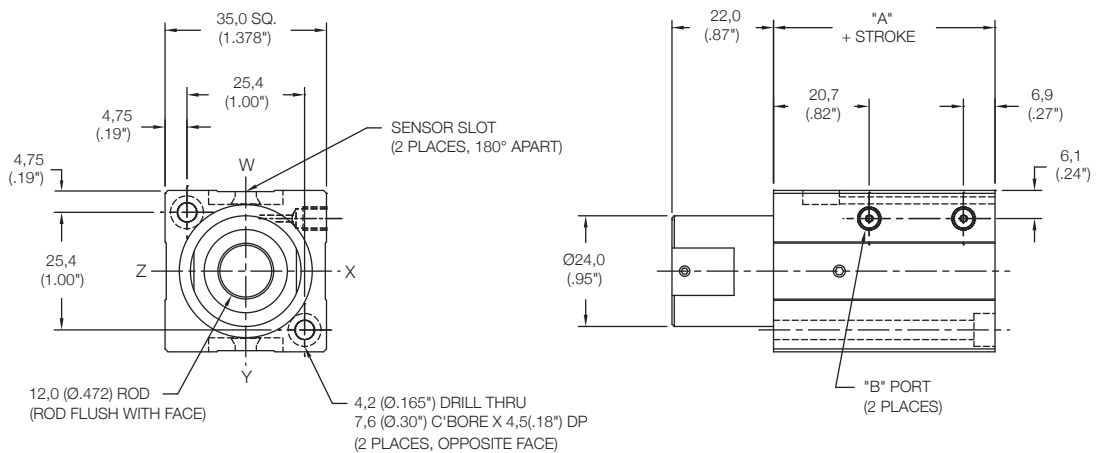

SENSORS SOLD SEPARATELY
SKS, SKP, SCS, SCP - SOLID STATE
LIMIT SENSORS
(SEE PAGE 88 FOR DETAILS)

MB - BOTH END MOUNTS
MF - FRONT MOUNT
MR - REAR MOUNT
MT - THRU MOUNT
FR - FLANGE ON REAR FACE (SEE PAGE 128)

Non Magnetic Side Mount Cylinder "MS"

MODEL	STANDARD STROKES	"A"	PISTON AREA
SC	10mm	38,0 (1.50")	PUSH 4,91 cm ² (0.76 in ²) PULL 3,81 cm ² (0.59 in ²)
	15mm		
	20mm		

	Standard Threads	"EM" Option
"B"	M5X0,8	#10-32
"C"	M5X0,8	#10-32

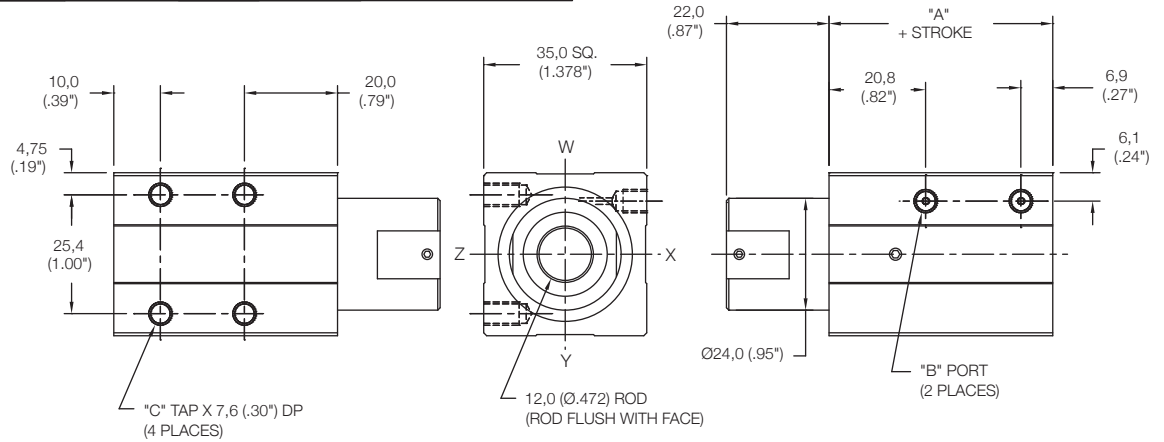

Magnetic Side Mount Cylinder "MS"

MODEL	STANDARD STROKES	"A"	PISTON AREA
SC	10mm	38,0 (1.50")	PUSH 4,91 cm ² (0.76 in ²) PULL 3,81 cm ² (0.59 in ²)
	15mm		
	20mm		

	Standard Threads	"EM" Option
"B"	M5X0,8	#10-32
"C"	M5X0,8	#10-32

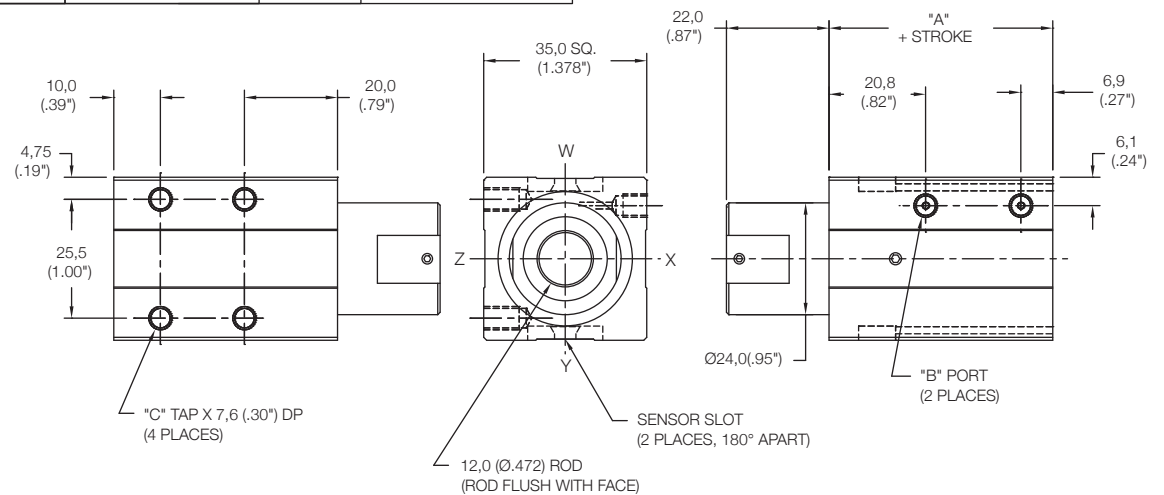

10 - 10mm STROKE
15 - 15mm STROKE
20 - 20mm STROKE

MS - SIDE THREADS
FS - SIDE FLANGES
(SEE PAGE 128)

EM - INCH THREADS & PORTS
HS - HIGH TEMP SEALS (SEE PAGE 97)
UR - URETHANE SHOCK PAD REAR
(SEE PAGE 97)

BLANK (NO CODE) - ROUND ROD (SHOWN)
F - FLAT ROD (SEE PAGE 127)
W - FLAT ROD WITH ROLLER (SEE PAGE 127)

BLANK (NO CODE) - STANDARD "NO MAGNET" PISTON
M - MAGNETIC PISTON AND SENSOR MOUNTING SLOTS

SENSORS SOLD SEPARATELY
SKS, SKP, SCS, SCP - SOLID STATE
LIMIT SENSORS
(SEE PAGE 88 FOR DETAILS)

Non Magnetic Front Mount Cylinder "MF"

MODEL	STANDARD STROKES	"A"	PISTON AREA
SC	10mm	44,0 (1.73")	PUSH 8,04 cm ² (1.25 in ²) PULL 4,91 cm ² (0.76 in ²)
	15mm		
	20mm		

	Standard Threads	"EM" Option
"B"	G 1/8 PORT	1/8-27
"C"	M6X1,0	1/4-20

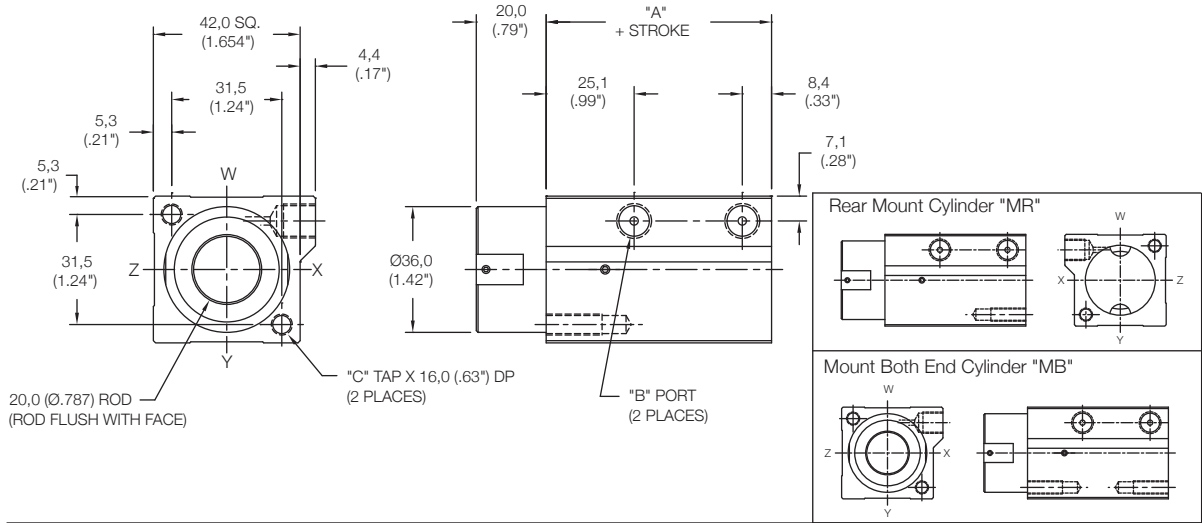

Non Magnetic Thru Mount Cylinder "MT"

MODEL	STANDARD STROKES	"A"	PISTON AREA
SC	10mm	44,0 (1.73")	PUSH 8,04 cm ² (1.25 in ²) PULL 4,91 cm ² (0.76 in ²)
	15mm		
	20mm		

	Standard Threads	"EM" Option
"B"	G 1/8 PORT	1/8-27

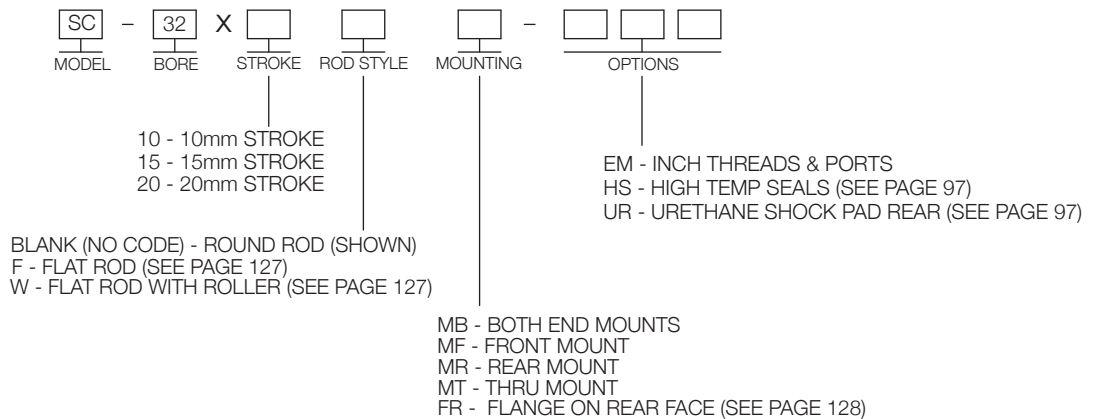
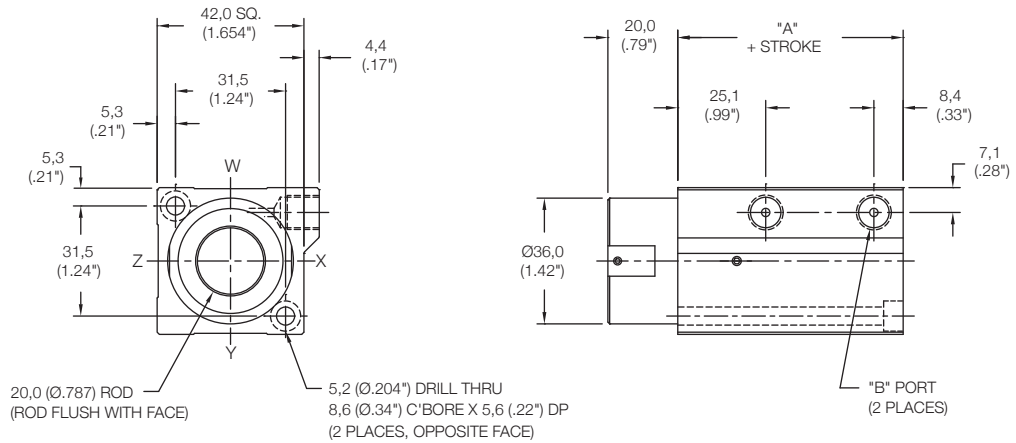

Non Magnetic Side Mount Cylinder "MS"

MODEL	STANDARD STROKES	"A"	PISTON AREA
SC	10mm	44,0 (1.73")	PUSH 8,04 cm ² (1.25 in ²) PULL 4,91 cm ² (0.76 in ²)
	15mm		
	20mm		

	Standard Threads	"EM" Option
"B"	G 1/8 PORT	1/8-27
"C"	M5X0,8	#10-32

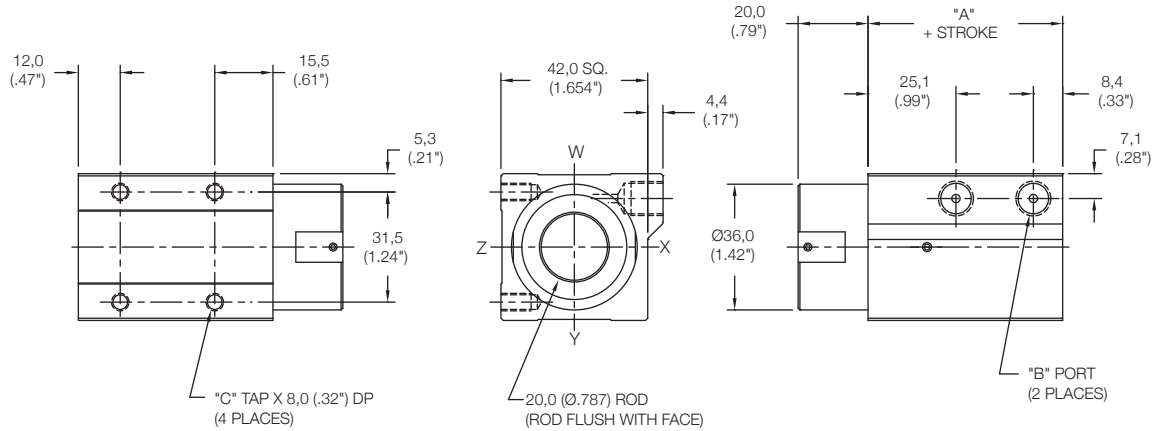

Magnetic Side Mount Cylinder "MS"

MODEL	STANDARD STROKES	"A"	PISTON AREA
SC	10mm	44,0 (1.73")	PUSH 8,04 cm ² (1.25 in ²) PULL 4,91 cm ² (0.76 in ²)
	15mm		
	20mm		

	Standard Threads	"EM" Option
"B"	G 1/8 PORT	1/8-27
"C"	M5X0,8	#10-32

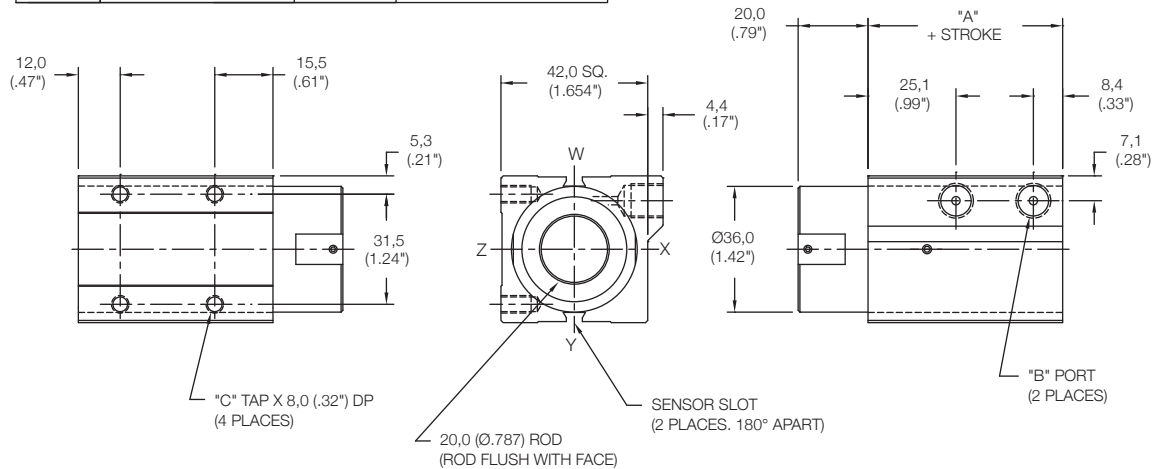

10 - 10mm STROKE
15 - 15mm STROKE
20 - 20mm STROKE

MS - SIDE THREADS
FS - SIDE FLANGES
(SEE PAGE 128)

EM - INCH THREADS & PORTS
HS - HIGH TEMP SEALS (SEE PAGE 97)
UR - URETHANE SHOCK PAD REAR
(SEE PAGE 97)

BLANK (NO CODE) - ROUND ROD (SHOWN)
F - FLAT ROD (SEE PAGE 127)
W - FLAT ROD WITH ROLLER (SEE PAGE 127)

BLANK (NO CODE) - STANDARD "NO MAGNET" PISTON
M - MAGNETIC PISTON AND SENSOR MOUNTING SLOTS

SENSORS SOLD SEPARATELY
SKS, SKP, SCS, SCP - SOLID STATE
LIMIT SENSORS
(SEE PAGE 88 FOR DETAILS)

Non Magnetic Front Mount Cylinder "MF"

MODEL	STANDARD STROKES	"A"	PISTON AREA
SC	20mm	47,0 (1.85")	PUSH 12,56 cm ² (1.95 in ²) PULL 9,42 cm ² (1.46 in ²)
	25mm		
	30mm		

	Standard Threads	"EM" Option
"B"	G 1/8 PORT	1/8-27
"C"	M6X1,0	1/4-20

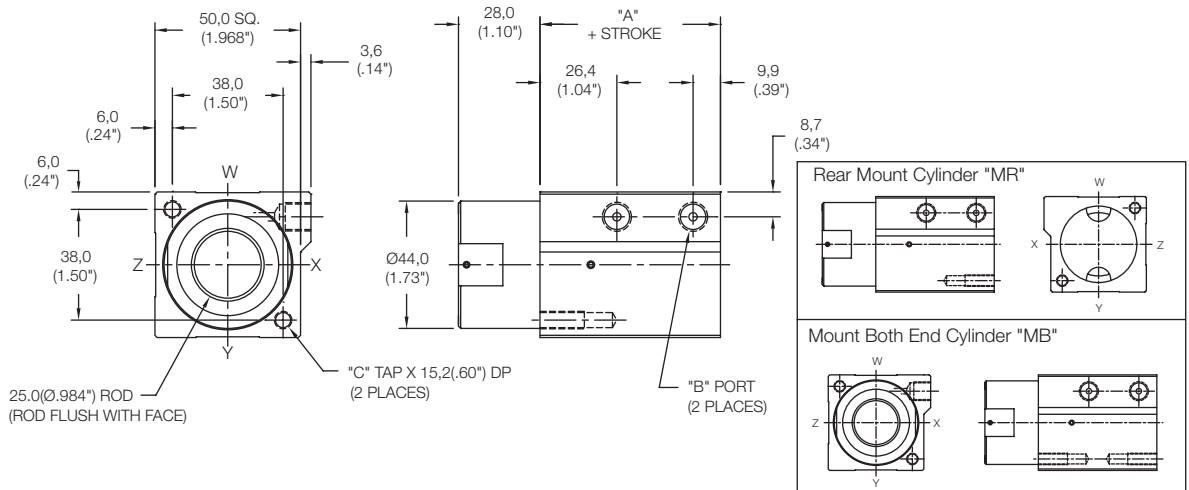

Non Magnetic Thru Mount Cylinder "MT"

MODEL	STANDARD STROKES	"A"	PISTON AREA
SC	20mm	47,0 (1.85")	PUSH 12,56 cm ² (1.95 in ²) PULL 9,42 cm ² (1.46 in ²)
	25mm		
	30mm		

	Standard Threads	"EM" Option
"B"	G 1/8 PORT	1/8-27

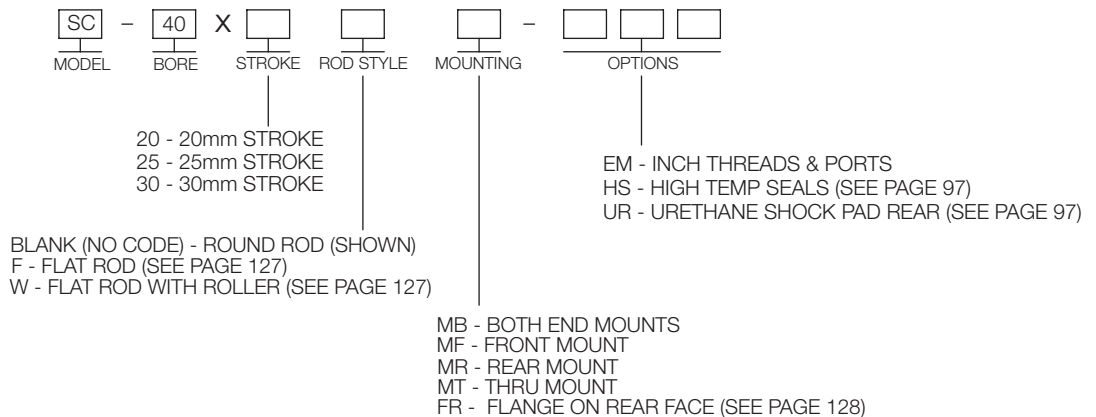
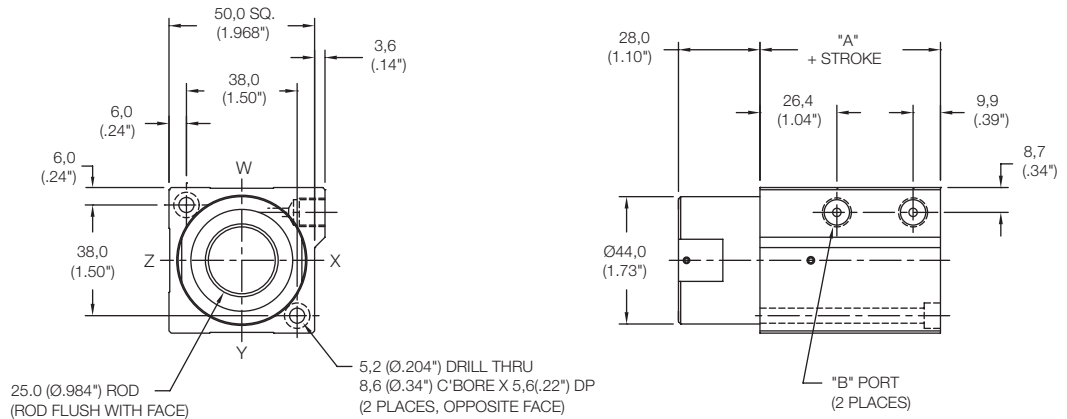

Magnetic Front Mount Cylinder "MF"

MODEL	STANDARD STROKES	"A"	PISTON AREA
SC	20mm	47,0 (1.85")	PUSH 12,56 cm ² (1.95 in ²) PULL 9,42 cm ² (1.46 in ²)
	25mm		
	30mm		

	Standard Threads	"EM" Option
"B"	G 1/8 PORT	1/8-27
"C"	M6X1,0	1/4-20

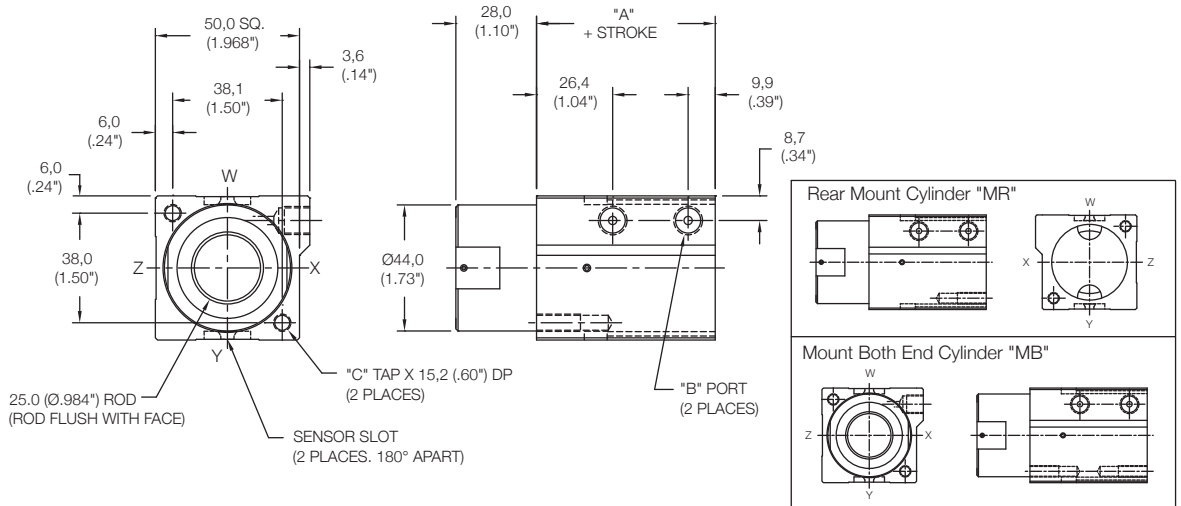

Magnetic Thru Mount Cylinder "MT"

MODEL	STANDARD STROKES	"A"	PISTON AREA
SC	20mm	47,0 (1.85")	PUSH 12,56 cm ² (1.95 in ²) PULL 9,42 cm ² (1.46 in ²)
	25mm		
	30mm		

	Standard Threads	"EM" Option
"B"	G 1/8 PORT	1/8-27

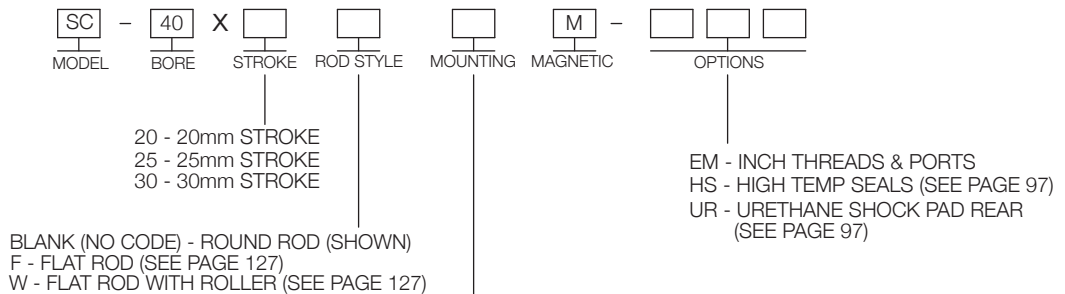
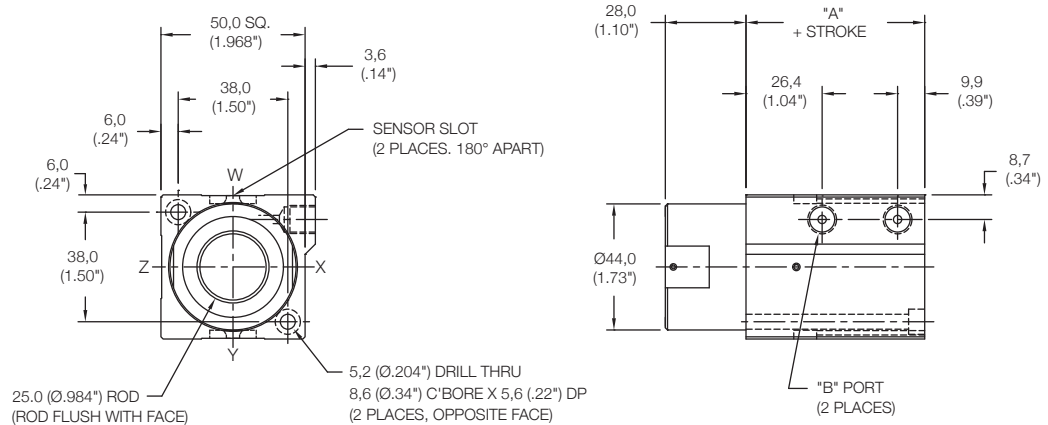

SENSORS SOLD SEPARATELY
SKS, SKP, SCS, SCP - SOLID STATE
LIMIT SENSORS
(SEE PAGE 88 FOR DETAILS)

MB - BOTH END MOUNTS
MF - FRONT MOUNT
MR - REAR MOUNT
MT - THRU MOUNT
FR - FLANGE ON REAR FACE (SEE PAGE 128)

Non Magnetic Side Mount Cylinder "MS"

MODEL	STANDARD STROKES	"A"	PISTON AREA
SC	20mm	49,5 (1.95")	PUSH 19,63 cm ² (3.04 in ²) PULL 14,72 cm ² (2.28 in ²)
	25mm		
	30mm		

	Standard Threads	"EM" Option
"B"	G 1/8 PORT	1/8-27
"C"	M8X1,25	5/16-18

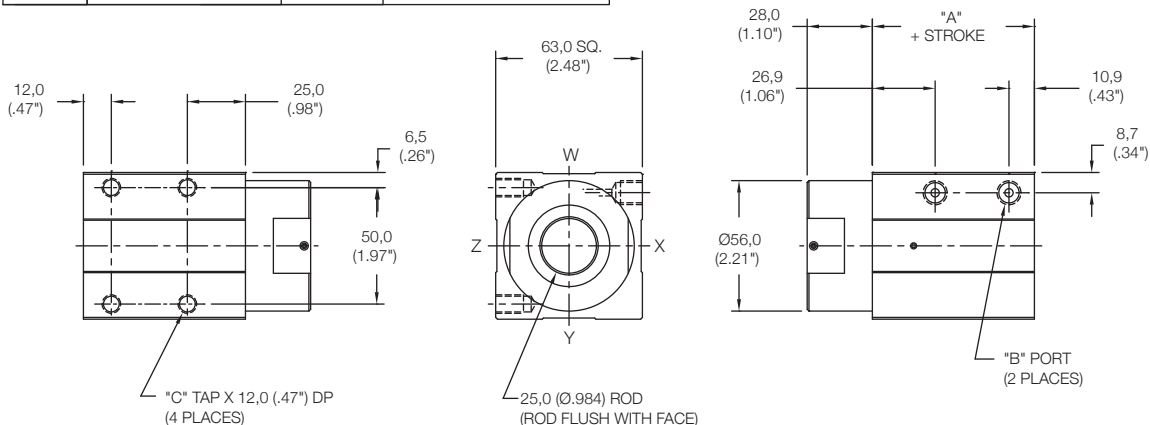

Magnetic Side Mount Cylinder "MS"

MODEL	STANDARD STROKES	"A"	PISTON AREA
SC	20mm	49,5 (1.95")	PUSH 19,63 cm ² (3.04 in ²) PULL 14,72 cm ² (2.28 in ²)
	25mm		
	30mm		

	Standard Threads	"EM" Option
"B"	G 1/8 PORT	1/8-27
"C"	M8X1,25	5/16-18

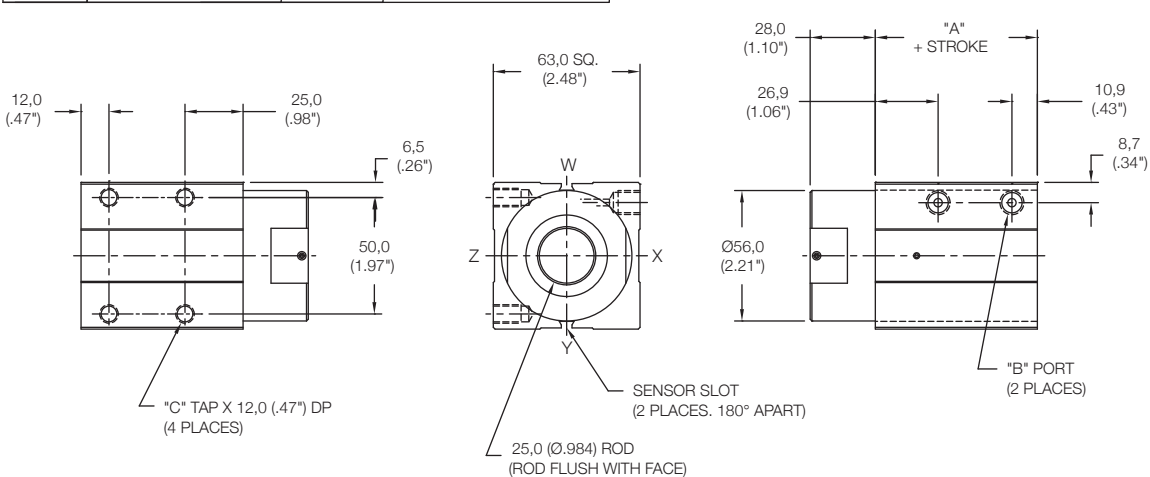

20 - 20mm STROKE
25 - 25mm STROKE
30 - 30mm STROKE

MS - SIDE THREADS
FS - SIDE FLANGES
(SEE PAGE 128)

EM - INCH THREADS & PORTS
HS - HIGH TEMP SEALS (SEE PAGE 97)
UR - URETHANE SHOCK PAD REAR
(SEE PAGE 97)

BLANK (NO CODE) - ROUND ROD (SHOWN)
F - FLAT ROD (SEE PAGE 127)
W - FLAT ROD WITH ROLLER (SEE PAGE 127)

BLANK (NO CODE) - STANDARD "NO MAGNET" PISTON
M - MAGNETIC PISTON AND SENSOR MOUNTING SLOTS

SENSORS SOLD SEPARATELY
SKS, SKP, SCS, SCP - SOLID STATE
LIMIT SENSORS
(SEE PAGE 88 FOR DETAILS)

Round Rod - Rod Code Blank (No Code)

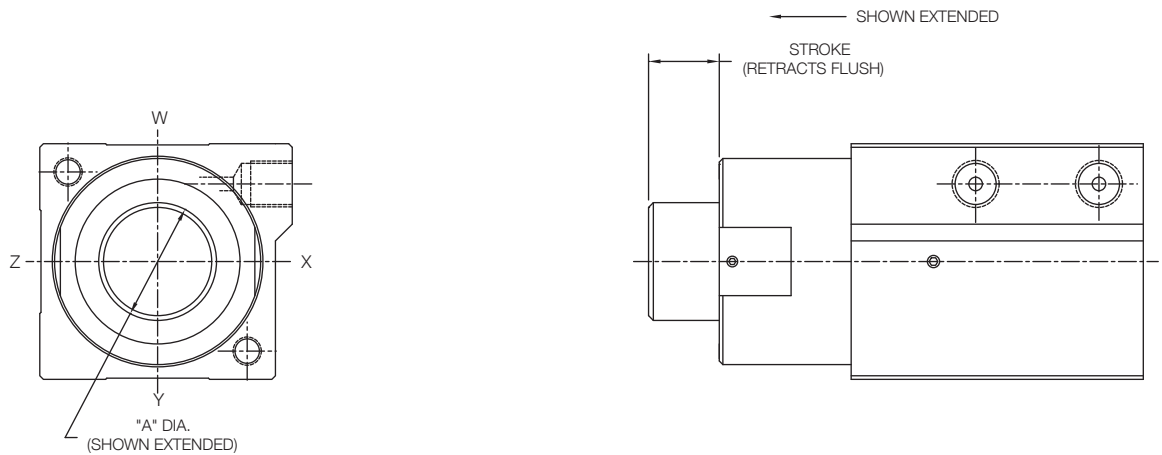

Flat Rod - Rod Code "F"

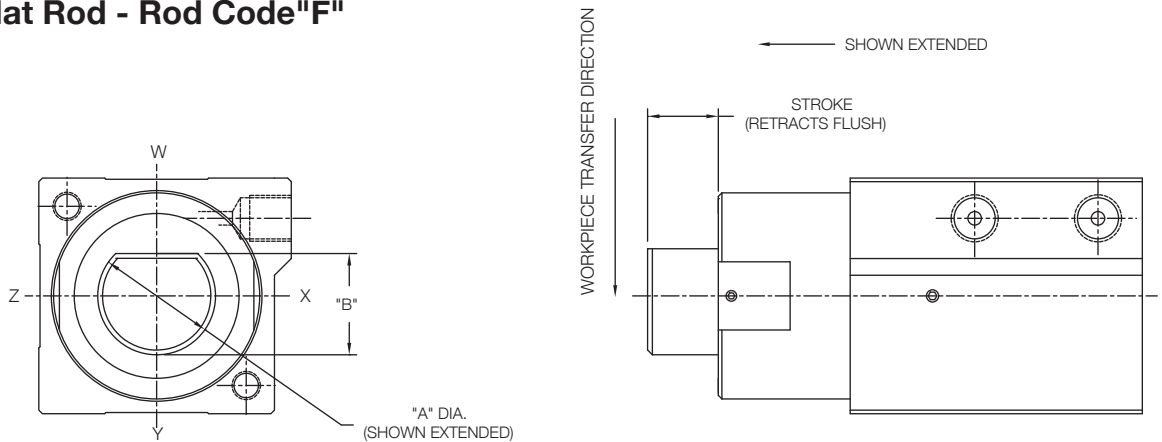

Standard orientation for flat is side "W". Flat can be reoriented to any position.

Flat Rod With Roller - Rod Code - "W"

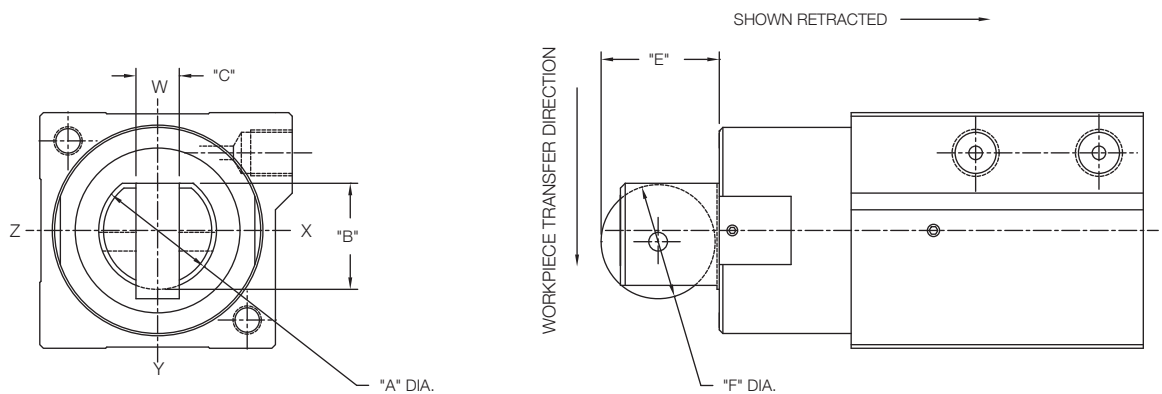

Standard orientation for flat is side "W". Flat can be reoriented to any position.

Bore	"A"	"B"	"C"	"D"	"E"	"F"
20	10,0(0.394")	8,0(0.315")	3,5 (.14")	6,35(0.25")	8,5 (0.33")	8,0 (0.32")
25	12,0(0.472")	10,0(0.394")	4,0(.16")	8,6(0.34")	11,0 (.43")	10,0 (0.39")
32	20,0(0.787")	18,0(0.709")	8,0 (.32")	17,0(0.67")	19,0 (.75")	18,0 (0.71")
40	25,0(0.984")	22,5(0.886")	9,0 (.35")	20,6(0.81")	25,0 (.98")	24,0 (0.95")
50	25,0(0.984")	22,5(0.886")	9,0 (.35")	20,6(0.81")	25,0 (.98")	24,0 (0.95")

- Rod shown extended on Round Rod and Flat Rod Styles
 - Roller material: Plastic

Rear Face Flange Mount - "FR"

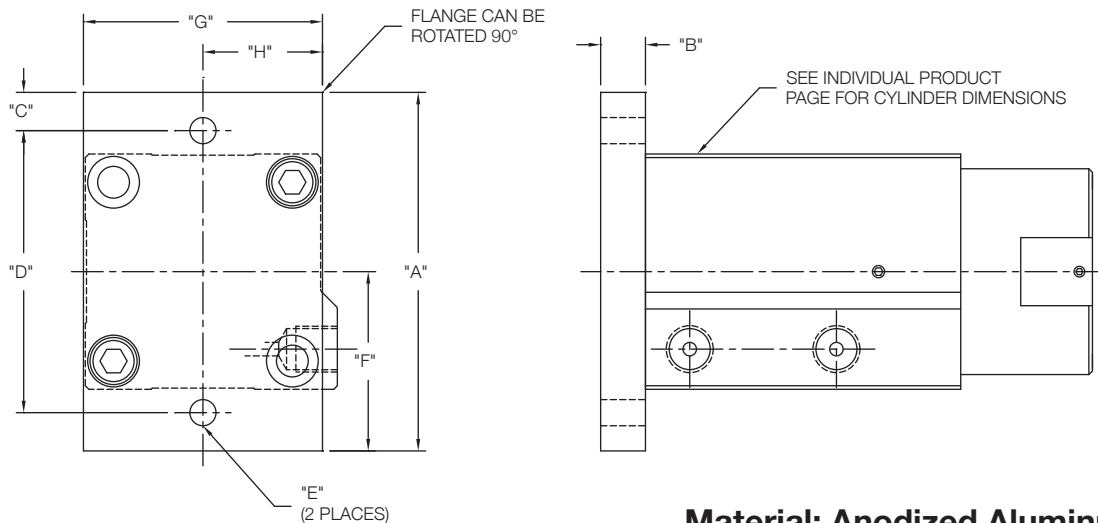

Material: Anodized Aluminum

Bore	"A"	"B"	"C"	"D"	"E"	"F"	"G"	"H"
20	50,8 (2.0")	9,5 (.38")	5,4 (.21")	40,0 (1.58")	4,5 (.18")	25,4 (1.0")	31,8 (1.25")	15,9 (.63")
25			3,9 (.15")	43,0 (1.69")				38,1 (1.50")
32	63,5 (2.5")	9,5 (.38")	5,75 (.23")	52,0 (2.05")	5,5 (.22")	31,8 (1.25")	44,5 (1.75")	22,25 (.88")
40	76,2 (3.0")			8,1 (.32")			60,0 (2.36")	
50	93,0 (3.66")	12,7 (.50")	7,5 (.30")	78,0 (3.07")	8,5 (.33")	46,5 (1.83")	63,5 (2.50")	31,8 (1.25")

Side Flange Mount - "FS"

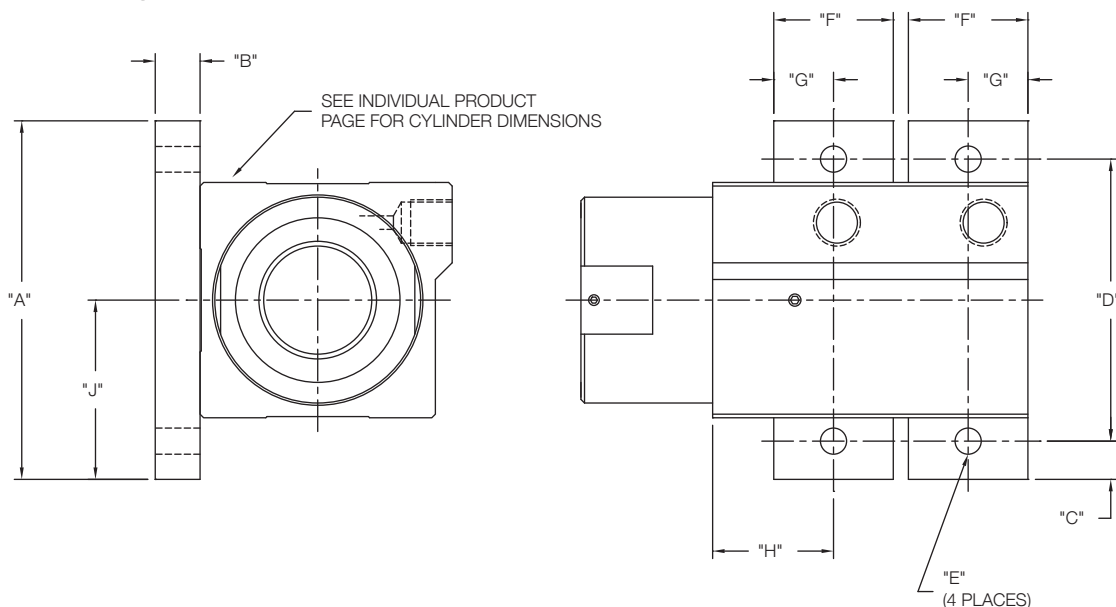

Material: Anodized Aluminum

Bore	"A"	"B"	"C"	"D"	"E"	"F"	"G"	"H"	"J"
20	50,8 (2.00")	9,5 (.38")	5,4 (.21")	40 (1.58")	4,5 (.18")	19 (.75")	9,5 (.38")	20,0 (.79")	25,4 (1.0")
25				3,9 (.15")				43 (1.69")	
32	63,5 (2.50")	9,5 (.38")	5,75 (.23")	52 (2.05")	5,5 (.22")	25,4 (1.00")	12,7 (.50")	16,25 (.64")	31,8 (1.25")
40	76,2 (3.00")			8,1 (.32")				60 (2.36")	
50	93 (3.66")	12,7 (.50")	7,5 (.30")	78 (3.07")	8,5 (.33")			25,75 (1.01")	46,5 (1.83")

L15 SERIES

HYDRAULIC CYLINDERS

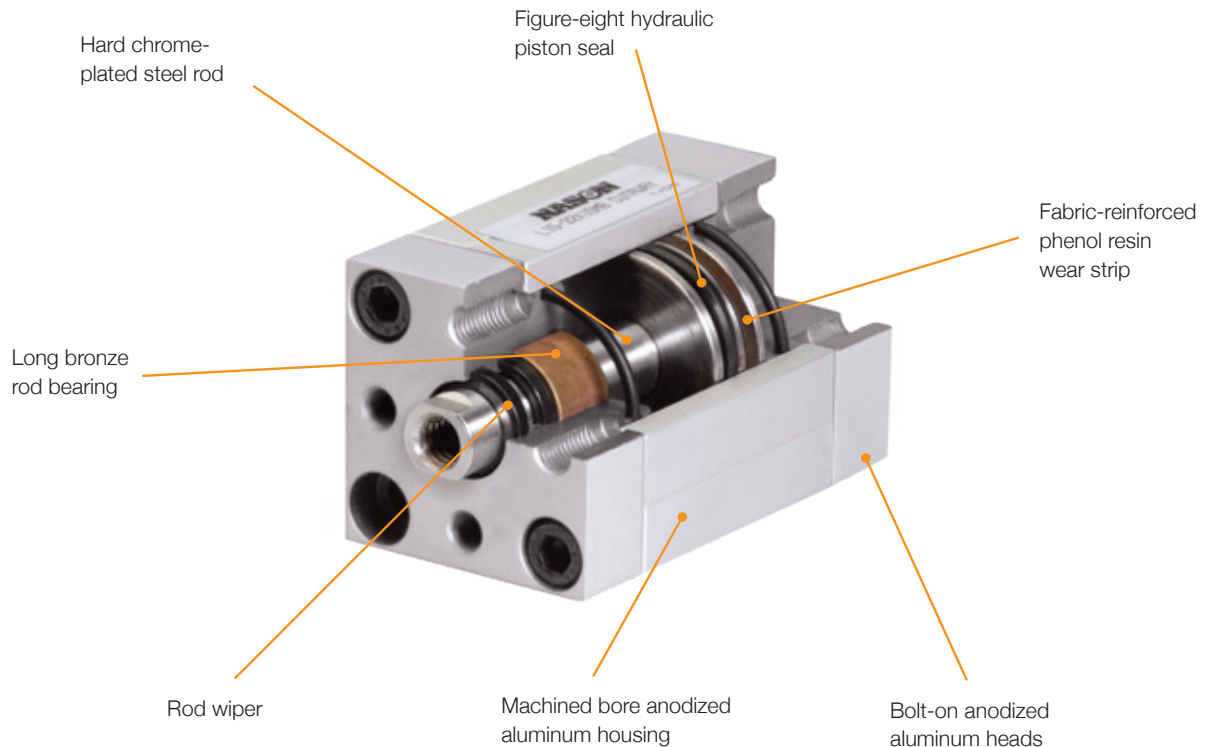

Common Features

Nason's L15 series hydraulic actuators were designed to be compact, low friction, long lasting devices for today's demanding design requirements. They are offered in single and double rod configurations with inch or metric mounting and ports.

Low Breakaway and Running Friction / Long Life

Designed for low startup and running friction, the L15 series contains low friction nitrile seals, and the cylinders are lubricated at the factory with PTFE impregnated grease. Precision-machined components and self-lubricating bearings ensure long life and continued low friction operation.

Compact Size

Nason L15 cylinders were designed with today's automation equipment in mind. They offer more

power in a smaller package than comparable 1500 PSI hydraulic cylinders.

Rugged Construction

The L15 series incorporates thick-walled, anodized aluminum housings and caps. Rods are chrome-plated 1045/1050 steel riding in self-lubricating bronze bearings. Hardened fasteners are used for assembly. Steel pistons with wear rings and rod wipers are standard on all models.

Versatile Design

The L15 series cylinders are metric in design (bore and rod sizes). They are offered in inch or metric mounting and porting. Due to their 100% machined design, they are easily customized by Nason.

Rebuildable

All L15 series cylinders are field-rebuildable.

How to Order

Example:

Part Number: L15-32X25MS-EMRVRS

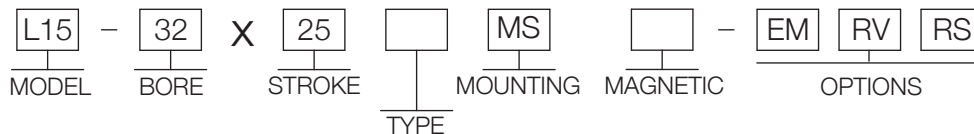

MODEL
L15 - 1500 PSI Hydraulic Cylinder

MOUNTING
MF - Threads on Front Face (Rod End)
MR - Threads on Rear Face (Opposite Rod)
MB - Threads on Both Faces
MS - Threads on Side of Cylinder Body

BORE
20 - 20mm (.79")
25 - 25mm (.98")
32 - 32mm (1.26")
40 - 40mm (1.58")
50 - 50mm (1.97")

MAGNETIC
BLANK (No Code) - Standard No Magnet
M - Magnetic Piston and Sensor Mounting

STROKE
15 - 15mm (.59")
25 - 25mm (.98")
40 - 40mm (1.58")
50 - 50mm (1.97")
65 - 65mm (2.56")
75 - 75mm (2.95")

OPTIONS
EM - InchThreads (Mounting and Ports) (See product pages for sizes)
RS - Male Stud for Rod End (Length - 2 x Thread Diameter)
RF - 5mm (.197") Rod Extension
RT - 10mm (.394") Rod Extension
RV - 25mm (.984") Rod Extension

TYPE
BLANK (No Code) - Double Acting, Single Rod
D - Double Acting, Double Rod

Operating Media: Mineral oil, water polyglycol solutions, water-in-oil emulsions

Maximum Operating Pressure: 103 Bar (1500 PSI)
50mm Bore Magnetic Piston—69 Bar (1,000 PSI)

Operating Temperature: -10°C to 70°C (0°F to 158°F)

Packing: Buna N

Lubrication: PTFE impregnated grease

Stroke Tolerance: +0,75mm/-0mm
(+0.03"/-0")

Piston Area Chart

Bore	Push (Rod Extend)	Pull (Rod Retract)
20	3,14 cm ² (.48 in ²)	2,64 cm ² (.40 in ²)
25	4,91 cm ² (.76 in ²)	4,12 cm ² (.64 in ²)
32	8,04 cm ² (1.25 in ²)	6,91 cm ² (1.07 in ²)
40	12,56 cm ² (1.95 in ²)	10,55 cm ² (1.64 in ²)
50	19,63 cm ² (3.04 in ²)	16,49 cm ² (2.56 in ²)

Cylinder Output Force Formula

Piston Area x Pressure = Output Force
Piston Area (in ²) x Pressure (PSI) = lbf (Pounds Force)
Piston Area (cm ²) x Pressure (kg/cm ²) = kgf (Kilograms Force)
Piston Area (cm ²) x Pressure (kg/cm ²) x 9.8 = Newtons
Piston Area (cm ²) x Pressure (Bar) x 10 = Newtons
Piston Area (cm ²) x Pressure (Bar) x 10 = Newtons
Piston Area (cm ²) x Pressure (Bar) x 1.02 = kgf (Kilograms Force)

Non Magnetic Front Mount Cylinder "MF"

MODEL	TYPE	STANDARD STROKES	"A"	PISTON AREA
L15	_D	15mm	47,0 (1.85")	PUSH 3,14 cm ² (0.48 in ²) PULL 2,64 cm ² (0.40 in ²)
		25mm		
		40mm		
		50mm		
		65mm		
		75mm		

	Standard Threads	"EM" Option
"B"	R 1/8 (1/8-28 BSPT)	1/8-27
"C"	M5X0,8	#10-32
"D"	M4X0,7	#8-32

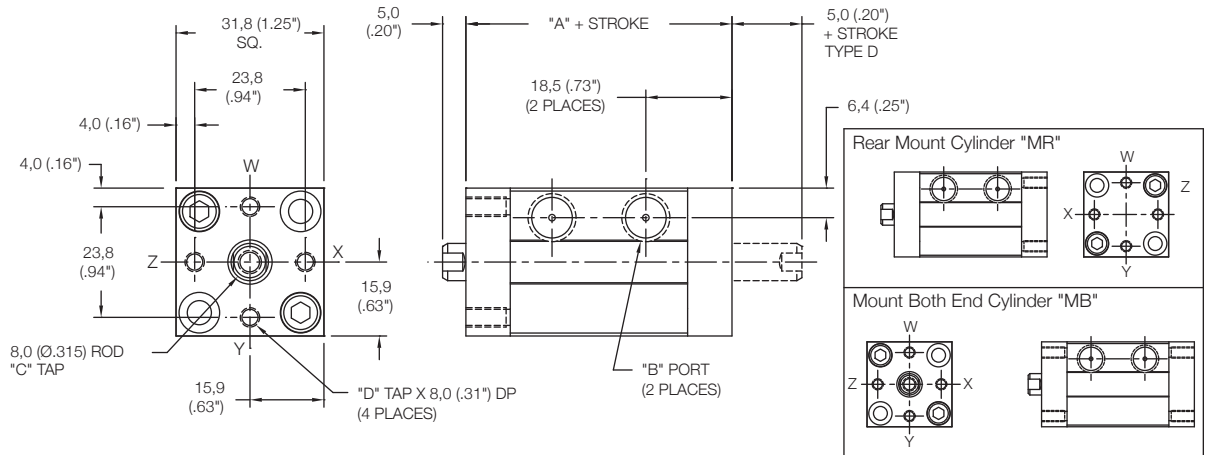

Non Magnetic Side Mount Cylinder "MS"

MODEL	TYPE	STANDARD STROKES	"A"	PISTON AREA
L15	_D	15mm	47,0 (1.85")	PUSH 3,14 cm ² (0.48 in ²) PULL 2,64 cm ² (0.40 in ²)
		25mm		
		40mm		
		50mm		
		65mm		
		75mm		

	Standard Threads	"EM" Option
"B"	R 1/8 (1/8-28 BSPT)	1/8-27
"C"	M5X0,8	#10-32
"D"	M4X0,7	#8-32

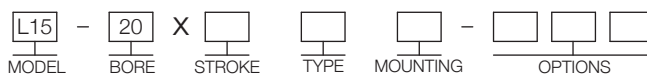
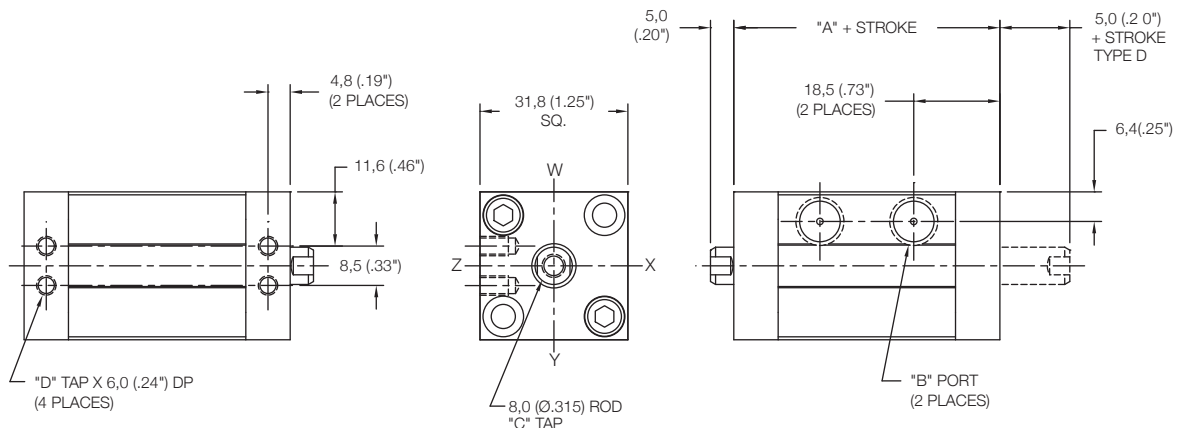

15mm - 75mm STROKE
(SEE STROKE RANGE)

BLANK - NO CODE
D - DOUBLE ROD

MB - BOTH END MOUNT
MF - FRONT MOUNT
MR - REAR MOUNT
MS - SIDE MOUNT

EM - INCH THREADS & PORT OPTIONS:
RS - MALE STUD FOR ROD END
(SEE PAGE 96 FOR DETAILS)
RF, RH, RN, RT, RV, RY - ROD EXTENSIONS
(SEE PAGE 96 FOR DETAILS)

Non Magnetic Front Mount Cylinder "MF"

MODEL	TYPE	STANDARD STROKES	"A"	PISTON AREA
L15	...D	15mm	53,0 (2.09")	PUSH 4,91 cm ² (0.76 in ²)
		25mm		
		40mm		
		50mm		PULL 4,12 cm ² (0.64 in ²)
		65mm		
		75mm		

	Standard Threads	"EM" Option
"B"	R 1/8 (1/8-28 BSPT)	1/8-27
"C"	M6X1,0	1/4-20
"D"	M5X0,8	#10-32

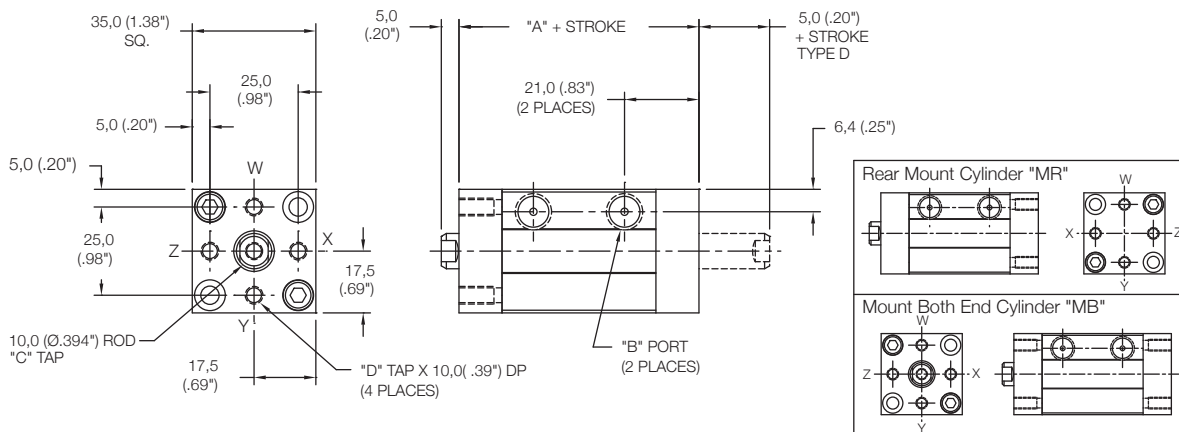

Non Magnetic Side Mount Cylinder "MS"

MODEL	TYPE	STANDARD STROKES	"A"	PISTON AREA
L15	...D	15mm	53,0 (2.09")	PUSH 4,91 cm ² (0.76 in ²)
		25mm		
		40mm		
		50mm		PULL 4,12 cm ² (0.64 in ²)
		65mm		
		75mm		

	Standard Threads	"EM" Option
"B"	R 1/8 (1/8-28 BSPT)	1/8-27
"C"	M6X1,0	1/4-20
"D"	M5X0,8	#10-32

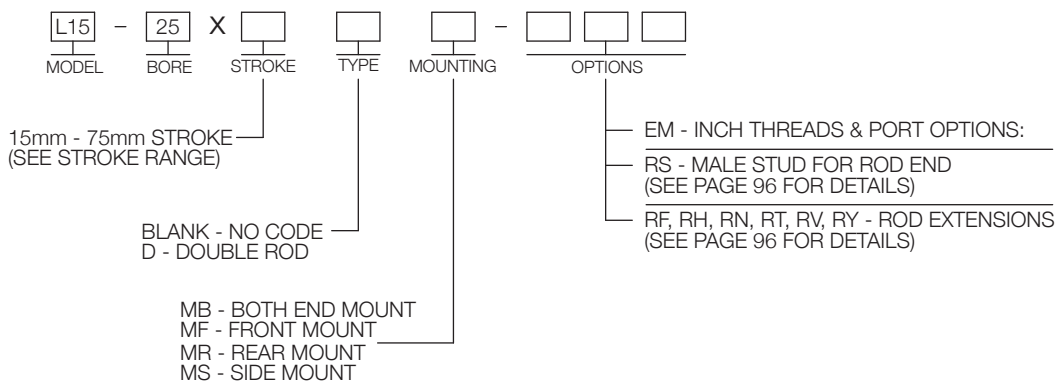
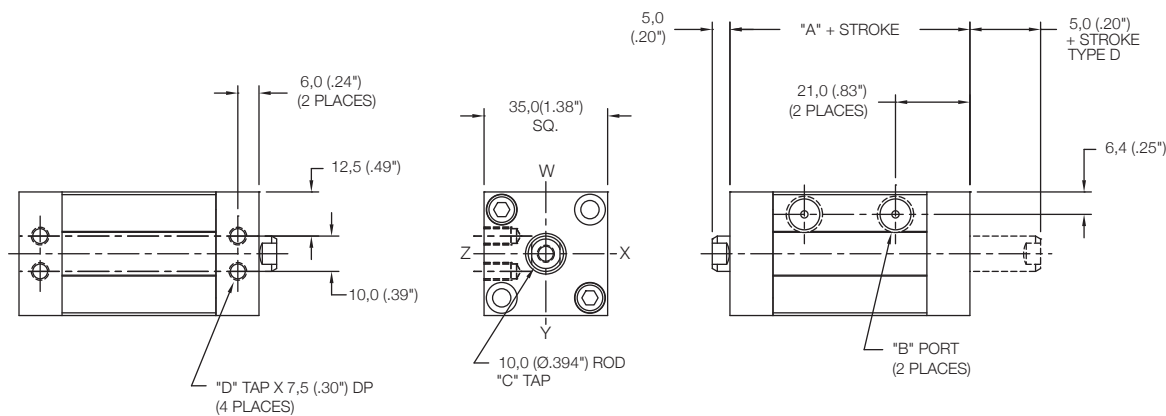

Magnetic Front Mount Cylinder "MF"

MODEL	TYPE	STANDARD STROKES	"A"	PISTON AREA
L15	_,D	15mm	68,0 (2.68")	PUSH 4,91 cm ² (0.76 in ²)
		25mm		
		40mm		PULL 4,12 cm ² (0.64 in ²)
		50mm		
		65mm		
75mm				

	Standard Threads	"EM" Option
"B"	R 1/8 (1/8-28 BSPT)	1/8-27
"C"	M6X1,0	1/4-20
"D"	M5X0,8	#10-32

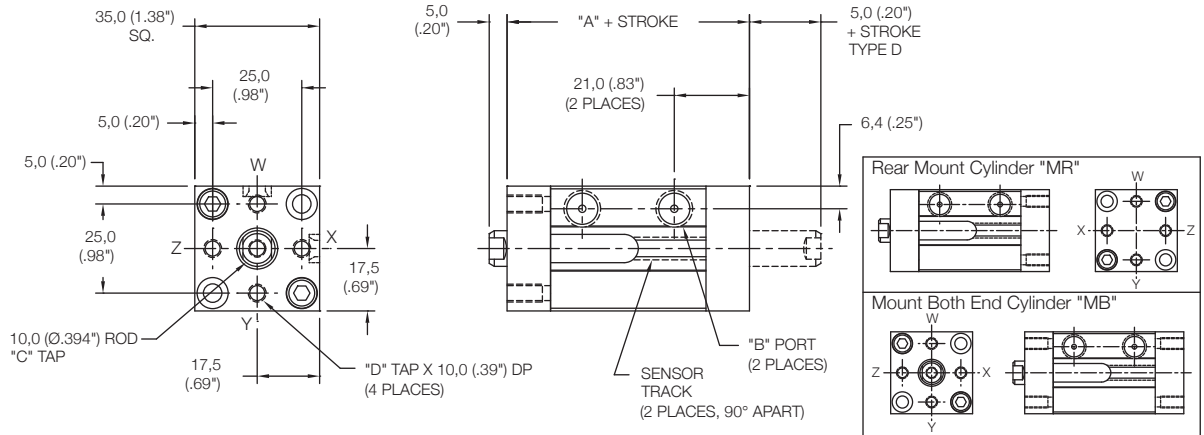

Magnetic Side Mount Cylinder "MS"

MODEL	TYPE	STANDARD STROKES	"A"	PISTON AREA
L15	_,D	15mm	68,0 (2.68")	PUSH 4,91 cm ² (0.76 in ²)
		25mm		
		40mm		PULL 4,12 cm ² (0.64 in ²)
		50mm		
		65mm		
75mm				

	Standard Threads	"EM" Option
"B"	R 1/8 (1/8-28 BSPT)	1/8-27
"C"	M6X1,0	1/4-20
"D"	M5X0,8	#10-32

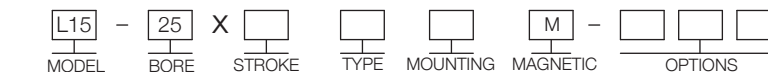
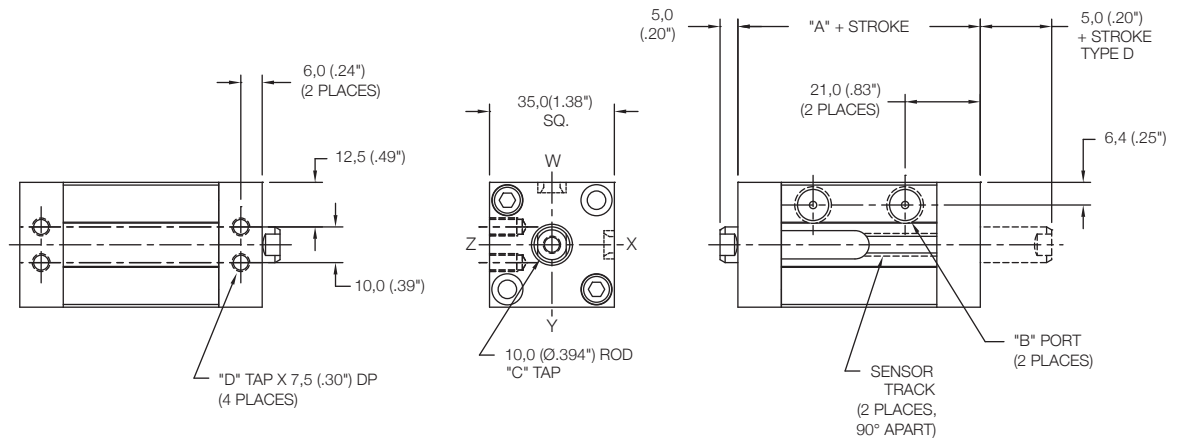

15mm - 75mm STROKE
(SEE STROKE RANGE)

BLANK - NO CODE
D - DOUBLE ROD

MB - BOTH END MOUNT
MF - FRONT MOUNT
MR - REAR MOUNT
MS - SIDE MOUNT

EM - INCH THREADS & PORT OPTIONS:
RS - MALE STUD FOR ROD END
(SEE PAGE 96 FOR DETAILS)
RF, RH, RN, RT, RV, RY - ROD EXTENSIONS
(SEE PAGE 96 FOR DETAILS)

SENSORS SOLD SEPARATELY
SKS, SKP, SCS, SCP - SOLID STATE
LIMIT SENSORS
(SEE PAGE 88 FOR DETAILS)

Non Magnetic Front Mount Cylinder "MF"

MODEL	TYPE	STANDARD STROKES	"A"	PISTON AREA
L15	_D	15mm	60,0 (2.36")	PUSH 8,04 cm ² (1.25 in ²) PULL 6,91 cm ² (1.07 in ²)
		25mm		
		40mm		
		50mm		
		65mm		
75mm				

	Standard Threads	"EM" Option
"B"	R 1/8 (1/8-28 BSPT)	1/8-27
"C"	M8X1,25	5/16-18
"D"	M6X1,0	1/4-20

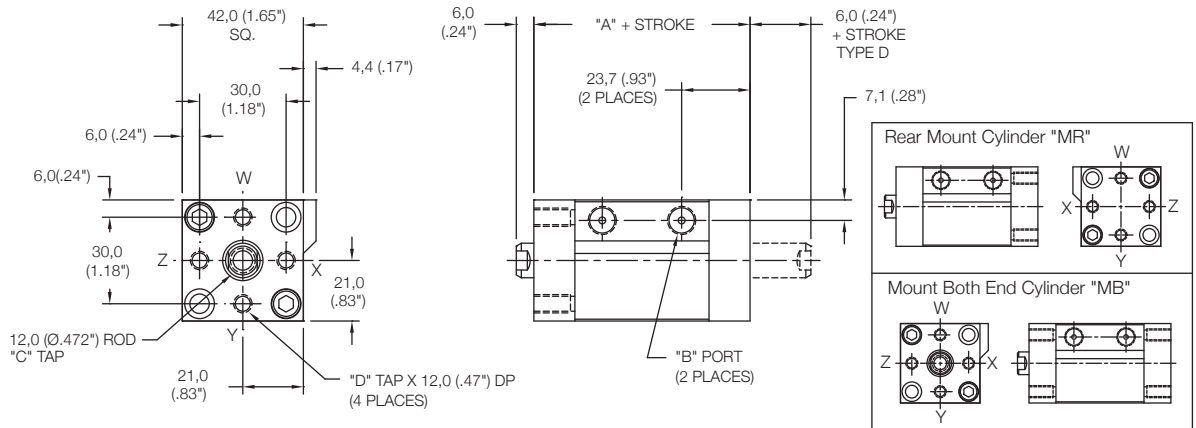

Non Magnetic Side Mount Cylinder "MS"

MODEL	TYPE	STANDARD STROKES	"A"	PISTON AREA
L15	_D	15mm	60,0 (2.36")	PUSH 8,04 cm ² (1.25 in ²) PULL 6,91 cm ² (1.07 in ²)
		25mm		
		40mm		
		50mm		
		65mm		
75mm				

	Standard Threads	"EM" Option
"B"	R 1/8 (1/8-28 BSPT)	1/8-27
"C"	M8X1,25	5/16-18
"D"	M6X1,0	1/4-20

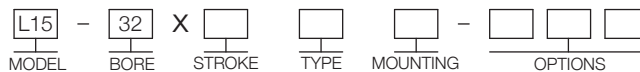
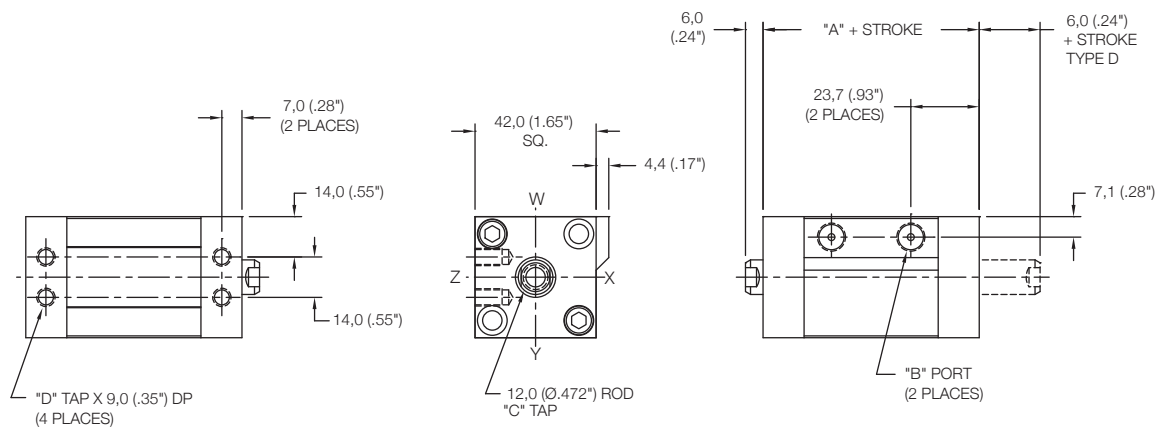

15mm - 75mm STROKE
(SEE STROKE RANGE)

BLANK - NO CODE
D - DOUBLE ROD

MB - BOTH END MOUNT
MF - FRONT MOUNT
MR - REAR MOUNT
MS - SIDE MOUNT

EM - INCH THREADS & PORT OPTIONS:

RS - MALE STUD FOR ROD END
(SEE PAGE 96 FOR DETAILS)

RF, RH, RN, RT, RV, RY - ROD EXTENSIONS
(SEE PAGE 96 FOR DETAILS)

Magnetic Front Mount Cylinder "MF"

MODEL	TYPE	STANDARD STROKES	"A"	PISTON AREA
L15	_,D	15mm - 75mm	75,0 (2.95")	PUSH 8,04 cm ² (1.25 in ²) PULL 6,91 cm ² (1.07 in ²)

	Standard Threads	"EM" Option
"B"	R 1/8 (1/8-28 BSPT)	1/8-27
"C"	M8X1,25	5/16-18
"D"	M6X1,0	1/4-20

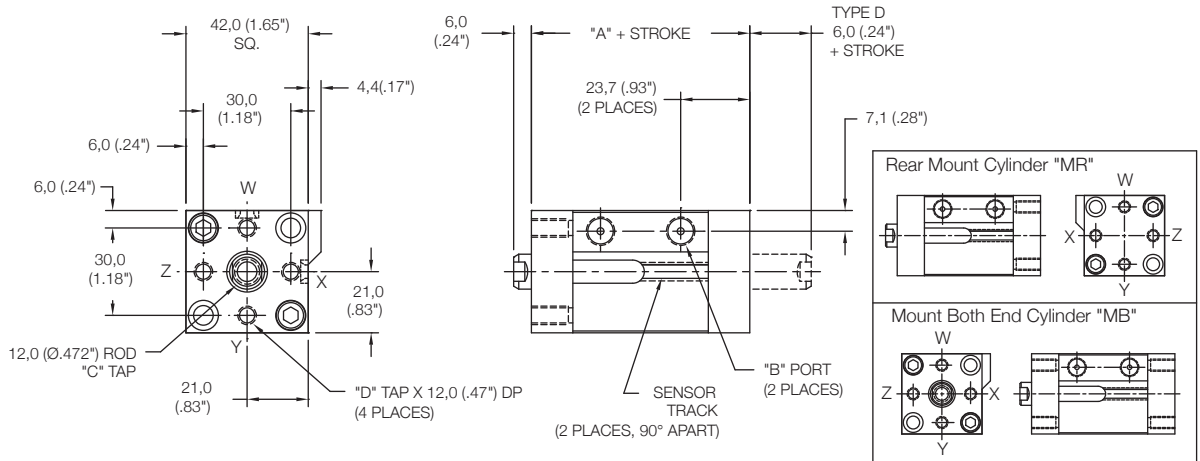

Magnetic Side Mount Cylinder "MS"

MODEL	TYPE	STANDARD STROKES	"A"	PISTON AREA
L15	_,D	15mm - 75mm	75,0 (2.95")	PUSH 8,04 cm ² (1.25 in ²) PULL 6,91 cm ² (1.07 in ²)

	Standard Threads	"EM" Option
"B"	R 1/8 (1/8-28 BSPT)	1/8-27
"C"	M8X1,25	5/16-18
"D"	M6X1,0	1/4-20

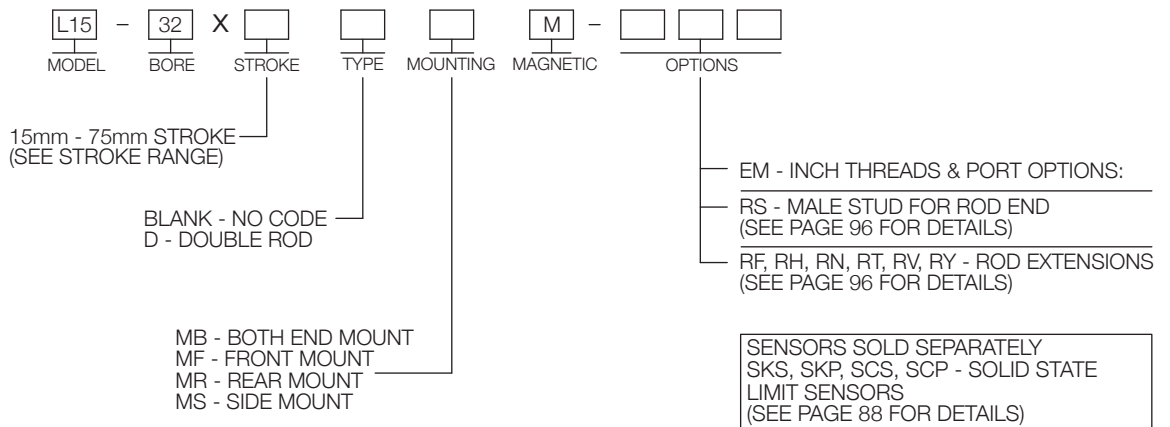
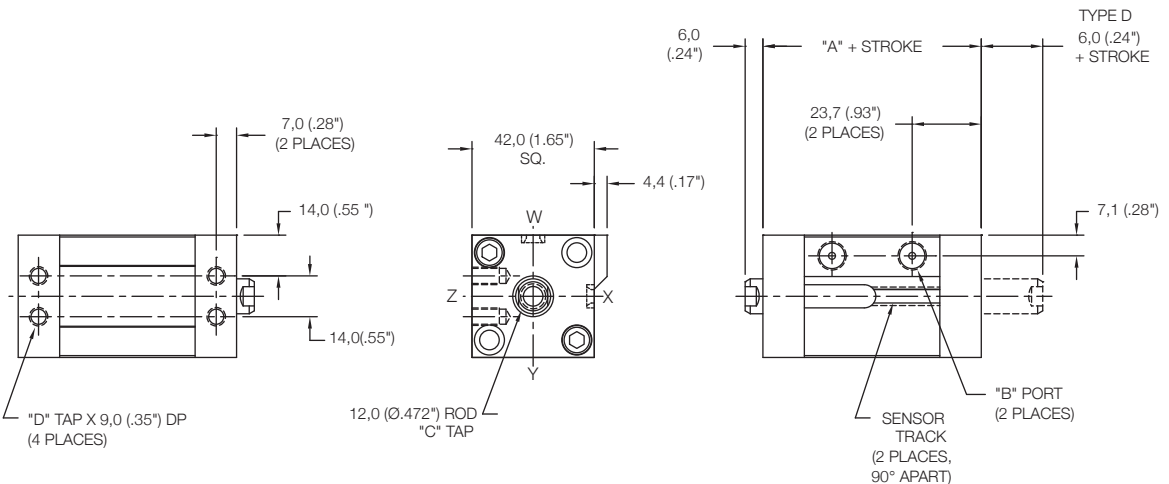

Non Magnetic Front Mount Cylinder "MF"

MODEL	TYPE	STANDARD STROKES	"A"	PISTON AREA
L15	..D	15mm	76,5 (3.01")	PUSH 12,56 cm ² (1.95 in ²)
		25mm		
		40mm		
		50mm		PULL 10,55 cm ² (1.64 in ²)
		65mm		
		75mm		

	Standard Threads	"EM" Option
"B"	R 1/8 (1/8-28 BSPT)	1/8-27
"C"	M10X1,5	3/8-24
"D"	M6X1,0	1/4-20

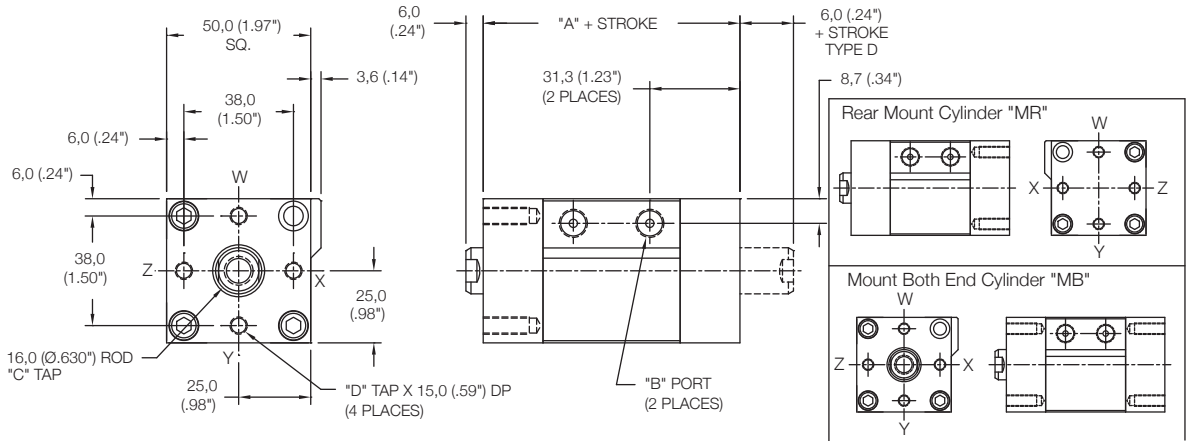

Non Magnetic Side Mount Cylinder "MS"

MODEL	TYPE	STANDARD STROKES	"A"	PISTON AREA
L15	..D	15mm	76,5 (3.01")	PUSH 12,56 cm ² (1.95 in ²)
		25mm		
		40mm		
		50mm		PULL 10,55 cm ² (1.64 in ²)
		65mm		
		75mm		

	Standard Threads	"EM" Option
"B"	R 1/8 (1/8-28 BSPT)	1/8-27
"C"	M10X1,5	3/8-24
"D"	M8X1,25	5/16-18

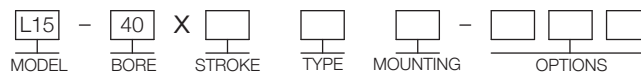
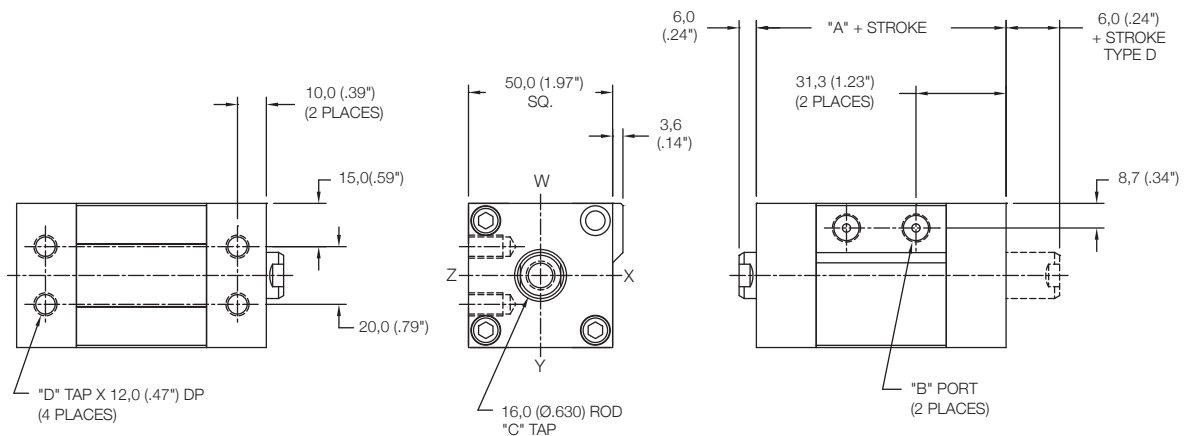

15mm - 75mm STROKE
(SEE STROKE RANGE)

BLANK - NO CODE
D - DOUBLE ROD

MB - BOTH END MOUNT
MF - FRONT MOUNT
MR - REAR MOUNT
MS - SIDE MOUNT

EM - INCH THREADS & PORT OPTIONS:

RS - MALE STUD FOR ROD END
(SEE PAGE 96 FOR DETAILS)

RF, RH, RN, RT, RV, RY - ROD EXTENSIONS
(SEE PAGE 96 FOR DETAILS)

Magnetic Front Mount Cylinder "MF"

MODEL	TYPE	STANDARD STROKES	"A"	PISTON AREA
L15	_D	15mm	91,5 (3.60")	PUSH 12,56 cm ² (1.95 in ²) PULL 10,55 cm ² (1.64 in ²)
		25mm		
		40mm		
		50mm		
		65mm		
		75mm		

	Standard Threads	"EM" Option
"B"	R 1/8 (1/8-28 BSPT)	1/8-27
"C"	M10X1,5	3/8-24
"D"	M6X1,0	1/4-20

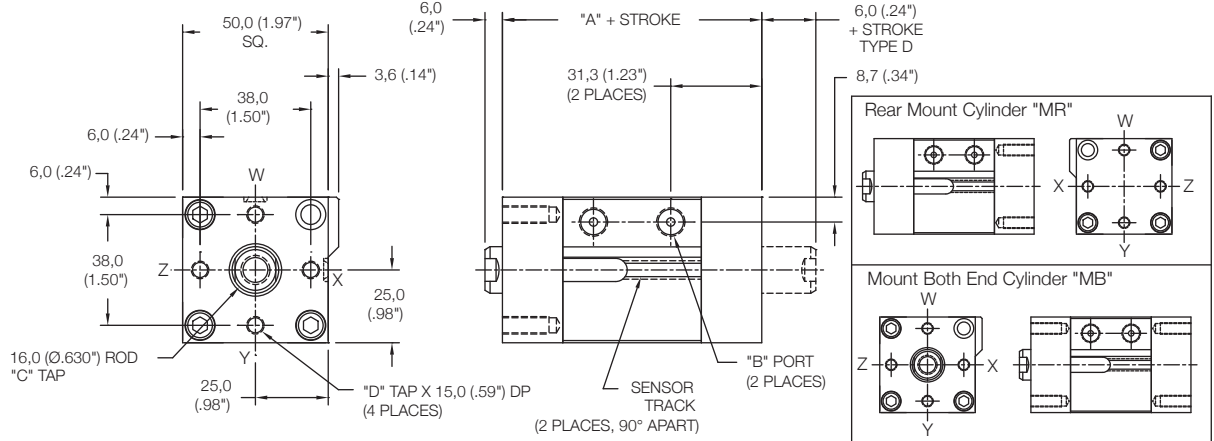

Magnetic Side Mount Cylinder "MS"

MODEL	TYPE	STANDARD STROKES	"A"	PISTON AREA
L15	_D	15mm	91,5 (3.60")	PUSH 12,56 cm ² (1.95 in ²) PULL 10,55 cm ² (1.64 in ²)
		25mm		
		40mm		
		50mm		
		65mm		
		75mm		

	Standard Threads	"EM" Option
"B"	R 1/8 (1/8-28 BSPT)	1/8-27
"C"	M10X1,5	3/8-24
"D"	M8X1,25	5/16-18

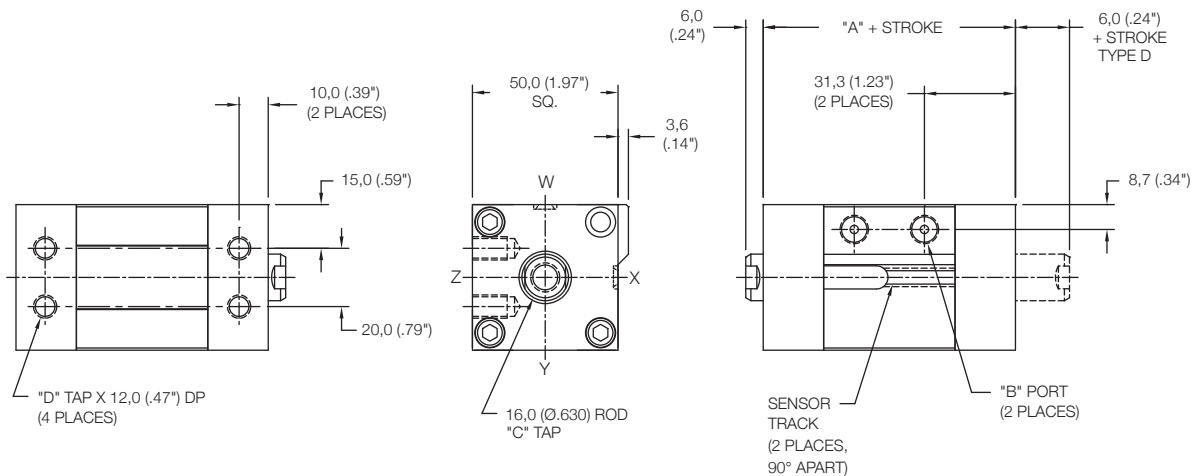

15mm - 75mm STROKE
(SEE STROKE RANGE)

BLANK - NO CODE
D - DOUBLE ROD

MB - BOTH END MOUNT
MF - FRONT MOUNT
MR - REAR MOUNT
MS - SIDE MOUNT

EM - INCH THREADS & PORT OPTIONS:

RS - MALE STUD FOR ROD END
(SEE PAGE 96 FOR DETAILS)

RF, RH, RN, RT, RV, RY - ROD EXTENSIONS
(SEE PAGE 96 FOR DETAILS)

SENSORS SOLD SEPARATELY
SKS, SKP, SCS, SCP - SOLID STATE
LIMIT SENSORS
(SEE PAGE 88 FOR DETAILS)

Non Magnetic Front Mount Cylinder "MF"

MODEL	TYPE	STANDARD STROKES	"A"	PISTON AREA
L15	_D	15mm	80,0 (3.15")	PUSH 19,63 cm ² (3.04 in ²)
		25mm		
		40mm		PULL 17,62 cm ² (2.73 in ²)
		50mm		
		65mm		
75mm				

	Standard Threads	"EM" Option
"B"	R 1/8 (1/8-28 BSPT)	1/8-27
"C"	M12X1,75	1/2-13
"D"	M8X1,25	5/16-18

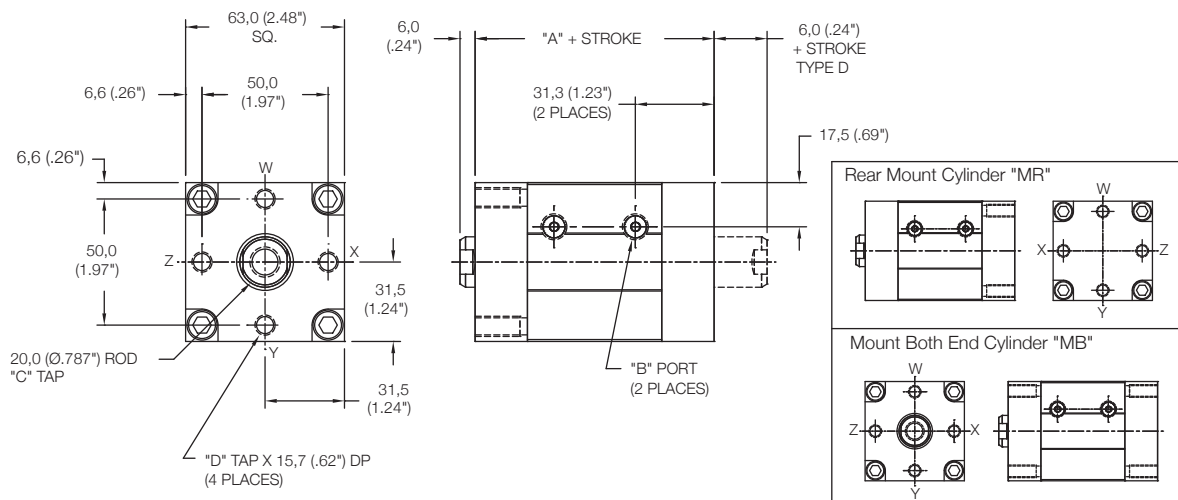

Non Magnetic Side Mount Cylinder "MS"

MODEL	TYPE	STANDARD STROKES	"A"	PISTON AREA
L15	_D	15mm	80,0 (3.15")	PUSH 19,63 cm ² (3.04 in ²)
		25mm		
		40mm		PULL 17,62 cm ² (2.73 in ²)
		50mm		
		65mm		
75mm				

	Standard Threads	"EM" Option
"B"	R 1/8 (1/8-28 BSPT)	1/8-27
"C"	M12X1,75	1/2-13
"D"	M8X1,25	5/16-18

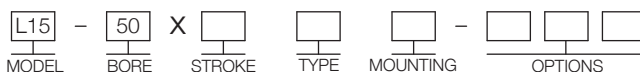
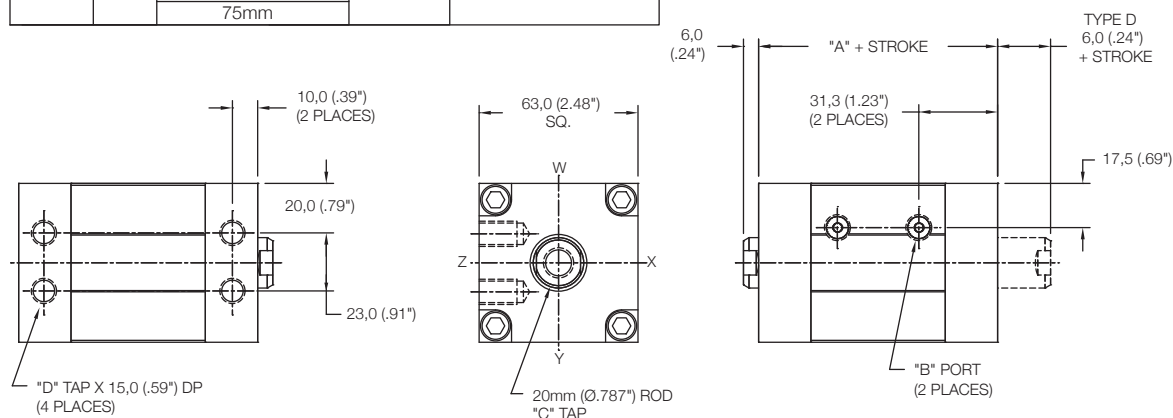

15mm - 75mm STROKE
(SEE STROKE RANGE)

BLANK - NO CODE
D - DOUBLE ROD

MB - BOTH END MOUNT
MF - FRONT MOUNT
MR - REAR MOUNT
MS - SIDE MOUNT

EM - INCH THREADS & PORT OPTIONS:

RS - MALE STUD FOR ROD END
(SEE PAGE 96 FOR DETAILS)

RF, RH, RN, RT, RV, RY - ROD EXTENSIONS
(SEE PAGE 96 FOR DETAILS)

L20 SERIES

HYDRAULIC CYLINDERS

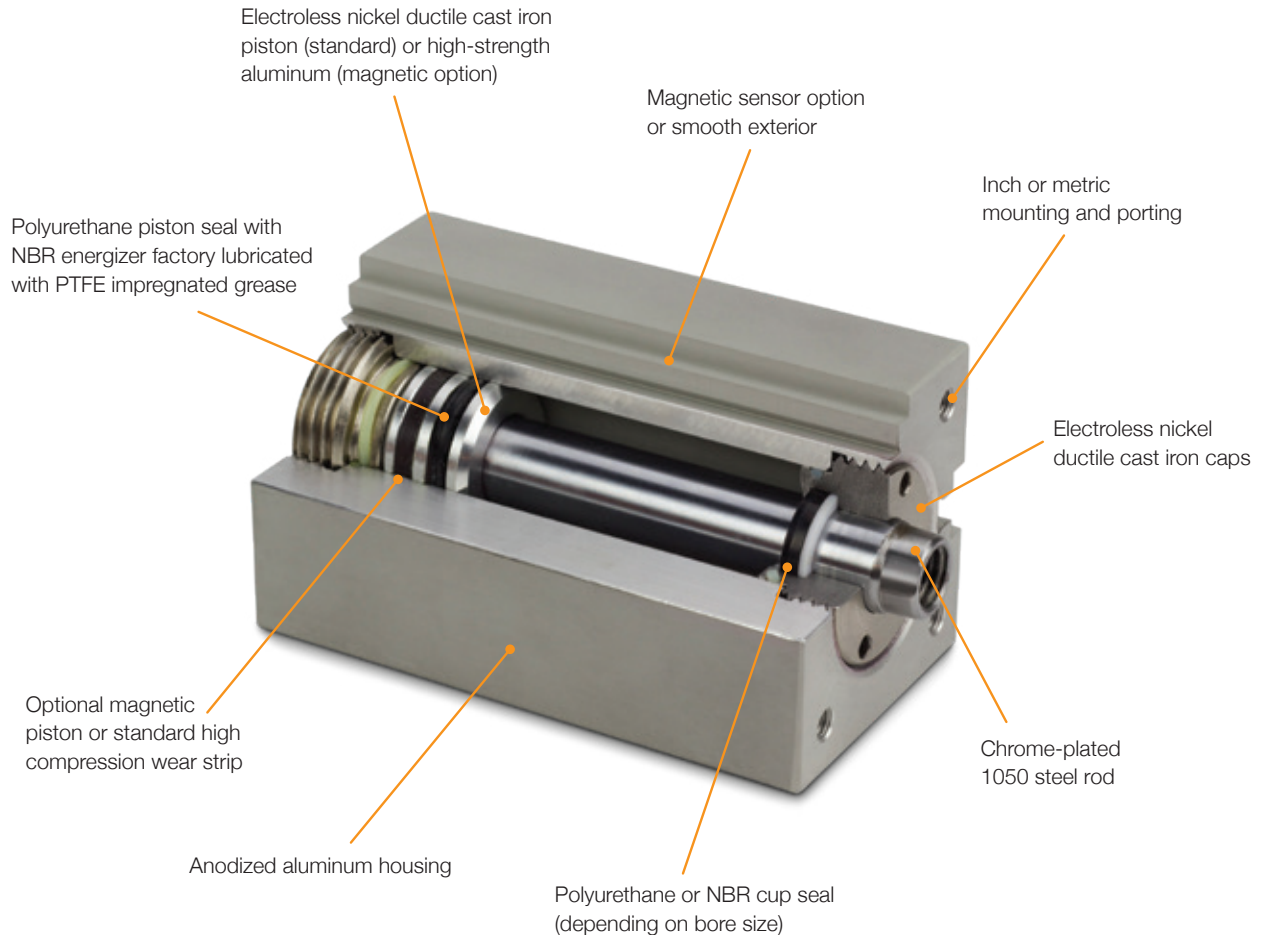

Common Features

Nason's L20 series hydraulic actuators were designed to be compact, long-lasting devices for today's demanding design requirements. They are offered in single and double rod configurations with inch or metric mounting and ports.

Compact Size

Nason L20 series cylinders were designed with today's automation equipment in mind. They offer more power in a smaller package than comparable NFPA style hydraulic cylinders without sacrificing performance.

Rugged Construction

The L20 series incorporates thick-walled, anodized aluminum housing. The rods are

chrome-plated 1050 steel riding in electroless nickel-plated ductile cast iron rod bearings. The piston on non-magnetic models is ductile cast iron with wear rings standard. The optional magnetic piston is manufactured from a high-strength aluminum. Rod wipers are standard on all models.

Versatile Design

The L20 series cylinders are metric in design (bore and rod sizes). They are offered in inch or metric mounting and porting. Due to their 100% machined design, they are easily customized by Nason.

Rebuildable

All L20 series cylinders are field-rebuildable.

How to Order

Example:

Part Number: L20-25X50MB-EMRM



MODEL
L20 - Medium Pressure Cylinder

BORE
25 - 25mm (.98")
32 - 32mm (1.26")
40 - 40mm (1.58")
50 - 50mm (1.97")
63 - 63mm (2.48")
76 - 76mm (3.00")
101 - 101mm (4.00")

STROKE
See Stroke Table

TYPE
Blank (NO CODE) - Double Acting, Single Rod
D - Double Acting, Double Rod

MOUNTING
MF - Threads on Front Face (Rod End)
MR - Threads on Rear Face (Opposite Rod)
MB - Threads on Both Faces
MT - Drilled Through and Counter bored for Bolt Clearance

MAGNETIC
Blank (No Code) - Standard "NO MAGNET" Piston
M - Magnetic Piston and Sensor Mounting

OPTIONS
EM - Inch Threads (Mounting, Ports and Rods)
RM - Rod Male Threads
RF - 5mm (.197") Rod Extension
RT - 10mm (.394") Rod Extension
RN - 15mm (.591") Rod Extension
RY - 20mm (.787") Rod Extension
RV - 25mm (.984") Rod Extension
RH - 35mm (1.38") Rod Extension

Packing: Urethane and Buna N
 Lubrication: PTFE impregnated grease
 Stroke Tolerance: +1,0mm/-0mm (+0.04"/-0")

Piston Area Chart

Bore	PUSH (ROD EXTEND)	PULL (ROD RETRACT)
25	4,91cm ² (.76in ²)	3,37cm ² (.52in ²)
32	8,04cm ² (1.25in ²)	5,50cm ² (.85in ²)
40	12,57cm ² (1.95in ²)	8,77cm ² (1.36in ²)
50	19,63cm ² (3.04in ²)	13,48cm ² (2.09in ²)
63	31,17cm ² (4.83in ²)	20,99cm ² (3.25in ²)
76	45,60cm ² (7.07in ²)	29,70cm ² (4.60in ²)
101	81,07cm ² (12.57in ²)	56,44cm ² (8.75in ²)

Stock Strokes

Bore	Stroke
25	25mm, 50mm, 75mm, 100mm (.98", 1.96", 2.95", 3.93")
32	
40	
50	
63	
76	
101	

5mm increments available with additional lead time

Cylinder Output Force Formula

Piston Area x Pressure = Output Force
Piston Area(in ²) x Pressure(PSI) = lbf (Pounds Force)
Piston Area(cm ²) x Pressure(kg/cm ²) = kgf (Kilograms Force)
Piston Area(cm ²) x Pressure(kg/cm ²) x 9.8 = Newtons
Piston Area(cm ²) x Pressure(Bar) x 10 = Newtons
Piston Area(cm ²) x Pressure(Bar) x 1.02 = kgf (Kilograms Force)

Cylinder Ratings

Bore	Pressure	Temperature
25	140 BAR (2030 PSI)	-10° C to 80° C (14° F to 176° F)
32	140 BAR (2030 PSI)	-10° C to 80° C (14° F to 176° F)
40	140 BAR (2030 PSI)	-23° C to 100° C (-10° F to 212° F)
50	120 BAR (1740 PSI)	-23° C to 100° C (-10° F to 212° F)
63	100 BAR (1450 PSI)	-23° C to 100° C (-10° F to 212° F)
76	100 BAR (1450 PSI)	-23° C to 100° C (-10° F to 212° F)
101	100 BAR (1450 PSI)	-23° C to 100° C (-10° F to 212° F)

Front Mount Cylinder "MF"

MODEL	TYPE	STANDARD STROKES	"A"	PISTON AREA
L20	_,D	25mm, 50mm, 75mm, 100mm	45,0(1.77")	PUSH 4,91 cm ² (0.76 in ²) PULL 3,37 cm ² (0.52 in ²)

	Standard Threads	"EM" Option
"B"	G1/8	#2 SAE
"C"	M10X1,5	3/8-24
"D"	M5X0,8	#10-32

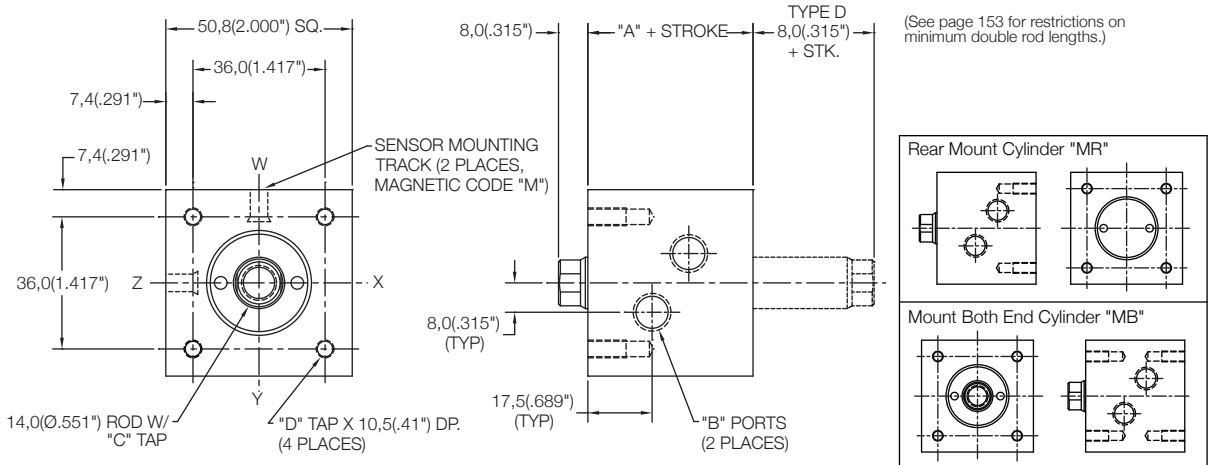

Thru Mount Cylinder "MT"

MODEL	TYPE	STANDARD STROKES	"A"	PISTON AREA
L20	_,D	25mm, 50mm, 75mm, 100mm	45,0(1.77")	PUSH 4,91 cm ² (0.76 in ²) PULL 3,37 cm ² (0.52 in ²)

	Standard Threads	"EM" Option
"B"	G1/8	#2 SAE
"C"	M10X1,5	3/8-24

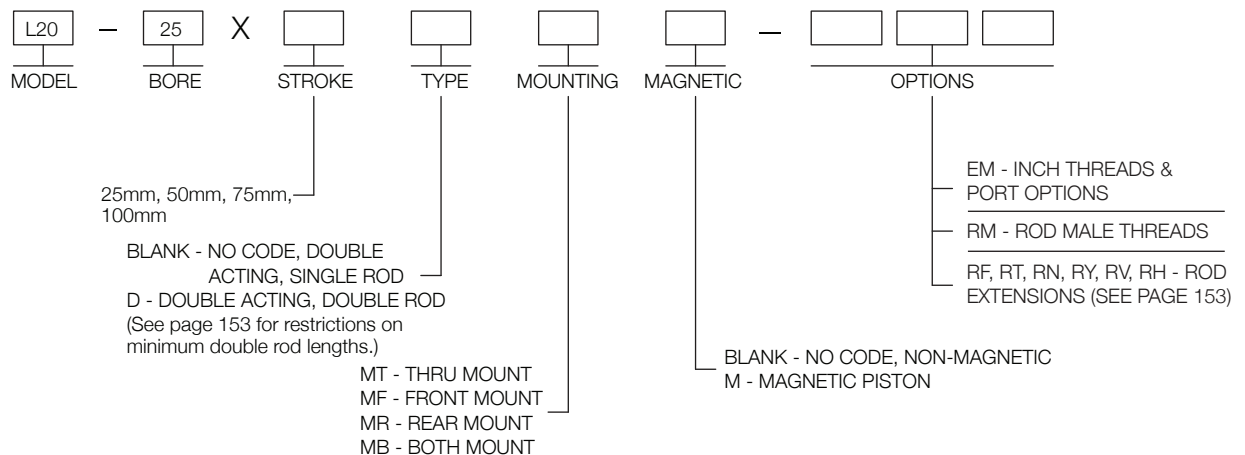
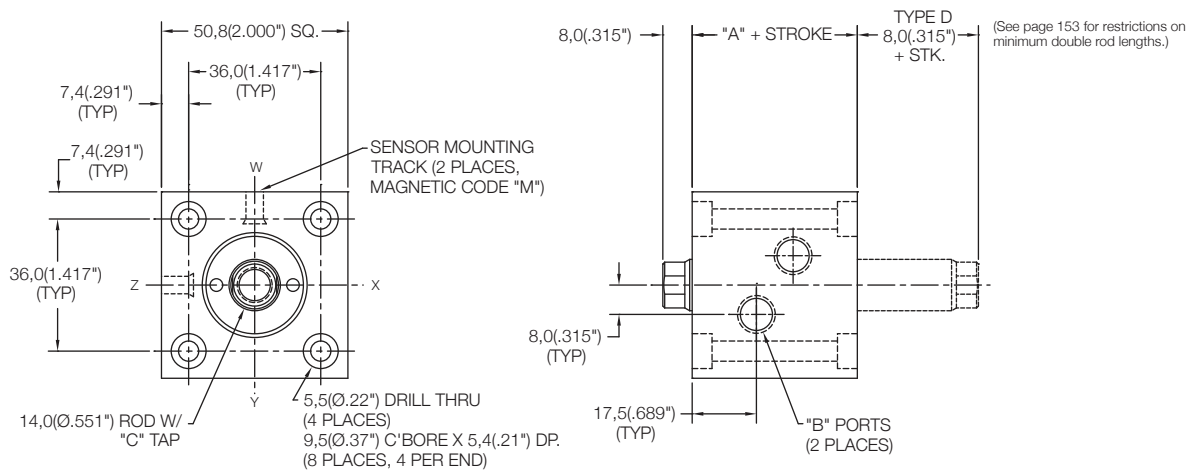

Front Mount Cylinder "MF"

MODEL	TYPE	STANDARD STROKES	"A"	PISTON AREA
L20	_,D	25mm, 50mm, 75mm, 100mm	51,0(2.01")	PUSH 8,04 cm ² (1.25 in ²) PULL 5,50 cm ² (0.85 in ²)

	Standard Threads	"EM" Option
"B"	G1/4	#4 SAE
"C"	M12X1,75	7/16-20
"D"	M6X1	1/4-28

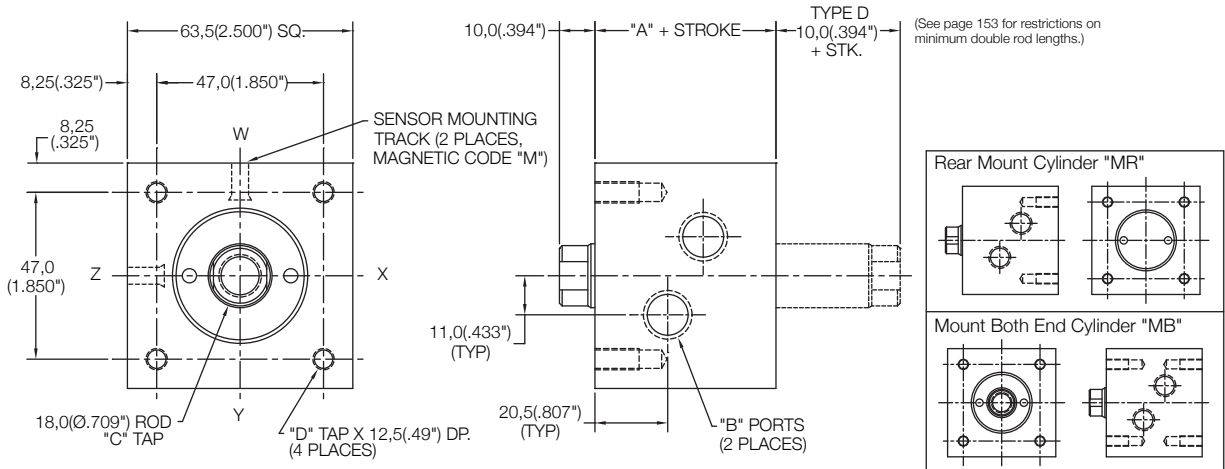

Thru Mount Cylinder "MT"

MODEL	TYPE	STANDARD STROKES	"A"	PISTON AREA
L20	_,D	25mm, 50mm, 75mm, 100mm	51,0(2.01")	PUSH 8,04 cm ² (1.25 in ²) PULL 5,50 cm ² (0.85 in ²)

	Standard Threads	"EM" Option
"B"	G1/4	#4 SAE
"C"	M12X1,75	7/16-20

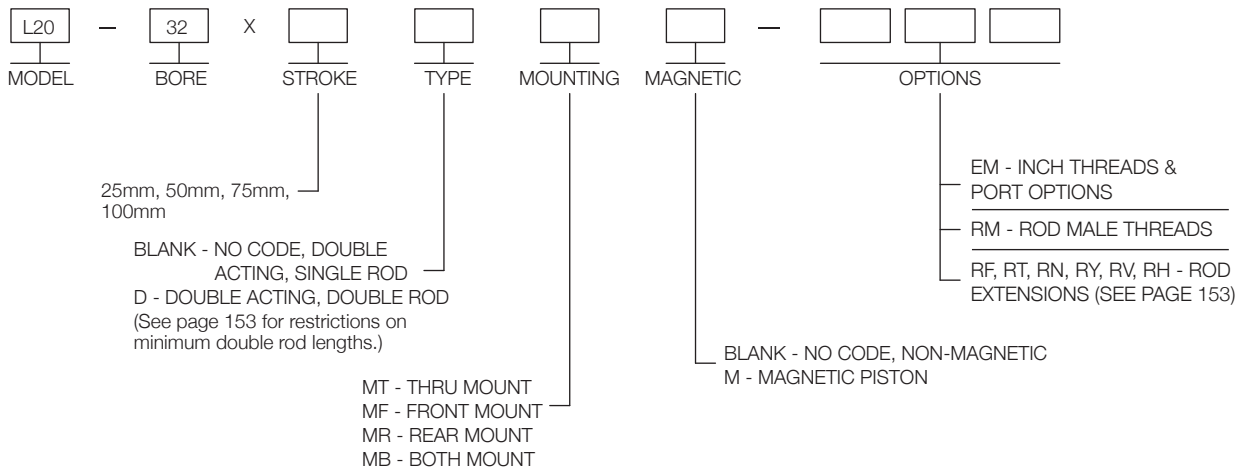
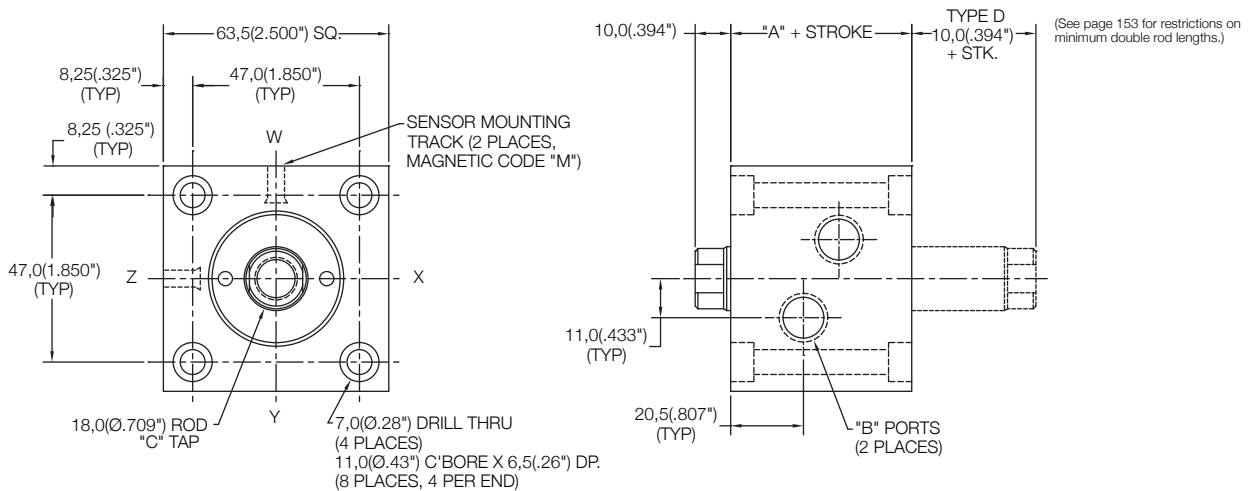

Front Mount Cylinder "MF"

MODEL	TYPE	STANDARD STROKES	"A"	PISTON AREA
L20	_,D	25mm, 50mm, 75mm, 100mm	55,0(2.17")	PUSH 12,57 cm ² (1.95 in ²) PULL 8,77 cm ² (1.36 in ²)

	Standard Threads	"EM" Option
"B"	G1/4	#4 SAE
"C"	M16X2	5/8-18
"D"	M8X1.25	5/16-24

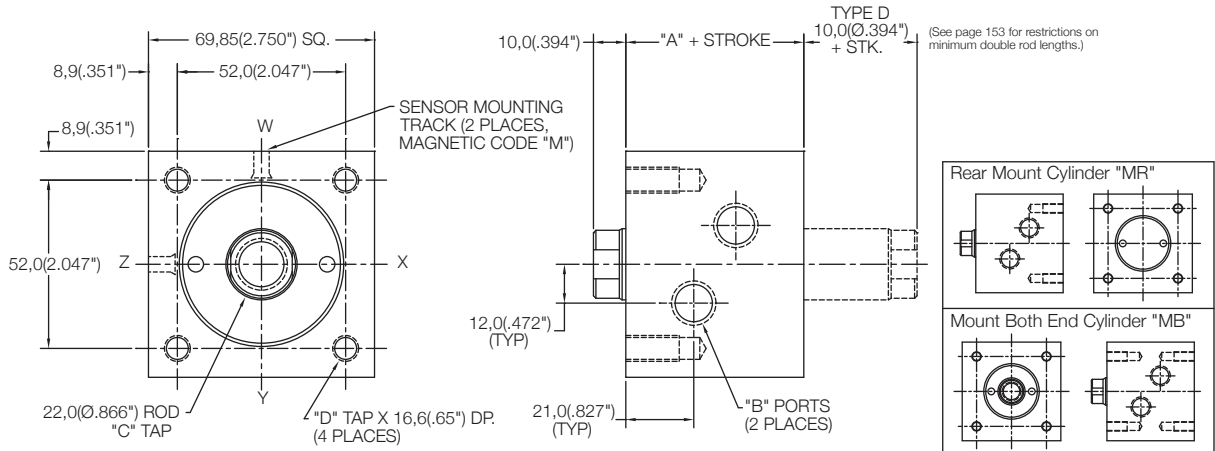

Thru Mount Cylinder "MT"

MODEL	TYPE	STANDARD STROKES	"A"	PISTON AREA
L20	_,D	25mm, 50mm, 75mm, 100mm	55,0(2.17")	PUSH 12,57 cm ² (1.95 in ²) PULL 8,77 cm ² (1.36 in ²)

	Standard Threads	"EM" Option
"B"	G1/4	#4 SAE
"C"	M16X2	5/8-18

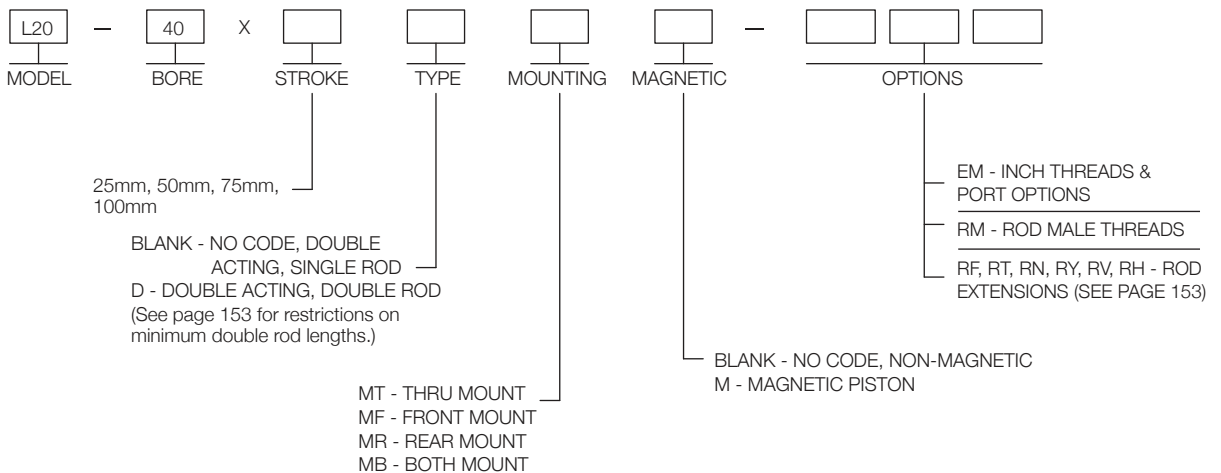
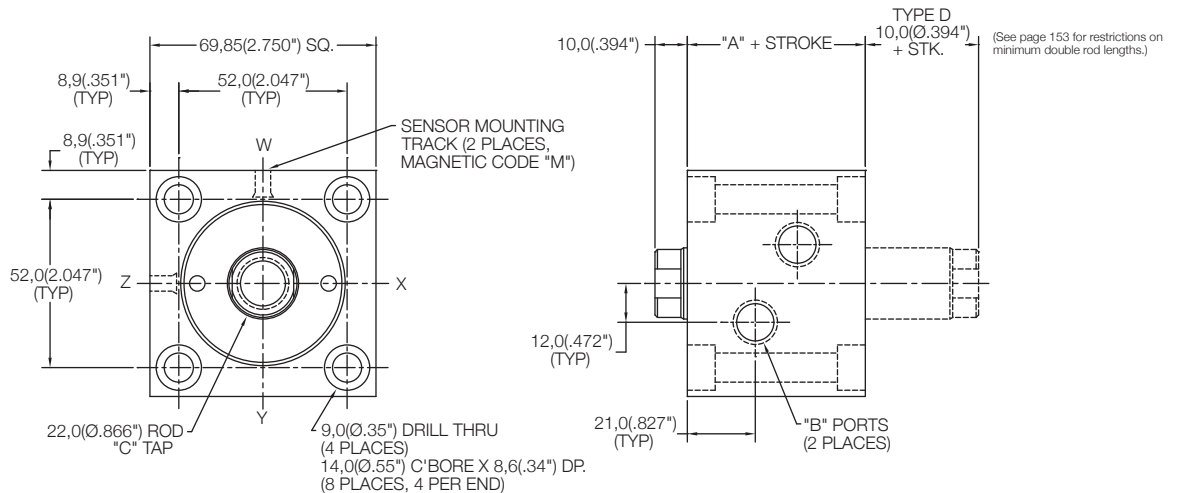

Front Mount Cylinder "MF"

MODEL	TYPE	STANDARD STROKES	"A"	PISTON AREA
L20	_D	25mm, 50mm, 75mm, 100mm	60,0(2.36")	PUSH 19,63 cm ² (3.04 in ²) PULL 13,48 cm ² (2.09 in ²)

	Standard Threads	"EM" Option
"B"	G1/4	#4 SAE
"C"	M20X2.5	3/4-16
"D"	M10X1.5	3/8-24

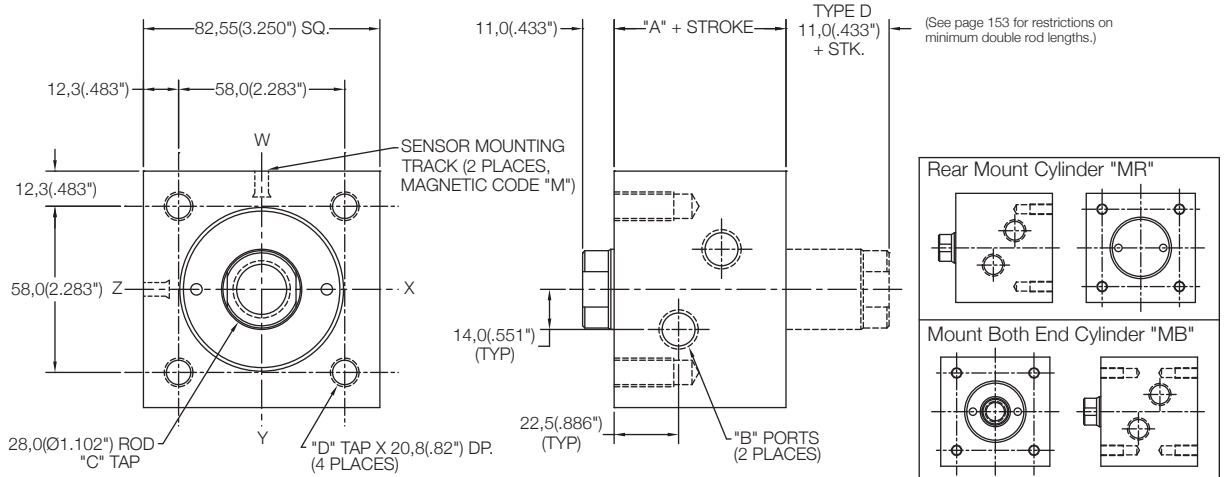

Thru Mount Cylinder "MT"

MODEL	TYPE	STANDARD STROKES	"A"	PISTON AREA
L20	_D	25mm, 50mm, 75mm, 100mm	60,0(2.36")	PUSH 19,63 cm ² (3.04 in ²) PULL 13,48 cm ² (2.09 in ²)

	Standard Threads	"EM" Option
"B"	G1/4	#4 SAE
"C"	M20X2.5	3/4-16

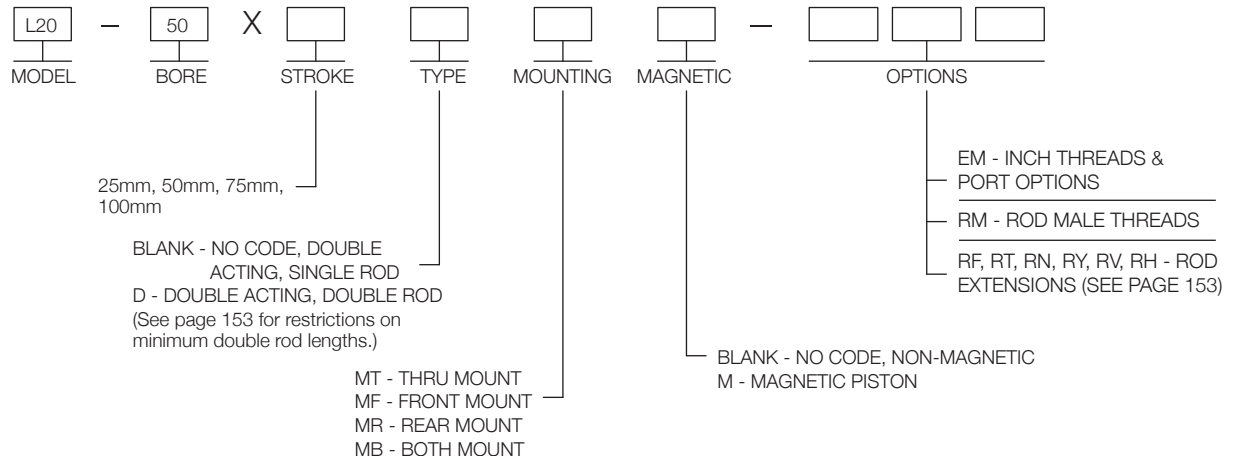
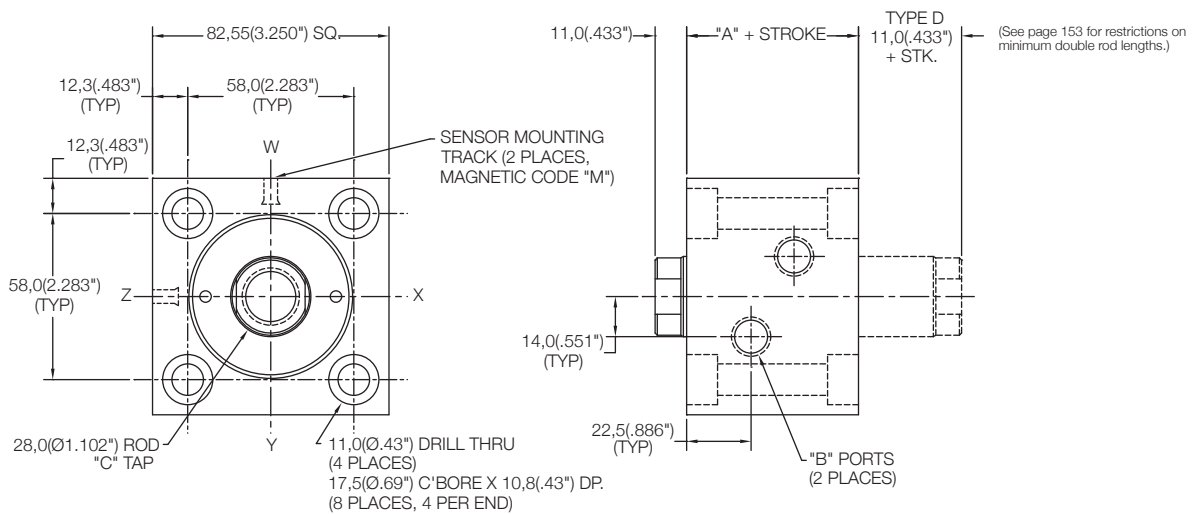

Front Mount Cylinder "MF"

MODEL	TYPE	STANDARD STROKES	"A"	PISTON AREA
L20	_,D	25mm, 50mm, 75mm, 100mm	67,0(2.64")	PUSH 31,17 cm ² (4.83 in ²) PULL 20,99 cm ² (3.25 in ²)

	Standard Threads	"EM" Option
"B"	G1/4	#4 SAE
"C"	M27X3	1-14
"D"	M12X1.75	1/2-20

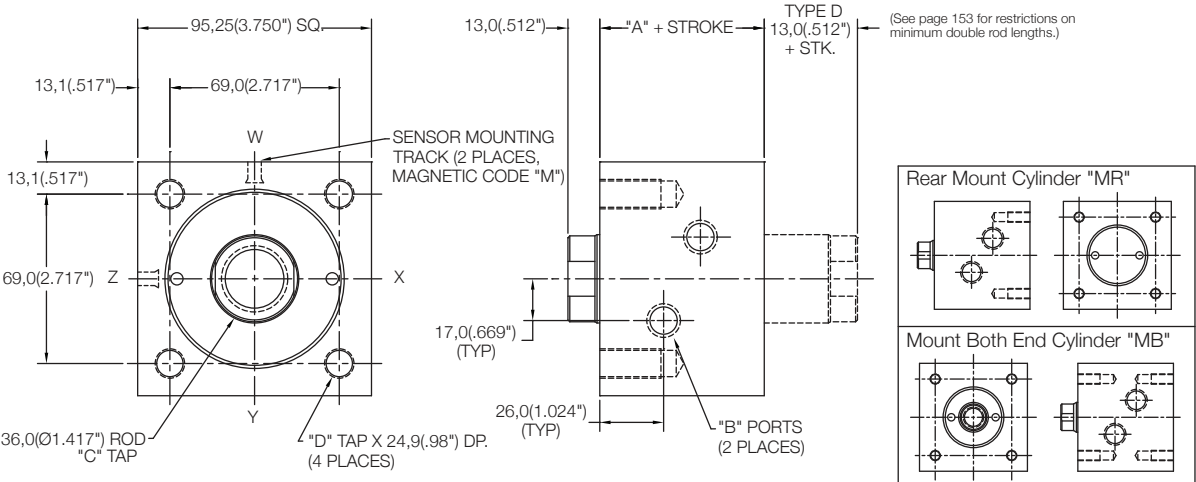

Thru Mount Cylinder "MT"

MODEL	TYPE	STANDARD STROKES	"A"	PISTON AREA
L20	_,D	25mm, 50mm, 75mm, 100mm	67,0(2.64")	PUSH 31,17 cm ² (4.83 in ²) PULL 20,99 cm ² (3.25 in ²)

	Standard Threads	"EM" Option
"B"	G1/4	#4 SAE
"C"	M27X3	1-14

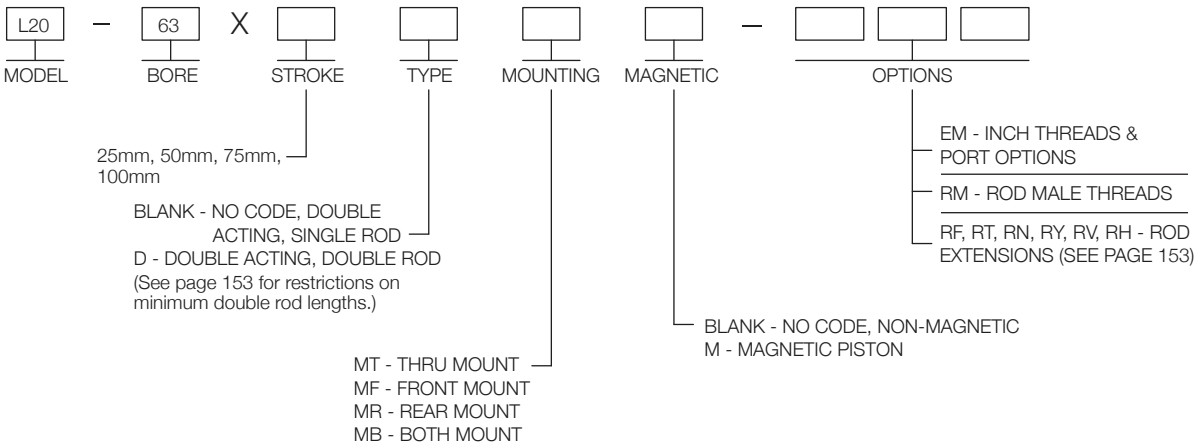
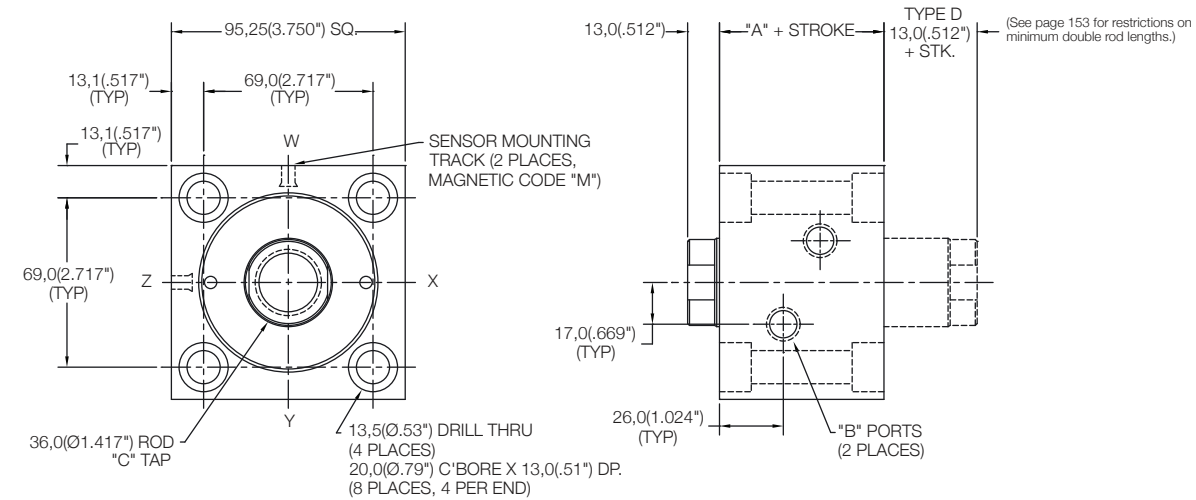

Front Mount Cylinder "MF"

MODEL	TYPE	STANDARD STROKES	"A"	PISTON AREA
L20	_,D	25mm, 50mm, 75mm, 100mm	78,0(3.07")	PUSH 45,60 cm ² (7.07 in ²) PULL 29,70 cm ² (4.60 in ²)

	Standard Threads	"EM" Option
"B"	G3/8	#6 SAE
"C"	M33X3.5	1 1/4-12
"D"	M14X2	5/8-18

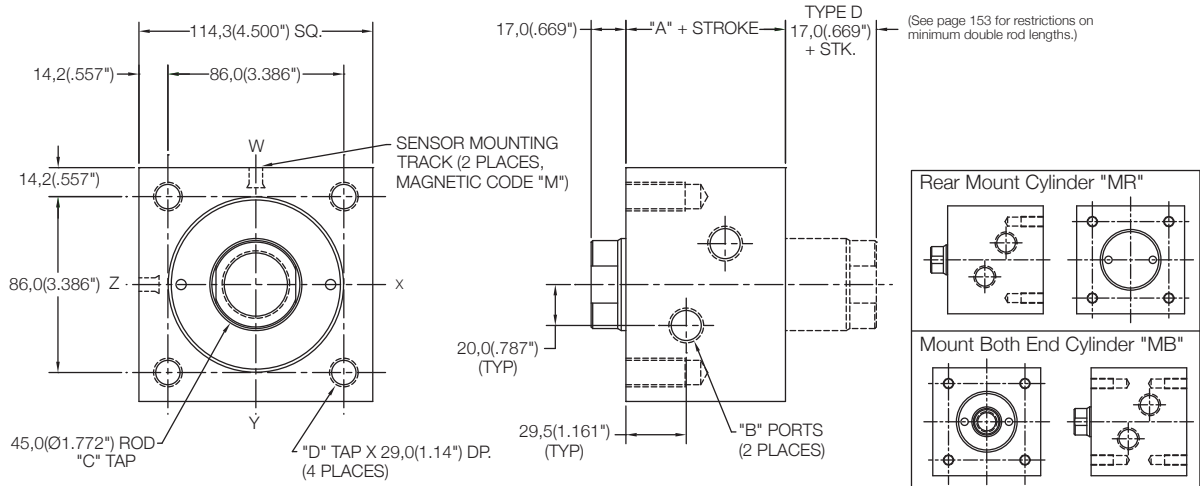

Thru Mount Cylinder "MT"

MODEL	TYPE	STANDARD STROKES	"A"	PISTON AREA
L20	_,D	25mm, 50mm, 75mm, 100mm	78,0(3.07")	PUSH 45,60 cm ² (7.07 in ²) PULL 29,70 cm ² (4.60 in ²)

	Standard Threads	"EM" Option
"B"	G3/8	#6 SAE
"C"	M33X3.5	1 1/4-12

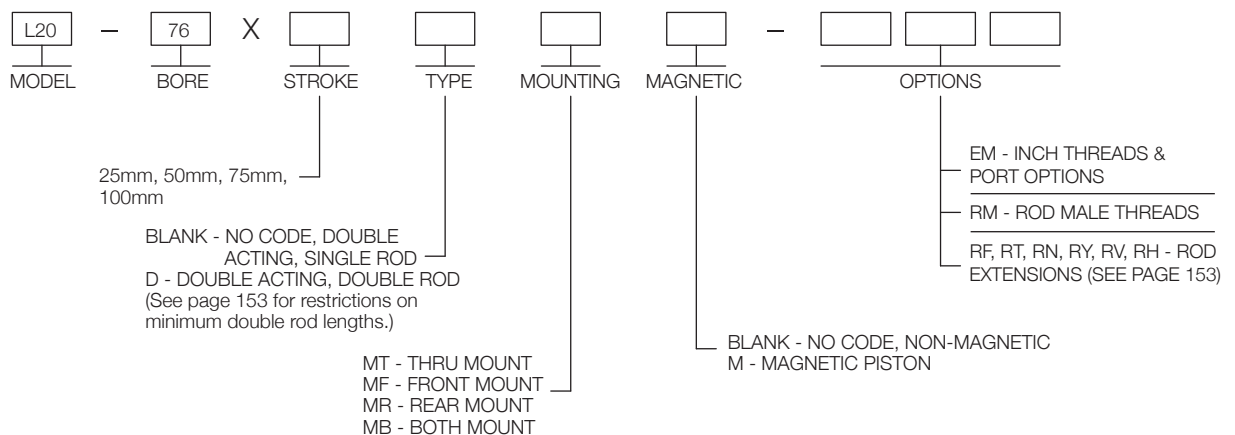
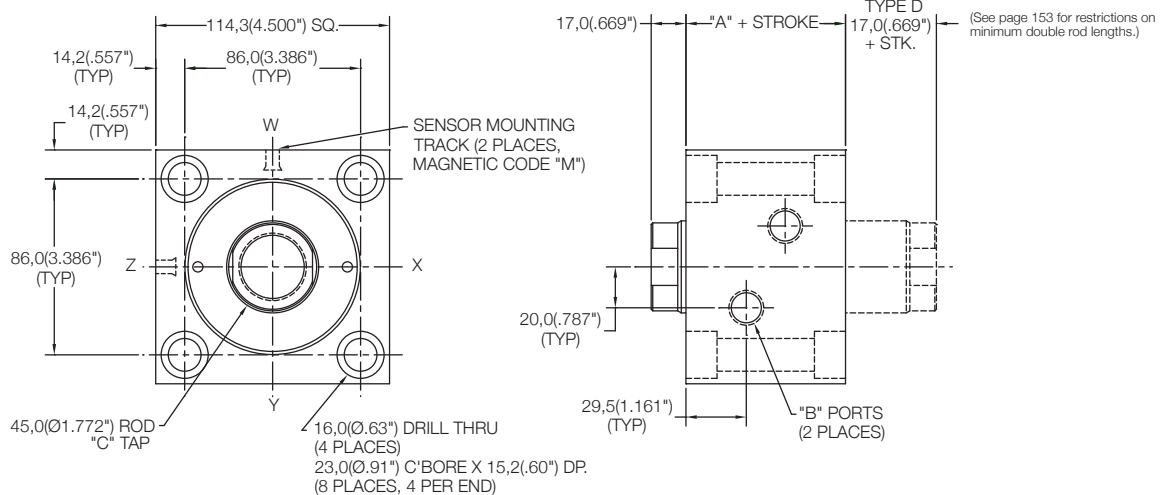

Front Mount Cylinder "MF"

MODEL	TYPE	STANDARD STROKES	"A"	PISTON AREA
L20	_,D	25mm, 50mm, 75mm, 100mm	96,0(3.78")	PUSH 81,07 cm ² (12.57 in ²) PULL 56,44 cm ² (8.75 in ²)

	Standard Threads	"EM" Option
"B"	G3/8	#6 SAE
"C"	M42X4.5	1 1/2-12
"D"	M16X2	5/8-18

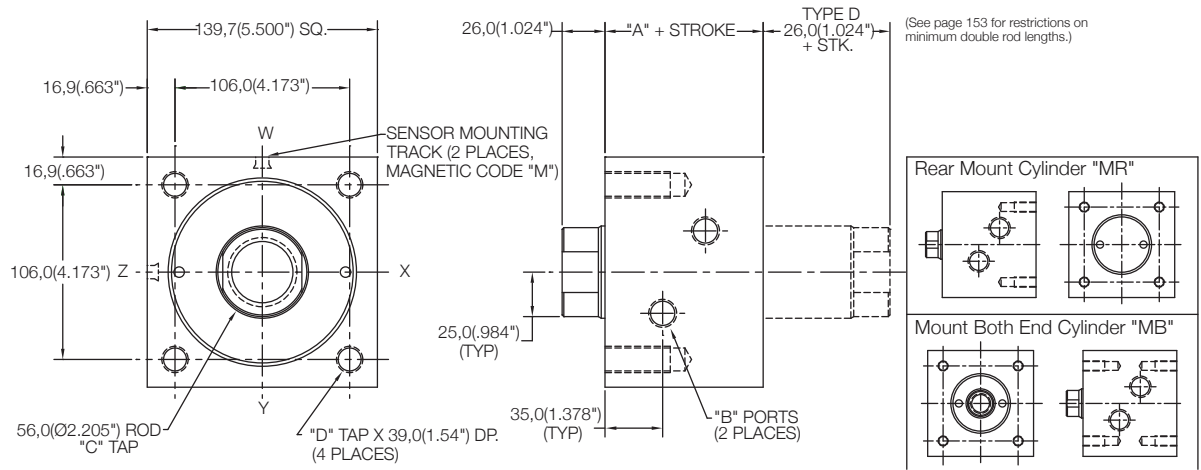

Thru Mount Cylinder "MT"

MODEL	TYPE	STANDARD STROKES	"A"	PISTON AREA
L20	_,D	25mm, 50mm, 75mm, 100mm	96,0(3.78")	PUSH 81,07 cm ² (12.57 in ²) PULL 56,44 cm ² (8.75 in ²)

	Standard Threads	"EM" Option
"B"	G3/8	#6 SAE
"C"	M42X4.5	1 1/2-12

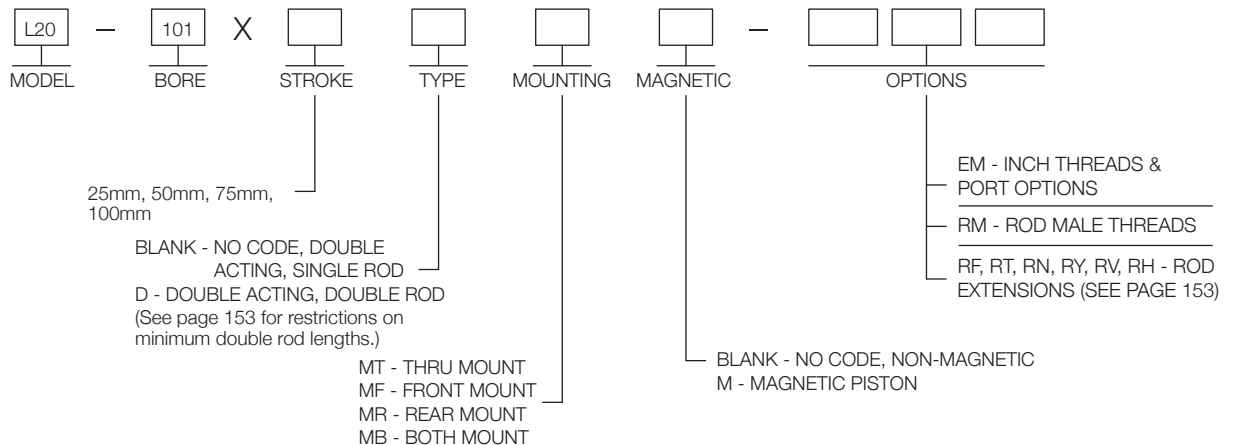
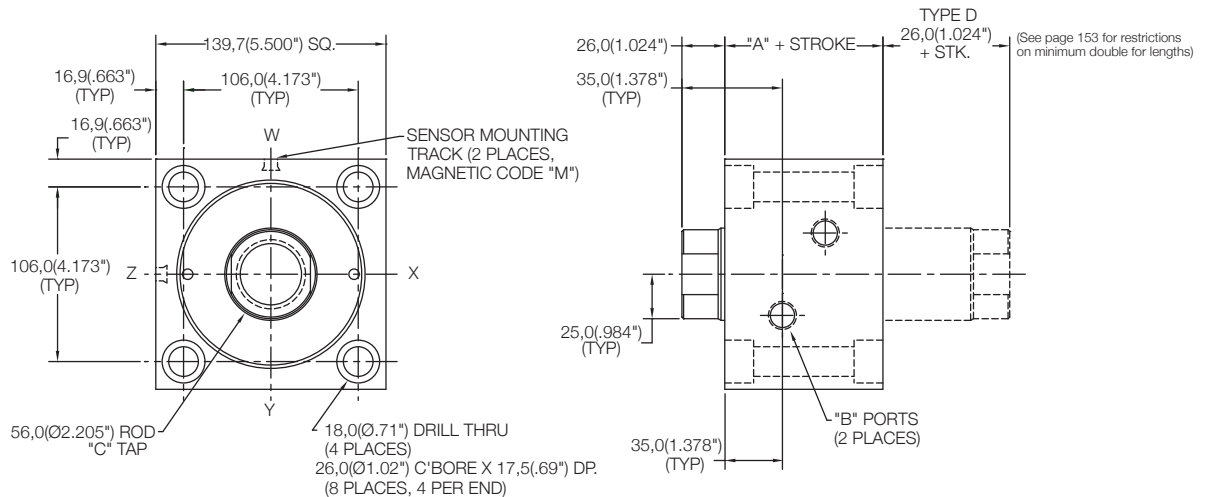

**Male Thread
Option - "RM"**

Bore	"A"	"B"	"EM" Option	"B"
25	M10X1.25	16 (.63")	1/2-20	18 (.71")
32	M12X1.25	18 (.71")	9/16-18	25 (.98")
40	M16X1.5	22 (.87")	3/4-16	30 (1.18")
50	M20X1.5	28 (1.10")	7/8-14	35 (1.38")
63	M27X2	36 (1.42")	1 1/4-12	45 (1.77")
76	M33X2	45 (1.77")	1 1/2-12	56 (2.20")
101	M42X2	56 (2.20")	1 3/4-12	70 (2.76")

Dimensions above are the same for double rod cylinders.

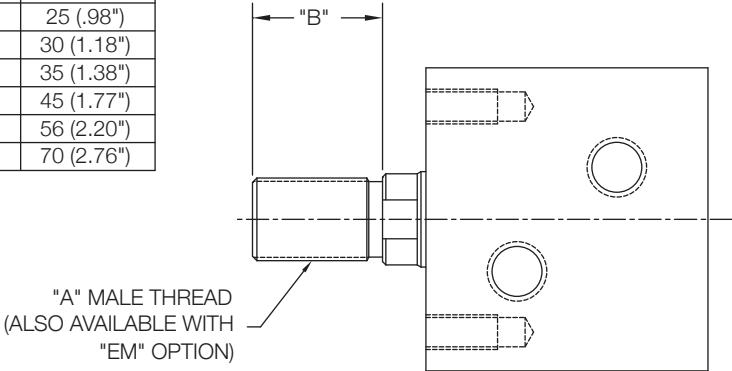

**Rod End Detail
See Chart Below**

Bore	Ø"A"	"B"	"C"
25	13 (.51")	6 (.24")	12 (.47")
32	17 (.67")	8 (.31")	15 (.59")
40	21 (.83")	8 (.31")	19 (.75")
50	27 (1.06")	9 (.35")	24 (.94")
63	35 (1.38")	11 (.43")	32 (1.26")
76	43 (1.69")	13 (.51")	39 (1.54")
101	54 (2.13")	22 (.87")	48 (1.89")

Dimensions above are the same for double rod cylinders.

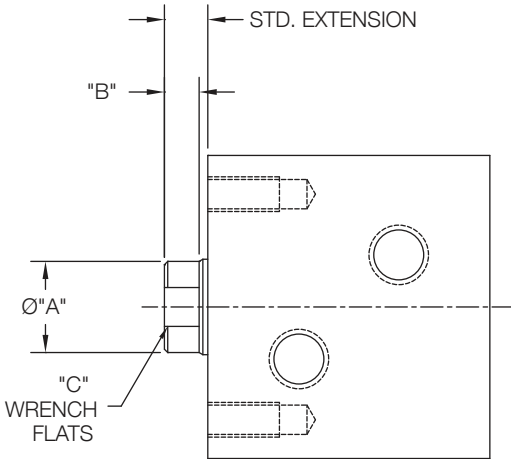

Rod Extensions Option - See Chart Below

Extensions	"RF"	"RT"	"RN"	"RY"	"RV"	"RH"
Length	5 (.20")	10 (.39")	15 (.59")	20 (.79")	25 (.98")	35 (1.38")

For standard extension, see catalog pages.

If cylinder is double ended, extension will be on both ends.

Consult factory for single ended extension on a double ended cylinder.

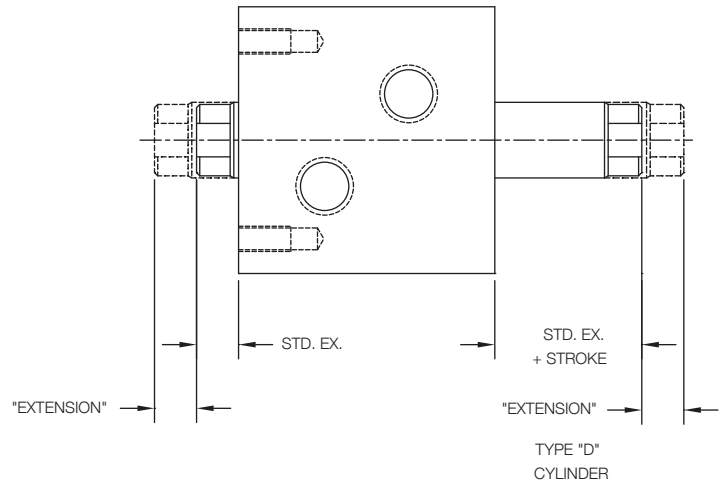

Minimum Rod Extension for Double Rod Option (Type "D") - See Chart Below

Standard double rod cylinders must have "X" dimensions greater than or equal to those listed in the table below. Corresponding rod extensions will be added to cylinders which do not meet this minimum length, so that standard extension plus stroke adds up to "X" MIN. This applies only to rear rod.

Bore	STD. Ex.	"X" MIN	For Strokes Less Than
25	8 (.31")	23 (.91")	15 (.59")
32	10 (.39")	25 (.98")	15 (.59")
40	10 (.39")	30 (1.18")	20 (.79")
50	11 (.43")	31 (1.22")	20 (.79")
63	13 (.51")	38 (1.50")	25 (.98")
76	17 (.67")	42 (1.65")	25 (.98")
101	26 (1.02")	51 (2.00")	25 (.98")

*Single rod cylinders and cylinders with "RM" rod male thread option do not have this restriction.

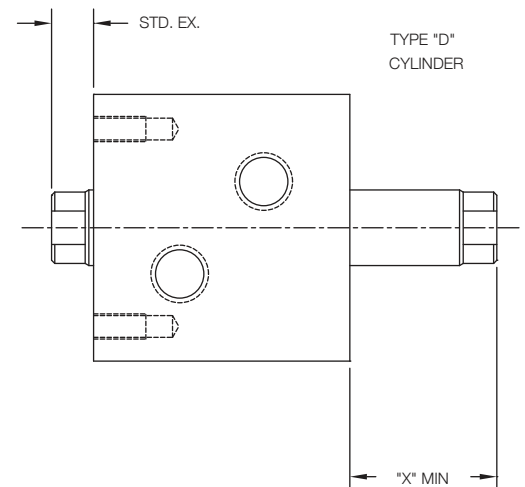

L30 SERIES

HYDRAULIC CYLINDERS

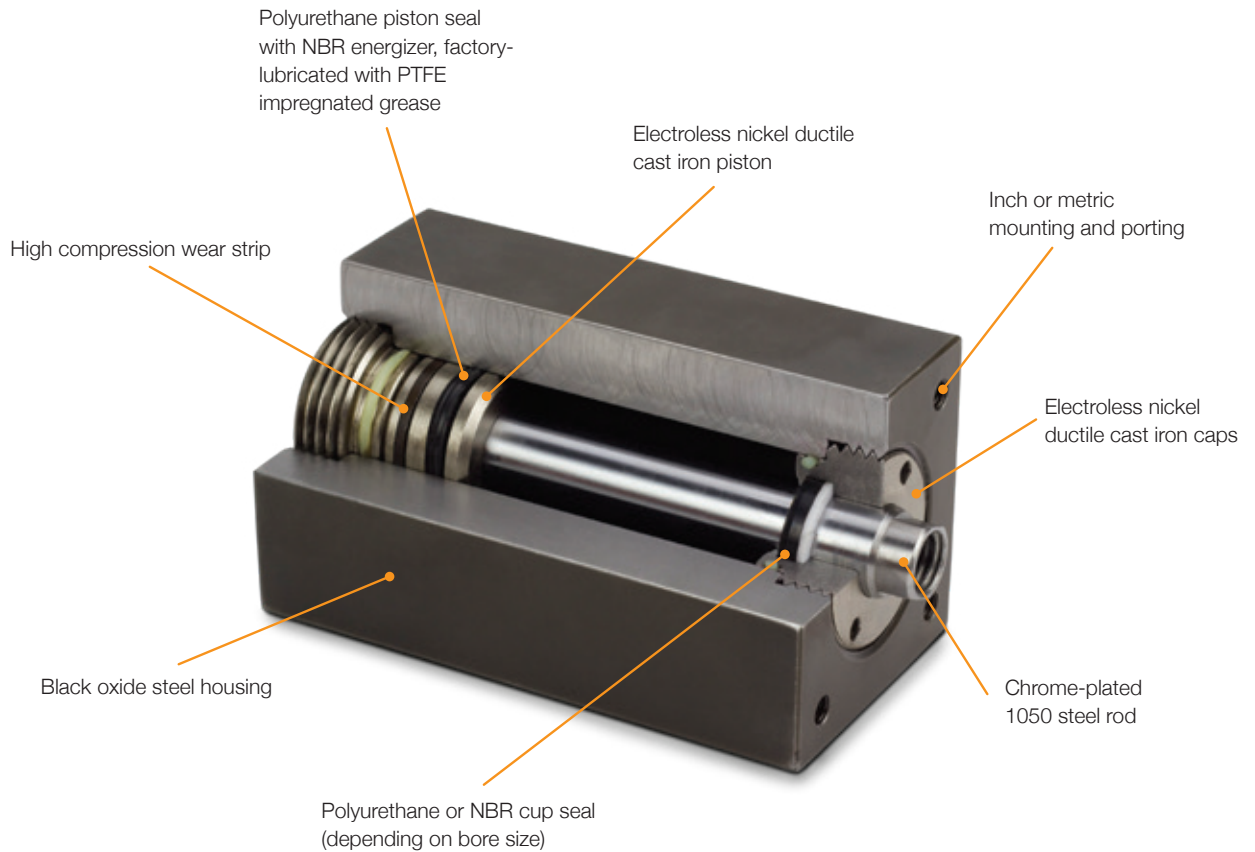

Common Features

Nason's L30 series hydraulic actuators were designed to be compact, long-lasting devices for today's demanding design requirements. They are offered in single and double rod configurations with inch or metric mounting and ports.

Compact Size

Nason L30 series cylinders were designed with today's automation equipment in mind. They offer more power in a smaller package than comparable NFPA style hydraulic cylinders without sacrificing performance.

Rugged Construction

The L30 series incorporates thick-walled steel housing. The rods are chrome-plated 1050 steel riding in electroless nickel-plated ductile cast iron rod bearings. The piston is ductile cast iron with wear rings standard. Rod wipers are standard on all models.

Versatile Design

The L30 series cylinders are metric in design (bore and rod sizes). They are offered in inch or metric mounting and porting. Due to their 100% machined design, they are easily customized by Nason.

Rebuildable

All L30 series cylinders are field-rebuildable.

How to Order

Example:

Part Number: L30-25X50MB-EMRM

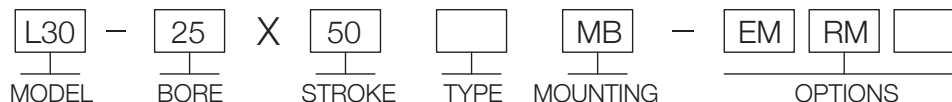

MODEL
L30 - High Pressure Cylinder

BORE
25 - 25mm (.98")
32 - 32mm (1.26")
40 - 40mm (1.58")
50 - 50mm (1.97")
63 - 63mm (2.48")
76 - 76mm (3.00")

STROKE
See Stroke Table

TYPE
Blank (NO CODE) - Double Acting, Single Rod
D - Double Acting, Double Rod

MOUNTING
MF - Threads on Front Face (Rod End)
MR - Threads on Rear Face (Opposite Rod)
MB - Threads on Both Faces
MT - Drilled Through and Counter bored for Bolt Clearance

OPTIONS
EM - Inch Threads (Mounting, Ports and Rods)
RM - Rod Male Threads
RF - 5mm (.197") Rod Extension
RT - 10mm (.394") Rod Extension
RN - 15mm (.591") Rod Extension
RY - 20mm (.787") Rod Extension
RV - 25mm (.984") Rod Extension
RH - 35mm (1.38") Rod Extension

Packing: Urethane and Buna N
 Lubrication: PTFE impregnated grease
 Stroke Tolerance: +0,75mm/-0mm (+0.03"/-0")

Piston Area Chart

Bore	PUSH (ROD EXTEND)	PULL (ROD RETRACT)
25	4,91cm ² (.76in ²)	3,37cm ² (.52in ²)
32	8,04cm ² (1.25in ²)	5,50cm ² (.85in ²)
40	12,57cm ² (1.95in ²)	8,77cm ² (1.36in ²)
50	19,63cm ² (3.04in ²)	13,48cm ² (2.09in ²)
63	31,17cm ² (4.83in ²)	20,99cm ² (3.25in ²)
76	45,60cm ² (7.07in ²)	29,70cm ² (4.60in ²)

Stock Strokes

Bore	Stroke
25	25mm, 50mm, 75mm, 100mm (.98", 1.96", 2.95", 3.93")
32	
40	
50	
63	
76	

5mm increments available with additional lead time

Cylinder Output Force Formula

Piston Area x Pressure = Output Force
Piston Area(in ²) x Pressure(PSI) = lbf (Pounds Force)
Piston Area(cm ²) x Pressure(kg/cm ²) = kgf (Kilograms Force)
Piston Area(cm ²) x Pressure(kg/cm ²) x 9.8 = Newtons
Piston Area(cm ²) x Pressure(Bar) x 10 = Newtons
Piston Area(cm ²) x Pressure(Bar) x 1.02 = kgf (Kilograms Force)

Cylinder Ratings

Bore	Pressure	Temperature
25	206 BAR (3000 PSI)	-10° C to 80° C (14° F to 176° F)
32	206 BAR (3000 PSI)	-10° C to 80° C (14° F to 176° F)
40	206 BAR (3000 PSI)	-23° C to 100° C (-10° F to 212° F)
50	206 BAR (3000 PSI)	-23° C to 100° C (-10° F to 212° F)
63	206 BAR (3000 PSI)	-23° C to 100° C (-10° F to 212° F)
76	206 BAR (3000 PSI)	-23° C to 100° C (-10° F to 212° F)

Front Mount Cylinder "MF"

MODEL	TYPE	STANDARD STROKES	"A"	PISTON AREA
L30	_,D	25mm, 50mm, 75mm, 100mm	45,0(1.77")	PUSH 4,91 cm ² (0.76 in ²) PULL 3,37 cm ² (0.52 in ²)

	Standard Threads	"EM" Option
"B"	G1/8	#2 SAE
"C"	M10X1,5	3/8-24
"D"	M5X0,8	#10-32

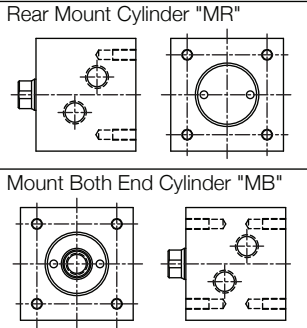
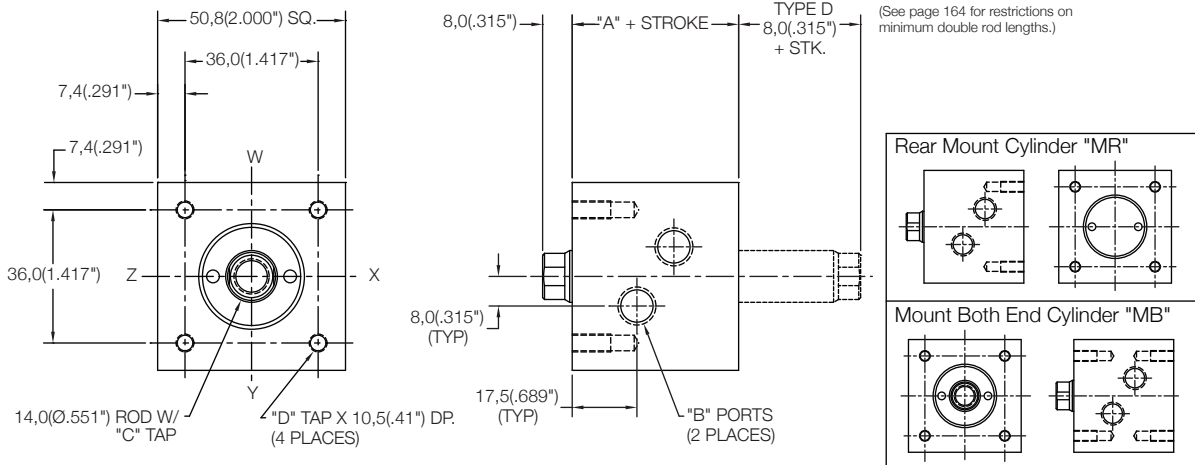

Thru Mount Cylinder "MT"

MODEL	TYPE	STANDARD STROKES	"A"	PISTON AREA
L30	_,D	25mm, 50mm, 75mm, 100mm	45,0(1.77")	PUSH 4,91 cm ² (0.76 in ²) PULL 3,37 cm ² (0.52 in ²)

	Standard Threads	"EM" Option
"B"	G1/8	#2 SAE
"C"	M10X1,5	3/8-24

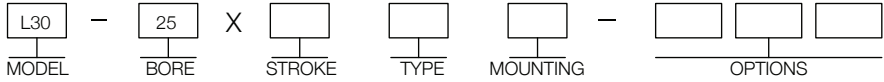
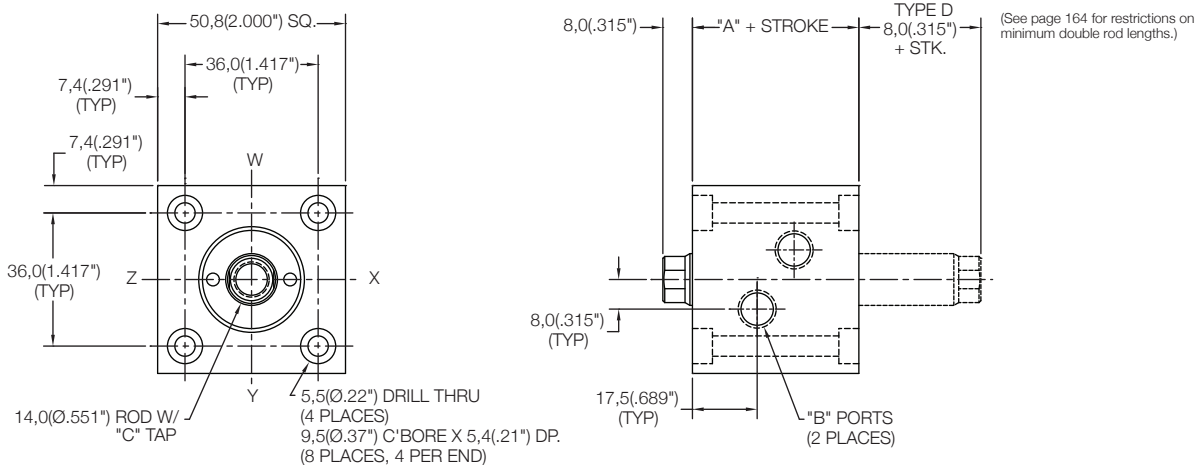

25mm, 50mm, 75mm, 100mm

BLANK - NO CODE, DOUBLE ACTING, SINGLE ROD
D - DOUBLE ACTING, DOUBLE ROD
(See page 164 for restrictions on minimum double rod lengths.)

MT - THRU MOUNT
MF - FRONT MOUNT
MR - REAR MOUNT
MB - BOTH MOUNT

EM - INCH THREADS & PORT OPTIONS
RM - ROD MALE THREADS
RF, RT, RN, RY, RV, RH - ROD EXTENSIONS (SEE PAGE 164)

Front Mount Cylinder "MF"

MODEL	TYPE	STANDARD STROKES	"A"	PISTON AREA
L30	_,D	25mm, 50mm, 75mm, 100mm	51,0(2.01")	PUSH 8,04 cm ² (1.25 in ²) PULL 5,50 cm ² (0.85 in ²)

	Standard Threads	"EM" Option
"B"	G1/4	#4 SAE
"C"	M12X1,75	7/16-20
"D"	M6X1	1/4-28

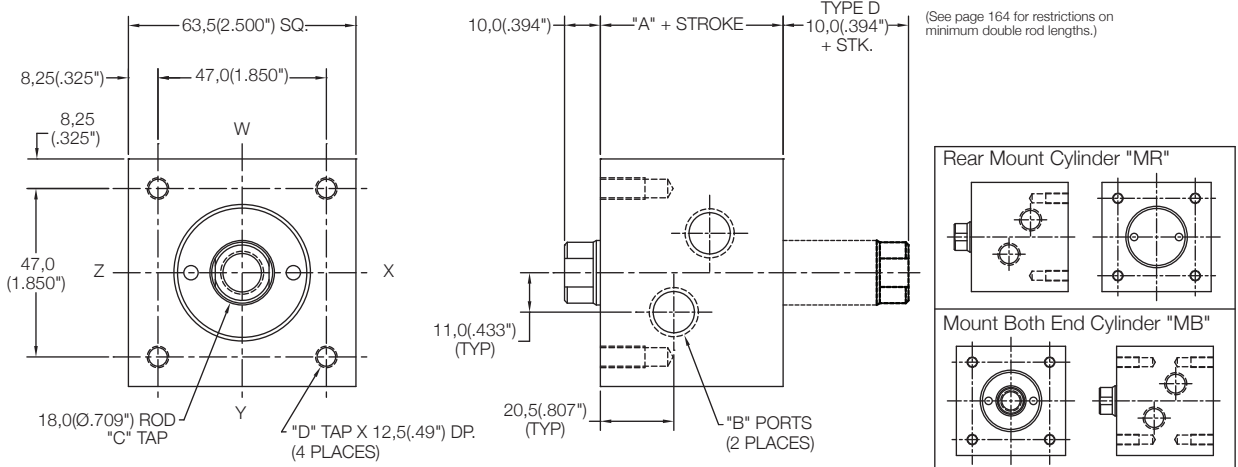

Thru Mount Cylinder "MT"

MODEL	TYPE	STANDARD STROKES	"A"	PISTON AREA
L30	_,D	25mm, 50mm, 75mm, 100mm	51,0(2.01")	PUSH 8,04 cm ² (1.25 in ²) PULL 5,50 cm ² (0.85 in ²)

	Standard Threads	"EM" Option
"B"	G1/4	#4 SAE
"C"	M12X1,75	7/16-20

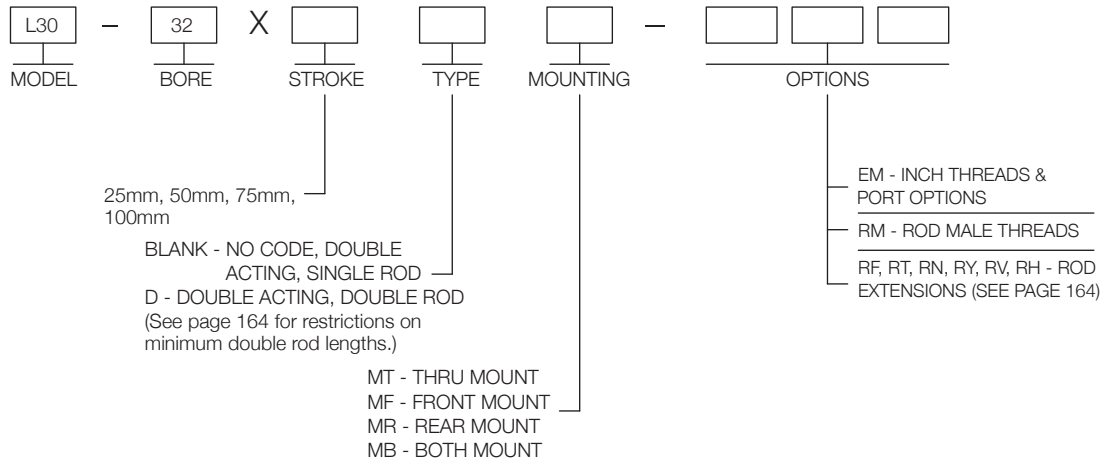
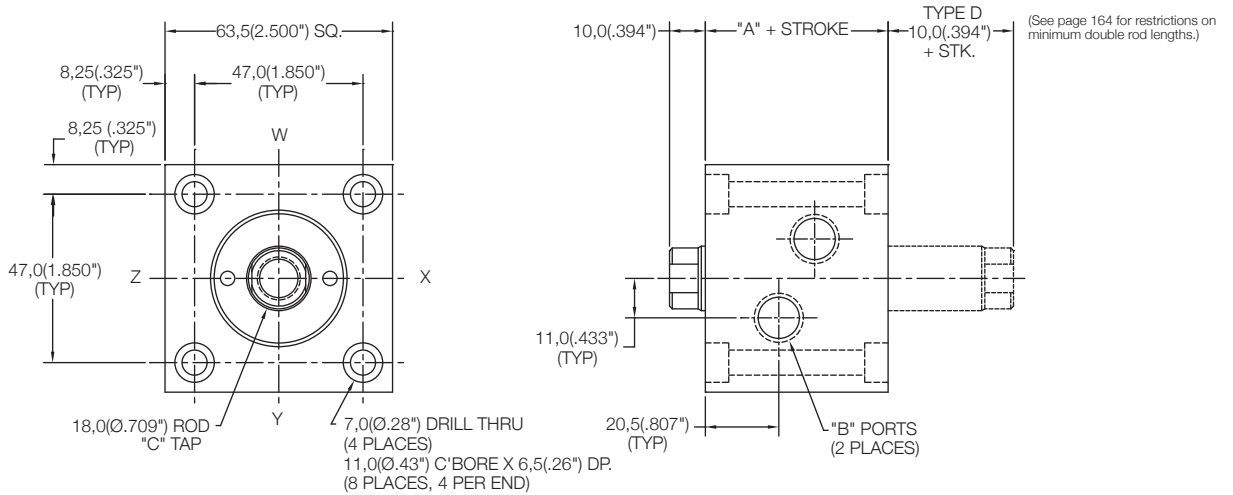

Front Mount Cylinder "MF"

MODEL	TYPE	STANDARD STROKES	"A"	PISTON AREA
L30	_,D	25mm, 50mm, 75mm, 100mm	55,0(2.17")	PUSH 12,57 cm ² (1.95 in ²) PULL 8,77 cm ² (1.36 in ²)

	Standard Threads	"EM" Option
"B"	G1/4	#4 SAE
"C"	M16X2	5/8-18
"D"	M8X1.25	5/16-24

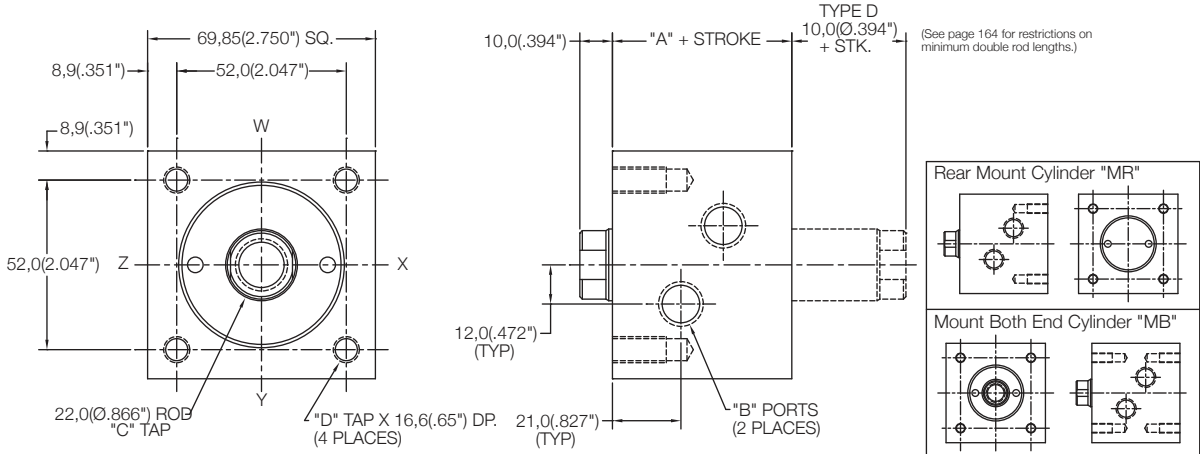

Thru Mount Cylinder "MT"

MODEL	TYPE	STANDARD STROKES	"A"	PISTON AREA
L30	_,D	25mm, 50mm, 75mm, 100mm	55,0(2.17")	PUSH 12,57 cm ² (1.95 in ²) PULL 8,77 cm ² (1.36 in ²)

	Standard Threads	"EM" Option
"B"	G1/4	#4 SAE
"C"	M16X2	5/8-18

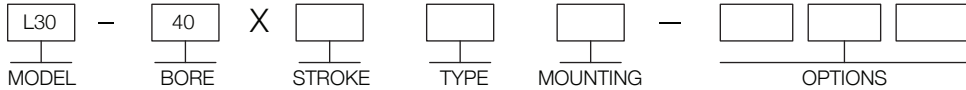
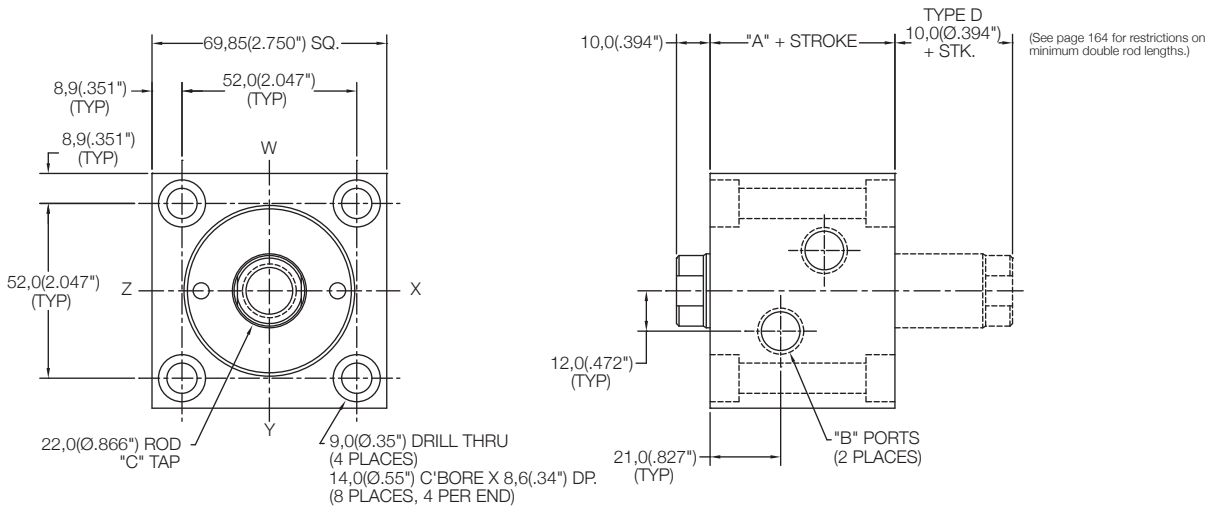

25mm, 50mm, 75mm, 100mm

BLANK - NO CODE, DOUBLE ACTING, SINGLE ROD
D - DOUBLE ACTING, DOUBLE ROD
(See page 164 for restrictions on minimum double rod lengths.)

MT - THRU MOUNT
MF - FRONT MOUNT
MR - REAR MOUNT
MB - BOTH MOUNT

EM - INCH THREADS & PORT OPTIONS
RM - ROD MALE THREADS
RF, RT, RN, RY, RV, RH - ROD EXTENSIONS (SEE PAGE 164)

Front Mount Cylinder "MF"

MODEL	TYPE	STANDARD STROKES	"A"	PISTON AREA
L30	_,D	25mm, 50mm, 75mm, 100mm	60,0(2.36")	PUSH 19,63 cm ² (3.04 in ²) PULL 13,48 cm ² (2.09 in ²)

	Standard Threads	"EM" Option
"B"	G1/4	#4 SAE
"C"	M20X2.5	3/4-16
"D"	M10X1.5	3/8-24

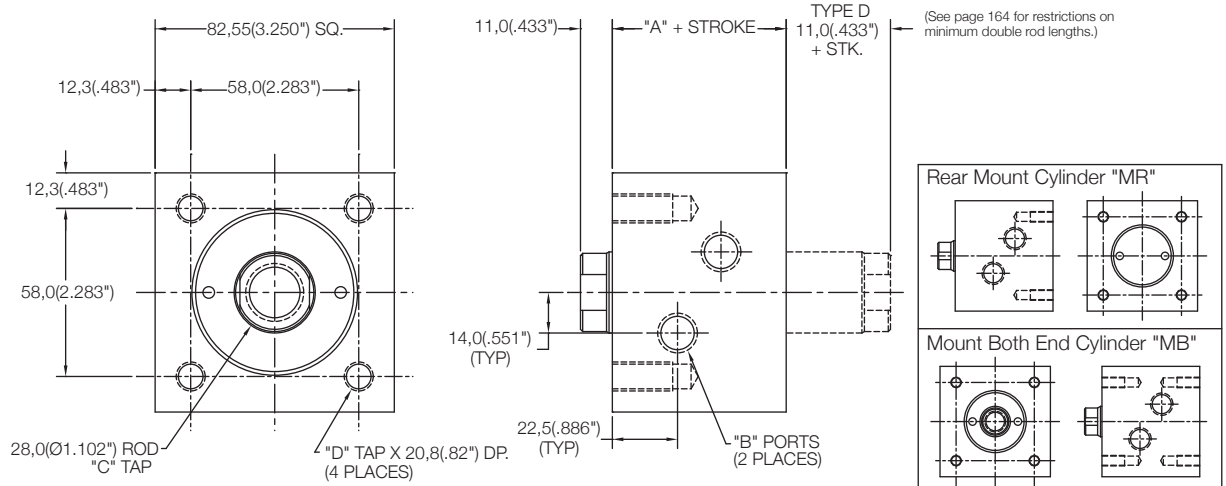

Thru Mount Cylinder "MT"

MODEL	TYPE	STANDARD STROKES	"A"	PISTON AREA
L30	_,D	25mm, 50mm, 75mm, 100mm	60,0(2.36")	PUSH 19,63 cm ² (3.04 in ²) PULL 13,48 cm ² (2.09 in ²)

	Standard Threads	"EM" Option
"B"	G1/4	#4 SAE
"C"	M20X2.5	3/4-16

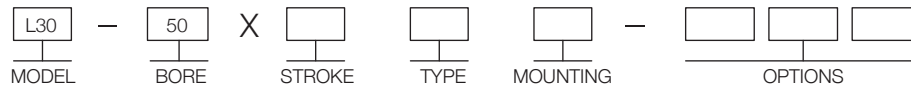
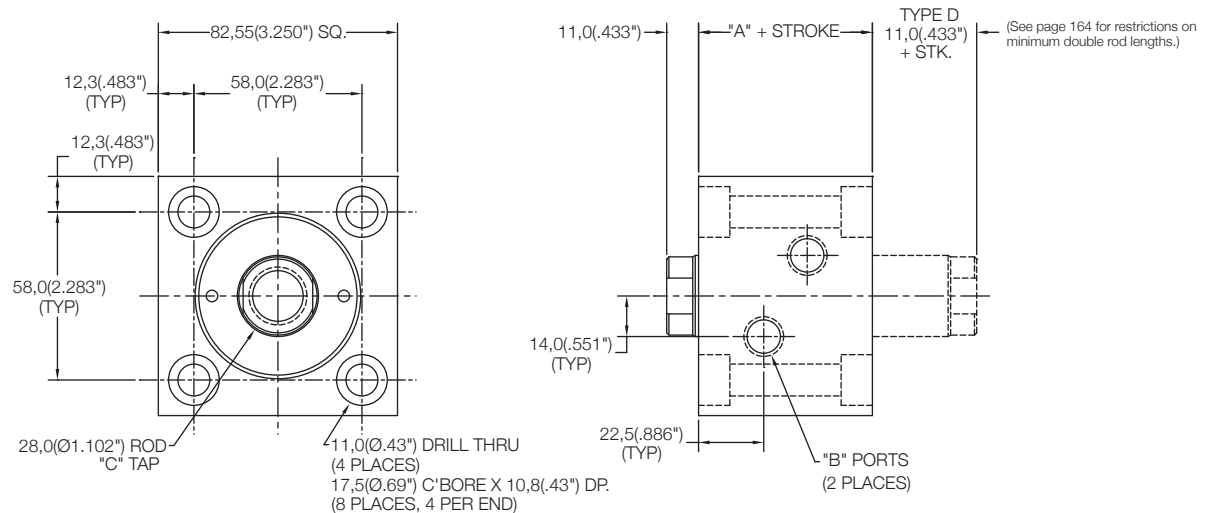

25mm, 50mm, 75mm, 100mm

BLANK - NO CODE, DOUBLE ACTING, SINGLE ROD
D - DOUBLE ACTING, DOUBLE ROD
(See page 164 for restrictions on minimum double rod lengths.)

MT - THRU MOUNT
MF - FRONT MOUNT
MR - REAR MOUNT
MB - BOTH MOUNT

EM - INCH THREADS & PORT OPTIONS
RM - ROD MALE THREADS
RF, RT, RN, RY, RV, RH - ROD EXTENSIONS (SEE PAGE 164)

Front Mount Cylinder "MF"

MODEL	TYPE	STANDARD STROKES	"A"	PISTON AREA
L30	_,D	25mm, 50mm, 75mm, 100mm	67,0(2.64")	PUSH 31,17 cm ² (4.83 in ²) PULL 20,99 cm ² (3.25 in ²)

	Standard Threads	"EM" Option
"B"	G1/4	#4 SAE
"C"	M27X3	1-14
"D"	M12X1.75	1/2-20

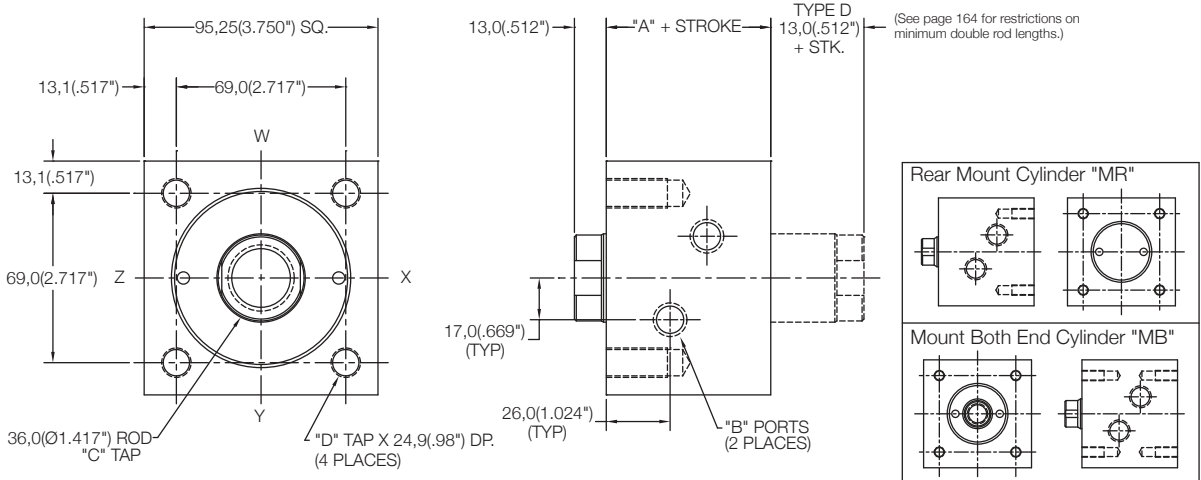

Thru Mount Cylinder "MT"

MODEL	TYPE	STANDARD STROKES	"A"	PISTON AREA
L30	_,D	25mm, 50mm, 75mm, 100mm	67,0(2.64")	PUSH 31,17 cm ² (4.83 in ²) PULL 20,99 cm ² (3.25 in ²)

	Standard Threads	"EM" Option
"B"	G1/4	#4 SAE
"C"	M27X3	1-14

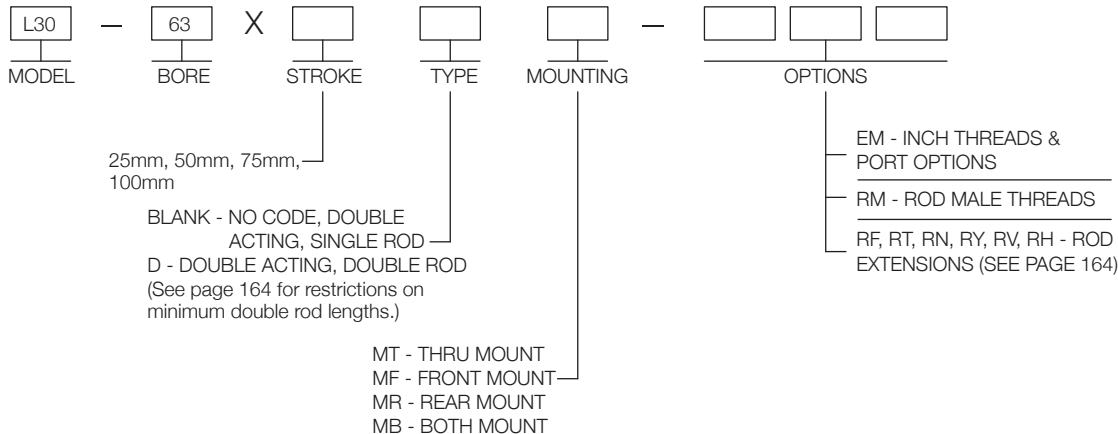
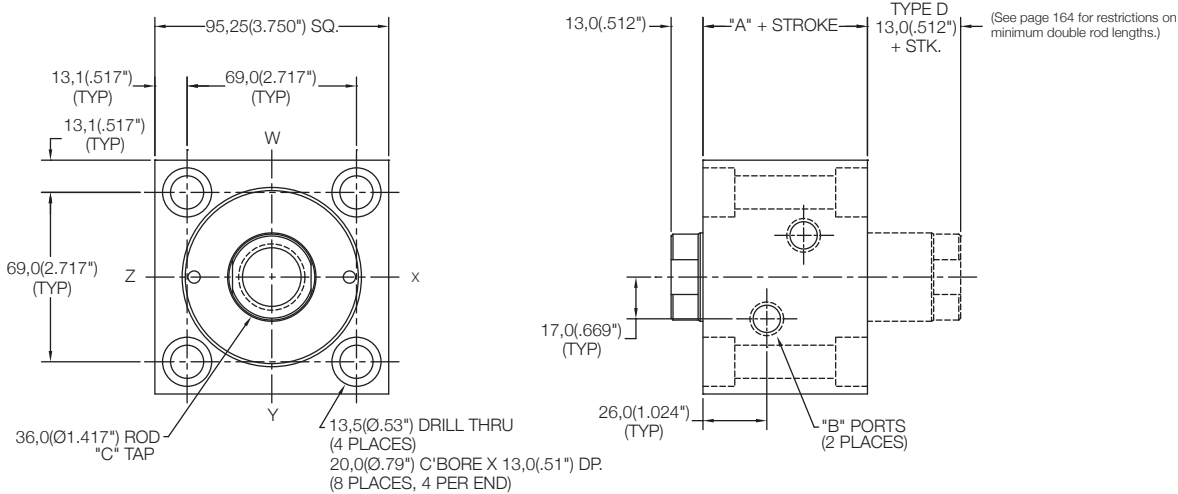

Front Mount Cylinder "MF"

MODEL	TYPE	STANDARD STROKES	"A"	PISTON AREA
L30	_D	25mm, 50mm, 75mm, 100mm	78,0(3.07")	PUSH 45,60 cm ² (7.07 in ²) PULL 29,70 cm ² (4.60 in ²)

	Standard Threads	"EM" Option
"B"	G3/8	#6 SAE
"C"	M33X3.5	1 1/4-12
"D"	M14X2	5/8-18

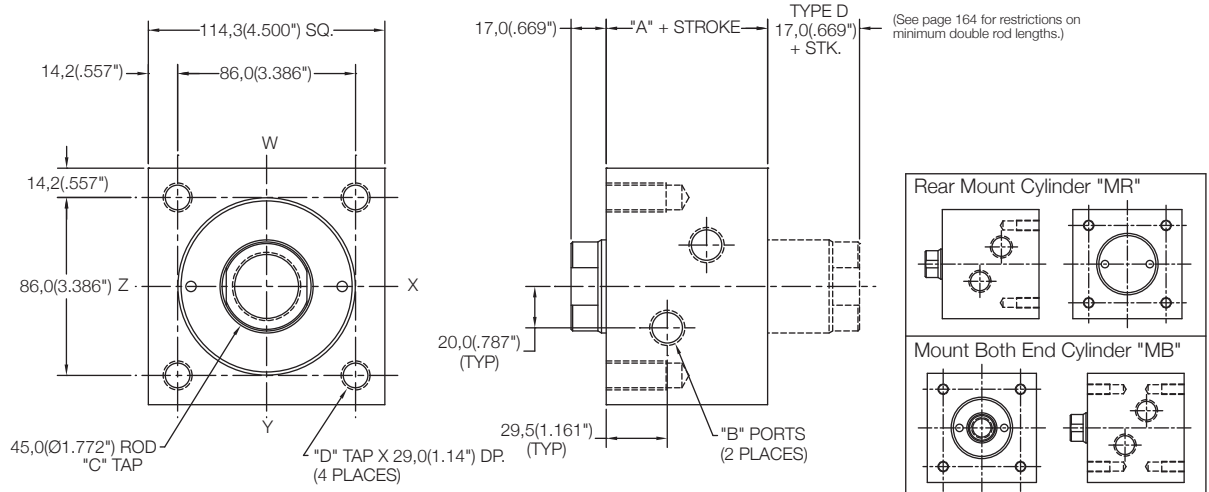

Thru Mount Cylinder "MT"

MODEL	TYPE	STANDARD STROKES	"A"	PISTON AREA
L30	_D	25mm, 50mm, 75mm, 100mm	78,0(3.07")	PUSH 45,60 cm ² (7.07 in ²) PULL 29,70 cm ² (4.60 in ²)

	Standard Threads	"EM" Option
"B"	G3/8	#6 SAE
"C"	M33X3.5	1 1/4-12

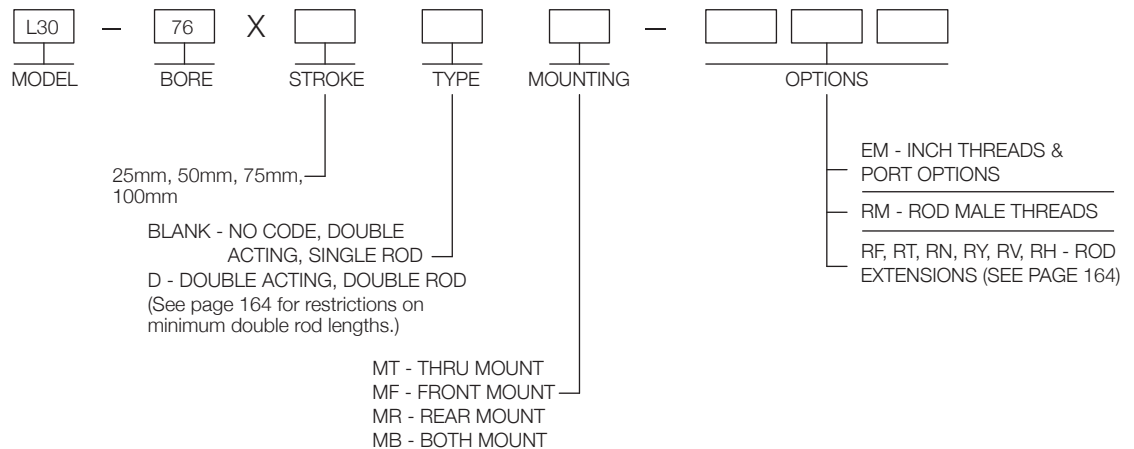
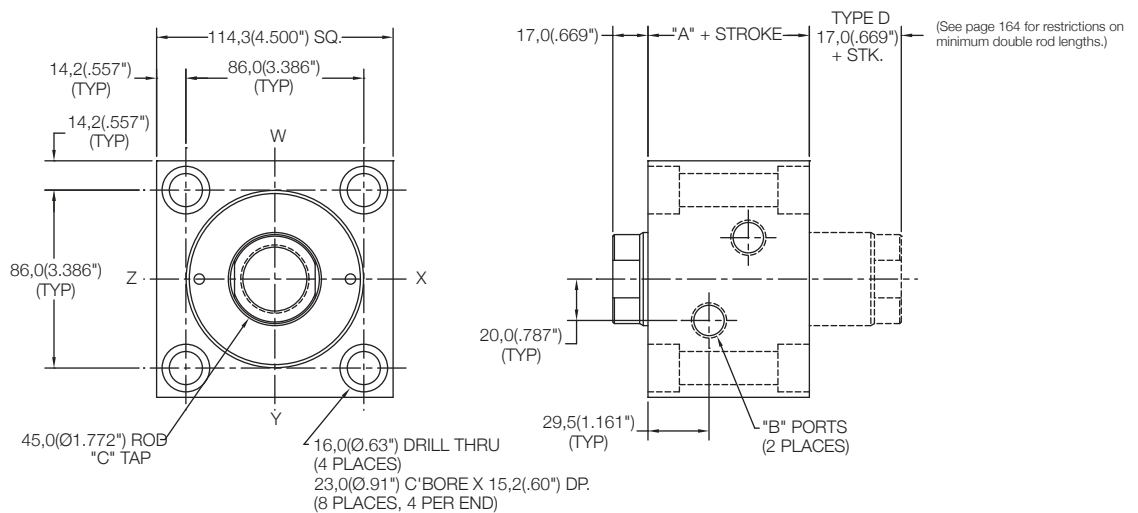

Male Thread Option - "RM"

Bore	"A"	"B"	"EM" Option	"B"
25	M10X1.25	16 (.63")	1/2-20	18 (.71")
32	M12X1.25	18 (.71")	9/16-18	25 (.98")
40	M16X1.5	22 (.87")	3/4-16	30 (1.18")
50	M20X1.5	28 (1.10")	7/8-14	35 (1.38")
63	M27X2	36 (1.42")	1 1/4-12	45 (1.77")
76	M33X2	45 (1.77")	1 1/2-12	56 (2.20")

Dimensions above are the same for double rod cylinders.

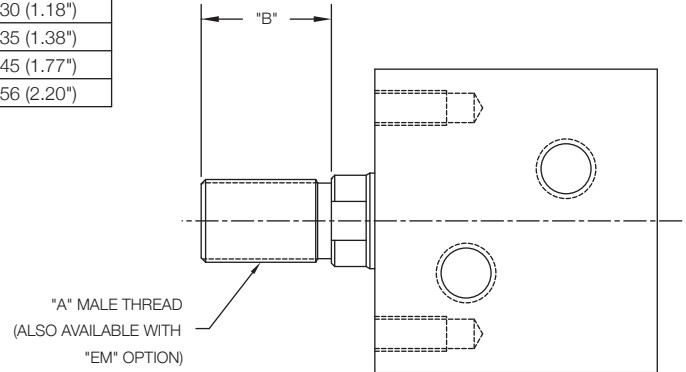

Rod End Detail See Chart Below

Bore	Ø"A"	"B"	"C"
25	13 (.51")	6 (.24")	12 (.47")
32	17 (.67")	8 (.31")	15 (.59")
40	21 (.83")	8 (.31")	19 (.75")
50	27 (1.06")	9 (.35")	24 (.94")
63	35 (1.38")	11 (.43")	32 (1.26")
76	43 (1.69")	13 (.51")	39 (1.54")

Dimensions above are the same for double rod cylinders.

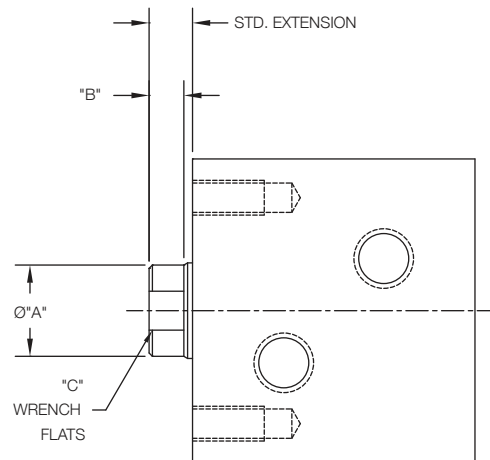

**Rod Extensions
Option - See Chart Below**

Extensions	"RF"	"RT"	"RN"	"RY"	"RV"	"RH"
Length	5 (.20")	10 (.39")	15 (.59")	20 (.79")	25 (.98")	35 (1.38")

For standard extension, see catalog pages.
If cylinder is double ended, extension will be on both ends.
Consult factory for single ended extension on a double ended cylinder.

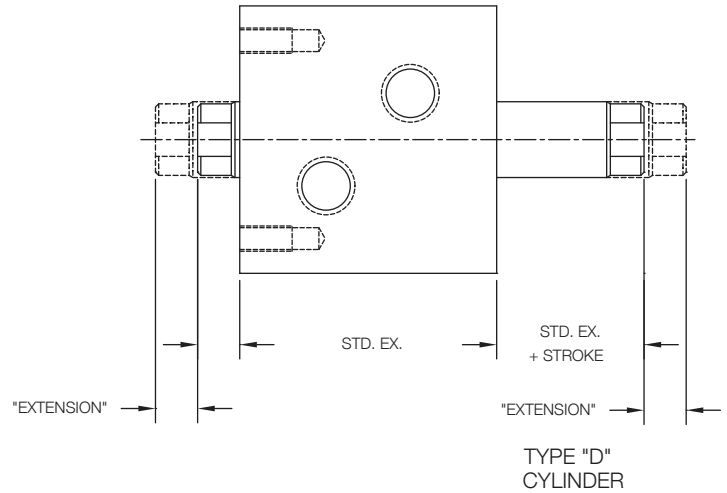

**Minimum Rod Extension for Double Rod
Option (Type "D") - See Chart Below**

Standard double rod cylinders must have "X" dimensions greater than or equal to those listed in the table below. Corresponding rod extensions will be added to cylinders which do not meet this minimum length, so that standard extension plus stroke adds up to "X" MIN. This applies only to rear rod.

Bore	STD. Ex.	"X" MIN	For Strokes Less Than
25	8 (.31")	23 (.91")	15 (.59")
32	10 (.39")	25 (.98")	15 (.59")
40	10 (.39")	30 (1.18")	20 (.79")
50	11 (.43")	31 (1.22")	20 (.79")
63	13 (.51")	38 (1.50")	25 (.98")
76	17 (.67")	42 (1.65")	25 (.98")

*Single rod cylinders and cylinders with "RM" rod male thread option do not have this restriction.

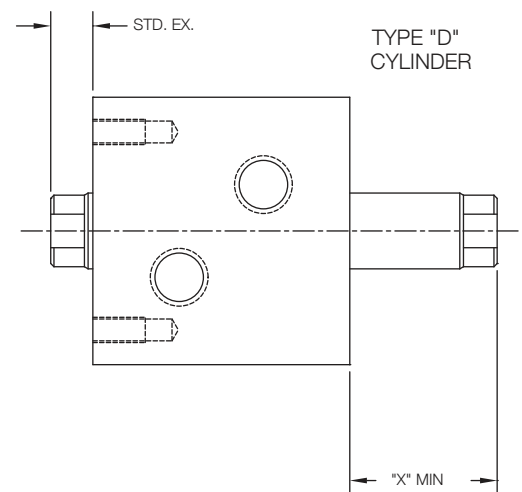

CUSTOM PRODUCTS

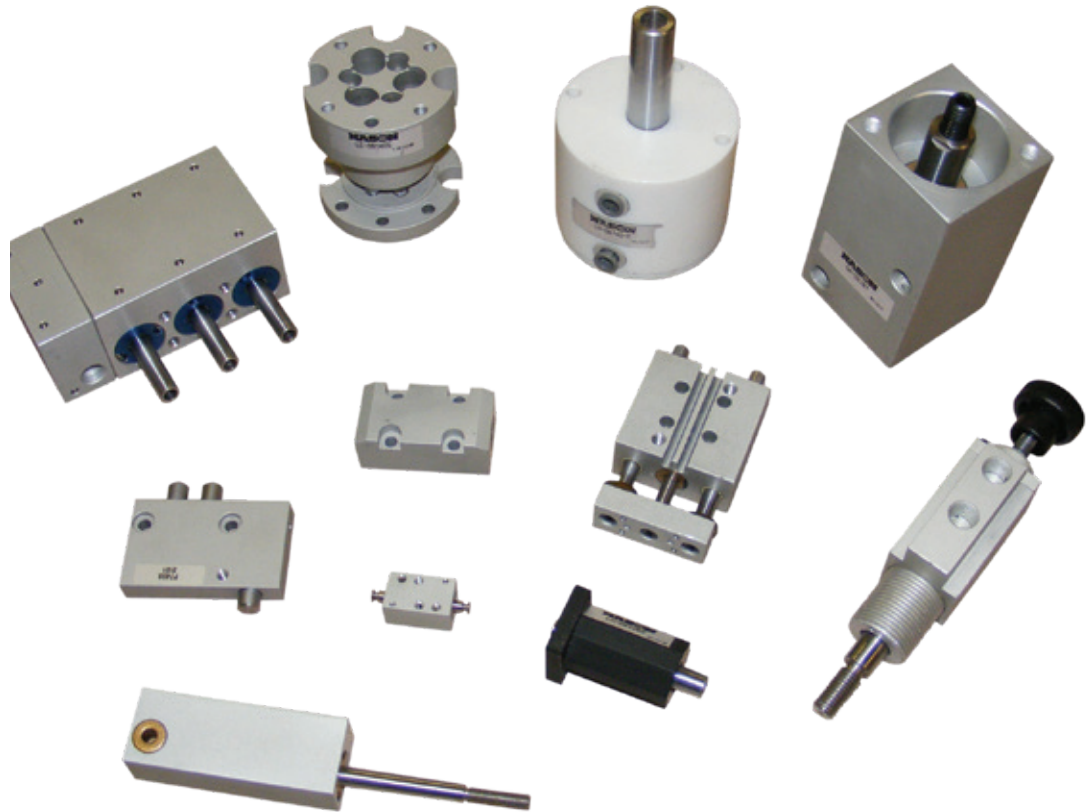

Engineered Solutions for Your Application

Stop working around everyone else's standard cylinder. Your machine is unique, so why not have Nason design a unique custom cylinder for your specific application? Just show us what you want and we can provide a prototype for your approval. On the following pages are some examples of solutions we have provided other customers. Each one was unique in its design parameters. Some are made from specific materials or have unique coatings for harsh or clean room environments; some are made for high output in a small package; and some are just plain unusual. Talk to Nason about your next design need, and you will be pleasantly surprised.



All stainless steel slide designed for heavy wash down application in the food packaging industry.



Powerful 1500 PSI hydraulic slide in a compact package.

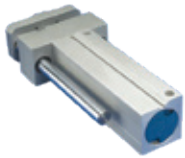

A low cost simple slide.



A heavy duty load carrying cylinder, made from plastic, for a highly corrosive environment.



Need a direct replacement of a competitor's product? Nason can help.



FOOD GRADE

Plastic cylinders up to 2 1/2" bore. Great for wash down environments.



ALL STEEL

Great for heavy duty applications. 3000 PSI hydraulic cylinders available in up to 3" bores.



HARD COAT ANODIZED WITH TEFLON

For those applications that require extremely low friction at very high speeds.



HARD COAT ANODIZING

We can hard coat anodize any aluminum cylinder manufactured by Nason to help prevent corrosion.



ALL STAINLESS STEEL

We can manufacture most of our product line out of 303 stainless steel.



Z COMPLIANCE

Special compliance devices that will meet your unique needs are available. When you can't find what you need in the marketplace just give us a call.



LOCKING CYLINDERS

Custom mechanical locking cylinders designed for a true locking application.



MULTI-BORE CYLINDERS

Multiple cylinders in a common housing. This allows for multiple cylinders to fit in tight spaces and hold tight tolerances.



VALVE MANIFOLD CYLINDER

With the valve mounting directly to the cylinder, response times are very quick.



ADJUSTABLE STROKE

Dial in your stroke with our adjustable extend stroke cylinder.



AIR TO OIL BOOSTER

From 4:1 intensification up to 50:1 and hydraulic outputs up to 5000 PSI.



ALSO AVAILABLE

**Our new, expanded
Nason switch catalog.**

SWITCHES

At Nason, we're serious about responding to our customers' exact requests. It's what sets us apart from the competition. That means our catalog is not just our product listing – it's our starting point for creating your ideal switch. We're proud to offer the industry's widest range of options, including set points, fluid and electrical connections, switch circuitry, current ratings, severe duty service and more. And our manufacturing strategy means we are able to deliver switches quickly and economically – even with prototype assignments. Because to us, it's not just custom work – it's customer service.

TRANSDUCERS

Our low-cost, high-value transducers are OEM tested and approved, featuring a number of innovative technologies, including a low current consumption design for our digital models. Our standard transducers come in compact, economical designs that are capable of accommodating a wide variety of ranges and outputs, depending on your specific application. Each one is highly accurate and available in four accuracy models, ensuring precise conversion regardless of harsh operating conditions. As always, you can count on Nason's in-house design and assembly process to ensure that your transducers can be processed and delivered quickly – often shipping within only 24 hours. Our experienced engineers are ready to help you find the transducer that will help you achieve your design goals.





CHECK OUT

nasonptc.com/configure
to create your own custom CAD file

WARRANTY:

It is the sole responsibility of the user to determine the suitability of any product or information supplied by Nason for any application or use by the user.

THE FOLLOWING IS IN LIEU OF ALL OTHER WARRANTIES, EXPRESS OR IMPLIED, INCLUDING THOSE OF MERCHANTABILITY AND FITNESS FOR A PARTICULAR PURPOSE.

The Nason Company warrants each product to be free from defects in material and workmanship under normal use and service. Nason's obligation under this warranty is limited to repairing or supplying, at our option, a part or parts to replace any defective part(s) within one (1) year from the date of original sale. Wear components including but not limited to seals, wear bands, and bearings are excluded from this warranty. No product will be returned without prior authorized approval. If authorized, the transportation charges are to be prepaid to The Nason Company, Walhalla, SC. Unauthorized returns will be returned freight collect. The provisions of this warranty will not apply to any part(s) which have been subject to misuse, negligence, or accident, or which have been repaired or altered outside of The Nason Company service department in any way so as in the judgement of Nason to adversely affect its performance, stability, or reliability. The Nason Company neither assumes nor authorizes anyone to assume for it any other obligation or liability for any loss or damage either direct, incidental or consequential resulting from or arising out of or in connection with any of its defective part(s). Nason will not be responsible for any labor or other charges in connection with the removal of a product deemed to be defective or for installation or replacement of a defective or repaired product. Buyer's sole remedies are as provided herein. In no event shall Nason be liable for any cost of Buyer's cover, or for any indirect, special, consequential, incidental, or punitive damages of any sort, whether based on tort or breach of contract and/or warranty.



Request Nason's catalog of custom engineered switches by calling toll free 800-229-4955 or visit our website at www.nasonptc.com

1307 S Highway 11 • Walhalla SC 29691
800.229.4955 • Phone: 864.638.9521
Fax: 864.638.7903 • Orders: 800.229.4955
www.nasonptc.com

SPINE