

Catalog HY08-SB1314-1NA  
August 2019

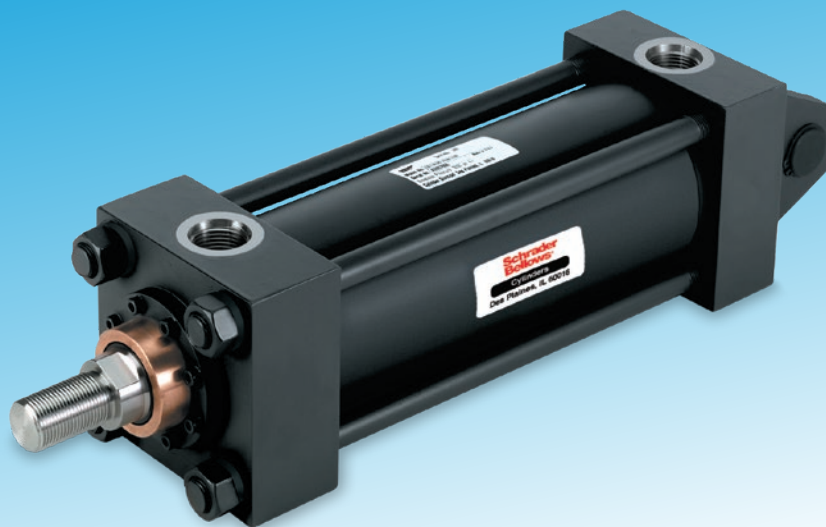

**Heavy Duty Service**

**Nominal Pressure – 3000 PSI**

**Available as Tie Rod Construction  
or Non-Tie Rod Construction**

**Standard Bore Sizes –  
1.50" through 20.00"**

# Schrader Bellows®

Abrasive particulate can cause significant wear to precision components when it enters the cylinder and migrates into the hydraulic system. The Schrader Bellows Crown Wiper is extremely effective in keeping contamination out of the cylinder to prevent it from shortening the actuator and system service life. Schrader Bellows showcases its commitment to reducing hydraulic system problems with the Crown Wiper. This innovative solution goes a long way toward improving equipment operation, lowering costs, extending component life and machine availability.

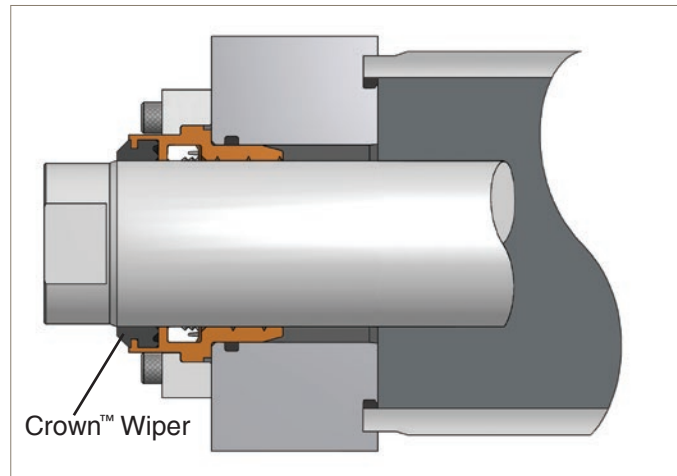

## Product Features:

- The sharp leading edge cleans the piston rod on the retract stroke.
- The Crown Wiper acts as a secondary seal by wiping away any oil film adhering to it on the extended stroke.
- Durable polyurethane material works well for both Seal Class 1 and 4 Service.
- Available in fluorocarbon material for Class 5 service in elevated temperatures.
- Beveled design sheds abrasive contamination away from the bushing.
- Available in rod diameters 0.625" - 5.500".
- Does not change cylinder mounting dimensions.

In line with our policy of continuing product improvement, specifications and information contained in this catalog are subject to change.  
Copyright ©2019 by Parker Hannifin Corporation. All rights reserved.  
PRINTED IN THE U.S.A.

### WARNING

**FAILURE OR IMPROPER SELECTION OR IMPROPER USE OF THE PRODUCTS AND/OR SYSTEMS DESCRIBED HEREIN OR RELATED ITEMS CAN CAUSE DEATH, PERSONAL INJURY AND PROPERTY DAMAGE.**

This document and other information from the Parker Hannifin Corporation, its subsidiaries and authorized distributors provide product and/or system options for further investigation by users having expertise. It is important that you analyze all aspects of your application, including consequences of any failure and review the information concerning the product or system in the current product catalog. Due to the variety of operating conditions and applications for these products or systems, the user, through its own analysis and testing, is solely responsible for making the final selection of the products and systems and assuring that all performance, safety and warning requirements of the application are met.

The products described herein, including without limitation, product features, specifications, designs, availability and pricing, are subject to change by Parker Hannifin Corporation and its subsidiaries at any time without notice.

### Offer of Sale

The items described in this document are hereby offered for sale by Parker Hannifin Corporation, its subsidiaries or its authorized distributors. This offer and its acceptance are governed by provisions stated on a separate page of the document entitled 'Offer of Sale'.

### PROP 65 WARNING

**Warning:** This product can expose you to chemicals including **Lead and Lead Compounds** which are known to the State of California to cause cancer and birth defects or other reproductive harm. For more information go to [www.P65Warnings.ca.gov](http://www.P65Warnings.ca.gov)

# Table of Contents

## Newest Design Features of the PH Series Cylinder pages II-IV

### Overview – PH Series pages 1-8

Features and Benefits . . . . .	2-3	Model Code / How To Order . . . . .	6-7
Application Checklist . . . . .	4	Piston Seal Options . . . . .	8
Mounting Styles & Tips for Applying Them. . . . .	5		

**A**  
Overview

### PH Series 1.50" - 8.00" Bore pages 11-45

PH 1.50" - 8.00" Bore Specifications / Mounting Styles . . . . .	11	PH 7.00" & 8.00" Bore Rod End Styles and Dimensions. . . . .	31
PH 1.50" - 6.00" Bore Rod End Styles and Dimensions . . . . .	12-13	PH 7.00" & 8.00" Bore Mount Dimensions . . . . .	32-44
PH 1.50" - 6.00" Bore Mounting Information . . . . .	14-29	PH 7.00" & 8.00" Bore Double Rod Models . . . . .	45
PH 1.50" - 6.00" Bore Double Rod Cylinders . . . . .	30		

**B**  
PH Series  
1.50" - 8.00" Bore

### PH Series 10.00" - 20.00" Bore pages 48-66

PH 10.00" - 20.00" Bore Performance . . . . .	48	PH 10.00" - 20.00" Bore Specifications / Mountings . . . . .	54
PH 10.00" - 20.00" Bore Construction . . . . .	49	PH 10.00" - 20.00" Bore Rod End Styles and Dimensions . . . . .	55
Model Code / How To Order . . . . .	50-51	PH 10.00" - 20.00" Bore Mount Dimensions . . . . .	56-65
PH 10.00" - 20.00" Bore Piston Seal Options. . . . .	52	PH 10.00" - 20.00" Bore Double Rod Models . . . . .	66
PH Large Bore Hybrid Composite Bushing . . . . .	53		

**C**  
PH Series  
10.00" - 20.00" Bore

### Cylinder Accessories and Replacement Parts pages 67-83

Mounting Accessories . . . . .	68-71	Linear Alignment Coupler, Split Coupler and Weld Plates. . . . .	74-75
Style SB & SE Spherical Bearing Mounting Accessories . . . . .	72-73	PH Parts Identification, Torque, Rod Gland, Rod Seal, Piston Seal and Body Seal Kits . . . . .	76-83

**D**  
Accessories / Parts

### Custom Modifications pages 85-98

Magnetic Piston, Magnetic Switch Choices . . . . .	86-87	Metallic Rod Scraper, Crown Wiper, Rod End Boots, Gland Drain and Air Bleeds . . . . .	96
End-of-Stroke Proximity Switches. . . . .	88-91	Tie Rod Supports, Stroke Adjusters, Thrust Key Mountings, and Metric Piston Rod Thread. . . . .	97
Water Submersible Option and How to Order . . . . .	92-93	Global Shield™ Rod Coating . . . . .	98
Buffer Seal Gland, Rod End Styles and Gland Seal Kits. . . . .	94-95		

**E**  
Custom Modifications

### Engineering Data pages 99-120

Push Pull Forces . . . . .	100-101	Ports . . . . .	108-109
Cylinder Weights . . . . .	103	Stroke Data / Mounting Groups. . . . .	110
Operating Fluids and Seals / Temperature Range. . . . .	104	Stop Tubing. . . . .	111
Fluids and Temperature Range / Pressure Rating. . . . .	105	Piston Rod Selection Data. . . . .	112-113
Piston & Bushing Friction / Piston Orifice . . . . .	106-107	Cushioning . . . . .	115-120

**F**  
Engineering Data

Cylinder Safety Guide . . . . .	124-125
Offer of Sale . . . . .	126

**⚠ PROP 65 WARNING** **WARNING:** This product can expose you to chemicals including **Lead and Lead Compounds** which are known to the State of California to cause cancer and birth defects or other reproductive harm. For more information go to [www.P65Warnings.ca.gov](http://www.P65Warnings.ca.gov)

## Piston Sealing Solutions for the Most Demanding Applications

### Piston Seal Technology For The 21st Century

The new Schrader Bellows universal piston seal design addresses the performance balance between low pressure sealability, low friction, extrusion resistance and seal life.

One piston style is used for all piston seal and wear ring configurations and will suit all application requirements. A common piston design permits field changing of seal configuration or seal and wear band material without replacing costly machined components when variations in application parameters occur, such as fluid, temperature or duty cycle.

All piston options include dual non-metallic wear rings to provide maximum stability and bearing area for protection against eccentric loads.

WearGard™ wear rings are internally lubricated for reduced friction and formulated for heavy-duty load-bearing applications.

The standard piston style for Class 1 and 4 service is HP; for 2, 3, 5, 6 and 8 service the standard is KP. If a different piston style is desired for an eligible seal class, enter an 'S' in the Special Modification field of the model number and specify the piston style in text.

#### Schrader Bellows HP Polyurethane Piston Seal

#### Schrader Bellows KP Filled PTFE Piston Seal

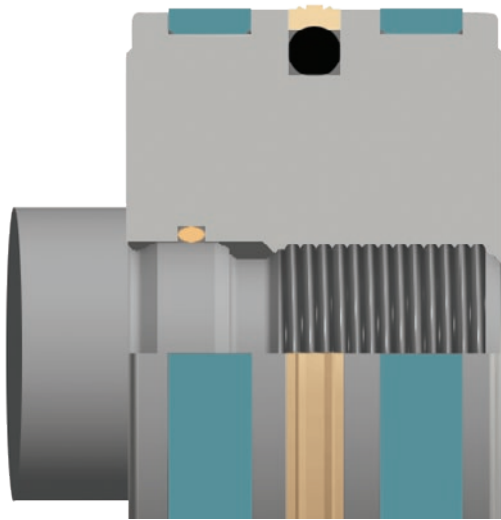

The Schrader Bellows HP energized bi-directional piston seal improves upon the low friction and long wear of lipseals by including excellent low pressure sealing performance. Specially formulated polyurethane is long wearing and abrasion resistant with running friction comparable to lipseals. An o-ring energizer ensures virtually zero leakage in low pressure applications. Also, pressure trapping that can result with energized lipseals is not possible with a single energized seal.

The Schrader Bellows HP piston seal is an excellent choice for most industrial applications operating with mineral based hydraulic oil and is available in Seal Classes 1 and 4.

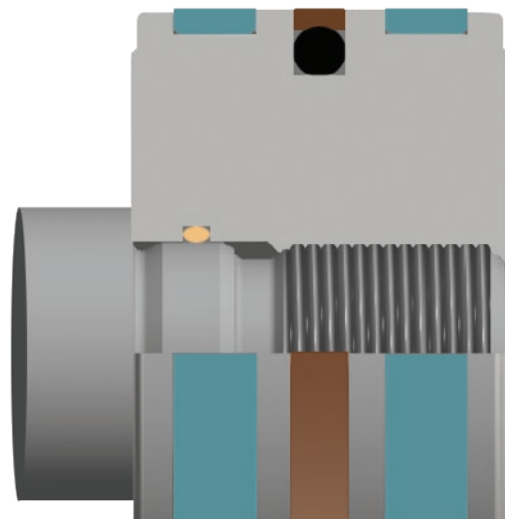

The Schrader Bellows KP bronze filled PTFE seal ring material has low running friction for accurate positioning in closed loop servo applications.

When combined with a fluorocarbon energizing ring the Schrader Bellows KP seal is rated for 400° F and will increase service intervals in high temperature applications even when compared to fluorocarbon lipseals.

By combining the Schrader Bellows KP seal with other energizer o-ring compounds and wear ring materials, the KP seal offers excellent service in all Seal Class environments.



**PROP 65 WARNING**

**WARNING:** This product can expose you to chemicals including **Lead and Lead Compounds** which are known to the State of California to cause cancer and birth defects or other reproductive harm. For more information go to [www.P65Warnings.ca.gov](http://www.P65Warnings.ca.gov)

**Selection Guide**

Application Demand	HP Seal	KP Seal	RP Seal	WP Seal
Load Holding	Best	Good	Good	Best
Fluid Compatibility	Good	Best	Better	Better
Heat Resistance	Good (200° F Max.)	Best (400° F Max.)	Better (300° F Max.)	Better (250° F Max.)
Dynamic Friction	Best	Best	Good	Better
Breakaway Friction	Good	Best	Good	Better
Extrusion Resistance	Good	Better	Best	Good
Fluid Isolation	N/A	N/A	N/A	Best

**Schrader Bellows RP Thermoplastic Seal**

**Schrader Bellows WP Mixed Media Seal**

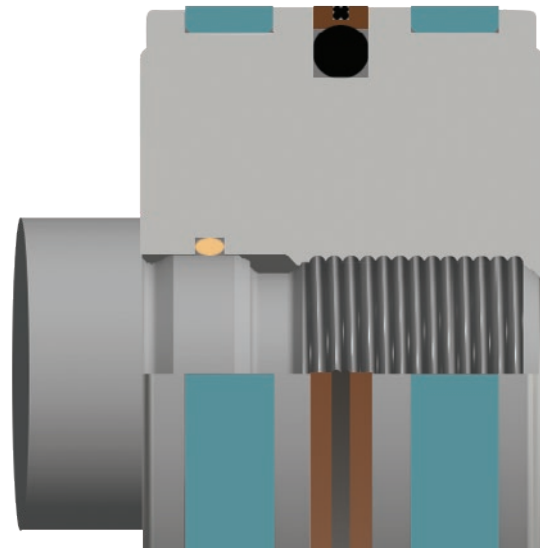
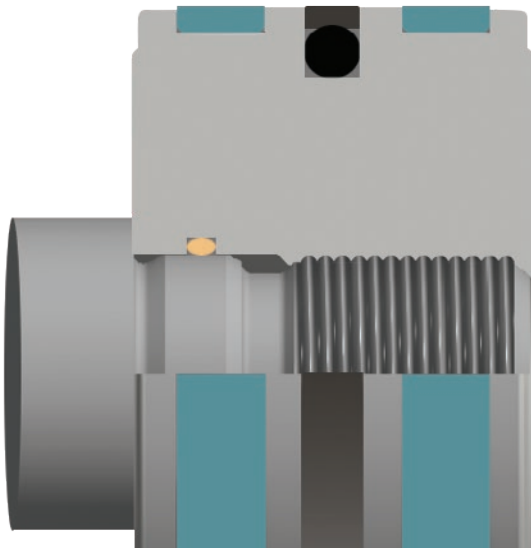

The Schrader Bellows RP step cut ring is made of self-lubricating, glass reinforced, thermoplastic and is o-ring energized. Unlike cast iron rings that bypass oil, the Schrader Bellows RP seal provides drift free operation throughout the operating pressure range. This tough seal is fully extrusion resistant, even in the face of extreme pressure spikes, thus ensuring superior wear resistance in the most demanding applications.

Schrader Bellows RP can operate up to 300° F and is compatible with Seal Classes 1, 2, 3, 4, 5 and 6.

The Schrader Bellows WP Mixed Media seal is designed for applications requiring different media on either side of the piston. This option is ideal when hydraulic oil is on one side of the piston and air is on the opposite side; and it can be equally effective when dissimilar fluids are on either side of the piston.

Superior low-friction bi-directional sealing is accomplished by combining an energized filled PTFE seal with a redundant elastomer seal. Energizer and redundant elastomer seal materials are available for compatibility with seal classes 1, 2, 3, 5 and 6. Note: WP piston seal groove is not universal in 1.50" bore.

**⚠ PROP 65 WARNING** WARNING: This product can expose you to chemicals including **Lead and Lead Compounds** which are known to the State of California to cause cancer and birth defects or other reproductive harm. For more information go to [www.P65Warnings.ca.gov](http://www.P65Warnings.ca.gov)

## **Versatile Piston Rod Sealing Systems Deliver Dry Rod Performance**

Schrader Bellows offers the best performing and broadest selection of rod sealing options. Our Tri-lip bolted bushing sealing system is a proven anchor of the offering.

As the rod strokes out, its motion and friction dynamically flex the multi-sealing edges of the Tri-Lip rod seal to maintain their contact with the rod. This provides a cutting action to shear the oil from the rod, allowing the rod to pass out of the rod seal practically dry. Any oil film that remains on the rod is stopped by the inner lip of the Wiperseal and held between it and the rod seal.

On the return stroke any dirt or foreign matter collected on the

rod is wiped off by the leading edge, or outer lip of the Wiperseal. At the same time, any oil which may be trapped between the Wiperseal and the rod seal is returned into the cylinder. In other words, we have an automatic check valve that prevents any appreciable amount of oil to leak past the seals, and then returns any oil that has managed to wipe by the rod seal.

Tri-Lip bushings are easily removed for service without loosening tie rods and disturbing the pressure envelope. Material options allow compatibility with Seal Classes 1, 2, 3, 4, 5 & 6.

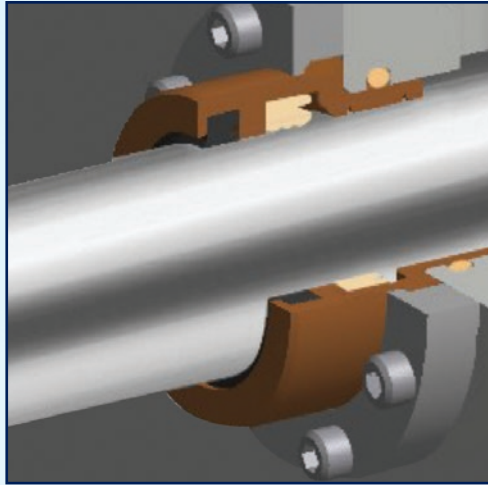

### **Buffer Seal Bushing**

The Schrader Bellows Buffer Seal, installed ahead of the primary rod seal, protects the primary seal from the effects of pressure spikes. The result is increased primary rod seal and wiperseal performance life when in severe applications.

The Schrader Bellows Buffer Seal is a unique design that allows trapped pressure back into the cylinder. When

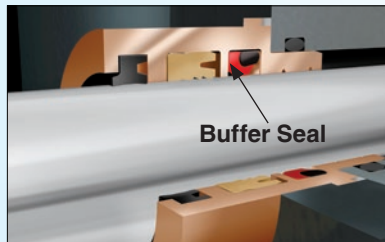

the rod extends from the cylinder the Buffer Seal is riding on a high compression sealing point to limit leakage. On the retract stroke the seal rocks forward to allow trapped fluid to pass under the seal and return to the system.

Buffer Seals are available with Seal Classes 1, 2, 4 & 5. To order, enter an 'S' in the Special Modification field of the model number and specify Buffer Seal

To accommodate the Buffer Seal, rod bushing length is extended 0.31" to 0.81", depending on rod diameter. See Buffer Seal Bushing page 61 for piston rod extension details.

### **Low Friction Bushing**

The Schrader Bellows Low Friction Bushing is designed to minimize 'slip-stick' and 'chatter' in servo and 'dither' applications. Two unidirectional bronze filled PTFE primary rod seals and a bronze filled PTFE wiperseal minimize both breakaway and running friction.

Low Friction Rod Seals are available for rod diameters 1.000" - 5.500" in 1.50" - 8.00" bores.

See Piston & Bushing Friction page for comparative seal friction data.

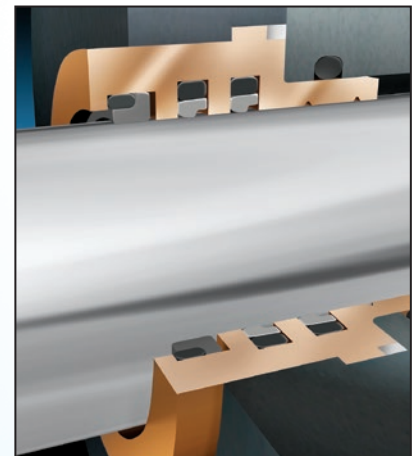

To order, enter an 'S' in the Special Modification field of the model number and specify Low Friction Bushing. Available with Seal Classes 1, 2, 3, 4, 5, 6 & 8.



**PROP 65 WARNING**

**WARNING:** This product can expose you to chemicals including **Lead and Lead Compounds** which are known to the State of California to cause cancer and birth defects or other reproductive harm. For more information go to [www.P65Warnings.ca.gov](http://www.P65Warnings.ca.gov)

## Section A

### Series PH Heavy Duty Hydraulic Cylinders

Features and Benefits	2-3
Application Checklist	4
Mounting Styles & Tips for Applying Them	5
PH Family Model Code / How To Order	6-7
Piston Seal Options	8

 **PROP 65 WARNING** WARNING: This product can expose you to chemicals including **Lead and Lead Compounds** which are known to the State of California to cause cancer and birth defects or other reproductive harm. For more information go to [www.P65Warnings.ca.gov](http://www.P65Warnings.ca.gov)

# The inside story on why PH Series is your best choice in heavy duty hydraulic cylinders

Overview  
**A**

**Primary Seal** – Tri-lip Rod Seal is a proven leakproof design – completely self-compensating and self-relieving to withstand variations and conform to mechanical deflection that may occur.

**Secondary Seal** – Double-Service urethane Wiperseal™ wipes clean any oil film adhering to the rod on the extend stroke and cleans the rod on the return stroke.

**Rod Bushing Assembly** – Externally removable without cylinder disassembly. Long bearing surface is inboard of the seals, assuring positive lubrication from within the cylinder. An o-ring is used as a seal between bushing and head.

**Piston Rod Thread** – Male rod end styles #4A and #8A are integral cut threads on the piston rod. Optional studded KK small male thread, for piston rod diameters 2.000" and smaller, is available by specifying rod end style 4H.

**Piston Rod** – Medium carbon steel, induction case-hardened, hard chrome-plated and polished to 10 RMS finish. Piston rods are made from 85,000 to 100,000 psi minimum yield material in .625" through 4.000" diameters. Larger diameters vary between 57,000 and 90,000 psi minimum material, depending on rod diameter.

**Ports** – SAE "O" ring ports are standard.

**Optional Ports** – NPTF ports are optional at no extra charge. Oversize NPTF and SAE ports are available at extra charge.

**Hardened Steel Washers** – Insure accurate Tie Rod Prestress

**Align-A-Groove** – A  $\frac{3}{16}$ " wide surface machined at each end of the cylinder body. Makes precise mounting quick and easy.

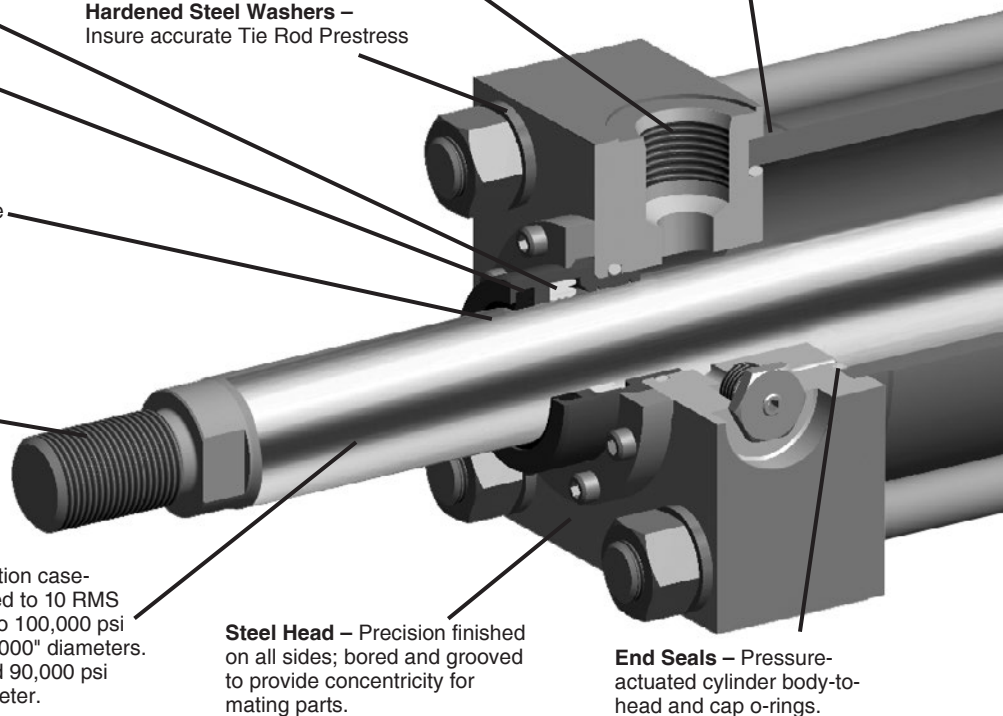

**Steel Head** – Precision finished on all sides; bored and grooved to provide concentricity for mating parts.

**End Seals** – Pressure-actuated cylinder body-to-head and cap o-rings.

## Schrader Bellows' stepped floating cushions combine the best features of known cushion technology.

Deceleration devices or built-in "cushions" are optional and can be supplied at head end, cap end, or both ends without change in envelope or mounting dimensions. Schrader Bellows cylinder cushions are a stepped design and combine the best features of known cushion technology.

Standard straight or tapered cushions have been used in industrial cylinders over a very broad range of applications. Schrader Bellows research has found that both designs have their limitations.

As a result, Schrader Bellows has taken a new approach in cushioning of industrial hydraulic cylinders and for specific load and velocity conditions have been able to obtain deceleration curves that come very close to the ideal. The success lies in a stepped sleeve or spear concept where the steps are calculated to approximate theoretical orifice area curves.

In the cushion performance chart, pressure traces show the results of typical orifice flow conditions. Tests of a three-step sleeve or spear show three pressure pulses coinciding with the

steps. The deceleration cushion plunger curves shape comes very close to being theoretical, with the exception of the last  $\frac{1}{2}$  inch of travel. This is a constant shape in order to have some flexibility in application. The stepped cushion design shows reduced pressure peaks for most load and speed conditions, with comparable reduction of objectionable stopping forces being transmitted to the load and the support structure.

All Schrader Bellows PH cushions are adjustable.

The PH Series cylinder design incorporates the longest cushion sleeve and cushion spear that can be provided in the standard envelope without decreasing the rod bearing and piston bearing strengths.

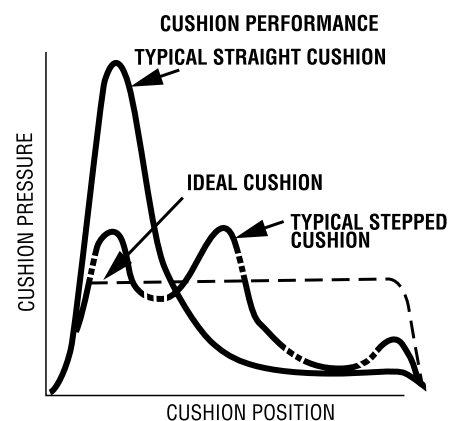

**⚠ PROP 65 WARNING** WARNING: This product can expose you to chemicals including **Lead and Lead Compounds** which are known to the State of California to cause cancer and birth defects or other reproductive harm. For more information go to [www.P65Warnings.ca.gov](http://www.P65Warnings.ca.gov)



**Adjustable Floating Stepped Cushions** – For maximum performance – economical and flexible for even the most demanding applications – provides superior performance in reducing shock. Cushions are optional and can be supplied at head end, cap end, or both ends without change in envelope or mounting dimensions.

**Steel Cap** – Precision finished on all sides; bored and grooved to provide concentricity for mating parts.

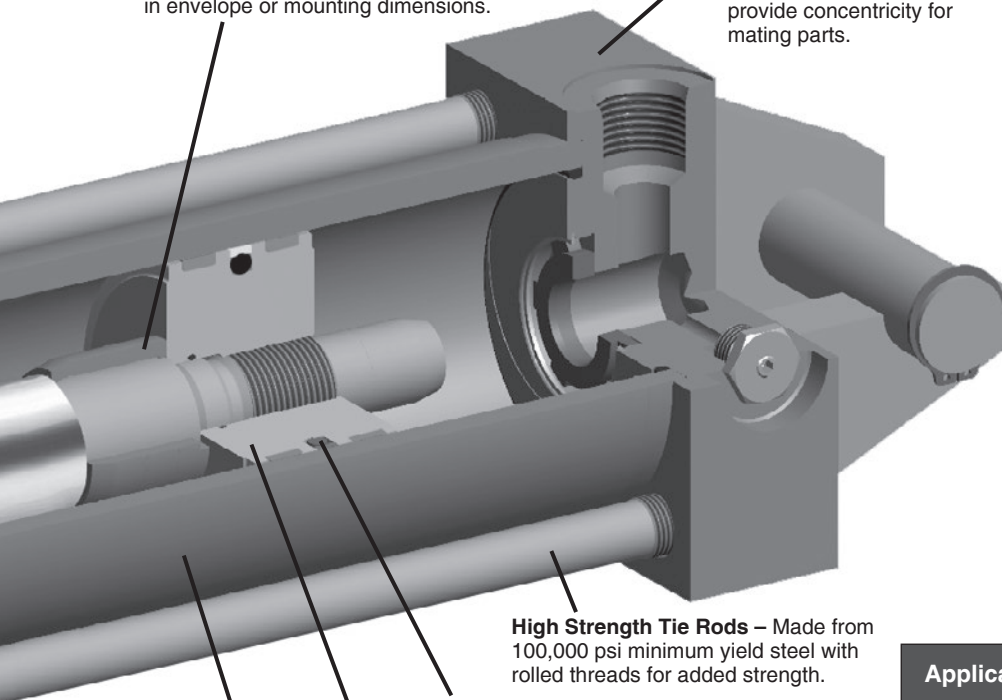

**Cylinder Body** – Heavy-wall steel tubing, honed to a micro finish bore.

**High Strength Tie Rods** – Made from 100,000 psi minimum yield steel with rolled threads for added strength.

**Problem Solving Piston Seal Options** – Schrader Bellows's new piston seal designs address the performance balance between low pressure seal ability, low friction, extrusion resistance and seal life.

**One-Piece Nodular Iron Piston** – Two non-metallic wear bands that minimize tube scoring are standard with all seal styles. Piston to rod connection is pre-stressed to maximize fatigue life. An o-ring on the piston ID ensures a leak free joint and anaerobic adhesive further secures the threaded connection.

**One Common Piston for 4 Seal Styles**

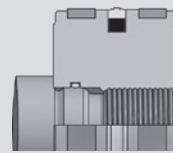

**Standard HP style** with polyurethane piston seal – excellent for most cycling and load holding applications.

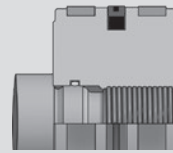

**Optional KP style** with filled PTFE piston seal – low friction, high heat resistance for cycling and load holding service.

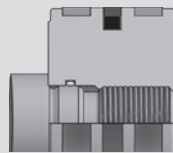

**Optional RP style** with thermoplastic piston seal – superior extrusion resistance to extreme pressure spikes with drift-free performance.

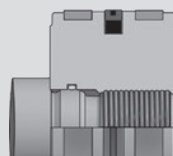

**Optional WP style** mixed media piston seal – low friction primary seal with redundant elastomer delivers superior performance with dissimilar media on either side of the piston.

Application Demand	HP Seal	KP Seal	RP Seal	WP Seal
<b>Load Holding</b>	Best	Good	Good	Best
<b>Fluid Compatibility</b>	Good	Best	Better	Better
<b>Heat Resistance</b>	Good	Best	Better	Better
<b>Dynamic Friction</b>	Best	Best	Good	Better
<b>Breakaway Friction</b>	Good	Best	Good	Better
<b>Extrusion Resistance</b>	Good	Better	Best	Good
<b>Fluid Isolation</b>	N/A	N/A	N/A	Best

- (1) When a cushion is specified at the head end:
- A self-centering stepped sleeve is furnished on the piston rod assembly.
  - A cartridge style needle valve is provided that is flush with the side of the head even when wide open. It is located on side number 2, in all mounting style models except ME5, ME6, MT1, MT2, MT4 and MT5. In these styles it is located on side number 3.
  - All cylinder bores utilize a slotted sleeve as a check valve.

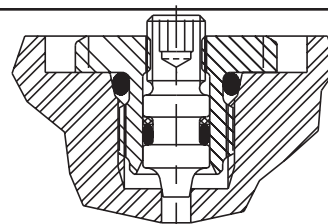

**Cartridge Style Needle Valve**

- (2) When a cushion is specified at the cap end:
- A stepped cushion spear is provided on the piston rod.
  - A "float check" self-centering bushing is provided in 1.50" - 6.00" bore cylinders, which incorporates a large flow check valve for fast "out-stroke" action. 7.00" bore and larger cylinders utilize a springless check valve located and identified in the same manner as the head end.
  - A cartridge style needle valve is provided that is flush with the side of the cap when wide open. It is located on side number 2 in all models except ME5, ME6, MT1, MT2, MT4 and MT5. In these styles it is located on side number 3.

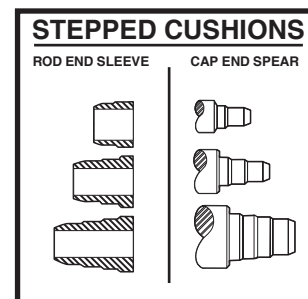

**⚠ PROP 65 WARNING** **WARNING:** This product can expose you to chemicals including **Lead and Lead Compounds** which are known to the State of California to cause cancer and birth defects or other reproductive harm. For more information go to [www.P65Warnings.ca.gov](http://www.P65Warnings.ca.gov)

# Application Checklist

The following checklist should be used to select the best possible cylinder for a given application. Additional information can be referenced in the following pages to help assist in this process. In the event that you have additional questions or concerns, or if more information is required, please contact your local Schrader Bellows distributor or our customer service representatives for assistance.

1. **Establish the system requirements** ..... Series PH
  - How heavy is the load to be moved?
  - What is the nominal operating pressure of the system?
  - How far does the load have to move?
  - What is the speed at which the load will move?
  - What is the fluid type and the temperature to which the cylinder will be exposed?
2. **Mounting Style** ..... Pages 5 & 54
  - Determine the best mounting style for the application.
  - If your application requires a mounting style that is not exactly matched by one of our catalog offerings, we can supply the mounting you need. If the required mounting resembles one of our standards, specify that style, enter 'S' in the Special Modification field and provide a dimension drawing of your mount. Special mounting styles that do not resemble a standard style will be designated as style TX by the factory.
3. **Cylinder Bore and Operating Pressure** ..... Pages 100-101
  - Review the theoretical push and pull force for a given bore size to determine.
4. **Piston Rod** ..... Pages 112-114
  - Determine what rod size will be required to avoid buckling.
  - Determine if a single or double rod cylinder is required.
  - Determine the rod end style and rod end thread.
  - Will stop tubing be required?
5. **Piston Seals** ..... Pages II and III
  - Determine the best seal type for your application. All selections are high load style that include dual non-metallic wear bands straddling the piston seal.
  - **Schrader Bellows HP** polyurethane piston seal can hold a load in position and is your best choice for general industrial applications utilizing mineral based fluids in Seal Classes 1 & 4.
  - **Schrader Bellows KP** filled PTFE piston seal is our lowest friction and highest heat resistance (up to 400° F) offering that will hold a load in position and can withstand high load and is available in all Seal Classes.
  - **Schrader Bellows RP** self-lubricating, reinforced, heat-stabilized thermoplastic piston seal has the highest resistance to extrusion in extreme pressure spike conditions, can hold a load in position and has long wear characteristics comparable to cast iron rings. RP seals are available in Seal Classes 1, 2, 3, 4 and 6.
  - **Schrader Bellows WP** mixed-media piston seal is for applications requiring different media on either side of the piston and is ideal with hydraulic fluid on one side of the piston and compressed air on the opposite side. WP seals are available in Seal Classes 1, 2, 3, 5 and 6.
6. **Cushioning** ..... Pages 115-120
  - Determine if cushions are required to safely stop the load.
  - Determine whether optional solid cap cushion construction should be selected over standard floating cushion bushing style.
7. **Ports** ..... Pages 108-109
  - Select the best possible port size for a given speed requirement.
  - Select port position.
8. **Piston rod and mounting accessories** ..... Pages 68-75
  - Determine how you will attach the cylinder to the load.
9. **Custom modifications** ..... Pages 86-98



**⚠ PROP 65 WARNING** WARNING: This product can expose you to chemicals including **Lead and Lead Compounds** which are known to the State of California to cause cancer and birth defects or other reproductive harm. For more information go to [www.P65Warnings.ca.gov](http://www.P65Warnings.ca.gov)

## Mounting Styles & Tips for Applying Them

### Extended Tie Rod Mountings – TB, TC, and TD

**Application:**

- Straight line force transfer
- Compression loads (push)  
– use TC or TD
- Tension loads (pull)  
– use TB or TD

**Advantages:**

- Ease of mounting in tight spaces
- Force is transferred along the centerline of the cylinder

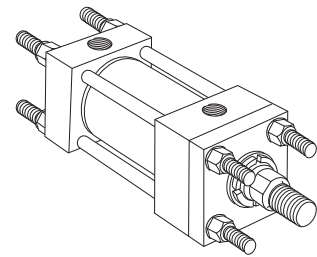

### Flange Mountings – J, JB, JJ, H, HB, and HH

**Application:**

- Straight line force transfer
- Compression loads (push)  
– use H, HB or HH
- Tension loads (pull)  
– use J, JB, or JJ

**Advantages:**

- Rigid base mounting due to large flange area
- Force is transferred along the centerline of the cylinder

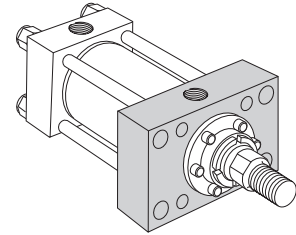

### Side Tap Mounting – F / Side Lug Mounting – C

**Application:**

- Straight line force transfer
- Can be used in compression or tension loads
- Thrust key and secure mounting area are vital

**Advantages:**

- Ease of mounting

**Recommendation:**

- Styles F & C should have a minimum stroke at least equal to the bore diameter

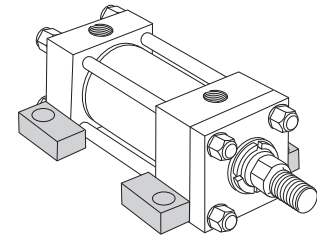

### Pivot Mountings – BB, SB and SE

**Application:**

- Curved or arc line force transfer
- Can be used in compression or tension loads
- Movement in a simple arc  
– use BB mountings
- Movement in a compound arc  
– use SB or SE mountings

**Advantages:**

- Ease of mounting
- Design flexibility
- Self aligning (SB or SE)

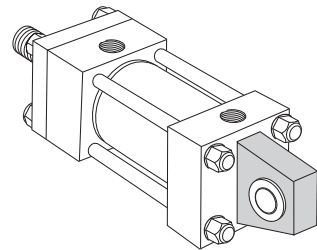

### Trunnion Mountings – D, DB, DD and DE

**Application:**

- Curved or arc line force transfer
- Can be used in compression or tension loads
- Compression loads – use DB or DD, DE mountings
- Tension loads – use D, DD or DE mountings

**Advantages:**

- Ease of mounting
- Design flexibility
- Self aligning

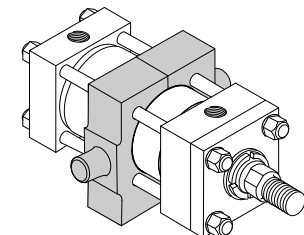

**PROP 65 WARNING**

WARNING: This product can expose you to chemicals including **Lead and Lead Compounds** which are known to the State of California to cause cancer and birth defects or other reproductive harm. For more information go to [www.P65Warnings.ca.gov](http://www.P65Warnings.ca.gov)

**PH Model Code**

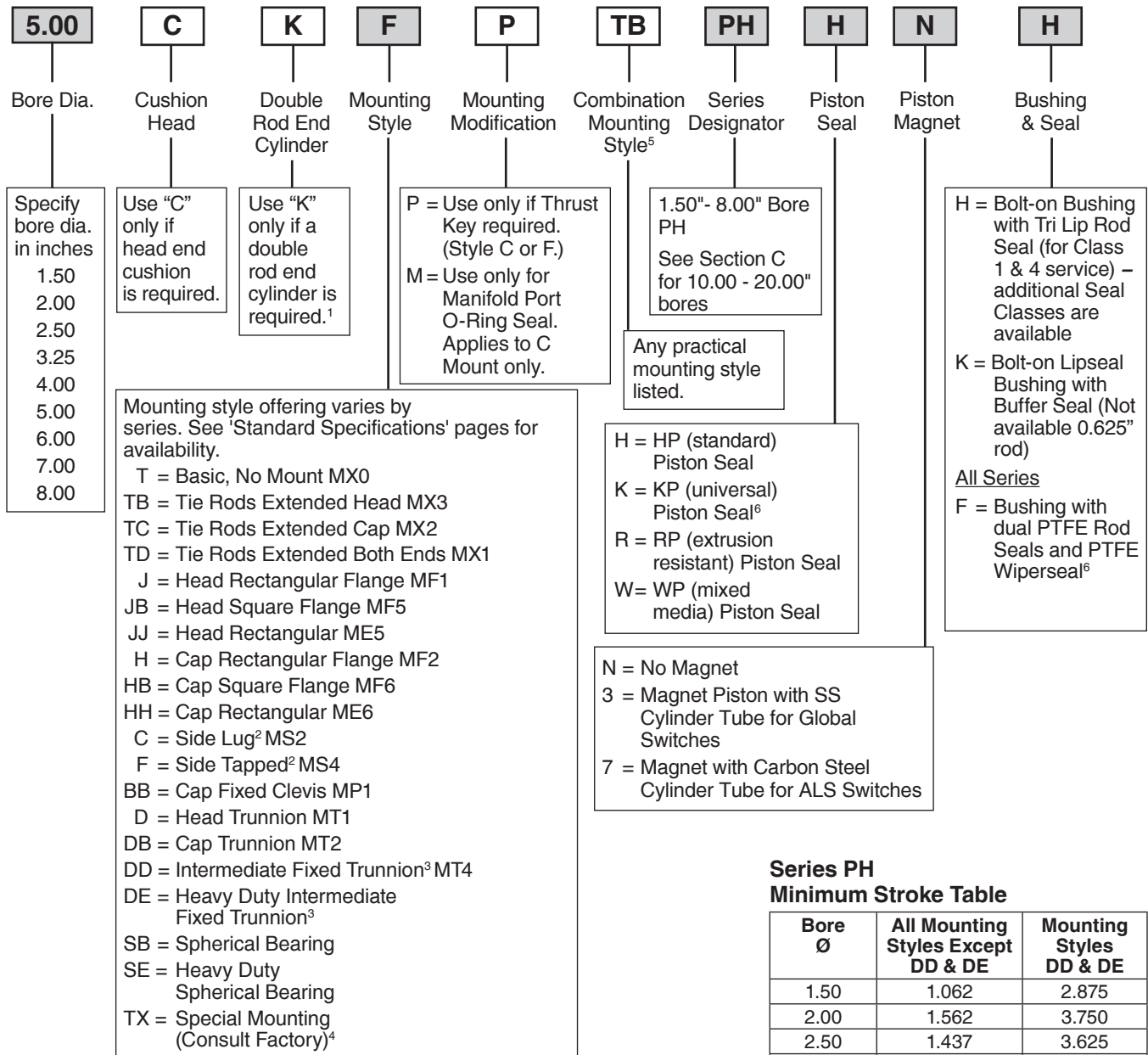

Shaded boxes identify required model number fields.

<sup>1</sup> Available mounting styles for K Type cylinders are located at the end of Section A. When ordering a double rod end cylinder, the piston rod number and piston rod end threads are to be specified for both rod ends.

The model number should be created as viewing the primary rod end on the left hand side.

Example: K Type Cylinder:

4.00CKTDPHT14A28AC10.000

<sup>2</sup> Mounting Styles C and F should have a minimum stroke length equal to or greater than their bore size.

<sup>3</sup> Specify XI dimension.

<sup>4</sup> Special mounting styles that do not resemble a standard catalog offering will be designated as style TX by the factory.

<sup>5</sup> In general, the model numbers as read left to right corresponding to the cylinder as viewed from left to right with the primary end at the left. The second or subsequent mountings are mountings called out as they appear in the assembly moving away from the rod end. Except when tie rod extension mountings are part of a combination, all combinations should have an "S" (Special) in the model code and a note in the body of the order clarifying the mounting arrangement. The "P", as used to define a thrust key is not considered to be a mounting. However it is located at the primary end.

<sup>6</sup> Piston seal code K and Bushing & Seal code F must be selected for Class 8 service. Dual PTFE rod seals with PTFE wiperseal not available for 0.625" rod.

**Series PH  
Minimum Stroke Table**

Bore Ø	All Mounting Styles Except DD & DE	Mounting Styles DD & DE
1.50	1.062	2.875
2.00	1.562	3.750
2.50	1.437	3.625
3.25	1.687	4.375
4.00	1.937	5.000
5.00	1.937	5.437
6.00	2.562	6.687
7.00	3.437	8.062
8.00	2.937	8.250

**⚠ PROP 65 WARNING** WARNING: This product can expose you to chemicals including **Lead and Lead Compounds** which are known to the State of California to cause cancer and birth defects or other reproductive harm. For more information go to [www.P65Warnings.ca.gov](http://www.P65Warnings.ca.gov)



**PH Model Code**

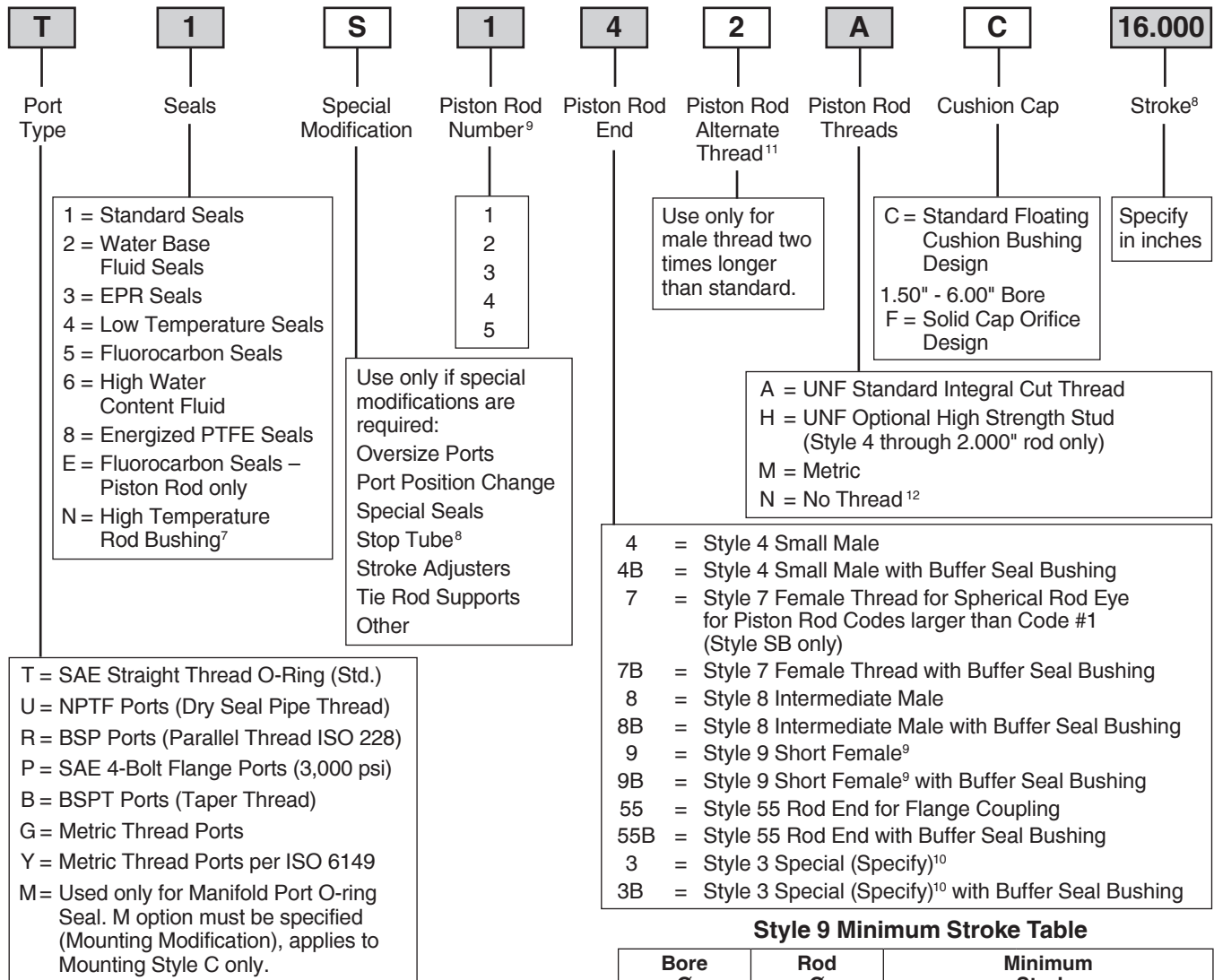

**Style 9 Minimum Stroke Table**

Bore Ø	Rod Ø	Minimum Stroke	
		Style 9	Style 9B
1.50 - 4.00	All	None	None
	2.000	None	None
5.00	2.500	1.000	0.56
	3.000	1.375	0.94
	3.500	1.625	1.19
	4.000	2.000	1.56
6.00	2.500	None	None
	3.000	1.375	0.94
	3.500	1.375	0.94
	4.000	2.000	1.56
7.00	3.000	1.250	0.81
	3.500	1.500	1.06
	4.000	1.500	1.06
	4.500	2.500	2.06
	5.000	3.125	2.31
8.00	3.500	1.500	1.06
	4.000	1.500	1.06
	4.500	2.375	1.94
	5.000	2.875	2.06
	5.500	3.625	2.81

Shaded boxes identify required model number fields.

<sup>7</sup> Energized PTFE rod seals & wiperseal. All other cylinder seals are fluorocarbon. Not available for 0.625" rod.

<sup>8</sup> S = Stop Tube. Specify: stop tube length, net stroke and gross stroke. Gross stroke = stop tube length + net stroke. Gross stroke to be placed in the model number field.

Example:

2.000 inches long stop tube  
 ±14.000 inches net stroke  
 16.000 inches gross stroke

See tables on these pages for minimum allowable strokes for Series PH and Piston Rod End Styles 9 & 9B.

<sup>9</sup> Style 9 stroke restrictions may apply. See Style 9 Minimum Stroke Table for details.

<sup>10</sup> Provide dimensions for KK, A, W or WF. If otherwise special, furnish dimensioned sketch.

<sup>11</sup> Available only in combination with Style 4 or Style 8.

<sup>12</sup> Must be specified for Piston Rod End Style 55.



**WARNING:** This product can expose you to chemicals including **Lead and Lead Compounds** which are known to the State of California to cause cancer and birth defects or other reproductive harm. For more information go to [www.P65Warnings.ca.gov](http://www.P65Warnings.ca.gov)

**Piston Seal Selection**

Schrader Bellows Piston Seal options HP, KP, RP and WP are available in a number of different Seal Classes. Because the Schrader Bellows Model Number includes Seal Class but does not include a code for piston seal style, a default piston seal style is designated for each seal class. In the table below rows list each seal class and columns column list each piston style.

Available piston styles for each seal class are identified with an 'X' and the default piston seal style is in the shaded cell. To specify an available piston seal style that is not standard, place an 'S' in the Special Modification field of the model number and specify the required piston seal style with text.

Seal Class	Piston Seal Options (Shaded cell is default standard)			
	HP	KP	RP	WP
Class 1 - Polyurethane & Nitrile	X	X	X	X
Class 2 - Nitrile	N/A	X	X	X
Class 3 - EPR	N/A	X	X	X
Class 4 - Low Temperature Nitrile	X	X	X	N/A
Class 5 - Fluorocarbon	N/A	X	X	X
Class 5 Rod Bushing Seals Only	N/A	X	X	X
Class 6 - Nitroxile	N/A	X	X	X
Class 8 - Filled PTFE High Temperature	N/A	X	N/A	N/A
Class 8 Rod Bushing Seals Only (all others Fluorocarbon)	N/A	N/A	X	X

**One Common Piston for 4 Seal Styles**

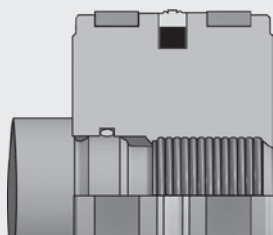

**Standard HP** style with polyurethane piston seal – excellent for most cycling and load holding applications.

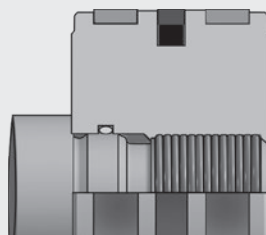

**Optional RP** style with thermoplastic piston seal – superior extrusion resistance to extreme pressure spikes with drift-free performance.

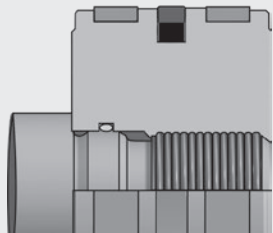

**Optional KP** style with filled PTFE piston seal – low friction, high heat resistance for cycling and load holding service.

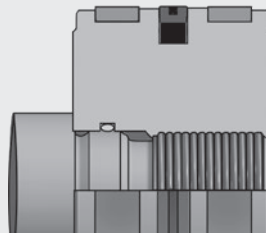

**Optional WP** style mixed media piston seal – low friction primary seal with redundant elastomer delivers superior performance with dissimilar media on either side of the piston.

**⚠ PROP 65 WARNING** WARNING: This product can expose you to chemicals including **Lead and Lead Compounds** which are known to the State of California to cause cancer and birth defects or other reproductive harm. For more information go to [www.P65Warnings.ca.gov](http://www.P65Warnings.ca.gov)

**Section B****Series PH 1.50" - 6.00" / 7.00" & 8.00" Bore  
Heavy Duty Hydraulic Cylinders**

	1.50" - 6.00" Bore	7.00" & 8.00" Bore
Specifications, Mounting Styles	11	–
Rod End Styles and Dimensions	12-13	31
T, TD, TB, TC Mount Dimensions	14	32
J Mount Dimensions	15	33
JB Mount Dimensions	16	34
JJ Mount Dimensions	17	35
H Mount Dimensions	18	36
HB Mount Dimensions	19	37
HH Mount Dimensions	20	37
C Mount Dimensions	21	38
F Mount Dimensions	22	38
BB Mount Dimensions	23	39
D Mount Dimensions	24	40
DB Mount Dimensions	25	41
DD Mount Dimensions	26	42
DE Mount Dimensions	27	43
Style SB Spherical Bearing Mounting	28	–
Style SE Spherical Bearing Mounting	29	44
Double Rod Cylinders	30	45

**⚠ PROP 65 WARNING** WARNING: This product can expose you to chemicals including **Lead and Lead Compounds** which are known to the State of California to cause cancer and birth defects or other reproductive harm. For more information go to [www.P65Warnings.ca.gov](http://www.P65Warnings.ca.gov)

**Notes**

**B**  
PH Series  
1.50" - 6.00" Bore

 **PROP 65 WARNING** **WARNING:** This product can expose you to chemicals including **Lead and Lead Compounds** which are known to the State of California to cause cancer and birth defects or other reproductive harm. For more information go to [www.P65Warnings.ca.gov](http://www.P65Warnings.ca.gov)



**Standard Specifications**

- Heavy Duty Service – ANSI/(NFPA) T3.6.7R3 - 2009 Specifications and Mounting Dimension Standards
- Standard Construction – Square Head – Tie Rod Design
- Nominal Pressure – 3000 psi<sup>1</sup>
- Standard Fluid – Hydraulic Oil
- Standard Temperature – -10°F to +165°F<sup>2</sup>
- Bore Diameters – 1.50" through 8.00" (Larger sizes available)

- Piston Rod Diameter – 0.625" through 5.500"
- Mounting Styles – 19 standard styles at various application ratings
- Strokes – Available in any practical stroke length
- Cushions – Optional at either end or both ends of stroke. "Float Check" standard at cap end of 1.50" - 6.00" bore.
- Rod Ends – Four Standard Choices – Specials to Order

*In line with our policy of continuing product improvement, specifications in this catalog are subject to change.*

Note: PH Series Hydraulic Cylinders fully meet ANSI/(NFPA) T3.6.7R3 - 2009 Specifications and Mounting Dimension Standards for Square Head Industrial Fluid Power Cylinders.

<sup>1</sup> If hydraulic operating pressure exceeds 3000 psi, send application data for engineering evaluation and recommendation. See Section D for actual design factors.

<sup>2</sup> See Section D for higher temperature service.

**Available Mounting Styles**

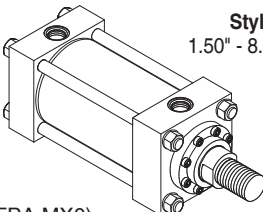
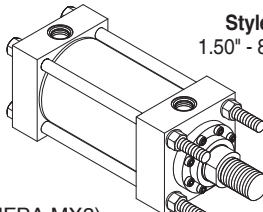
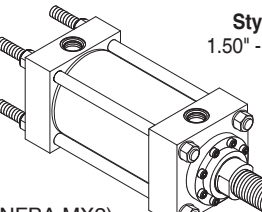
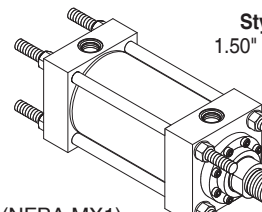
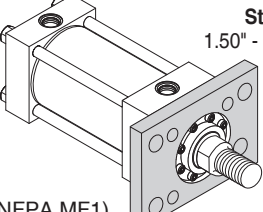
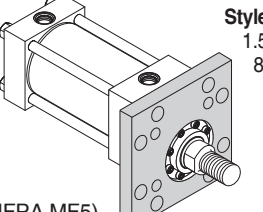
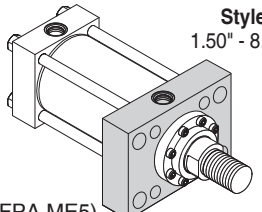
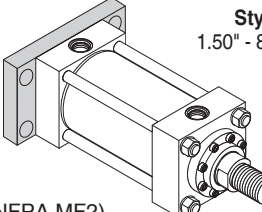
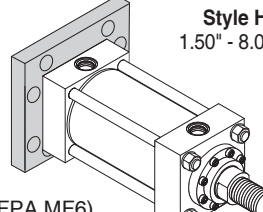
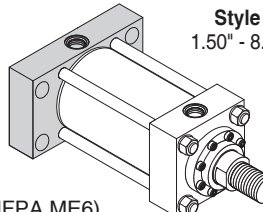
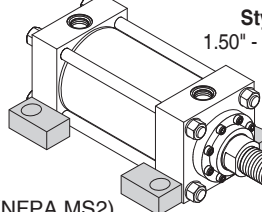
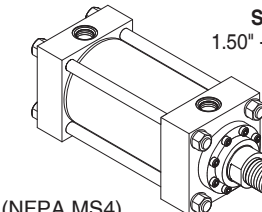
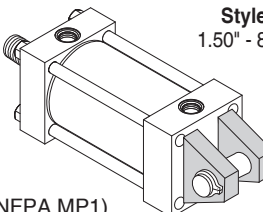
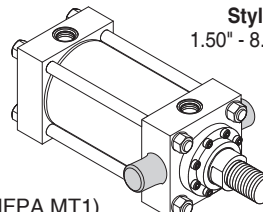
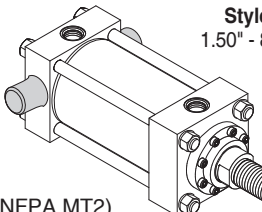
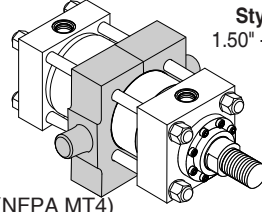
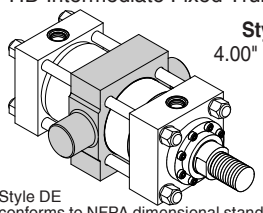
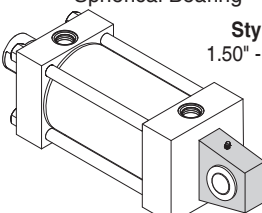
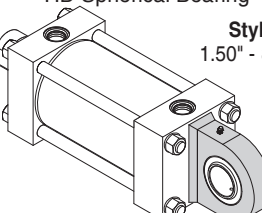
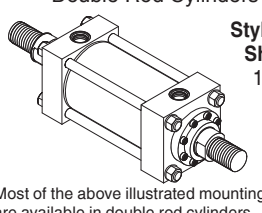
<p>Basic <b>Style T</b> 1.50" - 8.00"</p>  <p>(NFPA MX0)</p>	<p>Tie Rods Extended Head End <b>Style TB</b> 1.50" - 8.00"</p>  <p>(NFPA MX3)</p>	<p>Tie Rods Extended Cap End <b>Style TC</b> 1.50" - 8.00"</p>  <p>(NFPA MX2)</p>	<p>Tie Rods Extended Both Ends <b>Style TD</b> 1.50" - 8.00"</p>  <p>(NFPA MX1)</p>
<p>Head Rectangular Flange <b>Style J</b> 1.50" - 8.00"</p>  <p>(NFPA MF1)</p>	<p>Head Square Flange <b>Style JB</b> 1.50" - 8.00"</p>  <p>(NFPA MF5)</p>	<p>Head Rectangular <b>Style JJ</b> 1.50" - 8.00"</p>  <p>(NFPA ME5)</p>	<p>Cap Rectangular Flange <b>Style H</b> 1.50" - 8.00"</p>  <p>(NFPA MF2)</p>
<p>Cap Square Flange <b>Style HB</b> 1.50" - 8.00"</p>  <p>(NFPA MF6)</p>	<p>Cap Rectangular <b>Style HH</b> 1.50" - 8.00"</p>  <p>(NFPA ME6)</p>	<p>Side Lug <b>Style C</b> 1.50" - 8.00"</p>  <p>(NFPA MS2)</p>	<p>Side Tapped <b>Style F</b> 1.50" - 8.00"</p>  <p>(NFPA MS4)</p>
<p>Cap Fixed Clevis <b>Style BB</b> 1.50" - 8.00"</p>  <p>(NFPA MP1)</p>	<p>Head Trunnion <b>Style D</b> 1.50" - 8.00"</p>  <p>(NFPA MT1)</p>	<p>Cap Trunnion <b>Style DB</b> 1.50" - 8.00"</p>  <p>(NFPA MT2)</p>	<p>Intermediate Fixed Trunnion <b>Style DD</b> 1.50" - 8.00"</p>  <p>(NFPA MT4)</p>
<p>HD Intermediate Fixed Trunnion <b>Style DE</b> 4.00" - 8.00"</p>  <p>Style DE conforms to NFPA dimensional standard.</p>	<p>Spherical Bearing <b>Style SB</b> 1.50" - 6.00"</p> 	<p>HD Spherical Bearing <b>Style SE</b> 1.50" - 8.00"</p> 	<p>Double Rod Cylinders <b>Style KT Shown</b> 1.50" - 8.00"</p>  <p>Most of the above illustrated mounting styles are available in double rod cylinders.</p>

**B**  
PH Series  
1.50" - 8.00" Bore

**⚠ PROP 65 WARNING** WARNING: This product can expose you to chemicals including **Lead and Lead Compounds** which are known to the State of California to cause cancer and birth defects or other reproductive harm. For more information go to [www.P65Warnings.ca.gov](http://www.P65Warnings.ca.gov)

**Rod End Dimensions – circular bolt-on retainer construction**

**Thread Style 4 (NFPA Style SM)  
 Small Male**

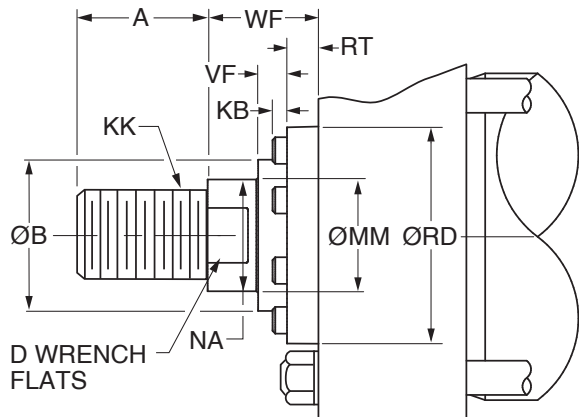

**Thread Style 8 (NFPA Style IM)  
 Intermediate Male**

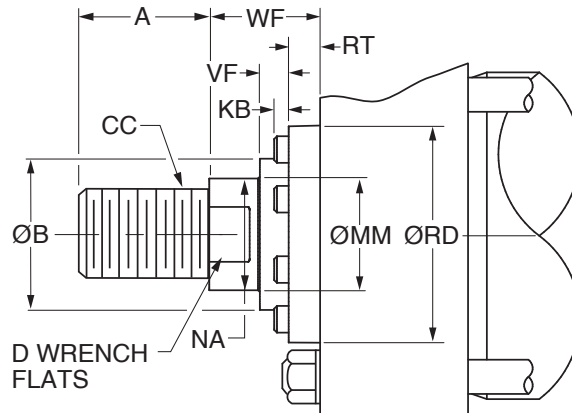

See Bushing Retention page to determine which bore, rod and mounting style combinations have circular bolt-on retainers and which have tie rod retained bushings.

**Rod End Dimensions**

Bore Ø	Rod No.	MM Rod Ø	Thread		A	B Ø +0.000 -0.002	D	F	KB	NA	RD	RT	V	VF	W	WF
			Style 8 CC	Style 4 KK												
1.50	1 (Std.)	0.625	1/2-20	7/16-20	0.75	1.124	0.50	0.38	0.03	0.56	1.94	0.36	0.25	0.27	0.63	1.00
	2	1.000	7/8-14	3/4-16	1.13	1.499	0.88	0.38	0.03	0.94	2.38	0.36	0.50	0.52	1.00	1.38
2.00	1 (Std.)	1.000	7/8-14	3/4-16	1.13	1.499	0.88	0.63	0.03	0.94	2.38	0.36	0.25	0.52	0.75	1.38
	2	1.375	1 1/4-12	1-14	1.63	1.999	1.13	0.63	0.19	1.31	2.87	0.36	0.38	0.64	1.00	1.63
2.50	1 (Std.)	1.000	7/8-14	3/4-16	1.13	1.499	0.88	0.63	0.03	0.94	2.38	0.36	0.25	0.52	0.75	1.38
	2	1.750	1 1/2-12	1 1/4-12	2.00	2.374	1.50	0.63	0.03	1.69	3.47	0.60	0.50	0.53	1.25	1.88
	3	1.375	1 1/4-12	1-14	1.63	1.999	1.13	0.63	0.19	1.31	2.87	0.36	0.38	0.64	1.00	1.63
3.25	1 (Std.)	1.375	1 1/4-12	1-14	1.63	1.999	1.13	0.75	0.19	1.31	2.87	0.36	0.25	0.64	0.88	1.63
	2	2.000	1 3/4-12	1 1/2-12	2.25	2.624	1.69	0.75	0.13	1.94	3.72	0.60	0.38	0.53	1.25	2.00
	3	1.750	1 1/2-12	1 1/4-12	2.00	2.374	1.50	0.75	0.03	1.69	3.47	0.60	0.38	0.53	1.13	1.88
4.00	1 (Std.)	1.750	1 1/2-12	1 1/4-12	2.00	2.374	1.50	0.88	0.03	1.69	3.47	0.60	0.25	0.53	1.00	1.88
	2	2.500	2 1/4-12	1 7/8-12	3.00	3.124	2.06	0.88	0.25	2.38	4.25	0.60	0.38	0.65	1.38	2.25
	3	2.000	1 3/4-12	1 1/2-12	2.25	2.624	1.69	0.88	0.13	1.94	3.72	0.60	0.25	0.53	1.13	2.00
5.00	1 (Std.)	2.000	1 3/4-12	1 1/2-12	2.25	2.624	1.69	0.88	0.13	1.94	3.72	0.60	0.25	0.53	1.13	2.00
	2	3.500	3 1/4-12	2 1/2-12	3.50	4.249	3.00	0.88	-	3.38	5.76	0.91	0.38	0.34	1.38	2.25
	3	2.500	2 1/4-12	1 7/8-12	3.00	3.124	2.06	0.88	0.25	2.38	4.25	0.60	0.38	0.65	1.38	2.25
	4	3.000	2 3/4-12	2 1/4-12	3.50	3.749	2.63	0.88	-	2.88	5.26	0.85	0.38	0.41	1.38	2.25
6.00	1 (Std.)	2.500	2 1/4-12	1 7/8-12	3.00	3.124	2.06	1.00	0.25	2.38	4.25	0.60	0.25	0.65	1.25	2.25
	2	4.000	3 3/4-12	3-12	4.00	4.749	3.38	1.00	-	3.88	6.31	0.91	0.25	0.34	1.25	2.25
	3	3.000	2 3/4-12	2 1/4-12	3.50	3.749	2.63	1.00	-	2.88	5.26	0.85	0.25	0.41	1.25	2.25
	4	3.500	3 1/4-12	2 1/2-12	3.50	4.249	3.00	1.00	-	3.38	5.76	0.91	0.25	0.34	1.25	2.25

**“Special” Thread Style 3 (Previous Style X)**

Special thread, extension, rod eye, blank, etc., are also available.

To order, specify “Style 3” and give desired dimensions for KK, A, W or WF. If otherwise special, furnish dimensioned sketch.

**⚠ PROP 65 WARNING** WARNING: This product can expose you to chemicals including **Lead and Lead Compounds** which are known to the State of California to cause cancer and birth defects or other reproductive harm. For more information go to [www.P65Warnings.ca.gov](http://www.P65Warnings.ca.gov)

PH Series  
 1.50" - 6.00" Bore  
**B**

**Rod End Dimensions – circular bolt-on retainer construction**

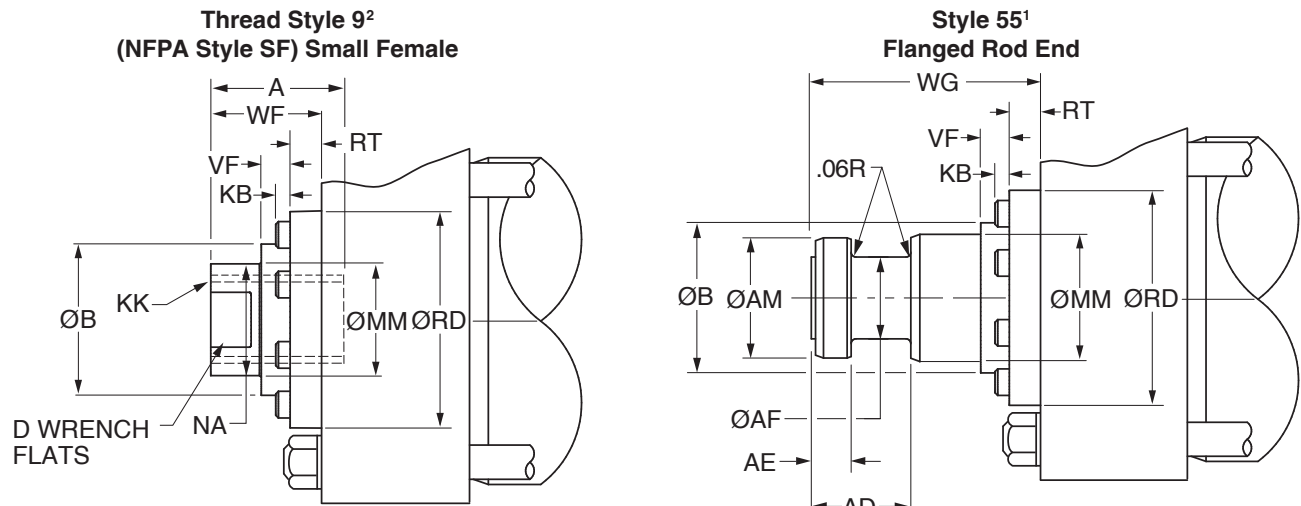

See Bushing Retention page to determine which bore, rod and mounting style combinations have circular bolt-on retainers and which have tie rod retained bushings.



**Rod End Dimensions**

Bore Ø	Rod No.	MM Rod Ø	Thread	A	AD	AE +.001 -.001	AF Ø	AM Ø	B Ø +.000 -.002	D	KB	NA	RD	RT	VF	WF	WG
			Style 9 KK														
1.50	1 (Std.)	0.625	7/16-20	0.75	0.63	0.249	0.38	0.57	1.124	0.50	0.03	0.56	1.94	0.36	0.27	1.00	1.75
	2	1.000	3/4-16	1.13	0.94	0.374	0.69	0.95	1.499	0.88	0.03	0.94	2.38	0.36	0.52	1.38	2.38
2.00	1 (Std.)	1.000	3/4-16	1.13	0.94	0.374	0.69	0.95	1.499	0.88	0.03	0.94	2.38	0.36	0.52	1.38	2.38
	2	1.375	1-14	1.63	1.06	0.374	0.88	1.32	1.999	1.13	0.19	1.31	2.87	0.36	0.64	1.63	2.75
2.50	1 (Std.)	1.000	3/4-16	1.13	0.94	0.374	0.69	0.95	1.499	0.88	0.03	0.94	2.38	0.36	0.52	1.38	2.38
	2	1.750	1 1/4-12	2.00	1.31	0.499	1.13	1.70	2.374	1.50	0.03	1.69	3.47	0.60	0.53	1.88	3.13
	3	1.375	1-14	1.63	1.06	0.374	0.88	1.32	1.999	1.13	0.19	1.31	2.87	0.36	0.64	1.63	2.75
3.25	1 (Std.)	1.375	1-14	1.63	1.06	0.374	0.88	1.32	1.999	1.13	0.19	1.31	2.87	0.36	0.64	1.63	2.75
	2	2.000	1 1/2-12	2.25	1.69	0.624	1.38	1.95	2.624	1.69	0.13	1.94	3.72	0.60	0.53	2.00	3.75
	3	1.750	1 1/4-12	2.00	1.31	0.499	1.13	1.70	2.374	1.50	0.03	1.69	3.47	0.60	0.53	1.88	3.13
4.00	1 (Std.)	1.750	1 1/4-12	2.00	1.31	0.499	1.13	1.70	2.374	1.50	0.03	1.69	3.47	0.60	0.53	1.88	3.13
	2	2.500	1 7/8-12	3.00	1.94	0.749	1.75	2.45	3.124	2.06	0.25	2.38	4.25	0.60	0.65	2.25	4.50
	3	2.000	1 1/2-12	2.25	1.69	0.624	1.38	1.95	2.624	1.69	0.13	1.94	3.72	0.60	0.53	2.00	3.75
5.00	1 (Std.)	2.000	1 1/2-12	2.25	1.69	0.624	1.38	1.95	2.624	1.69	0.13	1.94	3.72	0.60	0.53	2.00	3.75
	2	3.500	2 1/2-12	3.50	2.69	0.999	2.50	3.45	4.249	3.00	-	3.38	5.76	0.91	0.34	2.25	5.63
	3	2.500	1 7/8-12	3.00	1.94	0.749	1.75	2.45	3.124	2.06	0.25	2.38	4.25	0.60	0.65	2.25	4.50
	4	3.000	2 1/4-12	3.50	2.44	0.874	2.25	2.95	3.749	2.63	-	2.88	5.26	0.85	0.41	2.25	4.88
6.00	1 (Std.)	2.500	1 7/8-12	3.00	1.94	0.749	1.75	2.45	3.124	2.06	0.25	2.38	4.25	0.60	0.65	2.25	4.50
	2	4.000	3-12	4.00	2.69	0.999	3.00	3.95	4.749	3.38	-	3.88	6.31	0.91	0.34	2.25	5.75
	3	3.000	2 1/4-12	3.50	2.44	0.874	2.25	2.95	3.749	2.63	-	2.88	5.26	0.85	0.41	2.25	4.88
	4	3.500	2 1/2-12	3.50	2.69	0.999	2.50	3.45	4.249	3.00	-	3.38	5.76	0.91	0.34	2.25	5.63

**“Special” Thread Style 3 (Previous Style X)**

Special thread, extension, rod eye, blank, etc., are also available.

To order, specify “Style 3” and give desired dimensions for KK, A, W or WF. If otherwise special, furnish dimensioned sketch.

<sup>1</sup> For special WG dimension, specify “Style 3” and give desired dimension for WG. For other changes, place “S” in the model code, and describe rod end with dimensioned sketch.

<sup>2</sup> Style 9 stroke restrictions may apply. See Style 9 Minimum Stroke Table on How to Order page for details.

**⚠ PROP 65 WARNING** WARNING: This product can expose you to chemicals including **Lead and Lead Compounds** which are known to the State of California to cause cancer and birth defects or other reproductive harm. For more information go to [www.P65Warnings.ca.gov](http://www.P65Warnings.ca.gov)

**Tie Rods Extended Both Ends Mounting**  
**Style TD**  
 (NFA Style MX1)

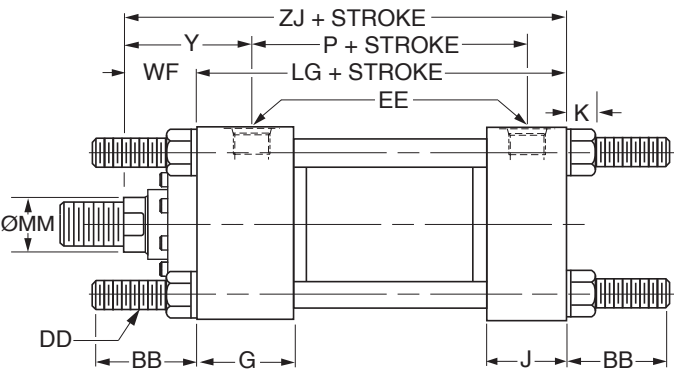
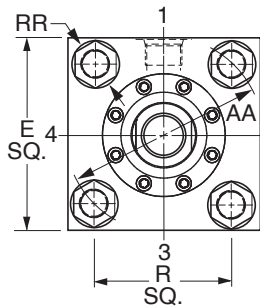
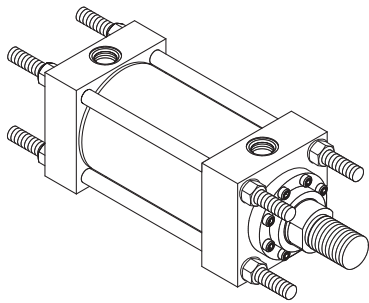

**Style TD – Dimensional and Mounting Data**

Bore Ø	Rod No.	MM Rod Ø	AA	BB	DD	E	EE		G	J	K Max.	R	RR	WF	Y	Add Stroke		
							NPTF <sup>1</sup>	SAE <sup>2</sup>								LG	P	ZJ
1.50	1 (std.)	0.625	2.31	1.38	3/8-24	2.50	1/2	10 <sup>†</sup>	1.75	1.50	0.42	1.63	0.68	1.00	2.00	4.63	2.88	5.63
	2	1.000	2.31	1.38	3/8-24	2.50	1/2	10 <sup>†</sup>	1.75	1.50	0.42	1.63	0.68	1.38	2.38	4.63	2.88	6.00
2.00	1 (std.)	1.000	2.90	1.81	1/2-20	3.00	1/2	10 <sup>†</sup>	1.75	1.50	0.57	2.05	0.90	1.38	2.38	4.63	2.88	6.00
	2	1.375	2.90	1.81	1/2-20	3.00	1/2	10 <sup>†</sup>	1.75	1.50	0.57	2.05	0.90	1.63	2.63	4.63	2.88	6.25
2.50	1 (std.)	1.000	3.61	1.81	1/2-20	3.50	1/2	10 <sup>†</sup>	1.75	1.50	0.57	2.55	0.90	1.38	2.38	4.75	3.00	6.13
	2	1.750	3.61	1.81	1/2-20	3.50	1/2	10 <sup>†</sup>	1.75	1.50	0.57	2.55	0.90	1.88	2.88	4.75	3.00	6.63
	3	1.375	3.61	1.81	1/2-20	3.50	1/2	10 <sup>†</sup>	1.75	1.50	0.57	2.55	0.90	1.63	2.63	4.75	3.00	6.38
3.25	1 (std.)	1.375	4.60	2.31	5/8-18	4.50	3/4	12	2.00	1.75	0.68	3.25	1.11	1.63	2.75	5.50	3.50	7.13
	2	2.000	4.60	2.31	5/8-18	4.50	3/4	12	2.00	1.75	0.68	3.25	1.11	2.00	3.13	5.50	3.50	7.50
	3	1.750	4.60	2.31	5/8-18	4.50	3/4	12	2.00	1.75	0.68	3.25	1.11	1.88	3.00	5.50	3.50	7.38
4.00	1 (std.)	1.750	5.40	2.31	5/8-18	5.00	3/4	12	2.00	1.75	0.68	3.82	1.11	1.88	3.00	5.75	3.75	7.63
	2	2.500	5.40	2.31	5/8-18	5.00	3/4	12	2.00	1.75	0.68	3.82	1.11	2.25	3.38	5.75	3.75	8.00
	3	2.000	5.40	2.31	5/8-18	5.00	3/4	12	2.00	1.75	0.68	3.82	1.11	2.00	3.13	5.75	3.75	7.75
5.00	1 (std.)	2.000	7.00	3.19	7/8-14	6.50	3/4	12	2.00	1.75	0.94	4.95	1.55	2.00	3.13	6.25	4.25	8.25
	2	3.500	7.00	3.19	7/8-14	6.50	3/4	12	2.00	1.75	0.94	4.95	1.55	2.25	3.38	6.25	4.25	8.50
	3	2.500	7.00	3.19	7/8-14	6.50	3/4	12	2.00	1.75	0.94	4.95	1.55	2.25	3.38	6.25	4.25	8.50
	4	3.000	7.00	3.19	7/8-14	6.50	3/4	12	2.00	1.75	0.94	4.95	1.55	2.25	3.38	6.25	4.25	8.50
6.00	1 (std.)	2.500	8.10	3.63	1-14	7.50	1	16	2.25	2.25	1.05	5.73	1.77	2.25	3.50	7.38	4.88	9.63
	2	4.000	8.10	3.63	1-14	7.50	1	16	2.25	2.25	1.05	5.73	1.77	2.25	3.50	7.38	4.88	9.63
	3	3.000	8.10	3.63	1-14	7.50	1	16	2.25	2.25	1.05	5.73	1.77	2.25	3.50	7.38	4.88	9.63
	4	3.500	8.10	3.63	1-14	7.50	1	16	2.25	2.25	1.05	5.73	1.77	2.25	3.50	7.38	4.88	9.63

<sup>1</sup>NPTF ports are available at no extra charge.

<sup>2</sup>SAE straight thread ports are standard and are indicated by port number.

<sup>†</sup>Previously number 8 SAE in 1.50 thru 2.50 bores now number 10 SAE.

**Style T**

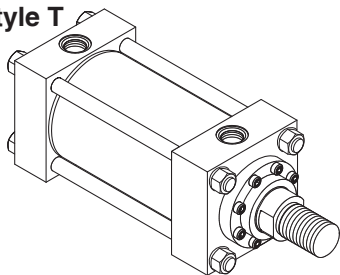

**Style TC**

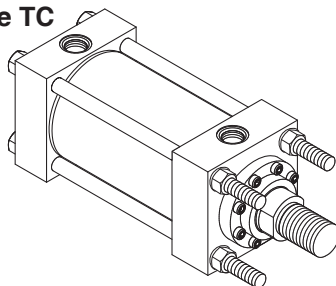

**Style TB**

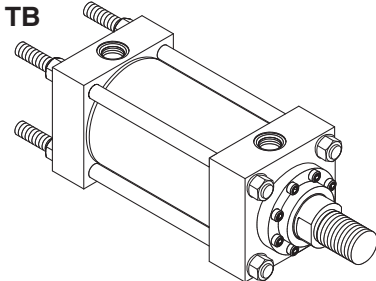

Dimensions for T, TB and TC Mount may be obtained from the above dimensional table.

**⚠ PROP 65 WARNING** WARNING: This product can expose you to chemicals including **Lead and Lead Compounds** which are known to the State of California to cause cancer and birth defects or other reproductive harm. For more information go to [www.P65Warnings.ca.gov](http://www.P65Warnings.ca.gov)

PH Series  
 1.50" - 8.00" Bore

**Head Rectangular Flange Mounting**

Style J  
(NFPA Style MF1)

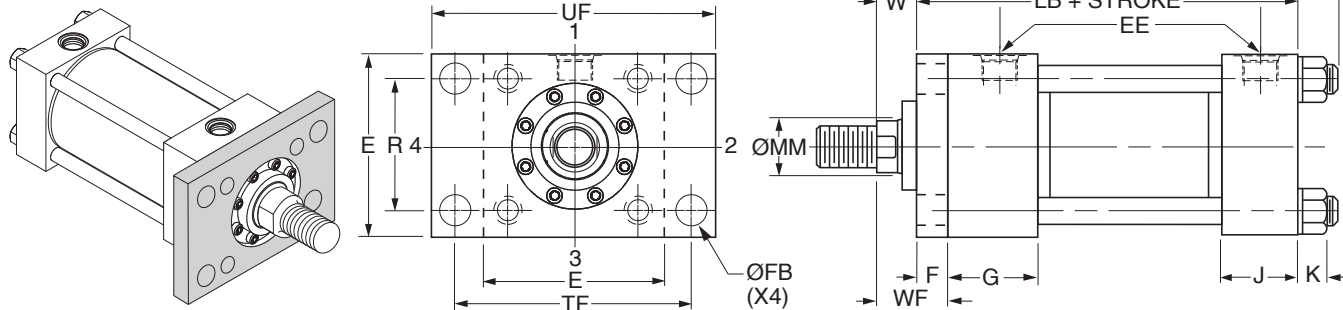

**Style J – Dimensional and Mounting Data**

Bore Ø	E	EE		F	FB Ø	G	J	K Max.	R	TF	UF	Add Stroke	
		NPTF <sup>1</sup>	SAE <sup>2</sup>									LB	P
1.50	2.50	1/2	10 <sup>†</sup>	0.38	0.44	1.75	1.50	0.42	1.63	3.44	4.25	5.00	2.88
2.00	3.00	1/2	10 <sup>†</sup>	0.63	0.56	1.75	1.50	0.57	2.05	4.13	5.13	5.25	2.88
2.50	3.50	1/2	10 <sup>†</sup>	0.63	0.56	1.75	1.50	0.57	2.55	4.63	5.63	5.38	3.00
3.25	4.50	3/4	12	0.75	0.69	2.00	1.75	0.68	3.25	5.88	7.13	6.25	3.50
4.00	5.00	3/4	12	0.88	0.69	2.00	1.75	0.68	3.82	6.38	7.63	6.63	3.75
5.00	6.50	3/4	12	0.88	0.94	2.00	1.75	0.94	4.95	8.19	9.75	7.13	4.25
6.00	7.50	1	16	1.00	1.06	2.25	2.25	1.05	5.73	9.44	11.25	8.38	4.88

<sup>1</sup>NPTF ports are available at no extra charge.

<sup>2</sup>SAE straight thread ports are standard and are indicated by port number.

<sup>†</sup>Previously number 8 SAE in 1.50 thru 2.50 bores now number 10 SAE.

**Style J – Dimensional and Mounting Data**

Bore Ø	Rod No.	MM Rod Ø	W	WF	Y	Add Stroke
						ZB Max.
1.50	1 (std.)	0.625	0.63	1.00	2.00	6.29
	2	1.000	1.00	1.38	2.38	6.67
2.00	1 (std.)	1.000	0.75	1.38	2.38	6.81
	2	1.375	1.00	1.63	2.63	7.06
2.50	1 (std.)	1.000	0.75	1.38	2.38	6.93
	2	1.750	1.25	1.88	2.88	7.43
	3	1.375	1.00	1.63	2.63	7.18
3.25	1 (std.)	1.375	0.88	1.63	2.75	8.06
	2	2.000	1.25	2.00	3.13	8.43
	3	1.750	1.13	1.88	3.00	8.31
4.00	1 (std.)	1.750	1.00	1.88	3.00	8.56
	2	2.500	1.38	2.25	3.38	8.94
	3	2.000	1.13	2.00	3.13	8.68
5.00	1 (std.)	2.000	1.13	2.00	3.13	9.44
	2	3.500	1.38	2.25	3.38	9.69
	3	2.500	1.38	2.25	3.38	9.69
	4	3.000	1.38	2.25	3.38	9.69
6.00	1 (std.)	2.500	1.25	2.25	3.50	10.93
	2	4.000	1.25	2.25	3.50	10.93
	3	3.000	1.25	2.25	3.50	10.93
	4	3.500	1.25	2.25	3.50	10.93

**Style J – Maximum Operating Pressure**

Bore Ø	Maximum psi Push <sup>3</sup>			
	Rod Code			
	1	2	3	4
1.50	1400	1000	-	-
2.00	2000	1200	-	-
2.50	700	1000	700	-
3.25	800	600	800	-
4.00	1000	700	1000	-
5.00	850	800	850	450
6.00	650	400	650	400

<sup>3</sup>Maximum Pressure Rating – Push Application.

**B**  
PH Series  
1.50" - 8.00" Bore

**⚠ PROP 65 WARNING** WARNING: This product can expose you to chemicals including **Lead and Lead Compounds** which are known to the State of California to cause cancer and birth defects or other reproductive harm. For more information go to [www.P65Warnings.ca.gov](http://www.P65Warnings.ca.gov)

**Head Square Flange Mounting**  
**Style JB**  
**(NPTA Style MF5)**

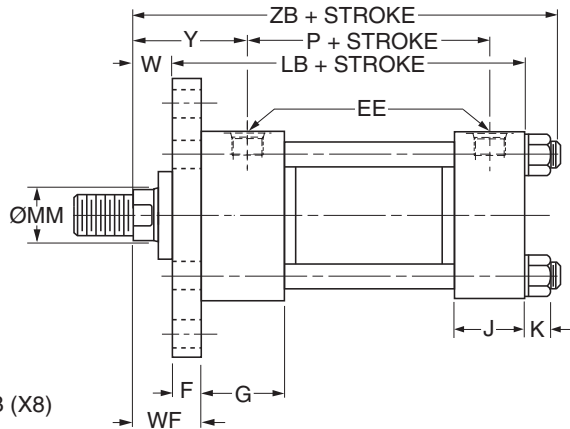
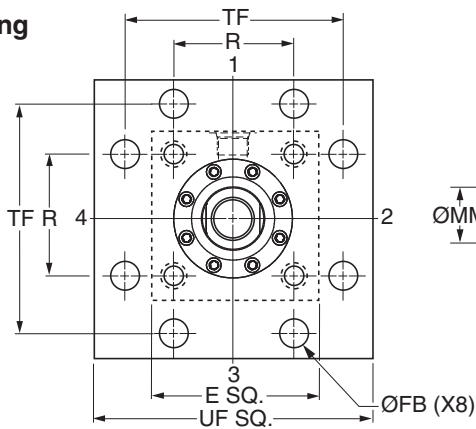
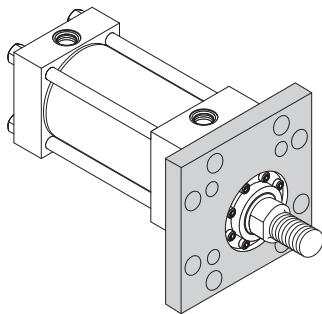

**Style JB – Dimensional and Mounting Data**

Bore Ø	E	EE		F	FB Ø	G	J	K Max.	R	TF	UF	Add Stroke	
		NPTF <sup>1</sup>	SAE <sup>2</sup>									LB	P
1.50	2.50	1/2	10 <sup>†</sup>	0.38	0.44	1.75	1.50	0.42	1.63	3.44	4.25	5.00	2.88
2.00	3.00	1/2	10 <sup>†</sup>	0.63	0.56	1.75	1.50	0.57	2.05	4.13	5.13	5.25	2.88
2.50	3.50	1/2	10 <sup>†</sup>	0.63	0.56	1.75	1.50	0.57	2.55	4.63	5.63	5.38	3.00
3.25	4.50	3/4	12	0.75	0.69	2.00	1.75	0.68	3.25	5.88	7.13	6.25	3.50
4.00	5.00	3/4	12	0.88	0.69	2.00	1.75	0.68	3.82	6.38	7.63	6.63	3.75
5.00	6.50	3/4	12	0.88	0.94	2.00	1.75	0.94	4.95	8.19	9.75	7.13	4.25
6.00	7.50	1	16	1.00	1.06	2.25	2.25	1.05	5.73	9.44	11.25	8.38	4.88

<sup>1</sup>NPTF ports are available at no extra charge.

<sup>2</sup>SAE straight thread ports are standard and are indicated by port number.

<sup>†</sup>Previously number 8 SAE in 1.50 thru 2.50 bores now number 10 SAE.

**Style JB – Dimensional and Mounting Data**

Bore Ø	Rod No.	MM Rod Ø	W	WF	Y	Add Stroke
						ZB Max.
1.50	1 (std.)	0.625	0.63	1.00	2.00	6.29
	2	1.000	1.00	1.38	2.38	6.67
2.00	1 (std.)	1.000	0.75	1.38	2.38	6.81
	2	1.375	1.00	1.63	2.63	7.06
2.50	1 (std.)	1.000	0.75	1.38	2.38	6.93
	2	1.750	1.25	1.88	2.88	7.43
	3	1.375	1.00	1.63	2.63	7.18
3.25	1 (std.)	1.375	0.88	1.63	2.75	8.06
	2	2.000	1.25	2.00	3.13	8.43
	3	1.750	1.13	1.88	3.00	8.31
4.00	1 (std.)	1.750	1.00	1.88	3.00	8.56
	2	2.500	1.38	2.25	3.38	8.94
	3	2.000	1.13	2.00	3.13	8.68
5.00	1 (std.)	2.000	1.13	2.00	3.13	9.44
	2	3.500	1.38	2.25	3.38	9.69
	3	2.500	1.38	2.25	3.38	9.69
	4	3.000	1.38	2.25	3.38	9.69
6.00	1 (std.)	2.500	1.25	2.25	3.50	10.93
	2	4.000	1.25	2.25	3.50	10.93
	3	3.000	1.25	2.25	3.50	10.93
	4	3.500	1.25	2.25	3.50	10.93

**Style JB – Maximum Operating Pressure**

Bore Ø	Maximum psi Push <sup>3</sup>			
	Rod Code			
	1	2	3	4
1.50	3000	3000	-	-
2.00	3000	3000	-	-
2.50	3000	3000	3000	-
3.25	3000	3000	3000	-
4.00	3000	3000	3000	-
5.00	2500	2300	2500	1800
6.00	2000	1600	2000	1600

<sup>3</sup>Maximum Pressure Rating – Push Application.

**⚠ PROP 65 WARNING** WARNING: This product can expose you to chemicals including **Lead and Lead Compounds** which are known to the State of California to cause cancer and birth defects or other reproductive harm. For more information go to [www.P65Warnings.ca.gov](http://www.P65Warnings.ca.gov)

PH Series  
 1.50" - 8.00" Bore

**Head Rectangular Mounting**  
 Style JJ  
 (NFPA Style ME5)

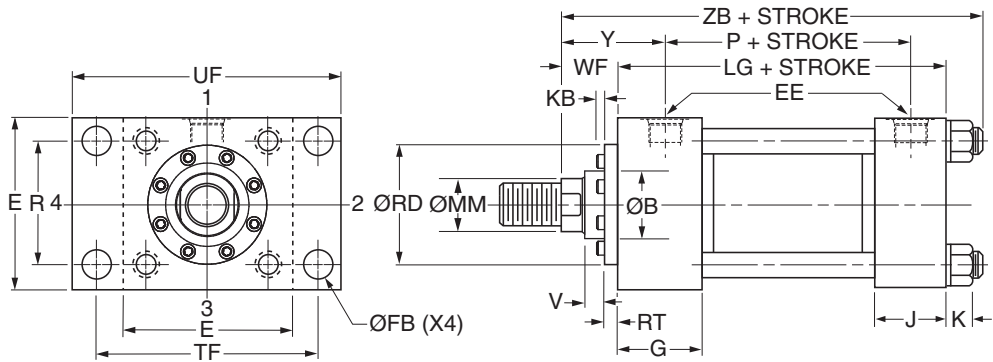
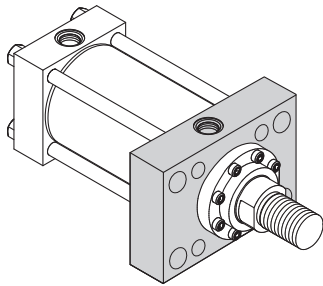

**Style JJ – Dimensional and Mounting Data**

Bore Ø	E	EE		FB Ø	G	J	K Max.	R	TF	UF	Add Stroke	
		NPTF <sup>1</sup>	SAE <sup>2</sup>								LG	P
1.50	2.50	1/2	10 <sup>†</sup>	0.44	1.75	1.50	0.42	1.63	3.44	4.25	4.63	2.88
2.00	3.00	1/2	10 <sup>†</sup>	0.56	1.75	1.50	0.57	2.05	4.13	5.13	4.63	2.88
2.50	3.50	1/2	10 <sup>†</sup>	0.56	1.75	1.50	0.57	2.55	4.63	5.63	4.75	3.00
3.25	4.50	3/4	12	0.69	2.00	1.75	0.68	3.25	5.88	7.13	5.50	3.50
4.00	5.00	3/4	12	0.69	2.00	1.75	0.68	3.82	6.38	7.63	5.75	3.75
5.00	6.50	3/4	12	0.94	2.00	1.75	0.94	4.95	8.19	9.75	6.25	4.25
6.00	7.50	1	16	1.06	2.25	2.25	1.05	5.73	9.44	11.25	7.38	4.88

<sup>1</sup>NPTF ports are available at no extra charge.

<sup>2</sup>SAE straight thread ports are standard and are indicated by port number.

<sup>†</sup>Previously number 8 SAE in 1.50 thru 2.50 bores now number 10 SAE.

**Style JJ – Dimensional and Mounting Data**

Bore Ø	Rod No.	MM Rod Ø	B Ø +.000 -0.002	KB	RD Ø	RT	V	WF	Y	Add Stroke
										ZB Max
1.50	1 (std.)	0.625	1.124	0.03	1.94	0.36	0.27	1.00	2.00	6.29
	2	1.000	1.499	0.03	2.38	0.36	0.52	1.38	2.38	6.67
2.00	1 (std.)	1.000	1.499	0.03	2.38	0.36	0.52	1.38	2.38	6.81
	2	1.375	1.999	0.19	2.87	0.36	0.64	1.63	2.63	7.06
2.50	1 (std.)	1.000	1.499	0.03	2.38	0.36	0.52	1.38	2.38	6.93
	2	1.750	2.374	0.03	3.47	0.60	0.53	1.88	2.88	7.43
	3	1.375	1.999	0.19	2.87	0.36	0.64	1.63	2.63	7.18
3.25	1 (std.)	1.375	1.999	0.19	2.87	0.36	0.64	1.63	2.75	8.06
	2	2.000	2.624	0.13	3.72	0.60	0.53	2.00	3.13	8.43
	3	1.750	2.374	0.03	3.47	0.60	0.53	1.88	3.00	8.31
4.00	1 (std.)	1.750	2.374	0.03	3.47	0.60	0.53	1.88	3.00	8.56
	2	2.500	3.124	0.25	4.25	0.60	0.65	2.25	3.38	8.94
	3	2.000	2.624	0.13	3.72	0.60	0.53	2.00	3.13	8.68
5.00	1 (std.)	2.000	2.624	0.13	3.72	0.60	0.53	2.00	3.13	9.44
	2	3.500	4.249	-	5.76	0.91	0.34	2.25	3.38	9.69
	3	2.500	3.124	0.25	4.25	0.60	0.65	2.25	3.38	9.69
	4	3.000	3.749	-	5.26	0.85	0.41	2.25	3.38	9.69
6.00	1 (std.)	2.500	3.124	0.25	4.25	0.60	0.65	2.25	3.50	10.93
	2	4.000	4.749	-	6.31	0.91	0.34	2.25	3.50	10.93
	3	3.000	3.749	-	5.26	0.85	0.41	2.25	3.50	10.93
	4	3.500	4.249	-	5.76	0.91	0.34	2.25	3.50	10.93

**B**  
 PH Series  
 1.50" - 8.00" Bore

**⚠ PROP 65 WARNING** WARNING: This product can expose you to chemicals including **Lead and Lead Compounds** which are known to the State of California to cause cancer and birth defects or other reproductive harm. For more information go to [www.P65Warnings.ca.gov](http://www.P65Warnings.ca.gov)

**Cap Rectangular Flange Mounting**  
**Style H**  
**(NFFA Style MF2)**

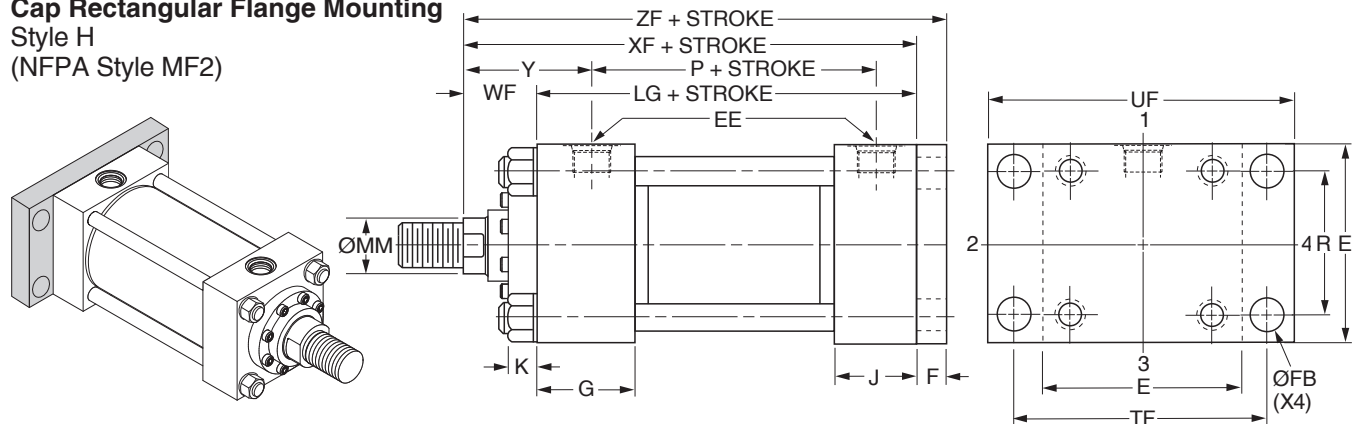

**Style H – Dimensional and Mounting Data**

Bore Ø	E	EE		F	FB Ø	G	J	K Max.	R	TF	UF	Add Stroke	
		NPTF <sup>1</sup>	SAE <sup>2</sup>									LG	P
1.50	2.50	1/2	10 <sup>†</sup>	0.38	0.44	1.75	1.50	0.42	1.63	3.44	4.25	4.63	2.88
2.00	3.00	1/2	10 <sup>†</sup>	0.63	0.56	1.75	1.50	0.57	2.05	4.13	5.13	4.63	2.88
2.50	3.50	1/2	10 <sup>†</sup>	0.63	0.56	1.75	1.50	0.57	2.55	4.63	5.63	4.75	3.00
3.25	4.50	3/4	12	0.75	0.69	2.00	1.75	0.68	3.25	5.88	7.13	5.50	3.50
4.00	5.00	3/4	12	0.88	0.69	2.00	1.75	0.68	3.82	6.38	7.63	5.75	3.75
5.00	6.50	3/4	12	0.88	0.94	2.00	1.75	0.94	4.95	8.19	9.75	6.25	4.25
6.00	7.50	1	16	1.00	1.06	2.25	2.25	1.05	5.73	9.44	11.25	7.38	4.88

<sup>1</sup>NPTF ports are available at no extra charge.

<sup>2</sup>SAE straight thread ports are standard and are indicated by port number.

<sup>†</sup>Previously number 8 SAE in 1.50 thru 2.50 bores now number 10 SAE.

**Style H – Dimensional and Mounting Data**

Bore Ø	Rod No.	MM Rod Ø	WF	Y	Add Stroke	
					XF	ZF
1.50	1 (std.)	0.625	1.00	2.00	5.63	6.00
	2	1.000	1.38	2.38	6.00	6.38
2.00	1 (std.)	1.000	1.38	2.38	6.00	6.63
	2	1.375	1.63	2.63	6.25	6.88
2.50	1 (std.)	1.000	1.38	2.38	6.13	6.75
	2	1.750	1.88	2.88	6.63	7.25
	3	1.375	1.63	2.63	6.38	7.00
3.25	1 (std.)	1.375	1.63	2.75	7.13	7.88
	2	2.000	2.00	3.13	7.50	8.25
	3	1.750	1.88	3.00	7.38	8.13
4.00	1 (std.)	1.750	1.88	3.00	7.63	8.50
	2	2.500	2.25	3.38	8.00	8.88
	3	2.000	2.00	3.13	7.75	8.63
5.00	1 (std.)	2.000	2.00	3.13	8.25	9.13
	2	3.500	2.25	3.38	8.50	9.38
	3	2.500	2.25	3.38	8.50	9.38
	4	3.000	2.25	3.38	8.50	9.38
6.00	1 (std.)	2.500	2.25	3.50	9.63	10.63
	2	4.000	2.25	3.50	9.63	10.63
	3	3.000	2.25	3.50	9.63	10.63
	4	3.500	2.25	3.50	9.63	10.63

**Style H – Maximum Operating Pressure**

Bore Ø	Maximum psi Pull <sup>3</sup>			
	Rod Code			
	1	2	3	4
1.50	2500	3000	-	-
2.00	3000	3000	-	-
2.50	3000	3000	3000	-
3.25	3000	3000	3000	-
4.00	3000	3000	3000	-
5.00	2000	3000	2000	2500
6.00	1800	2500	2000	2000

<sup>3</sup> Maximum pressure rating — pull application.

**⚠ PROP 65 WARNING** WARNING: This product can expose you to chemicals including **Lead and Lead Compounds** which are known to the State of California to cause cancer and birth defects or other reproductive harm. For more information go to [www.P65Warnings.ca.gov](http://www.P65Warnings.ca.gov)

PH Series  
 1.50" - 8.00" Bore



**Cap Square Flange Mounting**

Style HB  
 (NFPA Style MF6)

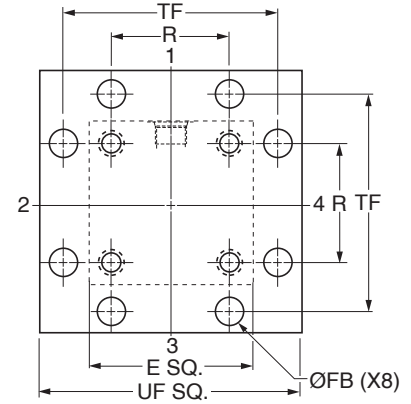
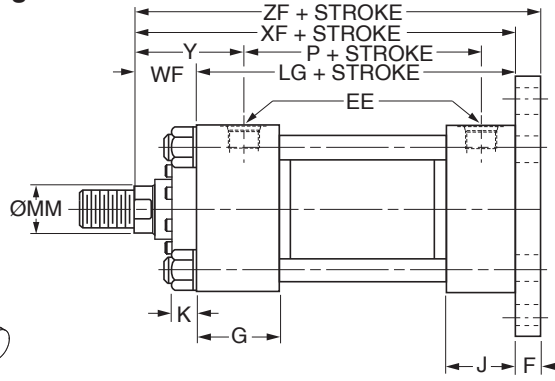
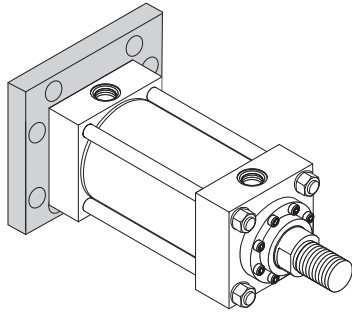

**Style HB – Dimensional and Mounting Data**

Bore Ø	E	EE		F	FB Ø	G	J	K Max.	R	TF	UF	Add Stroke	
		NPTF <sup>1</sup>	SAE <sup>2</sup>									LG	P
1.50	2.50	1/2	10 <sup>†</sup>	0.38	0.44	1.75	1.50	0.42	1.63	3.44	4.25	4.63	2.88
2.00	3.00	1/2	10 <sup>†</sup>	0.63	0.56	1.75	1.50	0.57	2.05	4.13	5.13	4.63	2.88
2.50	3.50	1/2	10 <sup>†</sup>	0.63	0.56	1.75	1.50	0.57	2.55	4.63	5.63	4.75	3.00
3.25	4.50	3/4	12	0.75	0.69	2.00	1.75	0.68	3.25	5.88	7.13	5.50	3.50
4.00	5.00	3/4	12	0.88	0.69	2.00	1.75	0.68	3.82	6.38	7.63	5.75	3.75
5.00	6.50	3/4	12	0.88	0.94	2.00	1.75	0.94	4.95	8.19	9.75	6.25	4.25
6.00	7.50	1	16	1.00	1.06	2.25	2.25	1.05	5.73	9.44	11.25	7.38	4.88

<sup>1</sup>NPTF ports are available at no extra charge.

<sup>2</sup>SAE straight thread ports are standard and are indicated by port number.

<sup>†</sup>Previously number 8 SAE in 1.50 thru 2.50 bores now number 10 SAE.

**Style HB – Dimensional and Mounting Data**

Bore Ø	Rod No.	MM Rod Ø	WF	Y	Add Stroke	
					XF	ZF
1.50	1 (std.)	0.625	1.00	2.00	5.63	6.00
	2	1.000	1.38	2.38	6.00	6.38
2.00	1 (std.)	1.000	1.38	2.38	6.00	6.63
	2	1.375	1.63	2.63	6.25	6.88
2.50	1 (std.)	1.000	1.38	2.38	6.13	6.75
	2	1.750	1.88	2.88	6.63	7.25
	3	1.375	1.63	2.63	6.38	7.00
3.25	1 (std.)	1.375	1.63	2.75	7.13	7.88
	2	2.000	2.00	3.13	7.50	8.25
	3	1.750	1.88	3.00	7.38	8.13
4.00	1 (std.)	1.750	1.88	3.00	7.63	8.50
	2	2.500	2.25	3.38	8.00	8.88
	3	2.000	2.00	3.13	7.75	8.63
5.00	1 (std.)	2.000	2.00	3.13	8.25	9.13
	2	3.500	2.25	3.38	8.50	9.38
	3	2.500	2.25	3.38	8.50	9.38
	4	3.000	2.25	3.38	8.50	9.38
6.00	1 (std.)	2.500	2.25	3.50	9.63	10.63
	2	4.000	2.25	3.50	9.63	10.63
	3	3.000	2.25	3.50	9.63	10.63
	4	3.500	2.25	3.50	9.63	10.63

**⚠ PROP 65 WARNING** WARNING: This product can expose you to chemicals including **Lead and Lead Compounds** which are known to the State of California to cause cancer and birth defects or other reproductive harm. For more information go to [www.P65Warnings.ca.gov](http://www.P65Warnings.ca.gov)

**Cap Rectangular Flange Mounting**  
 Style HH  
 (NFPA Style ME6)

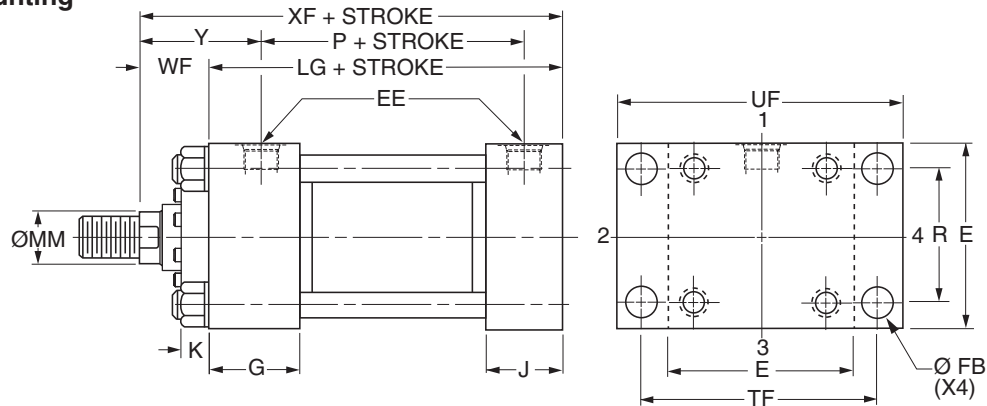
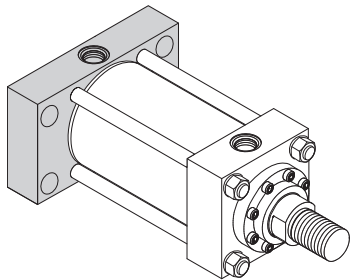

**Style HH – Dimensional and Mounting Data**

Bore Ø	E	EE		FB Ø	G	J	K Max.	R	TF	UF	Add Stroke	
		NPTF <sup>1</sup>	SAE <sup>2</sup>								LG	P
1.50	2.50	1/2	10 <sup>†</sup>	0.44	1.75	1.50	0.42	1.63	3.44	4.25	4.63	2.88
2.00	3.00	1/2	10 <sup>†</sup>	0.56	1.75	1.50	0.57	2.05	4.13	5.13	4.63	2.88
2.50	3.50	1/2	10 <sup>†</sup>	0.56	1.75	1.50	0.57	2.55	4.63	5.63	4.75	3.00
3.25	4.50	3/4	12	0.69	2.00	1.75	0.68	3.25	5.88	7.13	5.50	3.50
4.00	5.00	3/4	12	0.69	2.00	1.75	0.68	3.82	6.38	7.63	5.75	3.75
5.00	6.50	3/4	12	0.94	2.00	1.75	0.94	4.95	8.19	9.75	6.25	4.25
6.00	7.50	1	16	1.06	2.25	2.25	1.05	5.73	9.44	11.25	7.38	4.88

<sup>1</sup>NPTF ports are available at no extra charge.

<sup>2</sup>SAE straight thread ports are standard and are indicated by port number.

<sup>†</sup>Previously number 8 SAE in 1.50 thru 2.50 bores now number 10 SAE.

**Style HH – Dimensional and Mounting Data**

Bore Ø	Rod No.	MM Rod Ø	WF	Y	Add Stroke
					XF
1.50	1 (std.)	0.625	1.00	2.00	5.63
	2	1.000	1.38	2.38	6.00
2.00	1 (std.)	1.000	1.38	2.38	6.00
	2	1.375	1.63	2.63	6.25
2.50	1 (std.)	1.000	1.38	2.38	6.13
	2	1.750	1.88	2.88	6.63
	3	1.375	1.63	2.63	6.38
3.25	1 (std.)	1.375	1.63	2.75	7.13
	2	2.000	2.00	3.13	7.50
	3	1.750	1.88	3.00	7.38
4.00	1 (std.)	1.750	1.88	3.00	7.63
	2	2.500	2.25	3.38	8.00
	3	2.000	2.00	3.13	7.75
5.00	1 (std.)	2.000	2.00	3.13	8.25
	2	3.500	2.25	3.38	8.50
	3	2.500	2.25	3.38	8.50
	4	3.000	2.25	3.38	8.50
6.00	1 (std.)	2.500	2.25	3.50	9.63
	2	4.000	2.25	3.50	9.63
	3	3.000	2.25	3.50	9.63
	4	3.500	2.25	3.50	9.63

**⚠ PROP 65 WARNING** WARNING: This product can expose you to chemicals including **Lead and Lead Compounds** which are known to the State of California to cause cancer and birth defects or other reproductive harm. For more information go to [www.P65Warnings.ca.gov](http://www.P65Warnings.ca.gov)

PH Series  
 1.50" - 8.00" Bore

**Side Lug Mounting**

Style C  
(NFPA Style MS2)

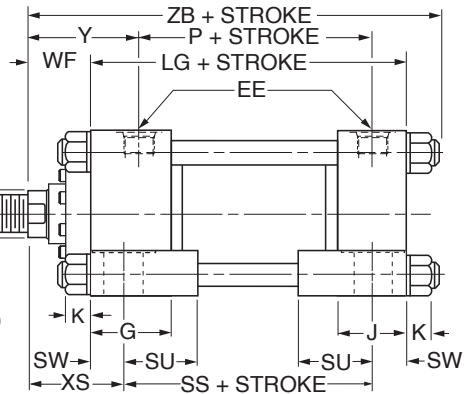
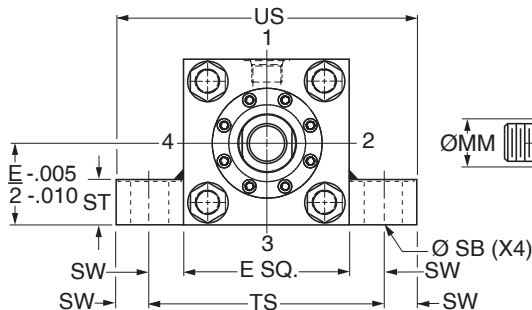
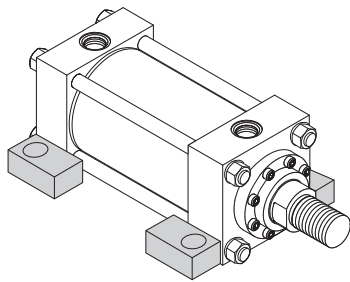

**Style C – Dimensional and Mounting Data**

Bore Ø	E	EE		G	J	K Max.	SB <sup>3</sup> Ø	ST	SU	SW	TS	US	Add Stroke		
		NPTF <sup>1</sup>	SAE <sup>2</sup>										LG	P	SS
1.50	2.50	1/2	10 <sup>†</sup>	1.75	1.50	0.42	0.44	0.50	0.94	0.38	3.25	4.00	4.63	2.88	3.88
2.00	3.00	1/2	10 <sup>†</sup>	1.75	1.50	0.57	0.56	0.75	1.25	0.50	4.00	5.00	4.63	2.88	3.63
2.50	3.50	1/2	10 <sup>†</sup>	1.75	1.50	0.57	0.81	1.00	1.56	0.69	4.88	6.25	4.75	3.00	3.38
3.25	4.50	3/4	12	2.00	1.75	0.68	0.81	1.00	1.56	0.69	5.88	7.25	5.50	3.50	4.13
4.00	5.00	3/4	12	2.00	1.75	0.68	1.06	1.25	2.00	0.88	6.75	8.50	5.75	3.75	4.00
5.00	6.50	3/4	12	2.00	1.75	0.94	1.06	1.25	2.00	0.88	8.25	10.00	6.25	4.25	4.50
6.00	7.50	1	16	2.25	2.25	1.05	1.31	1.50	2.50	1.13	9.75	12.00	7.38	4.88	5.13

<sup>1</sup>NPTF ports are available at no extra charge.

<sup>2</sup>SAE straight thread ports are standard and are indicated by port number.

<sup>3</sup>Upper surface spot faced for socket head screws.

<sup>†</sup>Previously number 8 SAE in 1.50 thru 2.50 bores now number 10 SAE.

**Style C – Dimensional and Mounting Data**

Bore Ø	Rod No.	MM Rod Ø	WF	XS	Y	Add Stroke
						ZB Max.
1.50	1 (std.)	0.625	1.00	1.38	2.00	6.29
	2	1.000	1.38	1.75	2.38	6.67
2.00	1 (std.)	1.000	1.38	1.88	2.38	6.81
	2	1.375	1.63	2.13	2.63	7.06
2.50	1 (std.)	1.000	1.38	2.06	2.38	6.93
	2	1.750	1.88	2.56	2.88	7.43
	3	1.375	1.63	2.31	2.63	7.18
3.25	1 (std.)	1.375	1.63	2.31	2.75	8.06
	2	2.000	2.00	2.69	3.13	8.43
	3	1.750	1.88	2.56	3.00	8.31
4.00	1 (std.)	1.750	1.88	2.75	3.00	8.56
	2	2.500	2.25	3.13	3.38	8.94
	3	2.000	2.00	2.88	3.13	8.68
5.00	1 (std.)	2.000	2.00	2.88	3.13	9.44
	2	3.500	2.25	3.13	3.38	9.69
	3	2.500	2.25	3.13	3.38	9.69
	4	3.000	2.25	3.13	3.38	9.69
6.00	1 (std.)	2.500	2.25	3.38	3.50	10.93
	2	4.000	2.25	3.38	3.50	10.93
	3	3.000	2.25	3.38	3.50	10.93
	4	3.500	2.25	3.38	3.50	10.93

**PH Series**  
**1.50" - 8.00" Bore**



**PROP 65 WARNING** WARNING: This product can expose you to chemicals including **Lead and Lead Compounds** which are known to the State of California to cause cancer and birth defects or other reproductive harm. For more information go to [www.P65Warnings.ca.gov](http://www.P65Warnings.ca.gov)

**Side Tapped Mounting**  
 Style F  
 (NFPA Style MS4)

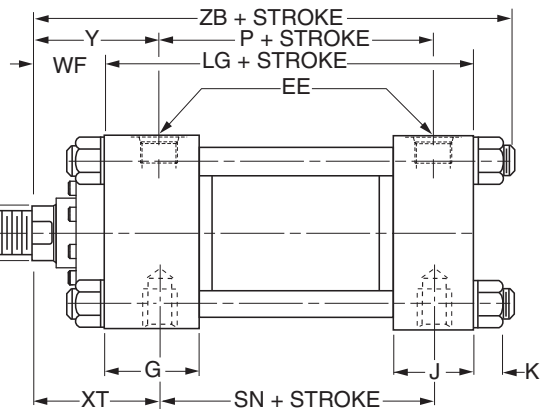
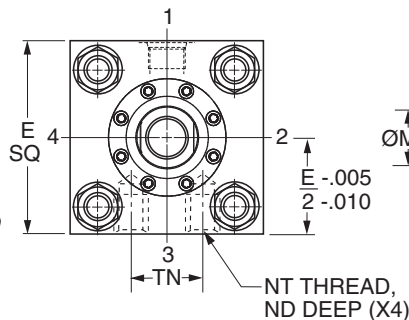
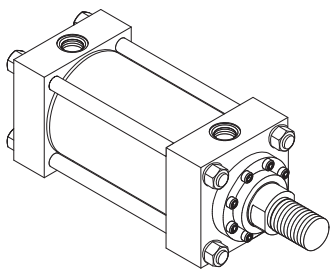

**Style F – Dimensional and Mounting Data**

Bore Ø	E	EE		G	J	K Max.	ND	NT	TN	Add Stroke		
		NPTF <sup>1</sup>	SAE <sup>2</sup>							LG	P	SN
1.50	2.50	1/2	10 <sup>†</sup>	1.75	1.50	0.42	0.38	3/8-16	0.75	4.63	2.88	2.88
2.00	3.00	1/2	10 <sup>†</sup>	1.75	1.50	0.57	0.44	1/2-13	0.94	4.63	2.88	2.88
2.50	3.50	1/2	10 <sup>†</sup>	1.75	1.50	0.57	0.50	5/8-11	1.31	4.75	3.00	3.00
3.25	4.50	3/4	12	2.00	1.75	0.68	0.69	3/4-10	1.50	5.50	3.50	3.50
4.00	5.00	3/4	12	2.00	1.75	0.68	0.69	1-8	2.06	5.75	3.75	3.75
5.00	6.50	3/4	12	2.00	1.75	0.94	1.00	1-8	2.94	6.25	4.25	4.25
6.00	7.50	1	16	2.25	2.25	1.05	1.25	1 1/4 -7	3.31	7.38	4.88	5.13

<sup>1</sup>NPTF ports are available at no extra charge.

<sup>2</sup>SAE straight thread ports are standard and are indicated by port number.

<sup>†</sup>Previously number 8 SAE in 1.50 thru 2.50 bores now number 10 SAE.

**Style F – Dimensional and Mounting Data**

Bore Ø	Rod No.	MM Rod Ø	WF	XT	Y	Add Stroke
						ZB Max.
1.50	1 (std.)	0.625	1.00	2.00	2.00	6.29
	2	1.000	1.38	2.38	2.38	6.67
2.00	1 (std.)	1.000	1.38	2.38	2.38	6.81
	2	1.375	1.63	2.63	2.63	7.06
2.50	1 (std.)	1.000	1.38	2.38	2.38	6.93
	2	1.750	1.88	2.88	2.88	7.43
	3	1.375	1.63	2.63	2.63	7.18
3.25	1 (std.)	1.375	1.63	2.75	2.75	8.06
	2	2.000	2.00	3.13	3.13	8.43
	3	1.750	1.88	3.00	3.00	8.31
4.00	1 (std.)	1.750	1.88	3.00	3.00	8.56
	2	2.500	2.25	3.38	3.38	8.94
	3	2.000	2.00	3.13	3.13	8.68
5.00	1 (std.)	2.000	2.00	3.13	3.13	9.44
	2	3.500	2.25	3.38	3.38	9.69
	3	2.500	2.25	3.38	3.38	9.69
	4	3.000	2.25	3.38	3.38	9.69
6.00	1 (std.)	2.500	2.25	3.50	3.50	10.93
	2	4.000	2.25	3.50	3.50	10.93
	3	3.000	2.25	3.50	3.50	10.93
	4	3.500	2.25	3.50	3.50	10.93

**⚠ PROP 65 WARNING** WARNING: This product can expose you to chemicals including **Lead and Lead Compounds** which are known to the State of California to cause cancer and birth defects or other reproductive harm. For more information go to [www.P65Warnings.ca.gov](http://www.P65Warnings.ca.gov)

PH Series  
1.50" - 8.00" Bore

**Cap Fixed Clevis Mounting**  
 Style BB  
 (NFPA Style MP1)

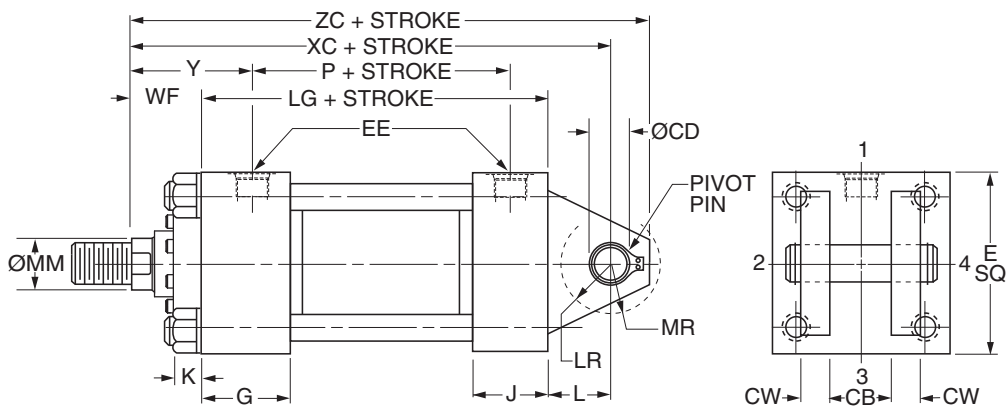
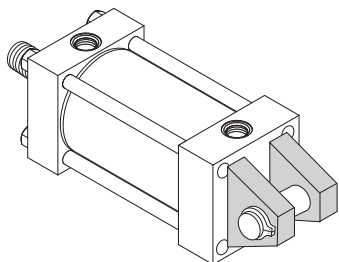

**Style BB – Dimensional and Mounting Data**

Bore Ø	E	EE		CB	CD <sup>3</sup> Ø +-.000 -.002	CW	G	J	K Max.	L	LR	MR	Add Stroke	
		NPTF <sup>1</sup>	SAE <sup>2</sup>										LG	P
1.50	2.50	1/2	10 <sup>†</sup>	0.75	.501	0.50	1.75	1.50	0.42	0.75	0.56	0.63	4.63	2.88
2.00	3.00	1/2	10 <sup>†</sup>	1.25	.751	0.63	1.75	1.50	0.57	1.25	1.00	0.94	4.63	2.88
2.50	3.50	1/2	10 <sup>†</sup>	1.25	.751	0.63	1.75	1.50	0.57	1.25	0.94	0.94	4.75	3.00
3.25	4.50	3/4	12	1.50	1.001	0.75	2.00	1.75	0.68	1.50	1.25	1.19	5.50	3.50
4.00	5.00	3/4	12	2.00	1.376	1.00	2.00	1.75	0.68	2.13	1.75	1.63	5.75	3.75
5.00	6.50	3/4	12	2.50	1.751	1.25	2.00	1.75	0.94	2.25	2.06	2.13	6.25	4.25
6.00	7.50	1	16	2.50	2.001	1.25	2.25	2.25	1.05	2.50	2.31	2.38	7.38	4.88

<sup>1</sup>NPTF ports are available at no extra charge.

<sup>2</sup>SAE straight thread ports are standard and are indicated by port number.

<sup>3</sup>Diameter CD is Pin Diameter.

<sup>†</sup>Previously number 8 SAE in 1.50 thru 2.50 bores now number 10 SAE.

**Style BB – Dimensional and Mounting Data**

Bore Ø	Rod No.	MM Rod Ø	WF	Y	Add Stroke	
					XC	ZC
1.50	1 (std.)	0.625	1.00	2.00	6.38	6.88
	2	1.000	1.38	2.38	6.75	7.25
2.00	1 (std.)	1.000	1.38	2.38	7.25	8.00
	2	1.375	1.63	2.63	7.50	8.25
2.50	1 (std.)	1.000	1.38	2.38	7.38	8.13
	2	1.750	1.88	2.88	7.88	8.63
	3	1.375	1.63	2.63	7.63	8.38
3.25	1 (std.)	1.375	1.63	2.75	8.63	9.63
	2	2.000	2.00	3.13	9.00	10.00
	3	1.750	1.88	3.00	8.88	9.88
4.00	1 (std.)	1.750	1.88	3.00	9.75	11.13
	2	2.500	2.25	3.38	10.13	11.50
	3	2.000	2.00	3.13	9.88	11.25
5.00	1 (std.)	2.000	2.00	3.13	10.50	12.25
	2	3.500	2.25	3.38	10.75	12.50
	3	2.500	2.25	3.38	10.75	12.50
	4	3.000	2.25	3.38	10.75	12.50
6.00	1 (std.)	2.500	2.25	3.50	12.13	14.13
	2	4.000	2.25	3.50	12.13	14.13
	3	3.000	2.25	3.50	12.13	14.13
	4	3.500	2.25	3.50	12.13	14.13

**⚠ PROP 65 WARNING** WARNING: This product can expose you to chemicals including **Lead and Lead Compounds** which are known to the State of California to cause cancer and birth defects or other reproductive harm. For more information go to [www.P65Warnings.ca.gov](http://www.P65Warnings.ca.gov)

**Head Trunnion Mounting**  
**Style D**  
(NFPA Style MT1)

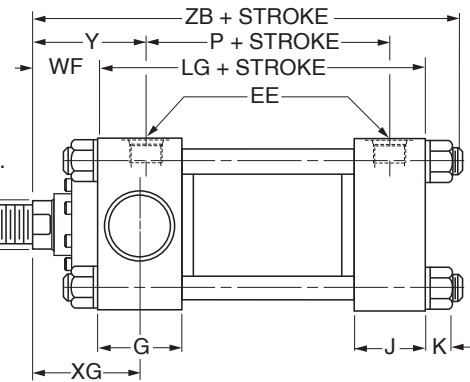
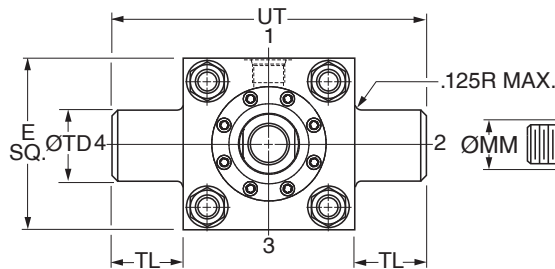
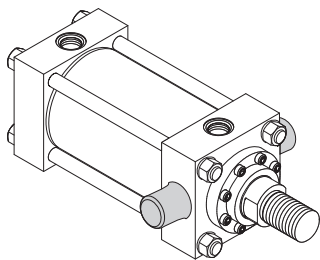

**Style D – Dimensional and Mounting Data**

Bore Ø	E	EE		G	J	K Max.	TD Ø +.000 -0.001	TL	UT	Add Stroke	
		NPTF <sup>1</sup>	SAE <sup>2</sup>							LG	P
1.50	2.50	1/2	10 <sup>†</sup>	1.75	1.50	0.42	1.000	1.00	4.50	4.63	2.88
2.00	3.00	1/2	10 <sup>†</sup>	1.75	1.50	0.57	1.375	1.38	5.75	4.63	2.88
2.50	3.50	1/2	10 <sup>†</sup>	1.75	1.50	0.57	1.375	1.38	6.25	4.75	3.00
3.25	4.50	3/4	12	2.00	1.75	0.68	1.750	1.75	8.00	5.50	3.50
4.00	5.00	3/4	12	2.00	1.75	0.68	1.750	1.75	8.50	5.75	3.75
5.00	6.50	3/4	12	2.00	1.75	0.94	1.750	1.75	10.00	6.25	4.25
6.00	7.50	1	16	2.25	2.25	1.05	2.000	2.00	11.50	7.38	4.88

<sup>1</sup>NPTF ports are available at no extra charge.

<sup>2</sup>SAE straight thread ports are standard and are indicated by port number.

<sup>†</sup>Previously number 8 SAE in 1.50 thru 2.50 bores now number 10 SAE.

**Style D – Dimensional and Mounting Data**

Bore Ø	Rod No.	MM Rod Ø	WF	XG	Y	Add Stroke
						ZB Max.
1.50	1 (std.)	0.625	1.00	1.88	2.00	6.29
	2	1.000	1.38	2.25	2.38	6.67
2.00	1 (std.)	1.000	1.38	2.25	2.38	6.81
	2	1.375	1.63	2.50	2.63	7.06
2.50	1 (std.)	1.000	1.38	2.25	2.38	6.93
	2	1.750	1.88	2.75	2.88	7.43
	3	1.375	1.63	2.50	2.63	7.18
3.25	1 (std.)	1.375	1.63	2.63	2.75	8.06
	2	2.000	2.00	3.00	3.13	8.43
	3	1.750	1.88	2.88	3.00	8.31
4.00	1 (std.)	1.750	1.88	2.88	3.00	8.56
	2	2.500	2.25	3.25	3.38	8.94
	3	2.000	2.00	3.00	3.13	8.68
5.00	1 (std.)	2.000	2.00	3.00	3.13	9.44
	2	3.500	2.25	3.25	3.38	9.69
	3	2.500	2.25	3.25	3.38	9.69
	4	3.000	2.25	3.25	3.38	9.69
6.00	1 (std.)	2.500	2.25	3.38	3.50	10.93
	2	4.000	2.25	3.38	3.50	10.93
	3	3.000	2.25	3.38	3.50	10.93
	4	3.500	2.25	3.38	3.50	10.93

**⚠ PROP 65 WARNING** WARNING: This product can expose you to chemicals including **Lead and Lead Compounds** which are known to the State of California to cause cancer and birth defects or other reproductive harm. For more information go to [www.P65Warnings.ca.gov](http://www.P65Warnings.ca.gov)

PH Series  
1.50" - 8.00" Bore

**Cap Trunnion Mounting**  
 Style DB  
 (NFPA Style MT2)

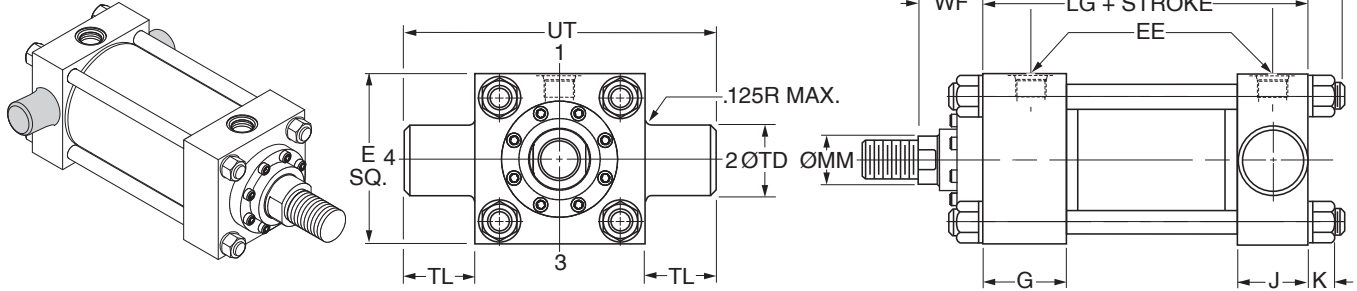

**Style DB – Dimensional and Mounting Data**

Bore Ø	E	EE		G	J	K Max.	TD Ø +.000 -0.001	TL	UT	Add Stroke	
		NPTF <sup>1</sup>	SAE <sup>2</sup>							LG	P
1.50	2.50	1/2	10 <sup>3</sup>	1.75	1.50	0.42	1.000	1.00	4.50	4.63	2.88
2.00	3.00	1/2	10 <sup>3</sup>	1.75	1.50	0.57	1.375	1.38	5.75	4.63	2.88
2.50	3.50	1/2	10 <sup>3</sup>	1.75	1.50	0.57	1.375	1.38	6.25	4.75	3.00
3.25	4.50	3/4	12	2.00	1.75	0.68	1.750	1.75	8.00	5.50	3.50
4.00	5.00	3/4	12	2.00	1.75	0.68	1.750	1.75	8.50	5.75	3.75
5.00	6.50	3/4	12	2.00	1.75	0.94	1.750	1.75	10.00	6.25	4.25
6.00	7.50	1	16	2.25	2.25	1.05	2.000	2.00	11.50	7.38	4.88

<sup>1</sup>NPTF ports are available at no extra charge.

<sup>2</sup>SAE straight thread ports are standard and are indicated by port number.

<sup>3</sup>Previously number 8 SAE in 1.50 thru 2.50 bores now number 10 SAE.

**Style DB – Dimensional and Mounting Data**

Bore Ø	Rod No.	MM Rod Ø	WF	Y	Add Stroke	
					XJ	ZB Max.
1.50	1 (std.)	0.625	1.00	2.00	4.88	6.29
	2	1.000	1.38	2.38	5.25	6.67
2.00	1 (std.)	1.000	1.38	2.38	5.25	6.81
	2	1.375	1.63	2.63	5.50	7.06
2.50	1 (std.)	1.000	1.38	2.38	5.38	6.93
	2	1.750	1.88	2.88	5.88	7.43
	3	1.375	1.63	2.63	5.63	7.18
3.25	1 (std.)	1.375	1.63	2.75	6.25	8.06
	2	2.000	2.00	3.13	6.63	8.43
	3	1.750	1.88	3.00	6.50	8.31
4.00	1 (std.)	1.750	1.88	3.00	6.75	8.56
	2	2.500	2.25	3.38	7.13	8.94
	3	2.000	2.00	3.13	6.88	8.68
5.00	1 (std.)	2.000	2.00	3.13	7.38	9.44
	2	3.500	2.25	3.38	7.63	9.69
	3	2.500	2.25	3.38	7.63	9.69
	4	3.000	2.25	3.38	7.63	9.69
6.00	1 (std.)	2.500	2.25	3.50	8.38	10.93
	2	4.000	2.25	3.50	8.38	10.93
	3	3.000	2.25	3.50	8.38	10.93
	4	3.500	2.25	3.50	8.38	10.93

**B**  
 PH Series  
 1.50" - 8.00" Bore

**⚠ PROP 65 WARNING** WARNING: This product can expose you to chemicals including **Lead and Lead Compounds** which are known to the State of California to cause cancer and birth defects or other reproductive harm. For more information go to [www.P65Warnings.ca.gov](http://www.P65Warnings.ca.gov)

**Intermediate Fixed Trunnion Mounting**

Style DD  
 (NFPA Style MT4)

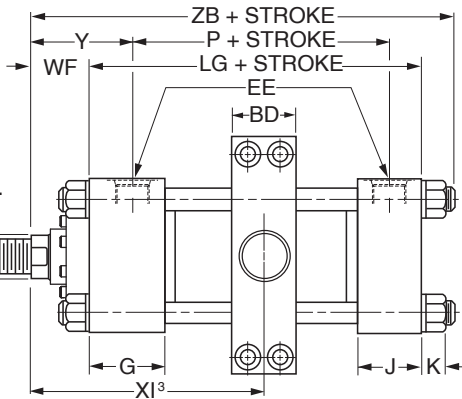
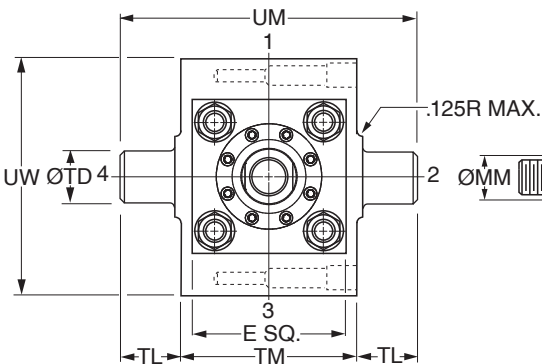
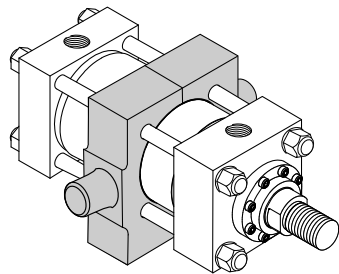

**Style DD (Model 89) – Dimensional and Mounting Data**

Bore Ø	BD	E	EE		G	J	K Max.	TD Ø +0.000 -0.001	TL	TM	UM	UW	Add Stroke	
			NPTF <sup>1</sup>	SAE <sup>2</sup>									LG	P
1.50	1.25	2.50	1/2	10 <sup>1</sup>	1.75	1.50	0.42	1.000	1.00	3.00	5.00	3.38	4.63	2.88
2.00	1.50	3.00	1/2	10 <sup>1</sup>	1.75	1.50	0.57	1.375	1.38	3.50	6.25	4.13	4.63	2.88
2.50	1.50	3.50	1/2	10 <sup>1</sup>	1.75	1.50	0.57	1.375	1.38	4.00	6.75	4.63	4.75	3.00
3.25	2.00	4.50	3/4	12	2.00	1.75	0.68	1.750	1.75	5.00	8.50	5.81	5.50	3.50
4.00	2.00	5.00	3/4	12	2.00	1.75	0.68	1.750	1.75	5.50	9.00	6.38	5.75	3.75
5.00	2.00	6.50	3/4	12	2.00	1.75	0.94	1.750	1.75	7.00	10.50	7.75	6.25	4.25
6.00	3.00	7.50	1	16	2.25	2.25	1.05	2.000	2.00	8.50	12.50	10.38	7.38	4.88

<sup>1</sup>NPTF ports are available at no extra charge.

<sup>2</sup>SAE straight thread ports are standard and are indicated by port number.

<sup>3</sup>Previously number 8 SAE in 1.50 thru 2.50 bores now number 10 SAE.

**Style DD – Dimensional and Mounting Data**

Bore Ø	Rod No.	MM Rod Ø	WF	Y	Minimum XI <sup>3</sup>		Style DD Min. Stroke	Add Stroke		ZB Max
					Styles 4, 8 & 9	Style 55		Maximum XI <sup>4</sup>		
								Styles 4, 8 & 9	Style 55	
1.50	1 (std.)	0.625	1.00	2.00	3.44	4.19	0	3.44	4.19	6.29
	2	1.000	1.38	2.38	3.81	4.81	0	3.81	4.81	6.67
2.00	1 (std.)	1.000	1.38	2.38	3.94	4.94	0.25	3.69	4.69	6.81
	2	1.375	1.63	2.63	4.19	5.31	0.25	3.94	5.06	7.06
2.50	1 (std.)	1.000	1.38	2.38	3.94	4.94	0.13	3.81	4.81	6.93
	2	1.750	1.88	2.88	4.44	5.69	0.13	4.31	5.56	7.43
	3	1.375	1.63	2.63	4.19	5.31	0.13	4.06	5.19	7.18
3.25	1 (std.)	1.375	1.63	2.75	4.69	5.81	0.38	4.31	5.44	8.06
	2	2.000	2.00	3.13	5.06	6.81	0.38	4.69	6.44	8.43
	3	1.750	1.88	3.00	4.94	6.19	0.38	4.56	5.81	8.31
4.00	1 (std.)	1.750	1.88	3.00	4.94	6.19	0.13	4.81	6.06	8.56
	2	2.500	2.25	3.38	5.31	7.56	0.13	5.19	7.44	8.94
	3	2.000	2.00	3.13	5.06	6.81	0.13	4.94	6.69	8.68
5.00	1 (std.)	2.000	2.00	3.13	5.06	6.81	0	5.44	7.19	9.44
	2	3.500	2.25	3.38	5.31	8.69	0	5.69	9.06	9.69
	3	2.500	2.25	3.38	5.31	7.56	0	5.69	7.94	9.69
	4	3.000	2.25	3.38	5.31	7.94	0	5.69	8.31	9.69
6.00	1 (std.)	2.500	2.25	3.50	6.06	8.31	0.25	5.81	8.06	10.93
	2	4.000	2.25	3.50	6.06	9.56	0.25	5.81	9.31	10.93
	3	3.000	2.25	3.50	6.06	8.69	0.25	5.81	8.44	10.93
	4	3.500	2.25	3.50	6.06	9.44	0.25	5.81	9.19	10.93

<sup>3</sup>Dimension XI to be specified by customer. Reference point for rod end Style 55 is end of piston rod.

<sup>4</sup>Dimensions shown are valid for standard WF and WG dimension.

**⚠ PROP 65 WARNING** WARNING: This product can expose you to chemicals including **Lead and Lead Compounds** which are known to the State of California to cause cancer and birth defects or other reproductive harm. For more information go to [www.P65Warnings.ca.gov](http://www.P65Warnings.ca.gov)

PH Series  
 1.50" - 8.00" Bore



**Heavy Duty Intermediate Fixed Trunnion Mounting**  
 Style DE  
 (NFPA Style MT4)

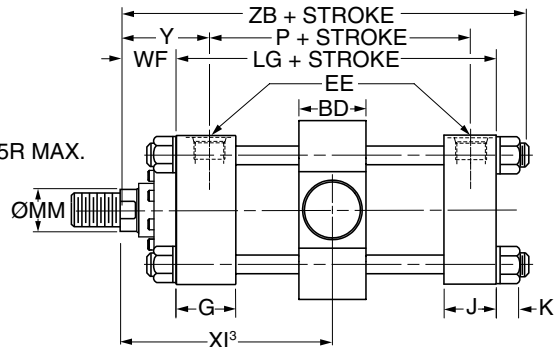
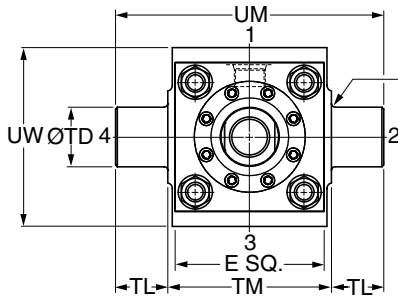
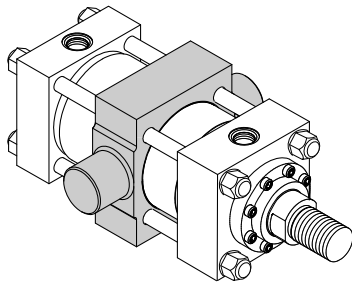

**Style DE – Dimensional and Mounting Data**

Bore Ø	BD	E	EE		G	J	K Max.	TD Ø +0.001 -0.001	TL	TM	UM	UW	Add Stroke	
			NPTF <sup>1</sup>	SAE <sup>2</sup>									LG	P
4.00	2.25	5.00	3/4	12	2.00	1.75	0.68	2.000	1.75	5.50	9.00	6.00	5.75	3.75
5.00	2.75	6.50	3/4	12	2.00	1.75	0.94	2.500	1.75	7.00	10.50	7.50	6.25	4.25
6.00	3.25	7.50	1	16	2.25	2.25	1.05	3.000	2.00	8.50	12.50	9.50	7.38	4.88

<sup>1</sup>NPTF ports are available at no extra charge.

<sup>2</sup>SAE straight thread ports are standard and are indicated by port number.

**Style DE – Dimensional and Mounting Data**

Bore Ø	Rod No.	MM Rod Ø	WF	Y	Minimum XI <sup>3</sup>		Style DE Minimum Stroke	Add Stroke		
					Styles 4, 8 & 9	Style 55		Maximum XI <sup>4</sup>		ZB Max.
								Styles 4, 8 & 9	Style 55	
4.00	1 (std.)	1.750	1.88	3.00	5.06	6.31	0.38	4.69	5.94	8.56
	2	2.500	2.25	3.38	5.44	7.69	0.38	5.06	7.31	8.94
	3	2.000	2.00	3.13	5.19	6.94	0.38	4.81	6.56	8.68
5.00	1 (std.)	2.000	2.00	3.13	5.44	7.19	0.38	5.06	6.81	9.44
	2	3.500	2.25	3.38	5.69	9.06	0.38	5.31	8.69	9.69
	3	2.500	2.25	3.38	5.69	7.94	0.38	5.31	7.56	9.69
	4	3.000	2.25	3.38	5.69	8.31	0.38	5.31	7.94	9.69
6.00	1 (std.)	2.500	2.25	3.50	6.19	8.44	0.50	5.69	7.94	10.93
	2	4.000	2.25	3.50	6.19	9.69	0.50	5.69	9.19	10.93
	3	3.000	2.25	3.50	6.19	8.81	0.50	5.69	8.31	10.93
	4	3.500	2.25	3.50	6.19	9.56	0.50	5.69	9.06	10.93

<sup>3</sup>Dimension XI to be specified by customer. Reference point for rod end Style 55 is end of piston rod.

<sup>4</sup>Dimensions shown are valid for standard WF and WG dimension.



**PROP 65 WARNING**

WARNING: This product can expose you to chemicals including **Lead and Lead Compounds** which are known to the State of California to cause cancer and birth defects or other reproductive harm. For more information go to [www.P65Warnings.ca.gov](http://www.P65Warnings.ca.gov)

**Spherical Bearing Mounting**  
**Style SB**

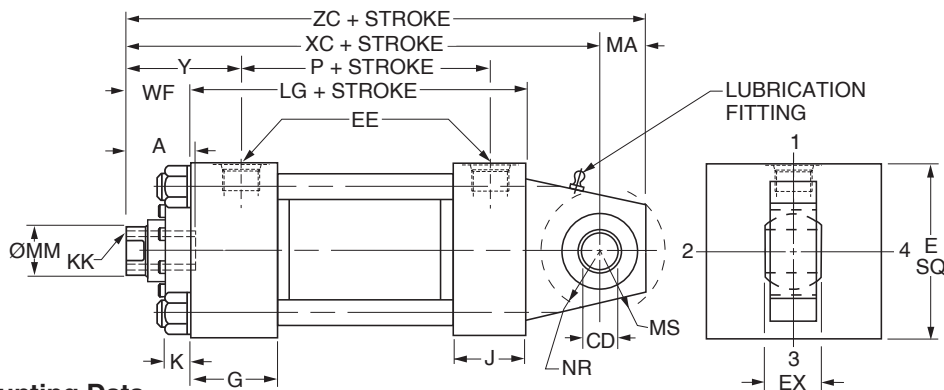
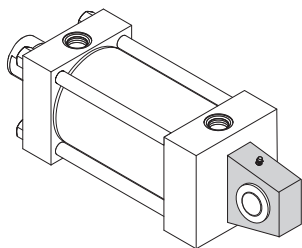

**Style SB – Dimensional and Mounting Data**

Bore Ø	A	CD <sup>1</sup> Ø +0.0000 -0.0005	E	EE		EX	G	J	K Max.	MA	MS	NR	Add Stroke		Maximum Operating psi <sup>2</sup>
				NPTF <sup>4</sup>	SAE <sup>5</sup>								LG	P	
1.50	0.75	0.5000	2.50	1/2	10 <sup>†</sup>	0.44	1.75	1.50	0.42	0.75	0.94	0.63	4.63	2.88	1500
2.00	1.13	0.7500	3.00	1/2	10 <sup>†</sup>	0.66	1.75	1.50	0.57	1.00	1.38	1.00	4.63	2.88	2200
2.50	1.13	0.7500	3.50	1/2	10 <sup>†</sup>	0.66	1.75	1.50	0.57	1.00	1.38	1.00	4.75	3.00	1450
3.25	1.63	1.0000	4.50	3/4	12	0.88	2.00	1.75	0.68	1.25	1.69	1.25	5.50	3.50	1500
4.00	2.00	1.3750	5.00	3/4	12	1.19	2.00	1.75	0.68	1.88	2.44	1.63	5.75	3.75	1850
5.00	2.25	1.7500	6.50	3/4	12	1.53	2.00	1.75	0.94	2.50	2.88	2.06	6.25	4.25	2000
6.00	3.00	2.0000	7.50	1	16	1.75	2.25	2.25	1.05 <sup>3</sup>	2.50	3.31	2.38	7.38	4.88	1800

<sup>1</sup> Diameter CD is hole diameter.

<sup>4</sup>NPTF ports are available at no extra charge.

<sup>2</sup> Maximum operating pressure at 4:1 design factor is based on tensile strength of material.

<sup>5</sup>SAE straight thread ports are standard and are indicated by port number.

Pressure ratings are based on standard bearing ratings.

<sup>†</sup>Previously number 8 SAE in 1.50 thru 2.50 bores now number 10 SAE.

<sup>3</sup> 6.00" bore is constructed with tie rod nuts on both ends.

**Style SB – Dimensional and Mounting Data**

Bore Ø	Rod No.	MM Rod Ø	Thread		WF	Y	Add Stroke		
			Style 9 KK <sup>6</sup>	Style 7 KK <sup>6</sup>			XC	XL	ZC
1.50	1 (std.)	0.625	7/16-20	—	1.00	2.00	6.38	7.25	7.13
	2	1.000	—	7/16-20	1.38	2.38	6.75	7.63	7.50
2.00	1 (std.)	1.000	3/4-16	—	1.38	2.38	7.25	8.50	8.25
	2	1.375	—	3/4-16	1.63	2.63	7.50	8.75	8.50
2.50	1 (std.)	1.000	3/4-16	—	1.38	2.38	7.38	8.63	8.38
	2	1.750	—	3/4-16	1.88	2.88	7.88	9.13	8.88
	3	1.375	—	3/4-16	1.63	2.63	7.63	8.88	8.63
3.25	1 (std.)	1.375	1-14	—	1.63	2.75	8.63	10.50	9.88
	2	2.000	—	1-14	2.00	3.13	9.00	10.88	10.25
	3	1.750	—	1-14	1.88	3.00	8.88	10.75	10.13
4.00	1 (std.)	1.750	1 1/4-12	—	1.88	3.00	9.75	11.88	11.63
	2	2.500	—	1 1/4-12	2.25	3.38	10.13	12.25	12.00
	3	2.000	—	1 1/4-12	2.00	3.13	9.88	12.00	11.75
5.00	1 (std.)	2.000	1 1/2-12	—	2.00	3.13	10.50	13.00	13.00
	2	3.500	—	1 1/2-12	2.25	3.38	10.75	13.25	13.25
	3	2.500	—	1 1/2-12	2.25	3.38	10.75	13.25	13.25
	4	3.000	—	1 1/2-12	2.25	3.38	10.75	13.25	13.25
6.00	1 (std.)	2.500	1 7/8-12	—	2.25	3.50	12.13	14.88	14.63
	2	4.000	—	1 7/8-12	2.25	3.50	12.13	14.88	14.63
	3	3.000	—	1 7/8-12	2.25	3.50	12.13	14.88	14.63
	4	3.500	—	1 7/8-12	2.25	3.50	12.13	14.88	14.63

<sup>6</sup> Style 9 and Style 7 threads listed are for a spherical rod eye (sold separately) with pin diameter that matches the cap pin.

**Style SB – Recommended maximum swivel angle on each side of the cylinder centerline.**

Bore Ø	Head End Mounted		Cap End Mounted	
	Angle a	Tan. of a	Angle a	Tan. of a
1.50	2.00°	.035	2.00°	.035
2.00	2.50°	.044	4.50°	.079
2.50	2.50°	.044	4.50°	.079
3.25	3.00°	.052	3.00°	.052
4.00	2.50°	.044	3.00°	.052
5.00	3.00°	.052	3.00°	.052
6.00	3.00°	.052	3.00°	.052

Note: Dimension X is the maximum off center mounting of the cylinder. To determine dimension X for various stroke lengths multiply the distance between pivot pin holes by tangent of angle a. For extended position use X = XL + 2X stroke.

**Mounting Information**

**Head End Mounting**

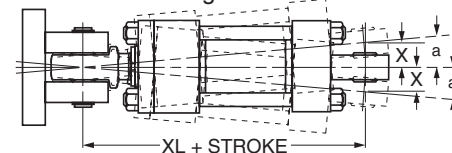

**Cap End Mounting**

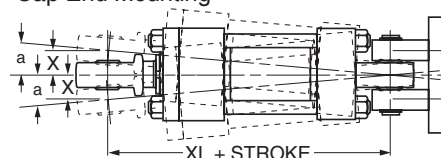

**⚠ PROP 65 WARNING** WARNING: This product can expose you to chemicals including **Lead and Lead Compounds** which are known to the State of California to cause cancer and birth defects or other reproductive harm. For more information go to [www.P65Warnings.ca.gov](http://www.P65Warnings.ca.gov)

PH Series  
 1.50" - 8.00" Bore

**Spherical Bearing Mounting**  
**Style SE**

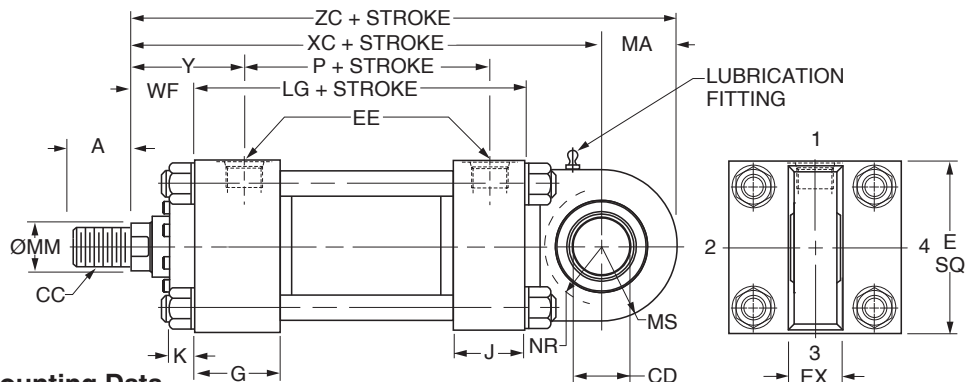
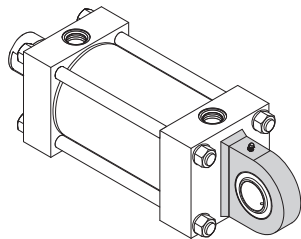

**Style SE – Dimensional and Mounting Data**

Bore Ø	A	CD <sup>1</sup> Ø +0.0000 -0.0005	E	EE		EX	G	J	K Max.	MA	MS	NR	Add Stroke	
				NPTF <sup>3</sup>	SAE <sup>4</sup>								LG	P
1.50	0.75	0.7500	2.50	1/2	10 <sup>†</sup>	0.66	1.75	1.50	0.42	1.00	1.00	0.75	4.63	2.88
2.00	1.13	1.0000	3.00	1/2	10 <sup>†</sup>	0.88	1.75	1.50	0.57	1.25	1.25	1.00	4.63	2.88
2.50	1.13	1.2500	3.50	1/2	10 <sup>†</sup>	1.09	1.75	1.50	0.57	1.50	1.50	1.31	4.75	3.00
3.25	1.63	1.5000	4.50	3/4	12	1.31	2.00	1.75	0.68	2.00	2.00	1.75	5.50	3.50
4.00	2.00	2.0000	5.00	3/4	12	1.75	2.00	1.75	0.68	2.25	2.25	2.13	5.75	3.75
5.00	2.25	2.5000	6.50	3/4	12	2.19	2.00	1.75	0.94	3.00	3.00	2.75	6.25	4.25
6.00	3.00	3.0000	7.50	1	16	2.63	2.25	2.25	1.05	3.50	3.50	3.13	7.38	4.88

<sup>1</sup> Diameter CD is hole diameter.

<sup>†</sup> Previously number 8 SAE in 1.50 thru 2.50 bores now number 10 SAE.

<sup>2</sup> 6.00" bore is constructed with tie rod nuts on both ends.

<sup>3</sup> NPTF ports are available at no extra charge.

<sup>4</sup> SAE straight thread ports are standard and are indicated by port number.

**Style SE – Dimensional and Mounting Data**

Bore Ø	Rod No.	MM Rod Ø	Thread Style 8 CC <sup>5</sup>	A	WF	Y	Add Stroke		
							XC	XL	ZC
1.50	1 (std.)	0.625	1/2-20	0.75	1.00	2.00	6.88	9.01	7.88
	2	1.000	5	5	1.38	2.38	7.25	9.38	8.25
2.00	1 (std.)	1.000	7/8-14	1.13	1.38	2.38	7.56	10.56	8.81
	2	1.375	5	5	1.63	2.63	7.81	10.81	9.06
2.50	1 (std.)	1.000	7/8-14	1.13	1.38	2.38	7.75	10.75	9.25
	2	1.750	5	5	1.88	2.88	8.25	11.25	9.75
	3	1.375	5	5	1.63	2.63	8.00	11.00	9.50
3.25	1 (std.)	1.375	1 1/4-12	1.63	1.63	2.75	9.25	13.38	11.25
	2	2.000	5	5	2.00	3.13	9.63	13.75	11.63
	3	1.750	5	5	1.88	3.00	9.50	13.63	11.50
4.00	1 (std.)	1.750	1 1/2-12	2.00	1.88	3.00	10.13	15.13	12.38
	2	2.500	5	5	2.25	3.38	10.50	15.50	12.75
	3	2.000	5	5	2.00	3.13	10.25	15.25	12.50
5.00	1 (std.)	2.000	1 3/4-12	2.25	2.00	3.13	11.50	17.25	14.50
	2	3.500	5	5	2.25	3.38	11.75	17.50	14.75
	3	2.500	5	5	2.25	3.38	11.75	17.50	14.75
6.00	1 (std.)	2.500	2 1/4-12	3.00	2.25	3.50	13.38	20.38	16.88
	2	4.000	5	5	2.25	3.50	13.38	20.38	16.88
	3	3.000	5	5	2.25	3.50	13.38	20.38	16.88
	4	3.500	5	5	2.25	3.50	13.38	20.38	16.88

<sup>5</sup> To match pin diameter in rod eye and cap, when an oversize rod is required, specify rod end style '3', 'CC' thread and 'A' thread length for the standard rod diameter (Rod No. 1 for the bore), and 'WF' for the oversize rod. Order the rod eye and clevis bracket for the required bore size from the tables on the Style SE Spherical Bearing Accessories page.

**Style SE – Recommended maximum swivel angle on each side of the cylinder centerline.**

Bore Ø	Head End Mounted		Cap End Mounted	
	Angle a	Tan. of a	Angle a	Tan. of a
1.50	2.50°	0.044	3.00°	0.052
2.00	3.00°	0.052	3.00°	0.052
2.50	3.00°	0.052	3.00°	0.052
3.25	3.00°	0.052	2.75°	0.048
4.00	3.00°	0.052	3.00°	0.052
5.00	3.00°	0.052	3.00°	0.052
6.00	3.00°	0.052	3.00°	0.052

Note: Dimension X is the maximum off center mounting of the cylinder. To determine dimension X for various stroke lengths multiply the distance between pivot pin holes by tangent of angle a. For extended position use X = XL + 2X stroke.

**Mounting Information**

**Head End Mounting**

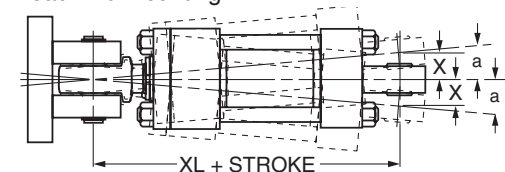

**Cap End Mounting**

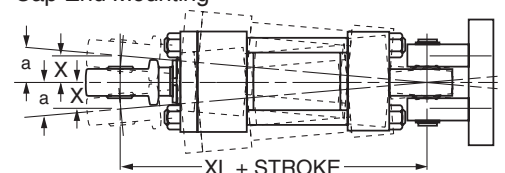

**PROP 65 WARNING** WARNING: This product can expose you to chemicals including **Lead and Lead Compounds** which are known to the State of California to cause cancer and birth defects or other reproductive harm. For more information go to [www.P65Warnings.ca.gov](http://www.P65Warnings.ca.gov)

**Double Rod Cylinder  
Style K**

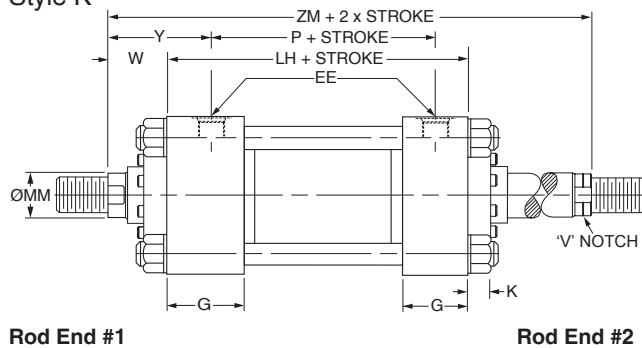

**Double Rod End Mounting Styles**

Mounting Styles for Single Rod Models	Mounting Styles for Corresponding Double Rod Models <sup>1</sup>		Dimensions Shown on This Page Supplement Dimensions on 1.50"-6.00" Bore Pages Listed Below
	Load Connected To Rod On Cylinder Mounting End	Load Connected To Rod Opposite Cylinder Mounting End	
T	KT	KT	10
TB	KTB	KTC	10
TD	KTD	KTD	10
J	KJ	KH	11
JB	KJB	KHB	12
JJ	KJJ	KHH	13
C	KC	KC	16
F	KF	KF	18
D	KD	KDB	20
DD	KDD <sup>2</sup>	KDD <sup>2</sup>	22
DE	KDE <sup>2</sup>	KDE <sup>2</sup>	23

<sup>1</sup> Connect load to piston rod without 'V' notch. If only one end of the Double Rod Cylinder is to be cushioned, be sure to clearly specify which end this will be.

<sup>2</sup> Specify XI dimension for Styles DD & DE from #1 rod end (without 'V' notch).

**How to Use Double Rod Cylinder Dimension Drawings**

To determine dimensions for a double rod cylinder, first refer to the desired single rod mounting style cylinder shown on preceding pages of this catalog. (See table above.) After selecting necessary dimensions from that drawing, return to this page supplement the single rod dimensions with those shown on drawing at right and dimension table below. Note that double rod cylinders have a head (Dim. G) at both ends and that dimension LH replaces LG. The double rod dimensions differ from, or are in addition to those for single rod cylinders shown on preceding pages and provide the information needed to completely dimension a double rod cylinder.

On a double rod cylinder where the two rod ends are different, be sure to clearly state which rod end is to be assembled at which end. Port position 1 is standard. If other than standard, specify pos. 2, 3 or 4 when viewed from rod end #1 only.

Bore Ø	Rod No.	MM Rod Ø	Add Stroke			Add 2X Stroke
			LH	SNK	SSK	ZM
1.50	1 (std.)	0.625	4.88	2.88	4.13	6.88
	2	1.000	4.88	2.88	4.13	7.63
2.00	1 (std.)	1.000	4.88	2.88	3.88	7.63
	2	1.375	4.88	2.88	3.88	8.13
2.50	1 (std.)	1.000	5.00	3.00	3.63	7.75
	2	1.750	5.00	3.00	3.63	8.75
	3	1.375	5.00	3.00	3.63	8.25
3.25	1 (std.)	1.375	5.75	3.50	4.38	9.00
	2	2.000	5.75	3.50	4.38	9.75
	3	1.750	5.75	3.50	4.38	9.50
4.00	1 (std.)	1.750	6.00	3.75	4.25	9.75
	2	2.500	6.00	3.75	4.25	10.50
	3	2.000	6.00	3.75	4.25	10.00
5.00	1 (std.)	2.000	6.50	4.25	4.75	10.50
	2	3.500	6.50	4.25	4.75	11.00
	3	2.500	6.50	4.25	4.75	11.00
	4	3.000	6.50	4.25	4.75	11.00
6.00	1 (std.)	2.500	7.38	4.88	5.13	11.88
	2	4.000	7.38	4.88	5.13	11.88
	3	3.000	7.38	4.88	5.13	11.88
	4	3.500	7.38	4.88	5.13	11.88
Replaces On single rod mounting styles:			LG	SN	SS	-
			All Mtg. Styles	F	C	All Mtg. Styles

**Series PH Bushing Retention<sup>3</sup>**

B = Bolt -On Bushing with Circular Retainer  
R = Tie Rod Retained Bushing

<sup>3</sup> Bushing retention style may vary when thrust key retainer or bushing drain option is included. Contact factory for details.

**Tie Rod Retained Bushing**

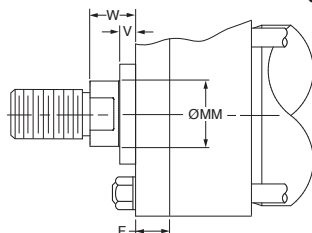

Bore Ø	Rod No.	MM Rod Ø	Mounting Style			
			TC, H, HB, HH, C, F, D, DB, DD, DE, BB, SB, SE	TB, TD	J, JB	JJ
1.50	1 (Std.)	0.625	B	R	R	B
	2	1.000	R	R	R	B
2.00	1 (Std.)	1.000	B	R	R	B
	2	1.375	R	R	R	B
2.50	1 (Std.)	1.000	B	B	B	B
	2	1.750	B	B	R	B
	3	1.375	B	B	B	B
3.25	All	All	B	B	B	B
4.00	All	All	B	B	B	B
5.00	1 (Std.)	2.000	B	B	B	B
	2	3.500	B	B	R	B
	3	2.500	B	B	B	B
	4	3.000	B	B	B	B
6.00	All	All	B	B	B	B

**PROP 65 WARNING** WARNING: This product can expose you to chemicals including **Lead and Lead Compounds** which are known to the State of California to cause cancer and birth defects or other reproductive harm. For more information go to [www.P65Warnings.ca.gov](http://www.P65Warnings.ca.gov)

PH Series  
1.50" - 8.00" Bore  
**B**

**Rod End Dimensions**

**Thread Style 4 (NFPA Style SM)  
 Small Male**

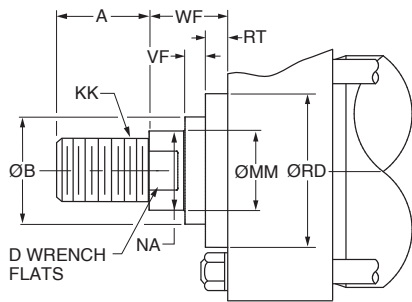

**Thread Style 8 (NFPA Style IM)  
 Intermediate Male**

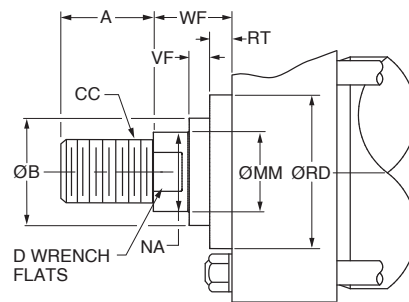

**Thread Style 9<sup>2</sup> (NFPA Style SF)  
 Small Female**

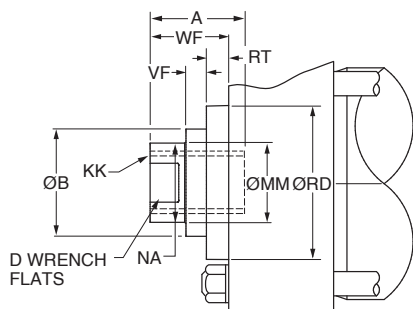

**Thread Style 55<sup>1</sup>**

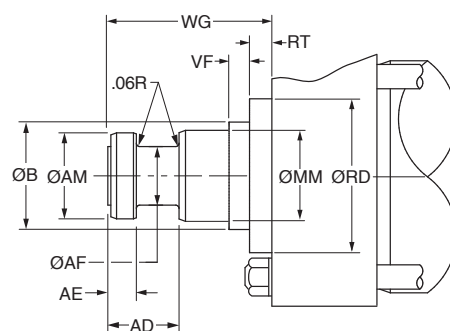

**Rod End Dimensions**

Bore Ø	Rod No.	MM Rod Ø	Thread		Rod Extensions and Pilot Dimensions							
			Style 8 CC	Style 4 & 9 KK	A	B Ø +.000 -.002	D	NA	VF	RD Ø	RT	WF
7.00	1 (std.)	3.000	2 3/4-12	2 1/4-12	3.50	3.749	2.63	2.88	0.40	5.26	0.85	2.25
	2	5.000	4 3/4-12	3 1/2-12	5.00	5.749	<sup>-3</sup>	4.88	0.34	7.25	0.91	2.25
	3	3.500	3 1/4-12	2 1/2-12	3.50	4.249	3.00	3.38	0.34	5.76	0.91	2.25
	4	4.000	3 3/4-12	3-12	4.00	4.749	3.38	3.88	0.34	6.31	0.91	2.25
	5	4.500	4 1/4-12	3 1/4-12	4.50	5.249	<sup>-3</sup>	4.38	0.34	6.94	0.91	2.25
8.00	1 (std.)	3.500	3 1/4-12	2 1/2-12	3.50	4.249	3.00	3.38	0.34	5.76	0.91	2.25
	2	5.500	5 1/4-12	4-12	5.50	6.249	<sup>-3</sup>	5.38	0.34	7.94	0.91	2.25
	3	4.000	3 3/4-12	3-12	4.00	4.749	3.38	3.88	0.34	6.31	0.91	2.25
	4	4.500	4 1/4-12	3 1/4-12	4.50	5.249	<sup>-3</sup>	4.38	0.34	6.94	0.91	2.25
	5	5.000	4 3/4-12	3 1/2-12	5.00	5.749	<sup>-3</sup>	4.88	0.34	7.25	0.91	2.25

**“Special” Thread Style 3**

Special thread, extension, rod eye, blank, etc., are also available.

To order, specify “Style 3” and give desired dimensions for KK, A, W or WF. If otherwise special, furnish dimensioned sketch.

<sup>1</sup> For special WG dimension, specify “Style 3” and give desired dimension for WG. For other changes, place “S” in the model code, and describe rod end with dimensioned sketch.

<sup>2</sup> Style 9 stroke restrictions may apply. See Style 9 Minimum Stroke Table on How to Order page for details.

<sup>3</sup> These piston rod numbers will have 4 spanner wrench holes instead of wrench flats. See rod drawings on 3H Large Bore Piston Rod Ends page for dimensions.

**Style 55 Rod End**

MM Rod Ø	AD	AE +.001 -.001	AF Ø	AM Ø	WG <sup>1</sup>
3.000	2.44	0.874	2.25	2.95	4.88
3.500	2.69	0.999	2.50	3.45	5.63
4.000	2.69	0.999	3.00	3.95	5.75
4.500	3.19	1.499	3.50	4.45	6.50
5.000	3.19	1.499	3.88	4.95	6.63
5.500	3.94	1.874	4.38	5.45	7.50

**B**  
 PH Series  
 1.50" - 8.00" Bore

**⚠ PROP 65 WARNING** WARNING: This product can expose you to chemicals including **Lead and Lead Compounds** which are known to the State of California to cause cancer and birth defects or other reproductive harm. For more information go to [www.P65Warnings.ca.gov](http://www.P65Warnings.ca.gov)

**Tie Rods Extended Both Ends**  
**Style TD**  
**(NFA Style MX1)**

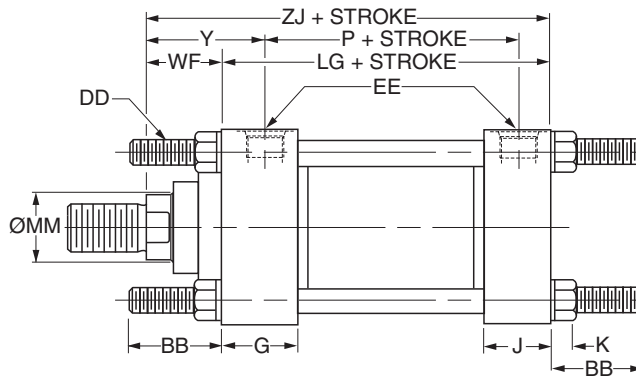
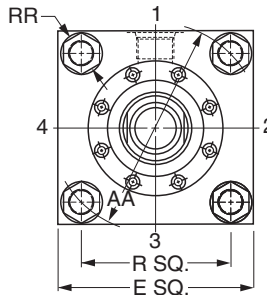
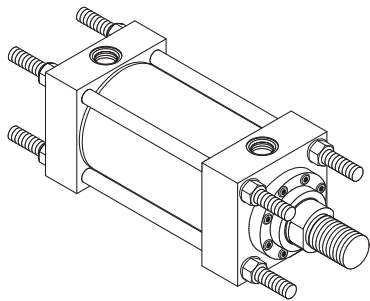

Basic Mounting (T) — NFA MXO — Not shown is no tie rod extended and can be supplied upon request.

**Style TD – Dimensional and Mounting Data**

Bore Ø	Rod No.	MM Rod Ø	AA	BB	DD	E	EE		G	J	K Max.	R	RR	WF	Y	Add Stroke		
							NPTF <sup>1</sup>	SAE <sup>2</sup>								LG	P	ZJ
7.00	1 (std.)	3.000	9.31	4.13	1 1/8-12	8.50	1 1/4	20	2.75	2.75	1.16	6.58	2.00	2.25	3.69	8.50	5.63	10.75
	2	5.000	9.31	4.13	1 1/8-12	8.50	1 1/4	20	2.75	2.75	1.16	6.58	2.00	2.25	3.69	8.50	5.63	10.75
	3	3.500	9.31	4.13	1 1/8-12	8.50	1 1/4	20	2.75	2.75	1.16	6.58	2.00	2.25	3.69	8.50	5.63	10.75
	4	4.000	9.31	4.13	1 1/8-12	8.50	1 1/4	20	2.75	2.75	1.16	6.58	2.00	2.25	3.69	8.50	5.63	10.75
	5	4.500	9.31	4.13	1 1/8-12	8.50	1 1/4	20	2.75	2.75	1.16	6.58	2.00	2.25	3.69	8.50	5.63	10.75
8.00	1 (std.)	3.500	10.61	4.50	1 1/4-12	9.50	1 1/2	24	3.00	3.00	1.28	7.50	2.19	2.25	3.81	9.50	6.38	11.75
	2	5.500	10.61	4.50	1 1/4-12	9.50	1 1/2	24	3.00	3.00	1.28	7.50	2.19	2.25	3.81	9.50	6.38	11.75
	3	4.000	10.61	4.50	1 1/4-12	9.50	1 1/2	24	3.00	3.00	1.28	7.50	2.19	2.25	3.81	9.50	6.38	11.75
	4	4.500	10.61	4.50	1 1/4-12	9.50	1 1/2	24	3.00	3.00	1.28	7.50	2.19	2.25	3.81	9.50	6.38	11.75
	5	5.000	10.61	4.50	1 1/4-12	9.50	1 1/2	24	3.00	3.00	1.28	7.50	2.19	2.25	3.81	9.50	6.38	11.75

<sup>1</sup>NPTF ports are available at no extra charge.

<sup>2</sup>SAE straight thread ports are standard and are indicated by port number.

**Style TB**

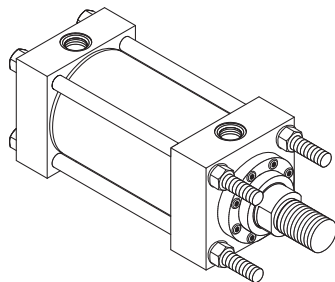

**Style TC**

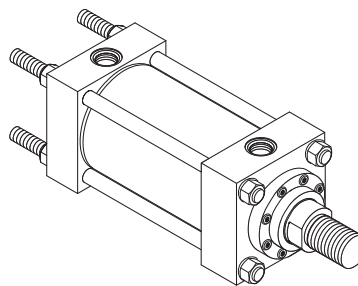

Dimensions for Style TB & TC may be obtained from the above dimensional table.

**⚠ PROP 65 WARNING** **WARNING:** This product can expose you to chemicals including **Lead and Lead Compounds** which are known to the State of California to cause cancer and birth defects or other reproductive harm. For more information go to [www.P65Warnings.ca.gov](http://www.P65Warnings.ca.gov)

PH Series  
 1.50" - 8.00" Bore

**Head Rectangular Flange Mounting**  
**Style J**  
(NFPA Style MF1)

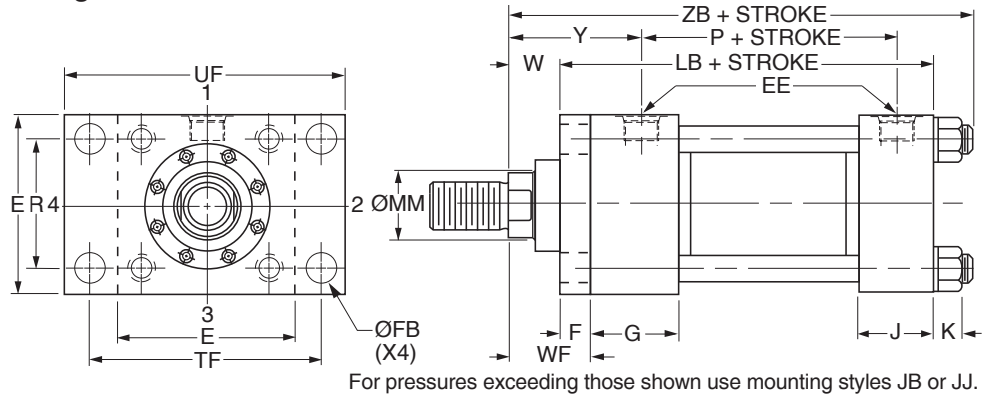
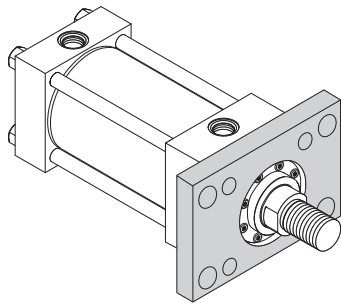

**Style J – Dimensional and Mounting Data**

Bore Ø	Rod No.	MM Rod Ø	E	EE		F	FB Ø	G	J	K Max.	R	TF	UF	W	WF	Y	Add Stroke		
				NPTF <sup>1</sup>	SAE <sup>2</sup>												LB	P	ZB Max.
7.00	1 (std.)	3.000	8.50	1 1/4	20	1.00	1.19	2.75	2.75	1.16	6.58	10.63	12.63	1.25	2.25	3.69	9.50	5.63	12.16
	2	5.000	8.50	1 1/4	20	1.00	1.19	2.75	2.75	1.16	6.58	10.63	12.63	1.25	2.25	3.69	9.50	5.63	12.16
	3	3.500	8.50	1 1/4	20	1.00	1.19	2.75	2.75	1.16	6.58	10.63	12.63	1.25	2.25	3.69	9.50	5.63	12.16
	4	4.000	8.50	1 1/4	20	1.00	1.19	2.75	2.75	1.16	6.58	10.63	12.63	1.25	2.25	3.69	9.50	5.63	12.16
	5	4.500	8.50	1 1/4	20	1.00	1.19	2.75	2.75	1.16	6.58	10.63	12.63	1.25	2.25	3.69	9.50	5.63	12.16
8.00	1 (std.)	3.500	9.50	1 1/2	24	1.00	1.31	3.00	3.00	1.28	7.50	11.81	14.00	1.25	2.25	3.81	10.50	6.38	13.28
	2	5.500	9.50	1 1/2	24	1.00	1.31	3.00	3.00	1.28	7.50	11.81	14.00	1.25	2.25	3.81	10.50	6.38	13.28
	3	4.000	9.50	1 1/2	24	1.00	1.31	3.00	3.00	1.28	7.50	11.81	14.00	1.25	2.25	3.81	10.50	6.38	13.28
	4	4.500	9.50	1 1/2	24	1.00	1.31	3.00	3.00	1.28	7.50	11.81	14.00	1.25	2.25	3.81	10.50	6.38	13.28
	5	5.000	9.50	1 1/2	24	1.00	1.31	3.00	3.00	1.28	7.50	11.81	14.00	1.25	2.25	3.81	10.50	6.38	13.28

<sup>1</sup>NPTF ports are available at no extra charge.

<sup>2</sup>SAE straight thread ports are standard and are indicated by port number.

**Style J –**  
**Maximum Operating Pressure**

Bore Ø	Max. psi Push <sup>3</sup>				
	Rod Code				
	1	2	3	4	5
7.00	1000	400	800	400	400
8.00	800	400	700	400	400

<sup>3</sup>Maximum pressure rating – push application.

**PH Series**  
**7.00" & 8.00" Bore**

**⚠ PROP 65 WARNING** **WARNING:** This product can expose you to chemicals including **Lead and Lead Compounds** which are known to the State of California to cause cancer and birth defects or other reproductive harm. For more information go to [www.P65Warnings.ca.gov](http://www.P65Warnings.ca.gov)

**Head Square Flange Mounting**  
**Style JB**  
(NFPA Style MF5)

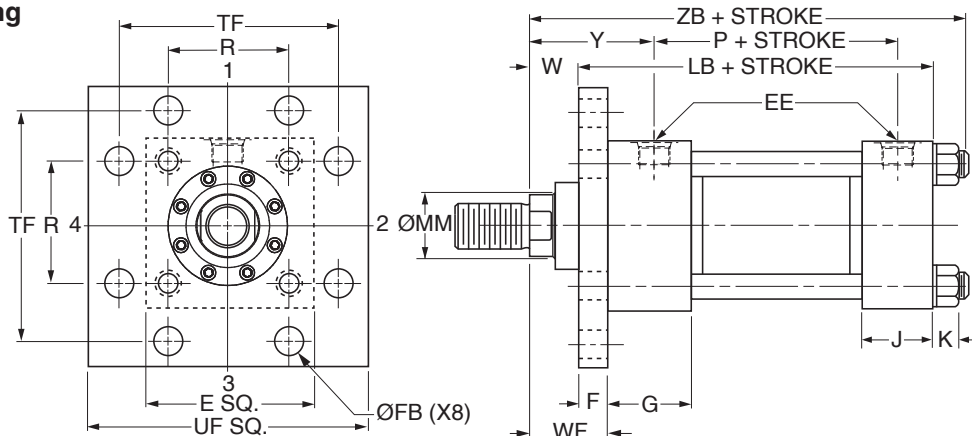
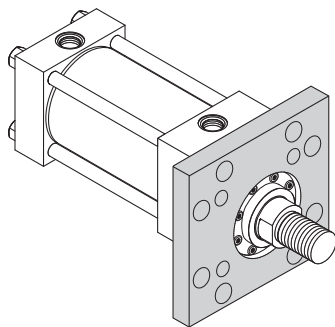

**Style JB – Dimensional and Mounting Data**

Bore Ø	Rod No.	MM Rod Ø	E	EE		F	FB Ø	G	J	K Max.	R	TF	UF	W	WF	Y	Add Stroke		
				NPTF <sup>1</sup>	SAE <sup>2</sup>												LB	P	ZB Max.
7.00	1 (std.)	3.000	8.50	1 1/4	20	1.00	1.19	2.75	2.75	1.16	6.58	10.63	12.63	1.25	2.25	3.69	9.50	5.63	12.16
	2	5.000	8.50	1 1/4	20	1.00	1.19	2.75	2.75	1.16	6.58	10.63	12.63	1.25	2.25	3.69	9.50	5.63	12.16
	3	3.500	8.50	1 1/4	20	1.00	1.19	2.75	2.75	1.16	6.58	10.63	12.63	1.25	2.25	3.69	9.50	5.63	12.16
	4	4.000	8.50	1 1/4	20	1.00	1.19	2.75	2.75	1.16	6.58	10.63	12.63	1.25	2.25	3.69	9.50	5.63	12.16
	5	4.500	8.50	1 1/4	20	1.00	1.19	2.75	2.75	1.16	6.58	10.63	12.63	1.25	2.25	3.69	9.50	5.63	12.16
8.00	1 (std.)	3.500	9.50	1 1/2	24	1.00	1.31	3.00	3.00	1.28	7.50	11.81	14.00	1.25	2.25	3.81	10.50	6.38	13.28
	2	5.500	9.50	1 1/2	24	1.00	1.31	3.00	3.00	1.28	7.50	11.81	14.00	1.25	2.25	3.81	10.50	6.38	13.28
	3	4.000	9.50	1 1/2	24	1.00	1.31	3.00	3.00	1.28	7.50	11.81	14.00	1.25	2.25	3.81	10.50	6.38	13.28
	4	4.500	9.50	1 1/2	24	1.00	1.31	3.00	3.00	1.28	7.50	11.81	14.00	1.25	2.25	3.81	10.50	6.38	13.28
	5	5.000	9.50	1 1/2	24	1.00	1.31	3.00	3.00	1.28	7.50	11.81	14.00	1.25	2.25	3.81	10.50	6.38	13.28

<sup>1</sup>NPTF ports are available at no extra charge.

<sup>2</sup>SAE straight thread ports are standard and are indicated by port number.

**Style JB – Maximum Operating Pressure**

Bore Ø	Max. psi Push <sup>3</sup>				
	Rod Code				
	1	2	3	4	5
7.00	2500	1500	2200	1500	1500
8.00	2000	1400	2000	1400	1400

<sup>3</sup>Maximum pressure rating – push application.

**⚠ PROP 65 WARNING** WARNING: This product can expose you to chemicals including **Lead and Lead Compounds** which are known to the State of California to cause cancer and birth defects or other reproductive harm. For more information go to [www.P65Warnings.ca.gov](http://www.P65Warnings.ca.gov)

PH Series  
7.00" & 8.00" Bore



**Head Rectangular Mounting**  
**Style JJ**  
 (NFPA Style ME5)

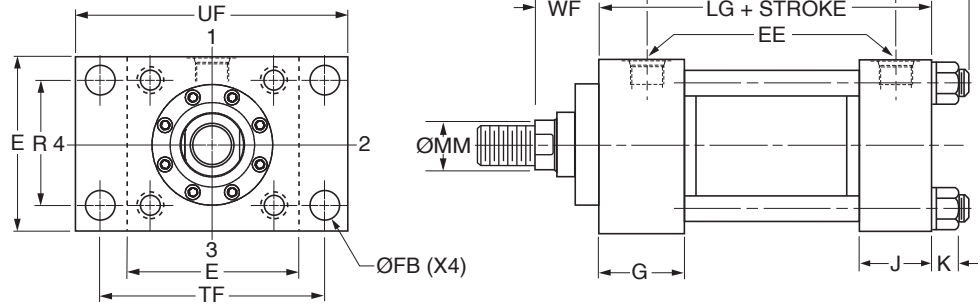
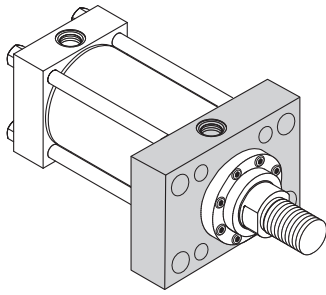

**Style JJ – Dimensional and Mounting Data**

Bore Ø	Rod No.	MM Rod Ø	E	EE		FB Ø	G	J	K Max.	R	TF	UF	WF	Y	Add Stroke		
				NPTF <sup>1</sup>	SAE <sup>2</sup>										LG	P	ZB Max.
7.00	1 (std.)	3.000	8.50	1 1/4	20	1.19	2.75	2.75	1.16	6.58	10.63	12.63	2.25	3.69	8.50	5.63	12.16
	2	5.000	8.50	1 1/4	20	1.19	2.75	2.75	1.16	6.58	10.63	12.63	2.25	3.69	8.50	5.63	12.16
	3	3.500	8.50	1 1/4	20	1.19	2.75	2.75	1.16	6.58	10.63	12.63	2.25	3.69	8.50	5.63	12.16
	4	4.000	8.50	1 1/4	20	1.19	2.75	2.75	1.16	6.58	10.63	12.63	2.25	3.69	8.50	5.63	12.16
	5	4.500	8.50	1 1/4	20	1.19	2.75	2.75	1.16	6.58	10.63	12.63	2.25	3.69	8.50	5.63	12.16
8.00	1 (std.)	3.500	9.50	1 1/2	24	1.31	3.00	3.00	1.28	7.50	11.81	14.00	2.25	3.81	9.50	6.38	13.28
	2	5.500	9.50	1 1/2	24	1.31	3.00	3.00	1.28	7.50	11.81	14.00	2.25	3.81	9.50	6.38	13.28
	3	4.000	9.50	1 1/2	24	1.31	3.00	3.00	1.28	7.50	11.81	14.00	2.25	3.81	9.50	6.38	13.28
	4	4.500	9.50	1 1/2	24	1.31	3.00	3.00	1.28	7.50	11.81	14.00	2.25	3.81	9.50	6.38	13.28
	5	5.000	9.50	1 1/2	24	1.31	3.00	3.00	1.28	7.50	11.81	14.00	2.25	3.81	9.50	6.38	13.28

<sup>1</sup>NPTF ports are available at no extra charge.

<sup>2</sup>SAE straight thread ports are standard and are indicated by port number.

**B**  
 PH Series  
 7.00" & 8.00" Bore

**⚠ PROP 65 WARNING** WARNING: This product can expose you to chemicals including **Lead and Lead Compounds** which are known to the State of California to cause cancer and birth defects or other reproductive harm. For more information go to [www.P65Warnings.ca.gov](http://www.P65Warnings.ca.gov)

**Cap Rectangular Flange Mounting**  
 Style H  
 (NFA Style MF2)

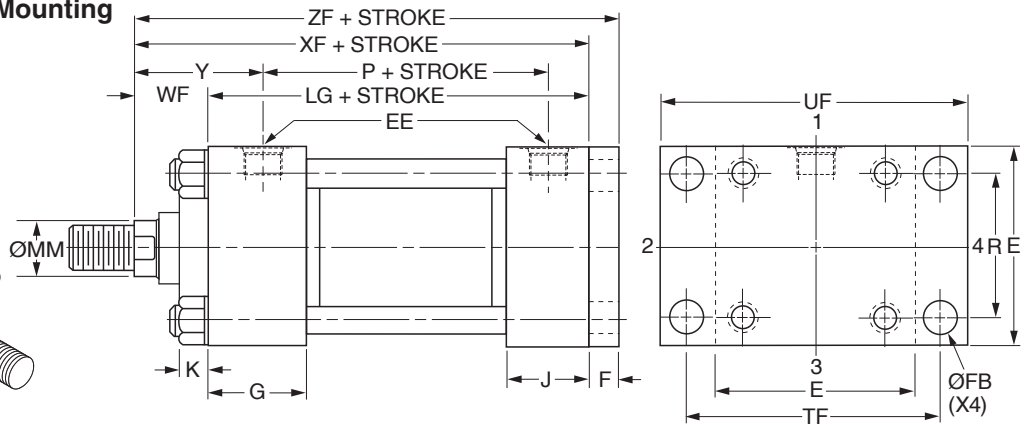
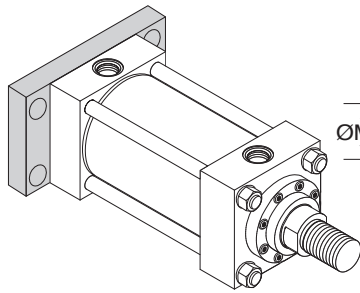

**Style H – Dimensional and Mounting Data**

Bore Ø	Rod No.	MM Rod Ø	E	EE		F	FB Ø	G	J	K Max.	R	TF	UF	WF	Y	Add Stroke			
				NPTF <sup>1</sup>	SAE <sup>2</sup>											LG	P	XF	ZF
7.00	1 (std.)	3.000	8.50	1 1/4	20	1.00	1.19	2.75	2.75	1.16	6.58	10.63	12.63	2.25	3.69	8.50	5.63	10.75	11.75
	2	5.000	8.50	1 1/4	20	1.00	1.19	2.75	2.75	1.16	6.58	10.63	12.63	2.25	3.69	8.50	5.63	10.75	11.75
	3	3.500	8.50	1 1/4	20	1.00	1.19	2.75	2.75	1.16	6.58	10.63	12.63	2.25	3.69	8.50	5.63	10.75	11.75
	4	4.000	8.50	1 1/4	20	1.00	1.19	2.75	2.75	1.16	6.58	10.63	12.63	2.25	3.69	8.50	5.63	10.75	11.75
	5	4.500	8.50	1 1/4	20	1.00	1.19	2.75	2.75	1.16	6.58	10.63	12.63	2.25	3.69	8.50	5.63	10.75	11.75
8.00	1 (std.)	3.500	9.50	1 1/2	24	1.00	1.31	3.00	3.00	1.28	7.50	11.81	14.00	2.25	3.81	9.50	6.38	11.75	12.75
	2	5.500	9.50	1 1/2	24	1.00	1.31	3.00	3.00	1.28	7.50	11.81	14.00	2.25	3.81	9.50	6.38	11.75	12.75
	3	4.000	9.50	1 1/2	24	1.00	1.31	3.00	3.00	1.28	7.50	11.81	14.00	2.25	3.81	9.50	6.38	11.75	12.75
	4	4.500	9.50	1 1/2	24	1.00	1.31	3.00	3.00	1.28	7.50	11.81	14.00	2.25	3.81	9.50	6.38	11.75	12.75
	5	5.000	9.50	1 1/2	24	1.00	1.31	3.00	3.00	1.28	7.50	11.81	14.00	2.25	3.81	9.50	6.38	11.75	12.75

<sup>1</sup>NPTF ports are available at no extra charge.

<sup>2</sup>SAE straight thread ports are standard and are indicated by port number.

**Style H – Maximum Operating Pressure**

Bore Ø	Max. psi Pull <sup>3</sup>				
	Rod Code				
	1	2	3	4	5
7.00	2000	3000	2000	2500	2800
8.00	1700	2500	1700	1800	2200

<sup>3</sup>Maximum pressure rating – pull application.

**⚠ PROP 65 WARNING** WARNING: This product can expose you to chemicals including **Lead and Lead Compounds** which are known to the State of California to cause cancer and birth defects or other reproductive harm. For more information go to [www.P65Warnings.ca.gov](http://www.P65Warnings.ca.gov)

PH Series  
7.00" & 8.00" Bore

**Cap Square Flange Mounting**  
**Style HB**  
(NFPA Style MF6)

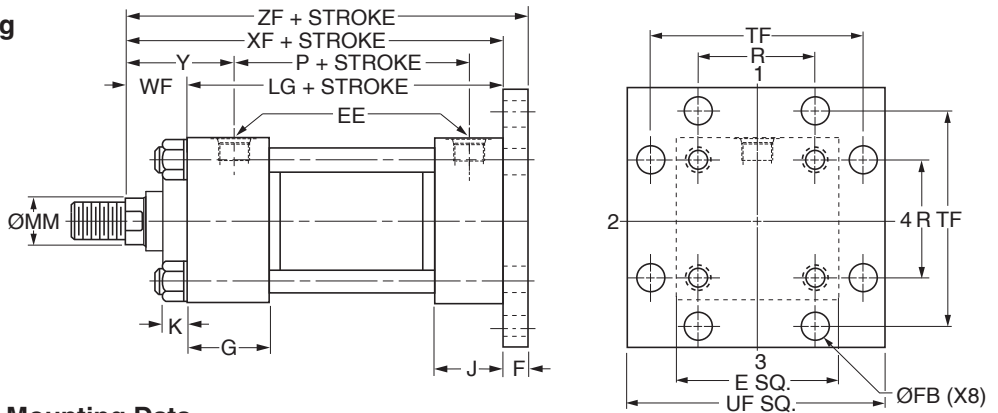
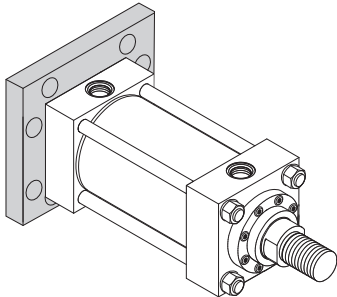

**Style HB – Dimensional and Mounting Data**

Bore Ø	Rod No.	MM Rod Ø	E	EE		F	FB Ø	G	J	K Max.	R	TF	UF	WF	Y	Add Stroke			
				NPTF <sup>1</sup>	SAE <sup>2</sup>											LG	P	XF	ZF
7.00	1 (std.)	3.000	8.50	1 1/4	20	1.00	1.19	2.75	2.75	1.16	6.58	10.63	12.63	2.25	3.69	8.50	5.63	10.75	11.75
	2	5.000	8.50	1 1/4	20	1.00	1.19	2.75	2.75	1.16	6.58	10.63	12.63	2.25	3.69	8.50	5.63	10.75	11.75
	3	3.500	8.50	1 1/4	20	1.00	1.19	2.75	2.75	1.16	6.58	10.63	12.63	2.25	3.69	8.50	5.63	10.75	11.75
	4	4.000	8.50	1 1/4	20	1.00	1.19	2.75	2.75	1.16	6.58	10.63	12.63	2.25	3.69	8.50	5.63	10.75	11.75
	5	4.500	8.50	1 1/4	20	1.00	1.19	2.75	2.75	1.16	6.58	10.63	12.63	2.25	3.69	8.50	5.63	10.75	11.75
8.00	1 (std.)	3.500	9.50	1 1/2	24	1.00	1.31	3.00	3.00	1.28	7.50	11.81	14.00	2.25	3.81	9.50	6.38	11.75	12.75
	2	5.500	9.50	1 1/2	24	1.00	1.31	3.00	3.00	1.28	7.50	11.81	14.00	2.25	3.81	9.50	6.38	11.75	12.75
	3	4.000	9.50	1 1/2	24	1.00	1.31	3.00	3.00	1.28	7.50	11.81	14.00	2.25	3.81	9.50	6.38	11.75	12.75
	4	4.500	9.50	1 1/2	24	1.00	1.31	3.00	3.00	1.28	7.50	11.81	14.00	2.25	3.81	9.50	6.38	11.75	12.75
	5	5.000	9.50	1 1/2	24	1.00	1.31	3.00	3.00	1.28	7.50	11.81	14.00	2.25	3.81	9.50	6.38	11.75	12.75

<sup>1</sup>NPTF ports are available at no extra charge. <sup>2</sup>SAE straight thread ports are standard and are indicated by port number.

**Cap Rectangular Mounting**  
**Style HH**  
(NFPA Style ME6)

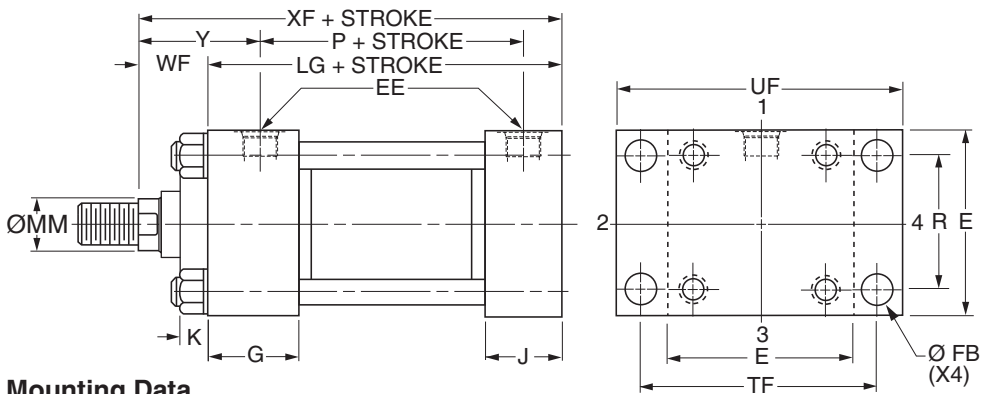
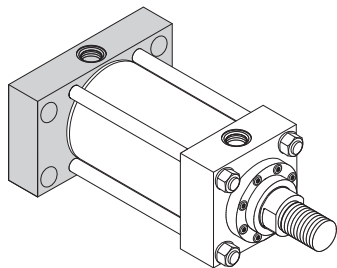

**Style HH – Dimensional and Mounting Data**

Bore Ø	Rod No.	MM Rod Ø	E	EE		FB Ø	G	J	K Max.	R	TF	UF	WF	Y	Add Stroke		
				NPTF <sup>1</sup>	SAE <sup>2</sup>										LG	P	XF
7.00	1 (std.)	3.000	8.50	1 1/4	20	1.19	2.75	2.75	1.16	6.58	10.63	12.63	2.25	3.69	8.50	5.63	10.75
	2	5.000	8.50	1 1/4	20	1.19	2.75	2.75	1.16	6.58	10.63	12.63	2.25	3.69	8.50	5.63	10.75
	3	3.500	8.50	1 1/4	20	1.19	2.75	2.75	1.16	6.58	10.63	12.63	2.25	3.69	8.50	5.63	10.75
	4	4.000	8.50	1 1/4	20	1.19	2.75	2.75	1.16	6.58	10.63	12.63	2.25	3.69	8.50	5.63	10.75
	5	4.500	8.50	1 1/4	20	1.19	2.75	2.75	1.16	6.58	10.63	12.63	2.25	3.69	8.50	5.63	10.75
8.00	1 (std.)	3.500	9.50	1 1/2	24	1.31	3.00	3.00	1.28	7.50	11.81	14.00	2.25	3.81	9.50	6.38	11.75
	2	5.500	9.50	1 1/2	24	1.31	3.00	3.00	1.28	7.50	11.81	14.00	2.25	3.81	9.50	6.38	11.75
	3	4.000	9.50	1 1/2	24	1.31	3.00	3.00	1.28	7.50	11.81	14.00	2.25	3.81	9.50	6.38	11.75
	4	4.500	9.50	1 1/2	24	1.31	3.00	3.00	1.28	7.50	11.81	14.00	2.25	3.81	9.50	6.38	11.75
	5	5.000	9.50	1 1/2	24	1.31	3.00	3.00	1.28	7.50	11.81	14.00	2.25	3.81	9.50	6.38	11.75

<sup>1</sup>NPTF ports are available at no extra charge. <sup>2</sup>SAE straight thread ports are standard and are indicated by port number.

**⚠ PROP 65 WARNING** WARNING: This product can expose you to chemicals including **Lead and Lead Compounds** which are known to the State of California to cause cancer and birth defects or other reproductive harm. For more information go to [www.P65Warnings.ca.gov](http://www.P65Warnings.ca.gov)

**Side Lug Mounting**  
**Style C**  
 (NFFA Style MS2)

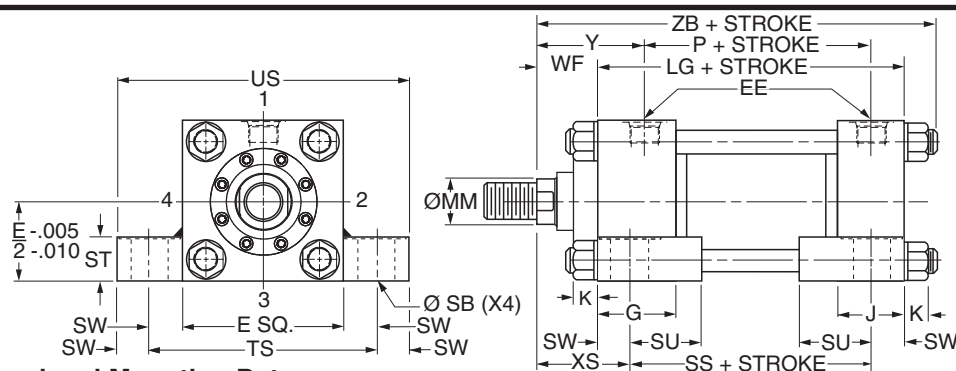
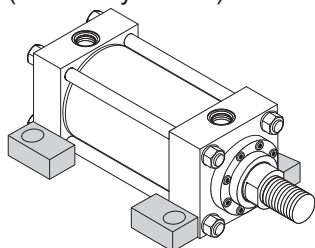

**Style C (Model 72) – Dimensional and Mounting Data**

Bore Ø	Rod No.	MM Rod Ø	E	EE		G	J	K Max.	SB Ø	ST	SU	SW	TS	US	WF	XS	Y	Add Stroke			
				NPTF <sup>1</sup>	SAE <sup>2</sup>													LG	P	SS	ZB Max.
7.00	1 (std.)	3.000	8.50	1 1/4	20	2.75	2.75	1.16	1.56	1.75	2.88	1.38	11.25	14.00	2.25	3.63	3.69	8.50	5.63	5.75	12.16
	2	5.000	8.50	1 1/4	20	2.75	2.75	1.16	1.56	1.75	2.88	1.38	11.25	14.00	2.25	3.63	3.69	8.50	5.63	5.75	12.16
	3	3.500	8.50	1 1/4	20	2.75	2.75	1.16	1.56	1.75	2.88	1.38	11.25	14.00	2.25	3.63	3.69	8.50	5.63	5.75	12.16
	4	4.000	8.50	1 1/4	20	2.75	2.75	1.16	1.56	1.75	2.88	1.38	11.25	14.00	2.25	3.63	3.69	8.50	5.63	5.75	12.16
	5	4.500	8.50	1 1/4	20	2.75	2.75	1.16	1.56	1.75	2.88	1.38	11.25	14.00	2.25	3.63	3.69	8.50	5.63	5.75	12.16
8.00	1 (std.)	3.500	9.50	1 1/2	24	3.00	3.00	1.28	1.56	1.75	2.88	1.38	12.25	15.00	2.25	3.63	3.81	9.50	6.38	6.75	13.28
	2	5.500	9.50	1 1/2	24	3.00	3.00	1.28	1.56	1.75	2.88	1.38	12.25	15.00	2.25	3.63	3.81	9.50	6.38	6.75	13.28
	3	4.000	9.50	1 1/2	24	3.00	3.00	1.28	1.56	1.75	2.88	1.38	12.25	15.00	2.25	3.63	3.81	9.50	6.38	6.75	13.28
	4	4.500	9.50	1 1/2	24	3.00	3.00	1.28	1.56	1.75	2.88	1.38	12.25	15.00	2.25	3.63	3.81	9.50	6.38	6.75	13.28
	5	5.000	9.50	1 1/2	24	3.00	3.00	1.28	1.56	1.75	2.88	1.38	12.25	15.00	2.25	3.63	3.81	9.50	6.38	6.75	13.28

<sup>1</sup>NPTF ports are available at no extra charge. <sup>2</sup>SAE straight thread ports are standard and are indicated by port number.

**Side Tapped Mounting**  
**Style F**  
 (NFFA Style MS4)

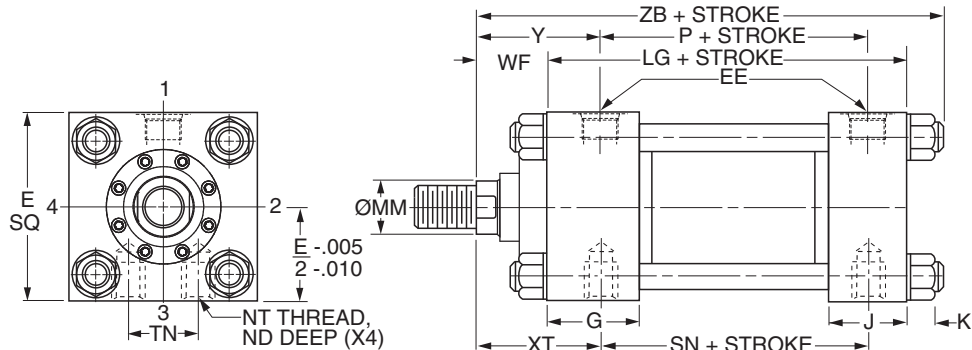
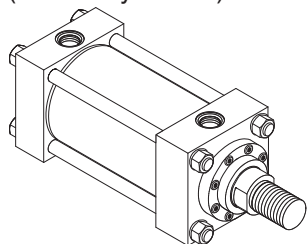

**Style F – Dimensional and Mounting Data**

Bore Ø	Rod No.	MM Rod Ø	E	EE		G	J	K Max.	ND	NT	TN	WF	XT	Y	Add Stroke			
				NPTF <sup>1</sup>	SAE <sup>2</sup>										LG	P	SN	ZB Max.
7.00	1 (std.)	3.000	8.50	1 1/4	20	2.75	2.75	1.16	1.13	1 1/2-6	3.75	2.25	3.81	3.69	8.50	5.63	5.88	12.16
	2	5.000	8.50	1 1/4	20	2.75	2.75	1.16	1.13	1 1/2-6	3.75	2.25	3.81	3.69	8.50	5.63	5.88	12.16
	3	3.500	8.50	1 1/4	20	2.75	2.75	1.16	1.13	1 1/2-6	3.75	2.25	3.81	3.69	8.50	5.63	5.88	12.16
	4	4.000	8.50	1 1/4	20	2.75	2.75	1.16	1.13	1 1/2-6	3.75	2.25	3.81	3.69	8.50	5.63	5.88	12.16
	5	4.500	8.50	1 1/4	20	2.75	2.75	1.16	1.13	1 1/2-6	3.75	2.25	3.81	3.69	8.50	5.63	5.88	12.16
8.00	1 (std.)	3.500	9.50	1 1/2	24	3.00	3.00	1.28	1.50	1 1/2-6	4.25	2.25	3.94	3.81	9.50	6.38	6.63	13.28
	2	5.500	9.50	1 1/2	24	3.00	3.00	1.28	1.50	1 1/2-6	4.25	2.25	3.94	3.81	9.50	6.38	6.63	13.28
	3	4.000	9.50	1 1/2	24	3.00	3.00	1.28	1.50	1 1/2-6	4.25	2.25	3.94	3.81	9.50	6.38	6.63	13.28
	4	4.500	9.50	1 1/2	24	3.00	3.00	1.28	1.50	1 1/2-6	4.25	2.25	3.94	3.81	9.50	6.38	6.63	13.28
	5	5.000	9.50	1 1/2	24	3.00	3.00	1.28	1.50	1 1/2-6	4.25	2.25	3.94	3.81	9.50	6.38	6.63	13.28

<sup>1</sup>NPTF ports are available at no extra charge. <sup>2</sup>SAE straight thread ports are standard and are indicated by port number.

**⚠ PROP 65 WARNING** WARNING: This product can expose you to chemicals including **Lead and Lead Compounds** which are known to the State of California to cause cancer and birth defects or other reproductive harm. For more information go to [www.P65Warnings.ca.gov](http://www.P65Warnings.ca.gov)

PH Series  
 7.00" & 8.00" Bore

**Cap Fixed Clevis Mounting**  
**Style BB**  
**(NFPA Style MP1)**

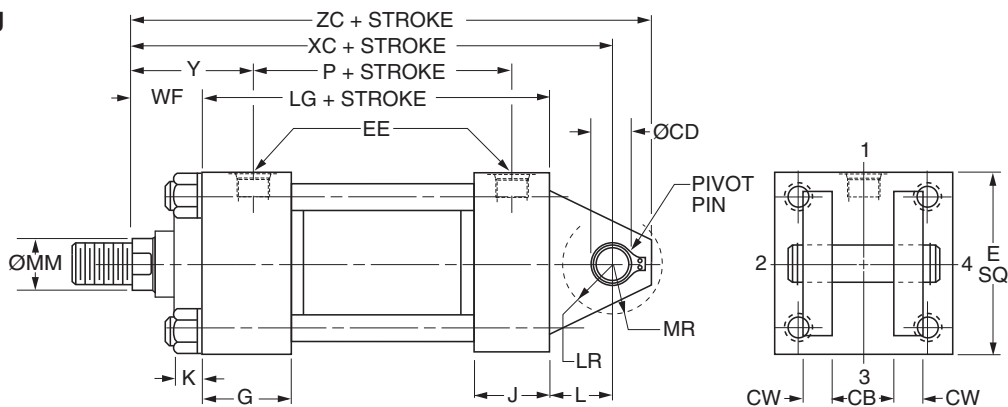
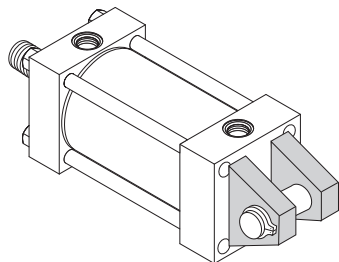

**Style BB – Dimensional and Mounting Data**

Bore Ø	Rod No.	MM Rod Ø	CB	CD <sup>3</sup> Ø +0.00 -0.02	CW	E	EE		G	J	K Max.	L	LR	MR
							NPTF <sup>1</sup>	SAE <sup>2</sup>						
7.00	1 (std.)	3.000	3.00	2.501	1.50	8.50	1 1/4	20	2.75	2.75	1.16	3.00	2.75	2.88
	2	5.000	3.00	2.501	1.50	8.50	1 1/4	20	2.75	2.75	1.16	3.00	2.75	2.88
	3	3.500	3.00	2.501	1.50	8.50	1 1/4	20	2.75	2.75	1.16	3.00	2.75	2.88
	4	4.000	3.00	2.501	1.50	8.50	1 1/4	20	2.75	2.75	1.16	3.00	2.75	2.88
	5	4.500	3.00	2.501	1.50	8.50	1 1/4	20	2.75	2.75	1.16	3.00	2.75	2.88
8.00	1 (std.)	3.500	3.00	3.001	1.50	9.50	1 1/2	24	3.00	3.00	1.28	3.25	3.25	3.13
	2	5.500	3.00	3.001	1.50	9.50	1 1/2	24	3.00	3.00	1.28	3.25	3.25	3.13
	3	4.000	3.00	3.001	1.50	9.50	1 1/2	24	3.00	3.00	1.28	3.25	3.25	3.13
	4	4.500	3.00	3.001	1.50	9.50	1 1/2	24	3.00	3.00	1.28	3.25	3.25	3.13
	5	5.000	3.00	3.001	1.50	9.50	1 1/2	24	3.00	3.00	1.28	3.25	3.25	3.13

<sup>1</sup>NPTF ports are available at no extra charge.

<sup>2</sup>SAE straight thread ports are standard and are indicated by port number.

<sup>3</sup>Diameter CD is pin diameter.

**Style BB – Dimensional and Mounting Data**

Bore Ø	Rod No.	MM Rod Ø	WF	Y	Add Stroke			
					LG	P	XC	ZC
7.00	1 (std.)	3.000	2.25	3.69	8.50	5.63	13.75	16.25
	2	5.000	2.25	3.69	8.50	5.63	13.75	16.25
	3	3.500	2.25	3.69	8.50	5.63	13.75	16.25
	4	4.000	2.25	3.69	8.50	5.63	13.75	16.25
	5	4.500	2.25	3.69	8.50	5.63	13.75	16.25
8.00	1 (std.)	3.500	2.25	3.81	9.50	6.38	15.00	17.75
	2	5.500	2.25	3.81	9.50	6.38	15.00	17.75
	3	4.000	2.25	3.81	9.50	6.38	15.00	17.75
	4	4.500	2.25	3.81	9.50	6.38	15.00	17.75
	5	5.000	2.25	3.81	9.50	6.38	15.00	17.75

**⚠ PROP 65 WARNING** WARNING: This product can expose you to chemicals including **Lead and Lead Compounds** which are known to the State of California to cause cancer and birth defects or other reproductive harm. For more information go to [www.P65Warnings.ca.gov](http://www.P65Warnings.ca.gov)

**Head Trunnion Mounting**  
**Style D**  
**(NFPA Style MT1)**

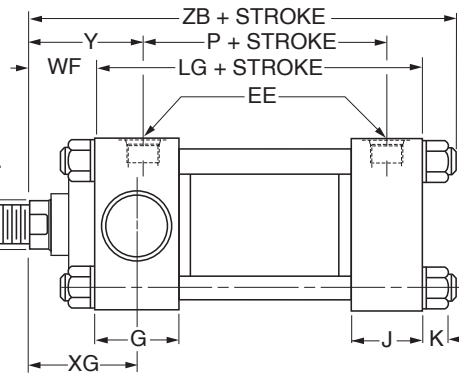
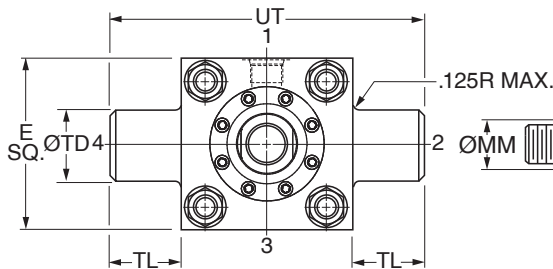
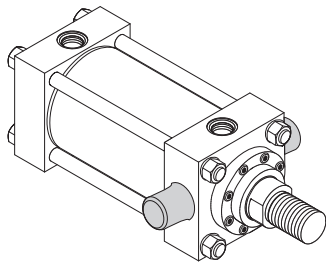

**Style D – Dimensional and Mounting Data**

Bore Ø	Rod No.	MM Rod Ø	E	EE		G	J	K Max.	TD Ø +.000 -0.002	TL	UT	WF	Y	XG
				NPTF <sup>1</sup>	SAE <sup>2</sup>									
7.00	1 (std.)	3.000	8.50	1 1/4	20	2.75	2.75	1.16	2.500	2.50	13.50	2.25	3.69	3.63
	2	5.000	8.50	1 1/4	20	2.75	2.75	1.16	2.500	2.50	13.50	2.25	3.69	3.63
	3	3.500	8.50	1 1/4	20	2.75	2.75	1.16	2.500	2.50	13.50	2.25	3.69	3.63
	4	4.000	8.50	1 1/4	20	2.75	2.75	1.16	2.500	2.50	13.50	2.25	3.69	3.63
	5	4.500	8.50	1 1/4	20	2.75	2.75	1.16	2.500	2.50	13.50	2.25	3.69	3.63
8.00	1 (std.)	3.500	9.50	1 1/2	24	3.00	3.00	1.28	3.000	3.00	15.50	2.25	3.81	3.75
	2	5.500	9.50	1 1/2	24	3.00	3.00	1.28	3.000	3.00	15.50	2.25	3.81	3.75
	3	4.000	9.50	1 1/2	24	3.00	3.00	1.28	3.000	3.00	15.50	2.25	3.81	3.75
	4	4.500	9.50	1 1/2	24	3.00	3.00	1.28	3.000	3.00	15.50	2.25	3.81	3.75
	5	5.000	9.50	1 1/2	24	3.00	3.00	1.28	3.000	3.00	15.50	2.25	3.81	3.75

<sup>1</sup>NPTF ports are available at no extra charge.

<sup>2</sup>SAE straight thread ports are standard and are indicated by port number.

**Style D – Dimensional and Mounting Data**

Bore Ø	Rod No.	MM Rod Ø	Add Stroke		
			LG	P	ZB Max.
7.00	1 (std.)	3.000	8.50	5.63	12.16
	2	5.000	8.50	5.63	12.16
	3	3.500	8.50	5.63	12.16
	4	4.000	8.50	5.63	12.16
	5	4.500	8.50	5.63	12.16
8.00	1 (std.)	3.500	9.50	6.38	13.28
	2	5.500	9.50	6.38	13.28
	3	4.000	9.50	6.38	13.28
	4	4.500	9.50	6.38	13.28
	5	5.000	9.50	6.38	13.28

**⚠ PROP 65 WARNING** WARNING: This product can expose you to chemicals including **Lead and Lead Compounds** which are known to the State of California to cause cancer and birth defects or other reproductive harm. For more information go to [www.P65Warnings.ca.gov](http://www.P65Warnings.ca.gov)

PH Series  
 7.00" & 8.00" Bore

**Cap Trunnion Mounting**  
 Style DB  
 (NFPA Style MT2)

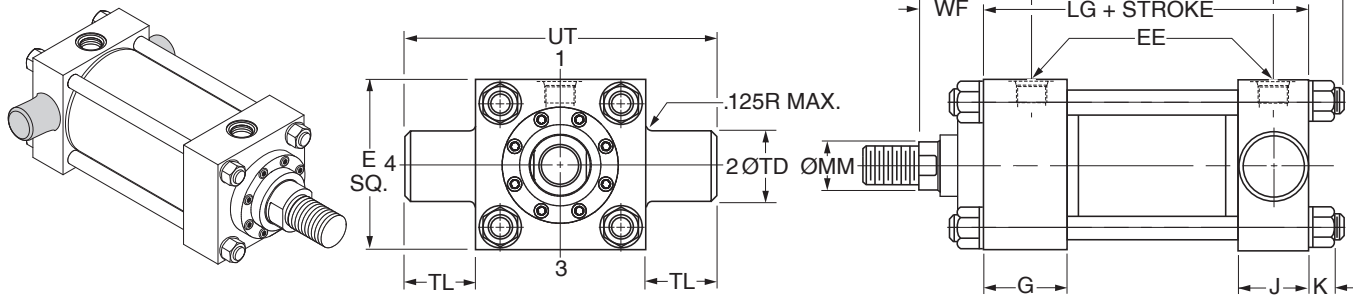

**Style DB – Dimensional and Mounting Data**

Bore Ø	Rod No.	MM Rod Ø	E	EE		G	J	K Max.	TD Ø +.000 - .002	TL	UT	WF	Y
				NPTF <sup>1</sup>	SAE <sup>2</sup>								
7.00	1 (std.)	3.000	8.50	1 1/4	20	2.75	2.75	1.16	2.500	2.50	13.50	2.25	3.69
	2	5.000	8.50	1 1/4	20	2.75	2.75	1.16	2.500	2.50	13.50	2.25	3.69
	3	3.500	8.50	1 1/4	20	2.75	2.75	1.16	2.500	2.50	13.50	2.25	3.69
	4	4.000	8.50	1 1/4	20	2.75	2.75	1.16	2.500	2.50	13.50	2.25	3.69
	5	4.500	8.50	1 1/4	20	2.75	2.75	1.16	2.500	2.50	13.50	2.25	3.69
8.00	1 (std.)	3.500	9.50	1 1/2	24	3.00	3.00	1.28	3.000	3.00	15.50	2.25	3.81
	2	5.500	9.50	1 1/2	24	3.00	3.00	1.28	3.000	3.00	15.50	2.25	3.81
	3	4.000	9.50	1 1/2	24	3.00	3.00	1.28	3.000	3.00	15.50	2.25	3.81
	4	4.500	9.50	1 1/2	24	3.00	3.00	1.28	3.000	3.00	15.50	2.25	3.81
	5	5.000	9.50	1 1/2	24	3.00	3.00	1.28	3.000	3.00	15.50	2.25	3.81

<sup>1</sup>NPTF ports are available at no extra charge.

<sup>2</sup>SAE straight thread ports are standard and are indicated by port number.

**Style DB – Dimensional and Mounting Data**

Bore Ø	Rod No.	MM Rod Ø	Add Stroke			
			LG	P	XJ	ZB Max
7.00	1 (std.)	3.000	8.50	5.63	9.38	12.16
	2	5.000	8.50	5.63	9.38	12.16
	3	3.500	8.50	5.63	9.38	12.16
	4	4.000	8.50	5.63	9.38	12.16
	5	4.500	8.50	5.63	9.38	12.16
8.00	1 (std.)	3.500	9.50	6.38	10.25	13.28
	2	5.500	9.50	6.38	10.25	13.28
	3	4.000	9.50	6.38	10.25	13.28
	4	4.500	9.50	6.38	10.25	13.28
	5	5.000	9.50	6.38	10.25	13.28

**B**  
 PH Series  
 7.00" & 8.00" Bore

**⚠ PROP 65 WARNING** WARNING: This product can expose you to chemicals including **Lead and Lead Compounds** which are known to the State of California to cause cancer and birth defects or other reproductive harm. For more information go to [www.P65Warnings.ca.gov](http://www.P65Warnings.ca.gov)

**Intermediate Fixed Trunnion Mounting**  
**Style DD**  
(NFPA Former Standard Style MT4)

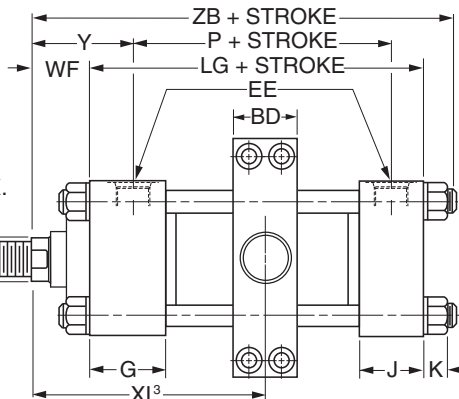
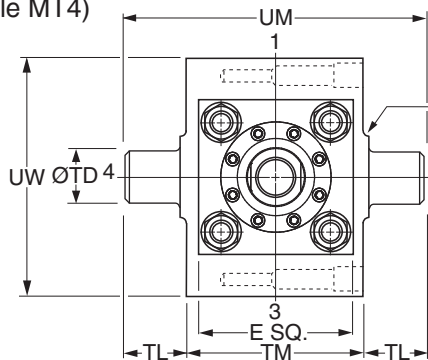
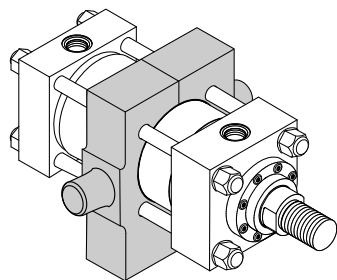

**Style DD – Dimensional and Mounting Data**

Bore Ø	Rod No.	MM Rod Ø	BD	E	EE		G	J	K Max.	TD Ø +.000 -0.002	TL	TM	UM	UW	WF	Y
					NPTF <sup>1</sup>	SAE <sup>2</sup>										
7.00	1 (std.)	3.000	3.00	8.50	1 1/4	20	2.75	2.75	1.16	2.500	2.50	9.75	14.75	11.50	2.25	3.69
	2	5.000	3.00	8.50	1 1/4	20	2.75	2.75	1.16	2.500	2.50	9.75	14.75	11.50	2.25	3.69
	3	3.500	3.00	8.50	1 1/4	20	2.75	2.75	1.16	2.500	2.50	9.75	14.75	11.50	2.25	3.69
	4	4.000	3.00	8.50	1 1/4	20	2.75	2.75	1.16	2.500	2.50	9.75	14.75	11.50	2.25	3.69
	5	4.500	3.00	8.50	1 1/4	20	2.75	2.75	1.16	2.500	2.50	9.75	14.75	11.50	2.25	3.69
8.00	1 (std.)	3.500	3.50	9.50	1 1/2	24	3.00	3.00	1.28	3.000	3.00	11.00	17.00	13.38	2.25	3.81
	2	5.500	3.50	9.50	1 1/2	24	3.00	3.00	1.28	3.000	3.00	11.00	17.00	13.38	2.25	3.81
	3	4.000	3.50	9.50	1 1/2	24	3.00	3.00	1.28	3.000	3.00	11.00	17.00	13.38	2.25	3.81
	4	4.500	3.50	9.50	1 1/2	24	3.00	3.00	1.28	3.000	3.00	11.00	17.00	13.38	2.25	3.81
	5	5.000	3.50	9.50	1 1/2	24	3.00	3.00	1.28	3.000	3.00	11.00	17.00	13.38	2.25	3.81

<sup>1</sup>NPTF ports are available at no extra charge.

<sup>2</sup>SAE straight thread ports are standard and are indicated by port number.

**Style DD – Dimensional and Mounting Data**

Bore Ø	Rod No.	MM Rod Ø	Minimum XI <sup>3</sup>		Style DD Minimum Stroke	Add Stroke				
			Styles 4, 8 & 9	Style 55		LG	P	Maximum XI <sup>4</sup>		ZB Max.
								Styles 4, 8 & 9	Style 55	
7.00	1 (std.)	3.000	6.56	9.19	0.13	8.50	5.63	6.44	9.06	12.16
	2	5.000	6.56	10.94	0.13	8.50	5.63	6.44	10.81	12.16
	3	3.500	6.56	9.94	0.13	8.50	5.63	6.44	9.81	12.16
	4	4.000	6.56	10.06	0.13	8.50	5.63	6.44	9.94	12.16
	5	4.500	6.56	10.81	0.13	8.50	5.63	6.44	10.69	12.16
8.00	1 (std.)	3.500	7.06	10.44	0.13	9.50	6.38	6.94	10.31	13.28
	2	5.500	7.06	12.31	0.13	9.50	6.38	6.94	12.19	13.28
	3	4.000	7.06	10.56	0.13	9.50	6.38	6.94	10.44	13.28
	4	4.500	7.06	11.31	0.13	9.50	6.38	6.94	11.19	13.28
	5	5.000	7.06	11.44	0.13	9.50	6.38	6.94	11.31	13.28

<sup>3</sup>Dimension XI to be specified by customer. Reference point for rod end Style 55 is end of piston rod.

<sup>4</sup>Dimensions shown are valid for standard WF and WG dimension.

**⚠ PROP 65 WARNING** WARNING: This product can expose you to chemicals including **Lead and Lead Compounds** which are known to the State of California to cause cancer and birth defects or other reproductive harm. For more information go to [www.P65Warnings.ca.gov](http://www.P65Warnings.ca.gov)



**Heavy Duty Intermediate Fixed Trunnion Mounting**  
**Style DE**  
(NFPA Current Standard Style MT4)

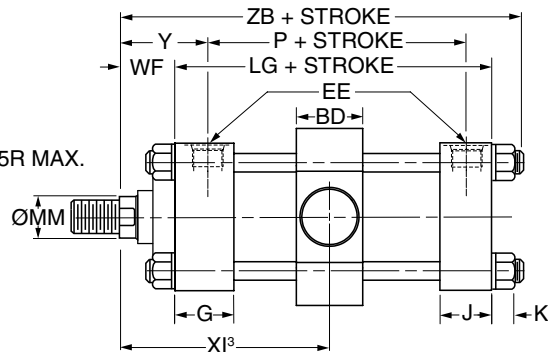
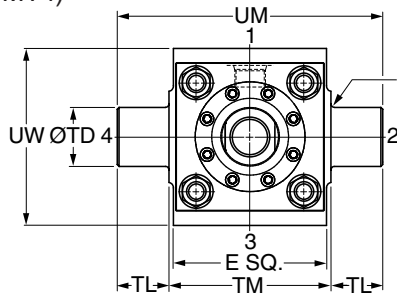
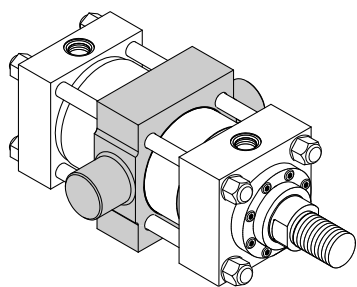

**Style DE – Dimensional and Mounting Data**

Bore Ø	Rod No.	MM Rod Ø	BD	E	EE		G	J	K Max.	TD Ø +.000 -0.002	TL	TM	UM	UW	WF	Y
					NPTF <sup>1</sup>	SAE <sup>2</sup>										
7.00	1 (std.)	3.000	4.000	8.50	1 1/4	20	2.75	2.75	1.16	3.500	2.50	9.75	14.75	11.38	2.25	3.69
	2	5.000	4.000	8.50	1 1/4	20	2.75	2.75	1.16	3.500	2.50	9.75	14.75	11.38	2.25	3.69
	3	3.500	4.000	8.50	1 1/4	20	2.75	2.75	1.16	3.500	2.50	9.75	14.75	11.38	2.25	3.69
	4	4.000	4.000	8.50	1 1/4	20	2.75	2.75	1.16	3.500	2.50	9.75	14.75	11.38	2.25	3.69
	5	4.500	4.000	8.50	1 1/4	20	2.75	2.75	1.16	3.500	2.50	9.75	14.75	11.38	2.25	3.69
8.00	1 (std.)	3.500	4.500	9.50	1 1/2	24	3.00	3.00	1.28	4.000	3.00	11.00	17.00	12.00	2.25	3.81
	2	5.500	4.500	9.50	1 1/2	24	3.00	3.00	1.28	4.000	3.00	11.00	17.00	12.00	2.25	3.81
	3	4.000	4.500	9.50	1 1/2	24	3.00	3.00	1.28	4.000	3.00	11.00	17.00	12.00	2.25	3.81
	4	4.500	4.500	9.50	1 1/2	24	3.00	3.00	1.28	4.000	3.00	11.00	17.00	12.00	2.25	3.81
	5	5.000	4.500	9.50	1 1/2	24	3.00	3.00	1.28	4.000	3.00	11.00	17.00	12.00	2.25	3.81

<sup>1</sup>NPTF ports are available at no extra charge.

<sup>2</sup>SAE straight thread ports are standard and are indicated by port number.

**Style DE – Dimensional and Mounting Data**

Bore Ø	Rod No.	MM Rod Ø	Minimum XI <sup>3</sup>		Style DE Minimum Stroke	Add Stroke				
			Styles 4, 8 & 9	Style 55		LG	P	Maximum XI <sup>4</sup>		ZB Max.
								Styles 4, 8 & 9	Style 55	
7.00	1 (std.)	3.000	7.06	9.69	1.13	8.50	5.63	5.94	8.56	12.16
	2	5.000	7.06	11.44	1.13	8.50	5.63	5.94	10.31	12.16
	3	3.500	7.06	10.44	1.13	8.50	5.63	5.94	9.31	12.16
	4	4.000	7.06	10.56	1.13	8.50	5.63	5.94	9.44	12.16
	5	4.500	7.06	11.31	1.13	8.50	5.63	5.94	10.19	12.16
8.00	1 (std.)	3.500	7.56	10.94	1.13	9.50	6.38	6.44	9.81	13.28
	2	5.500	7.56	12.81	1.13	9.50	6.38	6.44	11.69	13.28
	3	4.000	7.56	11.06	1.13	9.50	6.38	6.44	9.94	13.28
	4	4.500	7.56	11.81	1.13	9.50	6.38	6.44	10.69	13.28
	5	5.000	7.56	11.94	1.13	9.50	6.38	6.44	10.81	13.28

<sup>3</sup>Dimension XI to be specified by customer. Reference point for rod end Style 55 is end of piston rod.

<sup>4</sup>Dimensions shown are valid for standard WF and WG dimension.

**B**  
PH Series  
7.00" & 8.00" Bore

**⚠ PROP 65 WARNING** WARNING: This product can expose you to chemicals including **Lead and Lead Compounds** which are known to the State of California to cause cancer and birth defects or other reproductive harm. For more information go to [www.P65Warnings.ca.gov](http://www.P65Warnings.ca.gov)

**Spherical Bearing Mounting**  
**Style SE**

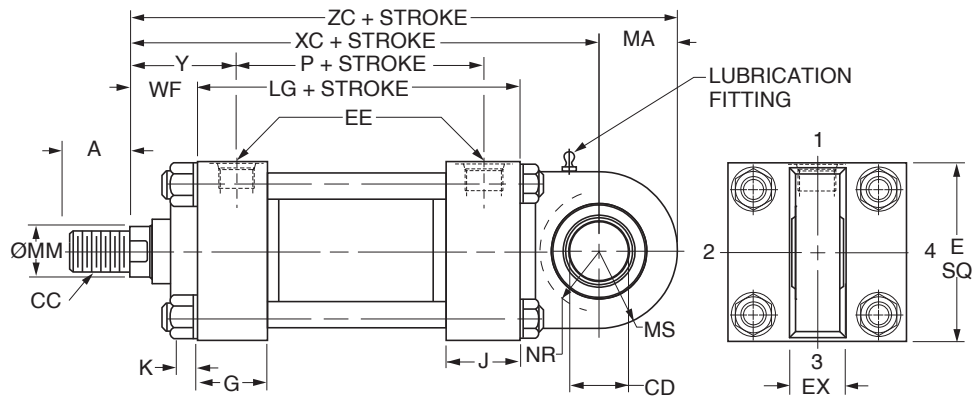
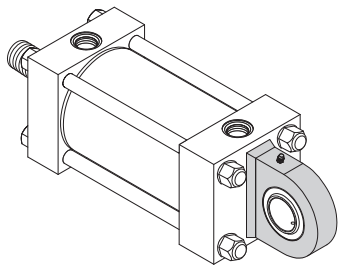

**Style SE — Dimensional and Mounting Data**

Bore Ø	Rod No.	MM Rod Ø	A	CD <sup>3</sup> Ø +0.0000 -0.0005	E	EE		EX	G	J	K Max.	MS	MA	NR	WF	Y
						NPTF <sup>1</sup>	SAE <sup>2</sup>									
7.00	1 (std.)	3.000	3.50	3.5000	8.50	1 1/4	20	3.06	2.75	2.75	1.16	4.00	4.00	3.68	2.25	3.69
	2	5.000	3.50	3.5000	8.50	1 1/4	20	3.06	2.75	2.75	1.16	4.00	4.00	3.68	2.25	3.69
	3	3.500	3.50	3.5000	8.50	1 1/4	20	3.06	2.75	2.75	1.16	4.00	4.00	3.68	2.25	3.69
	4	4.000	3.50	3.5000	8.50	1 1/4	20	3.06	2.75	2.75	1.16	4.00	4.00	3.68	2.25	3.69
	5	4.500	3.50	3.5000	8.50	1 1/4	20	3.06	2.75	2.75	1.16	4.00	4.00	3.68	2.25	3.69
8.00	1 (std.)	3.500	3.50	4.0000	9.50	1 1/2	24	3.50	3.00	3.00	1.28	4.50	4.50	4.13	2.25	3.81
	2	5.500	3.50	4.0000	9.50	1 1/2	24	3.50	3.00	3.00	1.28	4.50	4.50	4.13	2.25	3.81
	3	4.000	3.50	4.0000	9.50	1 1/2	24	3.50	3.00	3.00	1.28	4.50	4.50	4.13	2.25	3.81
	4	4.500	3.50	4.0000	9.50	1 1/2	24	3.50	3.00	3.00	1.28	4.50	4.50	4.13	2.25	3.81
	5	5.000	3.50	4.0000	9.50	1 1/2	24	3.50	3.00	3.00	1.28	4.50	4.50	4.13	2.25	3.81

<sup>1</sup>NPTF ports are available at no extra charge.

<sup>2</sup>SAE straight thread ports are standard and are indicated by port number.

<sup>3</sup>Dimension CD is pin diameter.

**Style SE – Dimensional and Mounting Data**

Bore Ø	Rod No.	MM Rod Ø	Thread Style 8 CC <sup>4</sup>	A	Add Stroke				
					LG	P	XC	XL	ZC
7.00	1 (std.)	3.000	2 3/4-12	3.50	8.50	5.63	15.25	23.25	19.25
	2	5.000	4	4	8.50	5.63	15.25	23.25	19.25
	3	3.500	4	4	8.50	5.63	15.25	23.25	19.25
	4	4.000	4	4	8.50	5.63	15.25	23.25	19.25
	5	4.500	4	4	8.50	5.63	15.25	23.25	19.25
8.00	1 (std.)	3.500	3 1/4-12	3.50	9.50	6.38	16.75	25.25	21.25
	2	5.500	4	4	9.50	6.38	16.75	25.25	21.25
	3	4.000	4	4	9.50	6.38	16.75	25.25	21.25
	4	4.500	4	4	9.50	6.38	16.75	25.25	21.25
	5	5.000	4	4	9.50	6.38	16.75	25.25	21.25

<sup>4</sup>To match pin diameter in rod eye and cap, when an oversize rod is required, specify rod end style '3', 'CC' thread and 'A' thread length for the standard rod diameter (Rod No. 1 for the bore), and 'WF' for the oversize rod.

**Style SE – Recommended maximum swivel angle on each side of the cylinder centerline.**

Bore Ø	Head End Mounted		Cap End Mounted	
	Angle a	Tan. of a	Angle a	Tan. of a
7.00	3.00°	0.052	3.00°	0.052
8.00	3.00°	0.052	3.00°	0.052

Note: Dimension X is the maximum off center mounting of the cylinder. To determine dimension X for various stroke lengths multiply the distance between pivot pin holes by tangent of angle a. For extended position use X = XL + 2X stroke.

**Mounting Information**

**Head End Mounting**

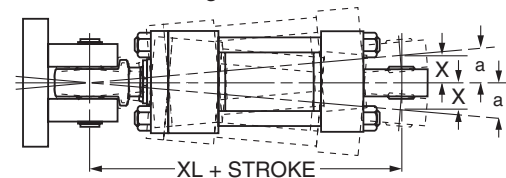

**Cap End Mounting**

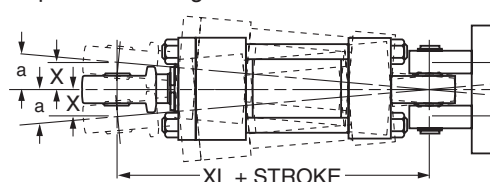

**⚠ PROP 65 WARNING** WARNING: This product can expose you to chemicals including **Lead and Lead Compounds** which are known to the State of California to cause cancer and birth defects or other reproductive harm. For more information go to [www.P65Warnings.ca.gov](http://www.P65Warnings.ca.gov)

PH Series  
 7.00" & 8.00" Bore

**Double Rod Cylinder**

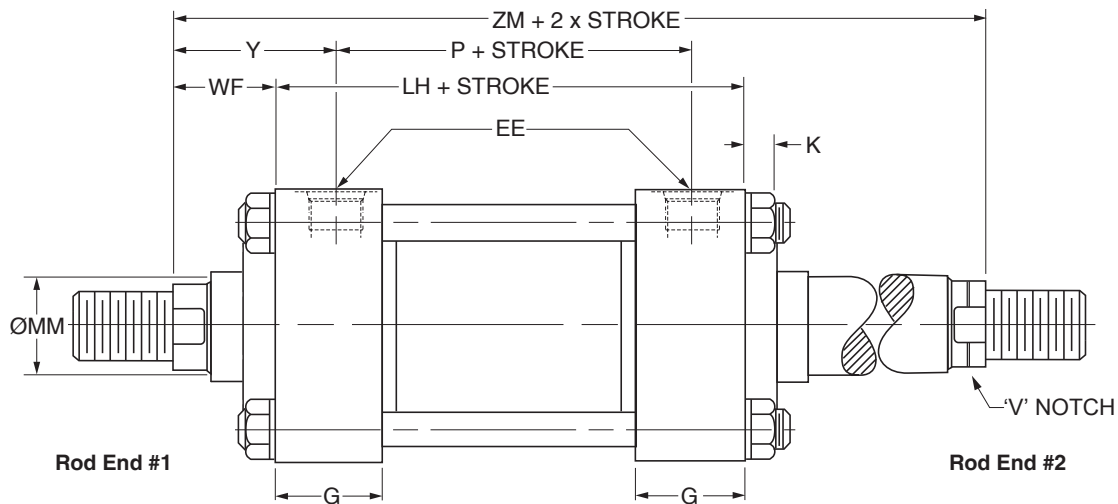

**Double Rod End Mounting Styles**

Mounting Styles for Single Rod Models	Mounting Styles for Corresponding Double Rod Models <sup>1</sup>		Dimensions Shown on This Page Supplement Dimensions on 7.00" - 8.00" Bore Pages Listed Below
	Load Connected To Rod On Cylinder Mounting End	Load Connected To Rod Opposite Cylinder Mounting End	
TB	KTB	KTC	28
TD	KTD	KTD	28
J	KJ	KH	29
JB	KJB	KHB	30
JJ	KJJ	KHH	31
C	KC	KC	34
F	KF	KF	34
D	KD	KDB	36
DD	KDD <sup>2</sup>	KDD <sup>2</sup>	38
DE	KDE <sup>2</sup>	KDE <sup>2</sup>	39

Bore Ø	Rod No.	MM Rod Ø	WF	Add Stroke			Add 2X Stroke
				LH	SNK	SSK	
7.00	1 (std.)	3.00	2.25	8.50	5.38	5.75	13.00
	2	5.00	2.25	8.50	5.38	5.75	13.00
	3	3.50	2.25	8.50	5.38	5.75	13.00
	4	4.00	2.25	8.50	5.38	5.75	13.00
	5	4.50	2.25	8.50	5.38	5.75	13.00
8.00	1 (std.)	3.50	2.25	9.50	6.13	6.75	14.00
	2	5.50	2.25	9.50	6.13	6.75	14.00
	3	4.00	2.25	9.50	6.13	6.75	14.00
	4	4.50	2.25	9.50	6.13	6.75	14.00
	5	5.00	2.25	9.50	6.13	6.75	14.00
<b>Replaces On single rod mounting styles:</b>				<b>LG</b>	<b>SN</b>	<b>SS</b>	<b>-</b>
				<b>All Mtg. Styles</b>	<b>F</b>	<b>C</b>	<b>All Mtg. Styles</b>

<sup>1</sup> Connect load to piston rod without 'V' notch. If only one end of the Double Rod Cylinder is to be cushioned, be sure to clearly specify which end this will be.

<sup>2</sup> Specify XI dimension for Styles DD & DE from #1 rod end (without 'V' notch).

**How to Use Double Rod Cylinder Dimension Drawings**

To determine dimensions for a double rod cylinder, first refer to the desired single rod mounting style cylinder shown on preceding pages of this catalog. (See table above.) After selecting necessary dimensions from that drawing, return to this page supplement the single rod dimensions with those shown on drawing at right and dimension table below. Note that double rod cylinders have a head (Dim. G) at both ends and that dimension LH replaces LG. The double rod dimensions differ from, or are in addition to those for single

rod cylinders shown on preceding pages and provide the information needed to completely dimension a double rod cylinder.

On a double rod cylinder where the two rod ends are different, be sure to clearly state which rod end is to be assembled at which end. Port position 1 is standard. If other than standard, specify pos. 2, 3 or 4 when viewed from rod end #1 only.

**⚠ PROP 65 WARNING** WARNING: This product can expose you to chemicals including **Lead and Lead Compounds** which are known to the State of California to cause cancer and birth defects or other reproductive harm. For more information go to [www.P65Warnings.ca.gov](http://www.P65Warnings.ca.gov)

**Notes**

PH Series  
10.00" - 20.00"  

 **PROP 65 WARNING** **WARNING:** This product can expose you to chemicals including **Lead and Lead Compounds** which are known to the State of California to cause cancer and birth defects or other reproductive harm. For more information go to [www.P65Warnings.ca.gov](http://www.P65Warnings.ca.gov)

**Section C****Series PH 10.00" - 20.00" Bore  
Heavy Duty Hydraulic Cylinders**

Performance	48
Construction	49
Model Code / How to Order	50-51
Piston Seal Options	52
Hybrid Composite Bushing	53
Specifications, Mounting Styles	54
Rod End Styles and Dimensions	55
TD, TB, TC Mount Dimensions	56
C Mount Dimensions	57
JJ Mount Dimensions	58
JB Mount Dimensions	59
HH Mount Dimensions	60
HB Mount Dimensions	61
BB Mount Dimensions	62
D Mount Dimensions	63
DB Mount Dimensions	64
DD Mount Dimensions	65
Double Rod Cylinders / Gland Retention	66

**⚠ PROP 65 WARNING** WARNING: This product can expose you to chemicals including **Lead and Lead Compounds** which are known to the State of California to cause cancer and birth defects or other reproductive harm. For more information go to [www.P65Warnings.ca.gov](http://www.P65Warnings.ca.gov)

## The large bore, high pressure hydraulic cylinder Schrader Bellows designed to meet your needs

Schrader Bellows PH Series large bore cylinders provide unmatched reliability, performance, and innovative design features that aid in increasing productivity while reducing operating costs.

Schrader Bellows' externally removable bolted bushing assembly makes preventive and routine maintenance quick and easy! In many cases, the cylinder does not have to be removed or disassembled to facilitate service. Our innovative design provides for fast turn around, reduced downtime, and increased productivity.

In addition to our removable bushing assembly, PH Series cylinders also include a multitude of innovative design features such as: anti-extrusion body end seals, floating cushions, hi load piston (standard), and various port and rod end options to meet your application requirements.

Every PH Series cylinder is individually tested before leaving our plant to assure proper and leak free operation. All PH Series cylinders come with an eighteen month warranty standard.

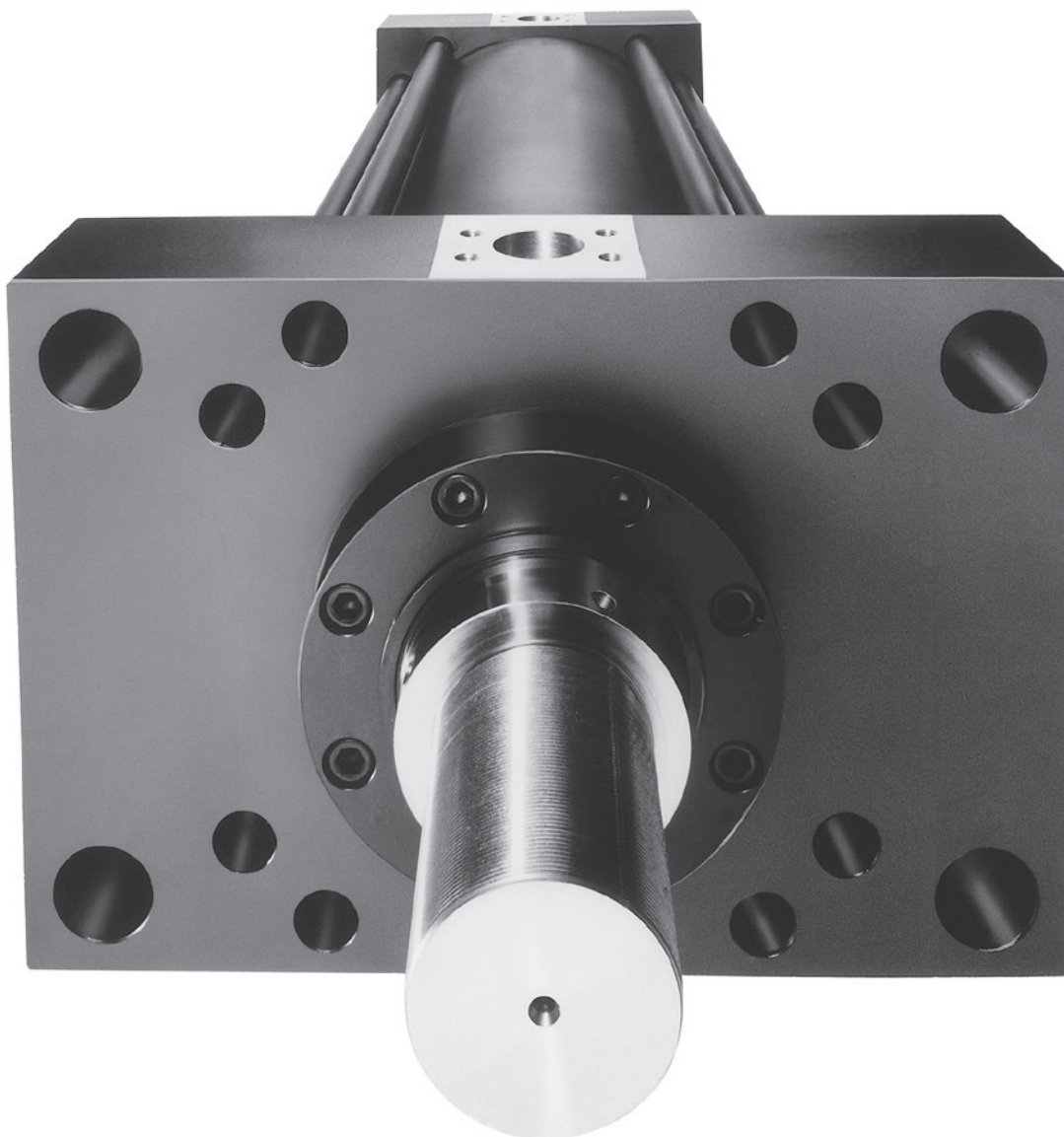

PH Series  
10.00" - 20.00"  
C

**⚠ PROP 65 WARNING** WARNING: This product can expose you to chemicals including **Lead and Lead Compounds** which are known to the State of California to cause cancer and birth defects or other reproductive harm. For more information go to [www.P65Warnings.ca.gov](http://www.P65Warnings.ca.gov)

# These innovative design features make Schrader Bellows PH Series your best choice... for all your large bore heavy duty hydraulic cylinder applications.

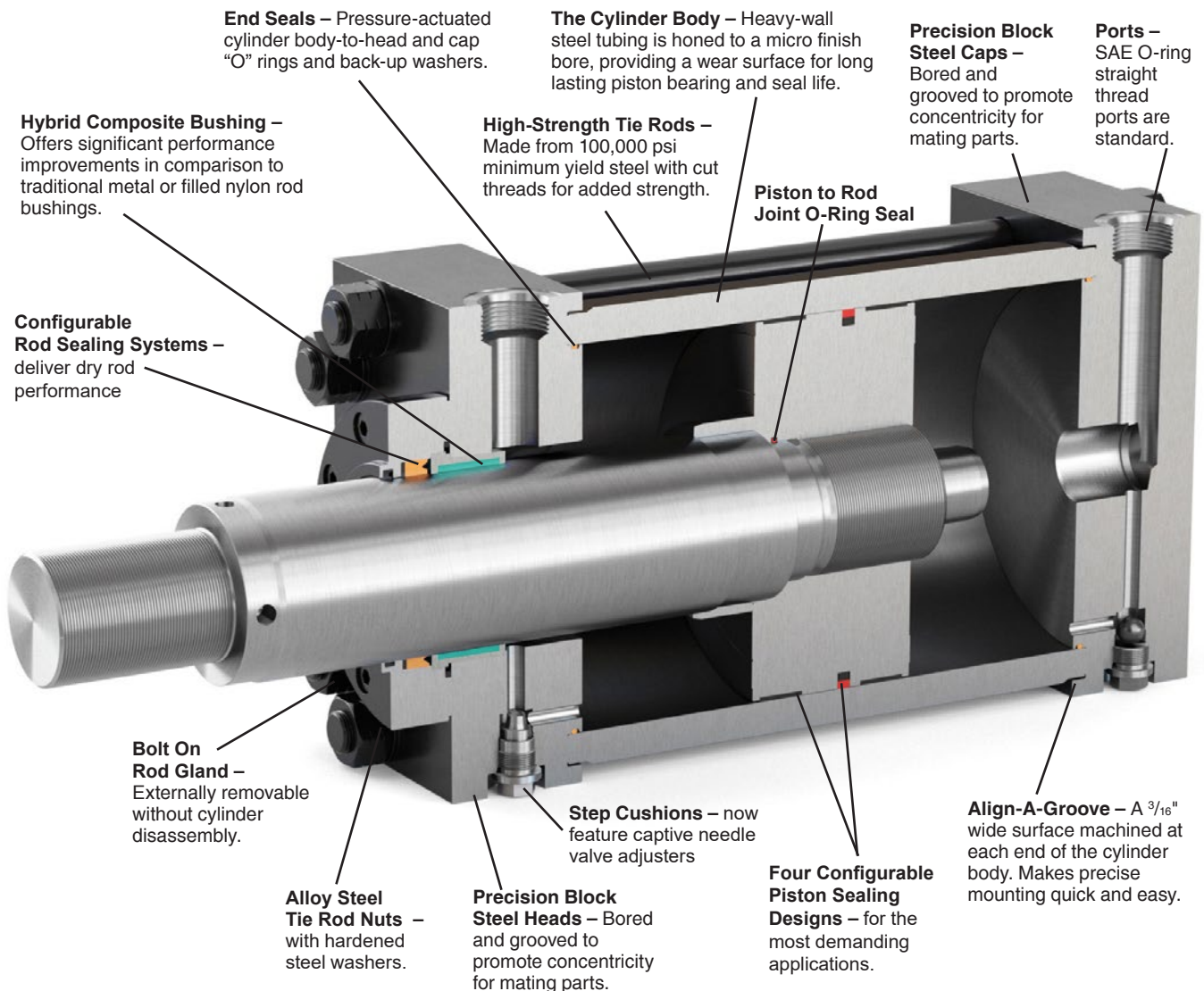

C  
PH Series  
10.00" - 20.00"

**⚠ PROP 65 WARNING** WARNING: This product can expose you to chemicals including **Lead and Lead Compounds** which are known to the State of California to cause cancer and birth defects or other reproductive harm. For more information go to [www.P65Warnings.ca.gov](http://www.P65Warnings.ca.gov)

**PH Large Bore Model Code**

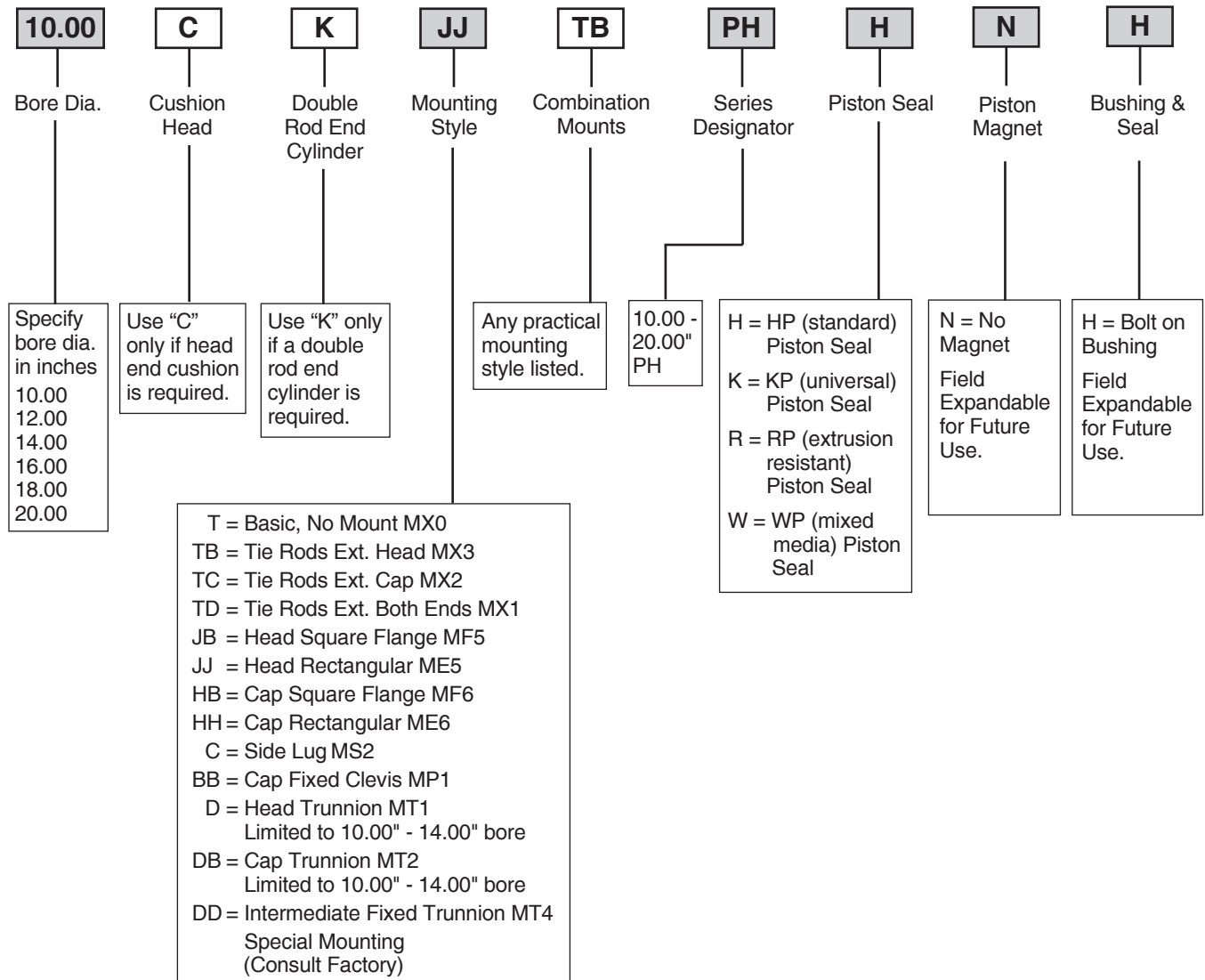

PH Series 10.00" - 20.00"

Shaded boxes identify required model number fields.

**⚠ PROP 65 WARNING** **WARNING:** This product can expose you to chemicals including **Lead and Lead Compounds** which are known to the State of California to cause cancer and birth defects or other reproductive harm. For more information go to [www.P65Warnings.ca.gov](http://www.P65Warnings.ca.gov)



**PH Large Bore Model Code**

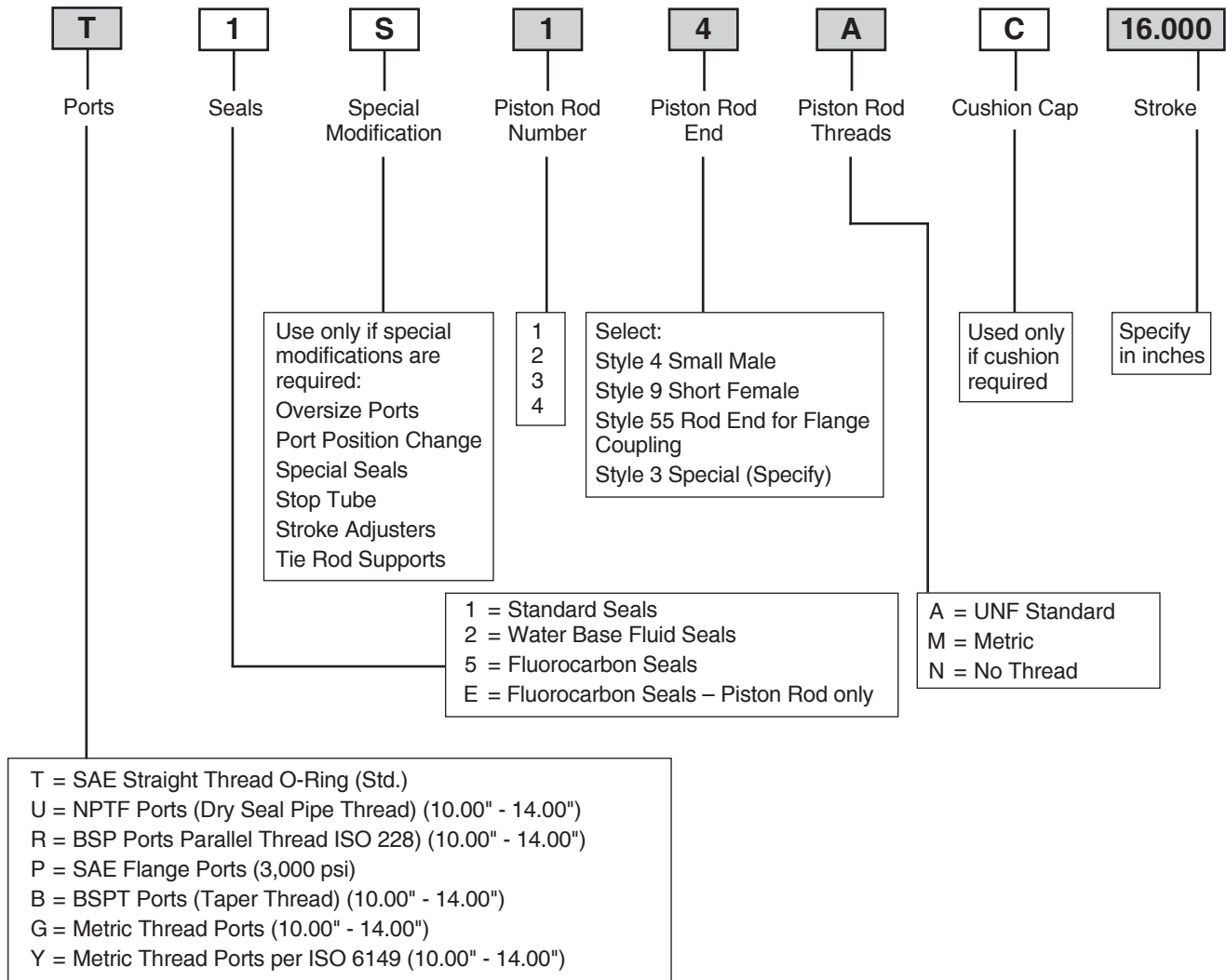

**Style 9 Minimum Stroke Table**

Bore Ø	Rod Ø	Minimum Stroke
10.00	4.500	1.125
	5.000	1.375
	5.500	2.000
	7.000	3.125
12.00	5.500	1.250
	7.000	2.375
	8.000	3.125
14.00	7.000	2.000
	8.000	2.750
	10.000	4.250
16.00	8.000	1.750
	9.000	2.500
	10.000	3.250
18.00	9.000	1.500
	10.000	2.250
20.00	10.000	1.250

Shaded boxes identify required model number fields.

**⚠ PROP 65 WARNING** **WARNING:** This product can expose you to chemicals including **Lead and Lead Compounds** which are known to the State of California to cause cancer and birth defects or other reproductive harm. For more information go to [www.P65Warnings.ca.gov](http://www.P65Warnings.ca.gov)

**Piston Seal Selection**

Schrader Bellows Piston Seal options HP, KP, RP and WP are available in a number of different Seal Classes. Because the Schrader Bellows Model Number includes Seal Class but does not include a code for piston seal style, a default piston seal style is designated for each seal class. In the table below rows list each seal class and the columns list each piston style.

Available piston styles for each seal class are identified with an 'X' and the default piston seal style is in the shaded cell. To specify an available piston seal style that is not standard, place an 'S' in Special Modification field of the model number and specify the required piston seal style with text.

Seal Class	Piston Seal Options (Shaded cell is default standard)			
	HP	KP	RP	WP
<b>TG - Class 1 - Polyurethane &amp; Nitrile</b>	X	X	X	X
<b>BG - Class 2 - Nitrile</b>	N/A	X	X	X
<b>VG - Class 5 - Fluorocarbon<sup>1</sup></b>	N/A	X	X	X
<b>EG - Class 5 Rod Bushing Seals Only</b>	N/A	X	X	X

**One Common Piston for 4 Seal Styles**

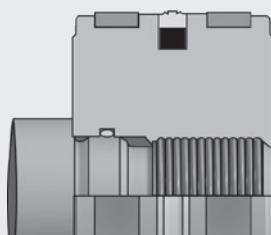

**Standard HP** style with polyurethane piston seal – excellent for most cycling and load holding applications.

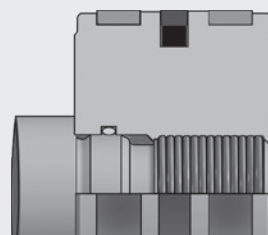

**Optional RP** style with thermoplastic piston seal – superior extrusion resistance to extreme pressure spikes with drift-free performance.

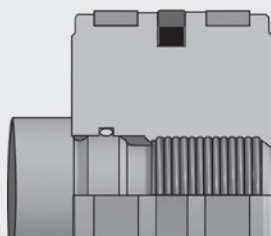

**Optional KP** style with filled PTFE piston seal – low friction, high heat resistance for cycling and load holding service.

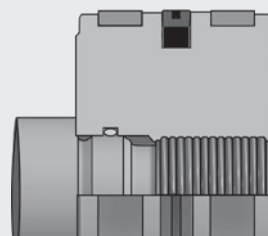

**Optional WP** style mixed media piston seal – low friction primary seal with redundant elastomer delivers superior performance with dissimilar media on either side of the piston.

**⚠ PROP 65 WARNING** WARNING: This product can expose you to chemicals including **Lead and Lead Compounds** which are known to the State of California to cause cancer and birth defects or other reproductive harm. For more information go to [www.P65Warnings.ca.gov](http://www.P65Warnings.ca.gov)

# PH Series Large Bore Hybrid Composite Bushing

Innovative Solutions from  
 Schrader Bellows

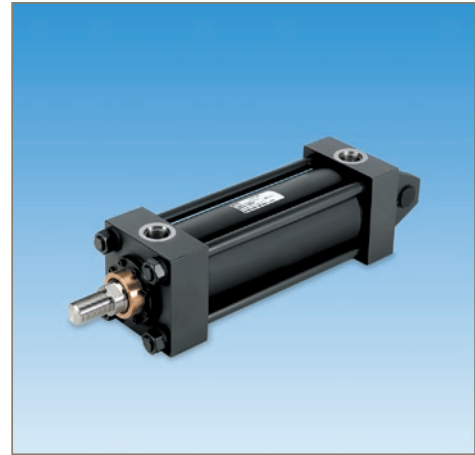

## Customer Value Proposition:



The Schrader Bellows PH Series Large Bore Hybrid Composite Bushing installed inboard of the primary rod sealing package offers significant performance improvements in comparison to Metal or Filled Nylon Rod Bushings

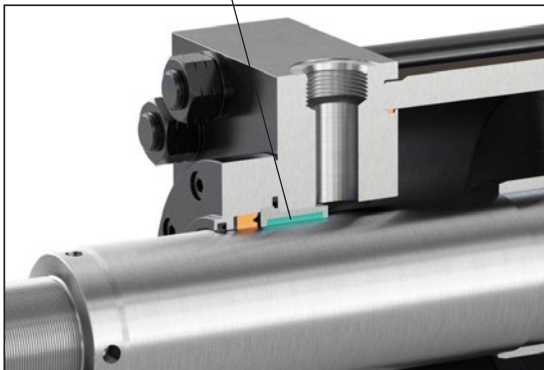

## Contact Information:

Schrader Bellows  
**Cylinder Division**  
 500 S. Wolf Rd.  
 Des Plaines, IL 60016  
[www.schrader-bellows.com](http://www.schrader-bellows.com)

phone 847 298 2400  
 fax 800 892 1008

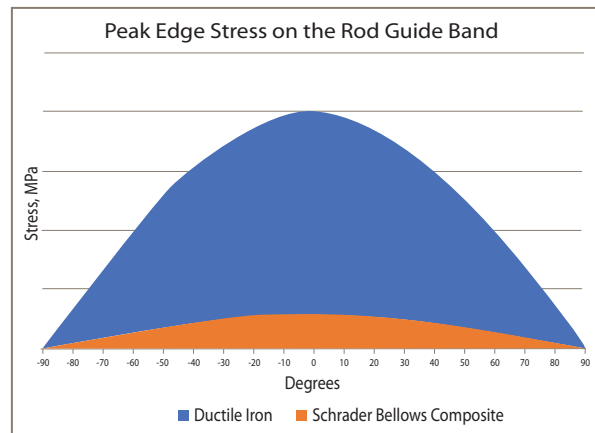

### Key Takeaway:

Contact stress is reduced when any side load force is distributed over a greater area.  
 See how Schrader Bellows' composite bearing performs over Ductile Iron.

## Product Features:

### Schrader Bellows' Hybrid Composite Versus Metal Bushings

- Better ability to conform to bending deflections resulting in lower peak stresses
- Self lubricating with lower friction
- Ideal for High Water Content fluids

### Schrader Bellows' Hybrid Composite Versus Filled Nylon Bushings

- Higher strength
- Very low water absorption
- Wider temperature range

**C**  
 PH Series  
 10.00" - 20.00"

**⚠ PROP 65 WARNING** WARNING: This product can expose you to chemicals including **Lead and Lead Compounds** which are known to the State of California to cause cancer and birth defects or other reproductive harm. For more information go to [www.P65Warnings.ca.gov](http://www.P65Warnings.ca.gov)

**Standard Specifications**

- Heavy Duty Service
- Standard Construction – Square Head – Tie Rod Design
- Nominal Pressure – 3000 psi<sup>1</sup>
- Standard Fluid – Hydraulic Oil
- Standard Temperature – -10°F to +165°F
- Bore Sizes – 10.00" through 20.00"
- Piston Rod Diameter – 4.500" through 10.000"
- Mounting Styles – 12 standard styles at various application ratings
- Strokes – Available in any practical stroke length
- Cushions – Optional at either end or both ends of stroke
- Rod Ends – Three Standard Choices – Specials to Order

<sup>1</sup> If hydraulic operating pressure exceeds 3000 psi, send application data for engineering evaluation and recommendation.

*In line with our policy of continuing product improvement, specifications in this catalog are subject to change.*

**Available Mounting Styles**

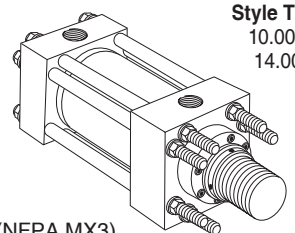
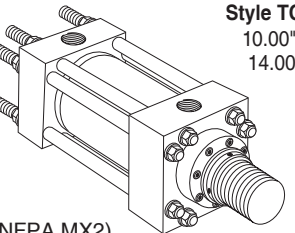
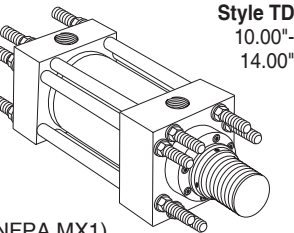
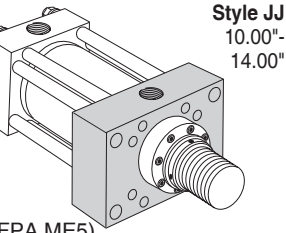
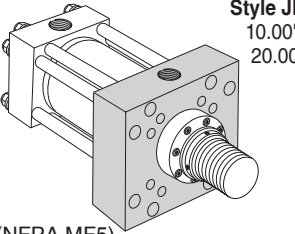
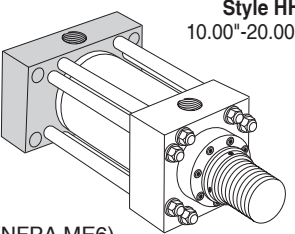
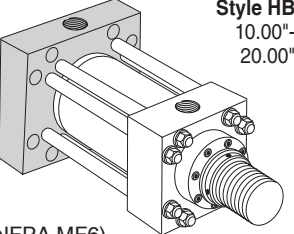
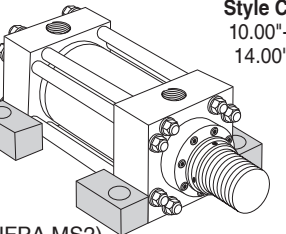
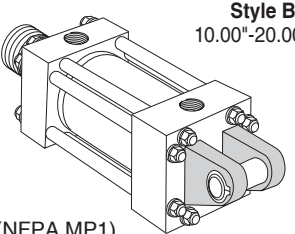
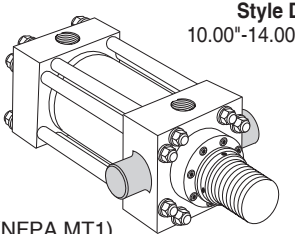
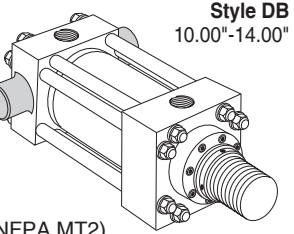
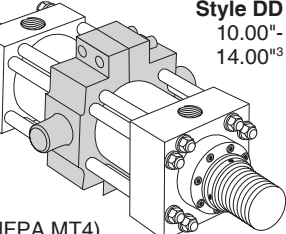
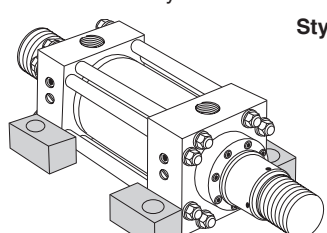
<p>Tie Rods Extended Head End</p>  <p><b>Style TB</b> 10.00"-14.00"</p> <p>(NFPA MX3)</p>	<p>Tie Rods Extended Cap End</p>  <p><b>Style TC</b> 10.00"-14.00"</p> <p>(NFPA MX2)</p>	<p>Tie Rods Extended Both Ends</p>  <p><b>Style TD</b> 10.00"-14.00"</p> <p>(NFPA MX1)</p>	<p>Head Rectangular</p>  <p><b>Style JJ</b> 10.00"-14.00"</p> <p>(NFPA ME5)</p>
<p>Head Square Flange</p>  <p><b>Style JB</b> 10.00"-20.00"</p> <p>(NFPA MF5)</p>	<p>Cap Rectangular</p>  <p><b>Style HH</b> 10.00"-20.00"</p> <p>(NFPA ME6)</p>	<p>Cap Square Flange</p>  <p><b>Style HB</b> 10.00"-20.00"</p> <p>(NFPA MF6)</p>	<p>Side Lug</p>  <p><b>Style C</b> 10.00"-14.00"</p> <p>(NFPA MS2)</p>
<p>Cap Fixed Clevis</p>  <p><b>Style BB</b> 10.00"-20.00"</p> <p>(NFPA MP1)</p>	<p>Head Trunnion</p>  <p><b>Style D</b> 10.00"-14.00"</p> <p>(NFPA MT1)</p>	<p>Cap Trunnion</p>  <p><b>Style DB</b> 10.00"-14.00"</p> <p>(NFPA MT2)</p>	<p>Intermediate Fixed Trunnion</p>  <p><b>Style DD</b> 10.00"-14.00"<sup>3</sup></p> <p>(NFPA MT4)</p>
<p>Double Rod Cylinders</p>  <p><b>Style KC Shown</b></p> <p>Most of the above illustrated mounting styles are available in double rod cylinders.</p>		<p><sup>3</sup> Consult factory for 16.00"-20.00"</p>	

PH Series 10.00" - 20.00"

**⚠ PROP 65 WARNING** WARNING: This product can expose you to chemicals including **Lead and Lead Compounds** which are known to the State of California to cause cancer and birth defects or other reproductive harm. For more information go to [www.P65Warnings.ca.gov](http://www.P65Warnings.ca.gov)

**Rod End Dimensions – 10.00" - 20.00" Bore**

**Thread Style 4 (NFPA Style SM)  
Small Male**

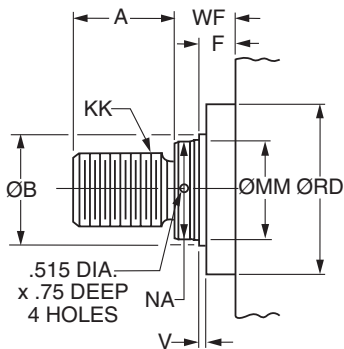

**Thread Style 55<sup>1</sup>  
Flanged Rod End**

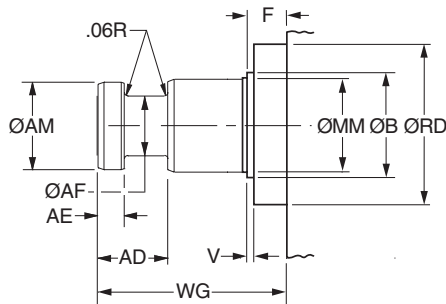

**Thread Style 9<sup>2</sup> (NFPA Style SF)  
Small Female**

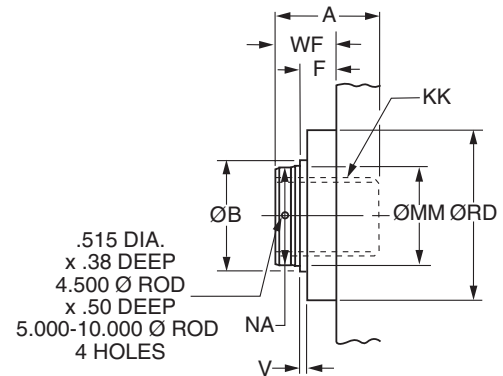

**Rod End Dimensions – 10.00" - 20.00" Bore**

Bore Ø	Rod No.	MM Rod Ø	Thread Style 4 & 9 KK	Rod Extensions and Pilot Dimensions						
				A	B Ø +.000 - .005	F	NA	RD -.005	V	WF
10.00	1 (std.)	4.500	3 1/4-12	4.50	5.249	1.94	4.38	8.249	0.25	2.94
	2	7.000	5-12	7.00	7.999	1.94	6.88	10.499	0.38	3.50
	3	5.000	3 1/2-12	5.00	5.749	1.94	4.88	8.874	0.25	3.19
	4	5.500	4-12	5.50	6.249	1.94	5.38	9.374	0.25	3.19
12.00	1 (std.)	5.500	4-12	5.50	6.249	1.94	5.38	9.374	0.25	3.19
	2	8.000	5 3/4-12	8.00	8.999	1.94	7.88	12.499	0.38	4.00
	3	7.000	5-12	7.00	7.999	1.94	6.88	10.499	0.38	3.50
14.00	1 (std.)	7.000	5-12	7.00	7.999	1.94	6.88	10.499	0.38	3.50
	2	10.000	7 1/4-12	10.00	10.999	1.94	9.88	14.499	0.38	4.50
	3	8.000	5 3/4-12	8.00	8.999	1.94	7.88	12.499	0.38	4.00
16.00	1	8.000	5 3/4-12	8.00	8.999	1.94	7.88	12.499	0.38	4.00
	3	9.000	6 1/2-12	9.00	9.999	1.94	8.88	13.499	0.38	4.25
	4	10.000	7 1/4-12	10.00	10.999	1.94	9.88	14.499	0.38	4.50
18.00	1	9.000	6 1/2-12	9.00	9.999	1.94	8.88	13.499	0.38	4.25
	3	10.000	7 1/4-12	10.00	10.999	1.94	9.88	14.499	0.38	4.50
20.00	1	10.000	7 1/4-12	10.00	10.999	1.94	9.88	14.499	0.38	4.50



**“Special” Thread Style 3**

Special thread, extension, rod eye, blank, etc., are also available.

To order, specify “Style 3” and give desired dimensions for KK, A & WF. If otherwise special, furnish dimensioned sketch.

<sup>1</sup>For special WG dimension, specify “Style 3” and give desired dimension for WG. For other changes, place “S” in the model code, and describe rod end with dimensioned sketch.

<sup>2</sup>Style 9 stroke restrictions may apply. See Style 9 Minimum Stroke Table on How to Order page for details.

**Style 55 Rod End**

MM Rod Ø	AD	AE +.001 - .001	AF Ø	AM Ø	WG <sup>1</sup>
4.500	3.19	1.499	3.50	4.45	6.50
5.000	3.19	1.499	3.88	4.95	6.63
5.500	3.94	1.874	4.38	5.45	7.50
7.000	4.06	1.999	5.75	6.95	8.44
8.000	4.06	1.999	6.50	7.95	8.69
9.000	4.63	2.374	7.25	8.95	8.75
10.000	4.63	2.374	8.00	9.95	9.75

**⚠ PROP 65 WARNING** WARNING: This product can expose you to chemicals including **Lead and Lead Compounds** which are known to the State of California to cause cancer and birth defects or other reproductive harm. For more information go to [www.P65Warnings.ca.gov](http://www.P65Warnings.ca.gov)

**Tie Rods Extended Both Ends Mounting**  
**Style TD**  
(NFPA Style MX1)

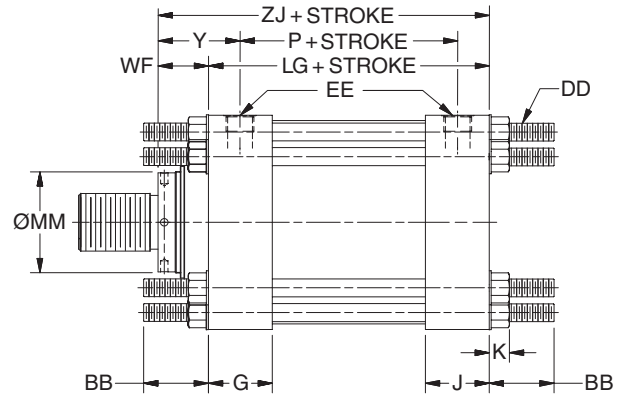
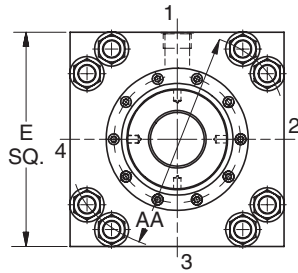
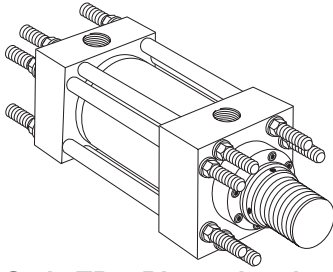

**Style TD – Dimensional and Mounting Data**

Bore Ø	Rod No.	MM Rod Ø	AA	BB	DD	E	EE			G	J	K Max.	WF	Y	Add Stroke		
							NPTF <sup>1</sup>	SAE Flange Ports <sup>2</sup>	SAE Straight Thread <sup>3</sup>						LG	P	ZJ
10.00	1 (std.)	4.500	13.00	4.13	1 1/8-12	12.63	2.00	2.00	24	3.69	3.69	1.17	2.94	4.75	12.13	8.50	15.06
	2	7.000	13.00	4.13	1 1/8-12	12.63	2.00	2.00	24	3.69	3.69	1.17	3.50	5.31	12.13	8.50	15.63
	3	5.000	13.00	4.13	1 1/8-12	12.63	2.00	2.00	24	3.69	3.69	1.17	3.19	5.00	12.13	8.50	15.31
	4	5.500	13.00	4.13	1 1/8-12	12.63	2.00	2.00	24	3.69	3.69	1.17	3.19	5.00	12.13	8.50	15.31
12.00	1 (std.)	5.500	15.50	4.50	1 1/4-12	14.88	2.50	2.50 <sup>4</sup>	24	4.44	4.44	1.30	3.19	5.38	14.50	10.13	17.69
	2	8.000	15.50	4.50	1 1/4-12	14.88	2.50	2.50 <sup>4</sup>	24	4.44	4.44	1.30	4.00	6.19	14.50	10.13	18.50
	3	7.000	15.50	4.50	1 1/4-12	14.88	2.50	2.50 <sup>4</sup>	24	4.44	4.44	1.30	3.50	5.69	14.50	10.13	18.00
14.00	1 (std.)	7.000	17.38	4.50	1 1/4-12	17.13	2.50	2.50 <sup>4</sup>	24	4.88	4.88	1.30	3.50	5.88	15.63	10.88	19.13
	2	10.000	17.38	4.50	1 1/4-12	17.13	2.50	2.50 <sup>4</sup>	24	4.88	4.88	1.30	4.50	6.88	15.63	10.88	20.13
	3	8.000	17.38	4.50	1 1/4-12	17.13	2.50	2.50 <sup>4</sup>	24	4.88	4.88	1.30	4.00	6.38	15.63	10.88	19.63

<sup>1</sup> NPTF ports are available at no extra charge.

<sup>2</sup> Optional SAE flange ports may be specified – flange to be supplied by customer. See Optional SAE Flange Port Pattern table for dimensions.

<sup>3</sup> SAE straight thread ports are standard and are indicated by port number.

<sup>4</sup> 2.50 SAE flange port is rated at 2500 psi

**Optional SAE Flange Port Pattern**

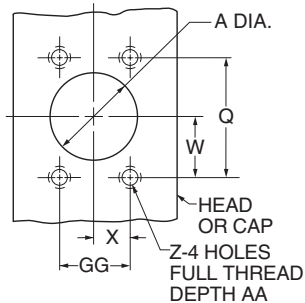

Nom. Flange Size	A	Q	GG	W	X	Z-THD UNC-2B	AA Min.	SAE
2	2.00	3.062	1.688	1.53	0.84	1/2-13	1.06	32
2 1/2	2.50	3.500	2.000	1.75	1.00	1/2-13	1.19	40

**Model 51 – Tie Rod Information**

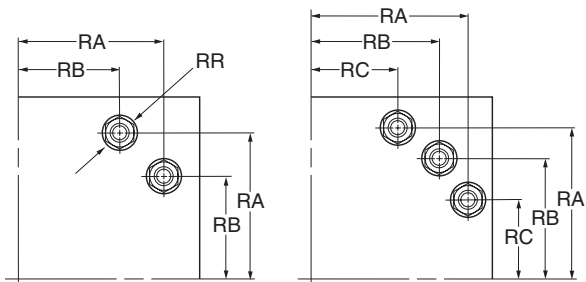

Bore Ø	10.00	12.00	14.00
Tie Rod Thread	1 1/8-12	1 1/4-12	1 1/4-12
RA	5.291	6.270	7.485
RB	3.775	4.555	6.143
RC	—	—	4.409
RR	2.00	2.19	2.19

**Style TB**

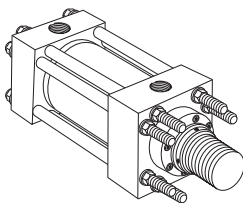

**Style TC**

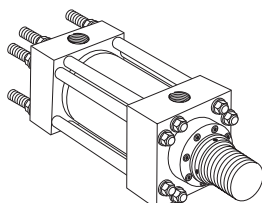

Dimensions for TB and TC may be obtained from the above dimensional table.

**⚠ PROP 65 WARNING** WARNING: This product can expose you to chemicals including **Lead and Lead Compounds** which are known to the State of California to cause cancer and birth defects or other reproductive harm. For more information go to [www.P65Warnings.ca.gov](http://www.P65Warnings.ca.gov)

PH Series  
10.00" - 20.00"

**Side Lugs Mounting**  
**Style C**  
(NFPA Style MS2)

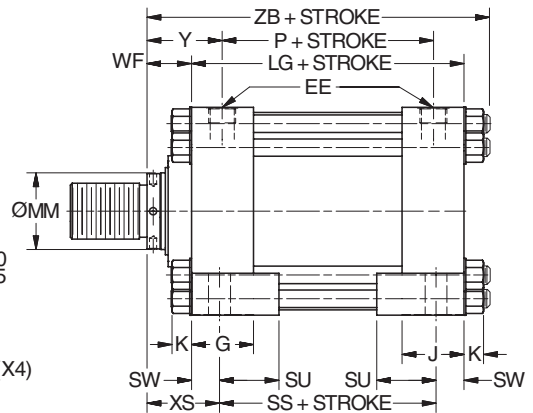
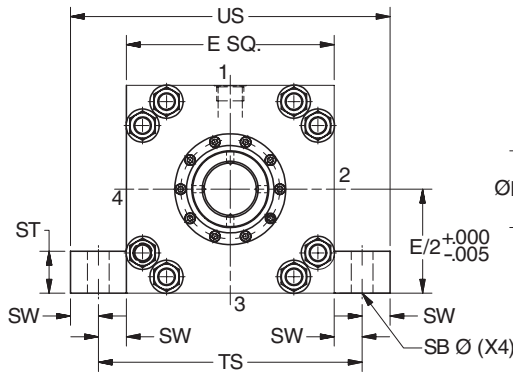
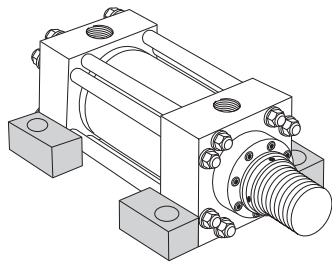

**Style C – Dimensional and Mounting Data**

Bore Ø	Rod No.	MM Rod Ø	E	Ports (EE)			G	J	K Max.	SB Ø	ST	SU	SW	Y	TS	US	WF	XS
				NPTF <sup>1</sup>	SAE Flange Port <sup>2</sup>	SAE Straight Thread Port <sup>3</sup>												
10.00	1 (std.)	4.500	12.63	2.00	2.00	24	3.69	3.69	1.17	1.563	2.25	3.50	1.63	4.75	15.88	19.13	2.94	4.56
	2	7.000	12.63	2.00	2.00	24	3.69	3.69	1.17	1.563	2.25	3.50	1.63	5.31	15.88	19.13	3.50	5.13
	3	5.000	12.63	2.00	2.00	24	3.69	3.69	1.17	1.563	2.25	3.50	1.63	5.00	15.88	19.13	3.19	4.81
	4	5.500	12.63	2.00	2.00	24	3.69	3.69	1.17	1.563	2.25	3.50	1.63	5.00	15.88	19.13	3.19	4.81
12.00	1 (std.)	5.500	14.88	2.50	2.50 <sup>4</sup>	24	4.44	4.44	1.30	1.563	3.00	4.25	2.00	5.38	18.88	22.88	3.19	5.19
	2	8.000	14.88	2.50	2.50 <sup>4</sup>	24	4.44	4.44	1.30	1.563	3.00	4.25	2.00	6.19	18.88	22.88	4.00	6.00
	3	7.000	14.88	2.50	2.50 <sup>4</sup>	24	4.44	4.44	1.30	1.563	3.00	4.25	2.00	5.69	18.88	22.88	3.50	5.50
14.00	1 (std.)	7.000	17.13	2.50	2.50 <sup>4</sup>	24	4.88	4.88	1.30	2.313	4.00	4.75	2.25	5.88	21.63	26.13	3.50	5.75
	2	10.000	17.13	2.50	2.50 <sup>4</sup>	24	4.88	4.88	1.30	2.313	4.00	4.75	2.25	6.88	21.63	26.13	4.50	6.75
	3	8.000	17.13	2.50	2.50 <sup>4</sup>	24	4.88	4.88	1.30	2.313	4.00	4.75	2.25	6.38	21.63	26.13	4.00	6.25

<sup>1</sup>NPTF ports are available at no extra charge.

<sup>2</sup>Optional SAE flange ports may be specified – flange to be supplied by customer. See Optional SAE Flange Port Pattern table for dimensions.

<sup>3</sup>SAE straight thread ports are standard and are indicated by port number.

<sup>4</sup>2.50 SAE flange port is rated at 2500 psi

**Style C – Dimensional and Mounting Data (cont.)**

Bore Ø	Rod No.	MM Rod Ø	Add Stroke			
			LG	P	SS	ZB Max.
10.00	1 (std.)	4.500	12.13	8.50	8.88	16.49
	2	7.000	12.13	8.50	8.88	17.05
	3	5.000	12.13	8.50	8.88	16.74
	4	5.500	12.13	8.50	8.88	16.74
12.00	1 (std.)	5.500	14.50	10.13	10.50	19.24
	2	8.000	14.50	10.13	10.50	20.05
	3	7.000	14.50	10.13	10.50	19.55
14.00	1 (std.)	7.000	15.63	10.88	11.13	20.68
	2	10.000	15.63	10.88	11.13	21.68
	3	8.000	15.63	10.88	11.13	21.18

**Optional SAE Flange Port Pattern**

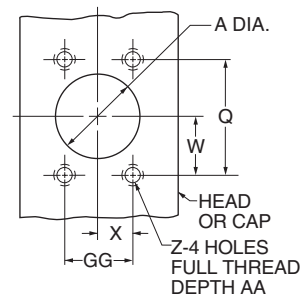

Nom. Flange Size	A	Q	GG	W	X	Z-THD UNC-2B	AA Min.	SAE
2	2.00	3.062	1.688	1.53	0.84	1/2-13	1.06	32
2 1/2	2.50	3.500	2.000	1.75	1.00	1/2-13	1.19	40

PH Series  
10.00" - 20.00"

**⚠ PROP 65 WARNING** WARNING: This product can expose you to chemicals including **Lead and Lead Compounds** which are known to the State of California to cause cancer and birth defects or other reproductive harm. For more information go to [www.P65Warnings.ca.gov](http://www.P65Warnings.ca.gov)

**Head Rectangular Mounting**

Style JJ

(NFFA Style ME5)

(10.00-14.00 Bore)

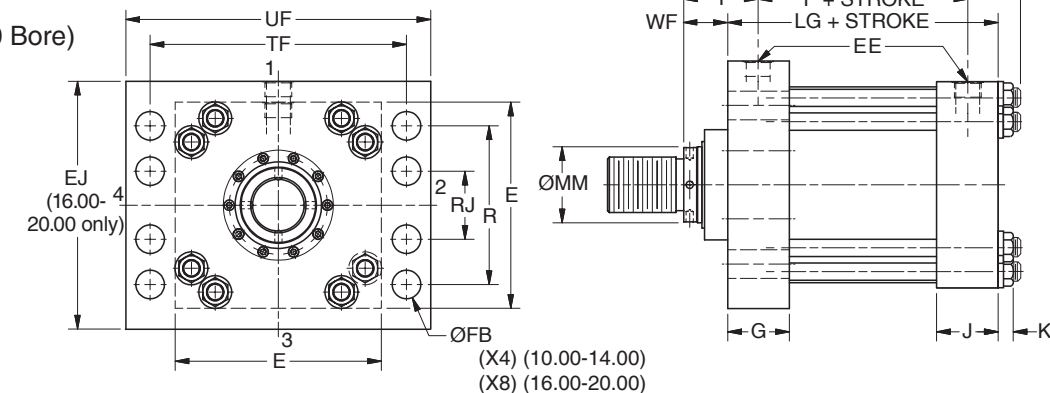
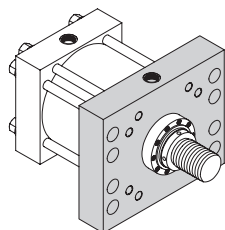
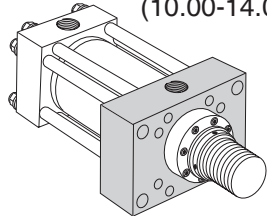

**Style JJ – Dimensional and Mounting Data**

Bore Ø	Rod No.	MM Rod Ø	E	EJ	Ports (EE)			FB Ø	G	J	K Max.	R	RJ	TF	UF	WF	Y	Add Stroke		
					NPTF <sup>1</sup>	SAE Flange Port <sup>2</sup>	SAE Straight Thread Port <sup>3</sup>											LG	P	ZB Max.
10.00	1 (std.)	4.500	12.63	-	2.00	2.00	24	1.81	3.69	3.69	1.17	9.62	-	15.88	19.00	2.94	4.75	12.13	8.50	16.49
	2	7.000	12.63	-	2.00	2.00	24	1.81	3.69	3.69	1.17	9.62	-	15.88	19.00	3.50	5.31	12.13	8.50	17.05
	3	5.000	12.63	-	2.00	2.00	24	1.81	3.69	3.69	1.17	9.62	-	15.88	19.00	3.19	5.00	12.13	8.50	16.74
	4	5.500	12.63	-	2.00	2.00	24	1.81	3.69	3.69	1.17	9.62	-	15.88	19.00	3.19	5.00	12.13	8.50	16.74
12.00	1 (std.)	5.500	14.88	-	2.50	2.50 <sup>4</sup>	24	2.06	4.44	4.44	1.30	11.45	-	18.50	22.00	3.19	5.38	14.50	10.13	19.24
	2	8.000	14.88	-	2.50	2.50 <sup>4</sup>	24	2.06	4.44	4.44	1.30	11.45	-	18.50	22.00	4.00	6.19	14.50	10.13	20.05
	3	7.000	14.88	-	2.50	2.50 <sup>4</sup>	24	2.06	4.44	4.44	1.30	11.45	-	18.50	22.00	3.50	5.69	14.50	10.13	19.55
14.00	1 (std.)	7.000	17.13	-	2.50	2.50 <sup>4</sup>	24	2.31	4.88	4.88	1.30	13.26	-	21.00	25.00	3.50	5.88	15.63	10.88	20.68
	2	10.000	17.13	-	2.50	2.50 <sup>4</sup>	24	2.31	4.88	4.88	1.30	13.26	-	21.00	25.00	4.50	6.88	15.63	10.88	21.68
	3	8.000	17.13	-	2.50	2.50 <sup>4</sup>	24	2.31	4.88	4.88	1.30	13.26	-	21.00	25.00	4.00	6.38	15.63	10.88	21.18
16.00	1 (std.)	8.000	19.00	20.00	-	3.00 <sup>5</sup>	24	1.81	5.88	5.88	1.70	15.50	8.00	21.00	24.50	4.00	7.00	18.13	12.13	24.08
	3	9.000	19.00	20.00	-	3.00 <sup>5</sup>	24	1.81	5.88	5.88	1.70	15.50	8.00	21.00	24.50	4.25	7.25	18.13	12.13	24.33
	4	10.000	19.00	20.00	-	3.00 <sup>5</sup>	24	1.81	5.88	5.88	1.70	15.50	8.00	21.00	24.50	4.50	7.50	18.13	12.13	24.58
18.00	1 (std.)	9.000	22.00	23.00	-	3.00 <sup>5</sup>	24	2.06	6.88	6.88	1.70	18.00	7.25	24.25	28.25	4.25	7.25	21.13	15.13	27.33
	3	10.000	22.00	23.00	-	3.00 <sup>5</sup>	24	2.06	6.88	6.88	1.70	18.00	7.25	24.25	28.25	4.50	7.50	21.13	15.13	27.58
20.00	1 (std.)	10.000	24.00	25.00	-	3.00 <sup>5</sup>	24	2.06	7.88	7.88	1.70	20.00	8.00	26.50	30.50	4.50	7.50	23.63	17.63	30.08

<sup>1</sup> NPTF ports are available at no extra charge.

<sup>2</sup> Optional SAE flange ports may be specified – flange to be supplied by customer. See Optional SAE Flange Port Pattern table for dimensions.

<sup>3</sup> SAE straight thread ports are standard and are indicated by port number.

<sup>4</sup> 2.50 SAE flange port is rated at 2500 psi

<sup>5</sup> 3.00 SAE flange port is rated at 2000 psi

**Optional SAE Flange Port Pattern**

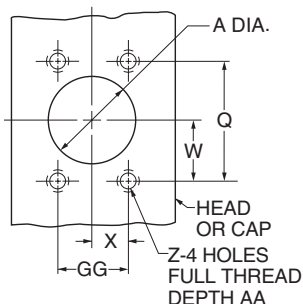

Nom. Flange Size	A	Q	GG	W	X	Z-THD UNC-2B	AA Min.	SAE
2	2.00	3.062	1.688	1.53	0.84	1/2-13	1.06	32
2 1/2	2.50	3.500	2.000	1.75	1.00	1/2-13	1.19	40
3	3.00	4.188	2.438	2.09	1.22	5/8-11	1.19	48

**PROP 65 WARNING** WARNING: This product can expose you to chemicals including **Lead and Lead Compounds** which are known to the State of California to cause cancer and birth defects or other reproductive harm. For more information go to [www.P65Warnings.ca.gov](http://www.P65Warnings.ca.gov)

PH Series  
10.00" - 20.00"



**Head Square Flange Mounting**  
**Style JB**  
**(NFFA Style MF5)**

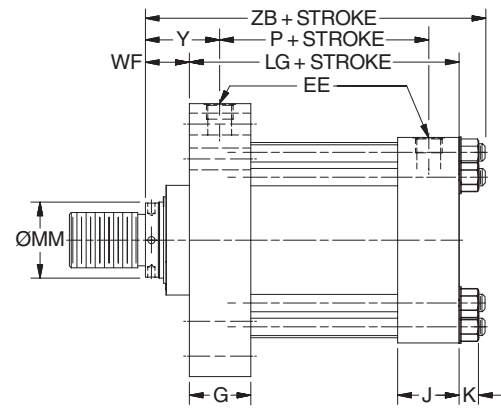
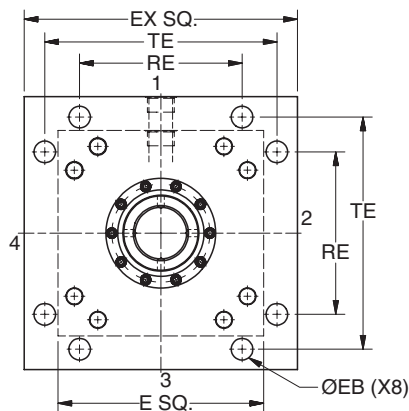
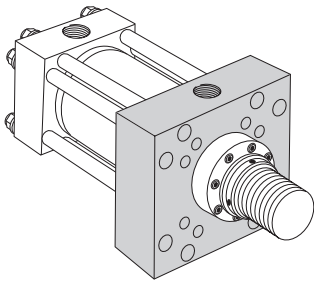

**Style JB – Dimensional and Mounting Data**

Bore Ø	MM Rod Ø	E	EB Ø	Ports (EE)			EX	G	J	K Max.	RE	TE	WF	Y	Add Stroke		
				NPTF <sup>1</sup>	SAE Flange Port <sup>2</sup>	SAE Straight Thread Port <sup>3</sup>									LG	P	ZB Max.
10.00	4.500	12.63	1.31	2.00	2.00	24	16.63	3.69	3.69	1.17	9.89	14.13	2.94	4.75	12.13	8.50	16.49
	5.000	12.63	1.31	2.00	2.00	24	16.63	3.69	3.69	1.17	9.89	14.13	3.19	5.00	12.13	8.50	16.74
	5.500	12.63	1.31	2.00	2.00	24	16.63	3.69	3.69	1.17	9.89	14.13	3.19	5.00	12.13	8.50	16.74
	7.000	12.63	1.31	2.00	2.00	24	16.63	3.69	3.69	1.17	9.89	14.13	3.50	5.31	12.13	8.50	17.05
12.00	5.500	14.88	1.56	2.50	2.50 <sup>4</sup>	24	19.75	4.44	4.44	1.30	11.75	16.79	3.19	5.38	14.50	10.13	19.24
	7.000	14.88	1.56	2.50	2.50 <sup>4</sup>	24	19.75	4.44	4.44	1.30	11.75	16.79	3.50	5.69	14.50	10.13	19.55
	8.000	14.88	1.56	2.50	2.50 <sup>4</sup>	24	19.75	4.44	4.44	1.30	11.75	16.79	4.00	6.19	14.50	10.13	20.05
14.00	7.000	17.13	1.81	2.50	2.50 <sup>4</sup>	24	21.75	4.88	4.88	1.30	12.90	18.43	3.50	5.88	15.63	10.88	20.68
	8.000	17.13	1.81	2.50	2.50 <sup>4</sup>	24	21.75	4.88	4.88	1.30	12.90	18.43	4.00	6.38	15.63	10.88	21.18
	10.000	17.13	1.81	2.50	2.50 <sup>4</sup>	24	21.75	4.88	4.88	1.30	12.90	18.43	4.50	6.88	15.63	10.88	21.68
16.00	8.000	19.00	1.81	-	3.00 <sup>5</sup>	24	24.50	5.88	5.88	1.70	15.28	21.03	4.00	7.00	18.13	12.13	24.08
	9.000	19.00	1.81	-	3.00 <sup>5</sup>	24	24.50	5.88	5.88	1.70	15.28	21.03	4.25	7.25	18.13	12.13	24.33
	10.000	19.00	1.81	-	3.00 <sup>5</sup>	24	24.50	5.88	5.88	1.70	15.28	21.03	4.50	7.50	18.13	12.13	24.58
18.00	9.000	22.00	2.06	-	3.00 <sup>5</sup>	24	26.50	6.88	6.88	1.70	16.45	22.65	4.25	7.25	21.13	15.13	27.33
	10.000	22.00	2.06	-	3.00 <sup>5</sup>	24	26.50	6.88	6.88	1.70	16.45	22.65	4.50	7.50	21.13	15.13	27.58
20.00	10.000	24.00	2.06	-	3.00 <sup>5</sup>	24	29.00	7.88	7.88	1.70	18.07	24.87	4.50	7.50	23.63	17.63	30.08

<sup>1</sup> NPTF ports are available at no extra charge.

<sup>2</sup> Optional SAE flange ports may be specified – flange to be supplied by customer. See Optional SAE Flange Port Pattern table for dimensions.

<sup>3</sup> SAE straight thread ports are standard and are indicated by port number.

<sup>4</sup> 2.50 SAE flange port is rated at 2500 psi

<sup>5</sup> 3.00 SAE flange port is rated at 2000 psi

**Optional SAE Flange Port Pattern**

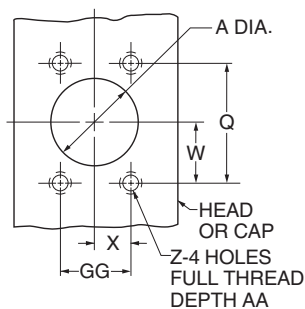

Nom. Flange Size	A	Q	GG	W	X	Z-THD UNC-2B	AA Min.	SAE
2	2.00	3.062	1.688	1.53	0.84	1/2-13	1.06	32
2 1/2	2.50	3.500	2.000	1.75	1.00	1/2-13	1.19	40
3	3.00	4.188	2.438	2.09	1.22	5/8-11	1.19	48

**⚠ PROP 65 WARNING** WARNING: This product can expose you to chemicals including **Lead and Lead Compounds** which are known to the State of California to cause cancer and birth defects or other reproductive harm. For more information go to [www.P65Warnings.ca.gov](http://www.P65Warnings.ca.gov)

**Cap Rectangular Mounting**  
**Style HH**  
**(NFPA Style ME6)**

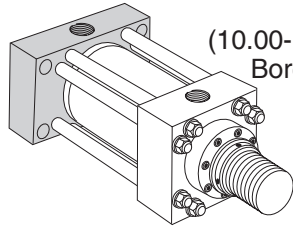

(10.00-14.00 Bore)

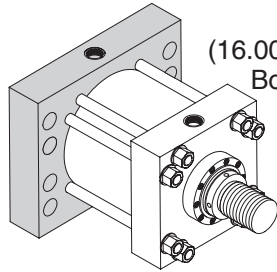

(16.00-20.00 Bore)

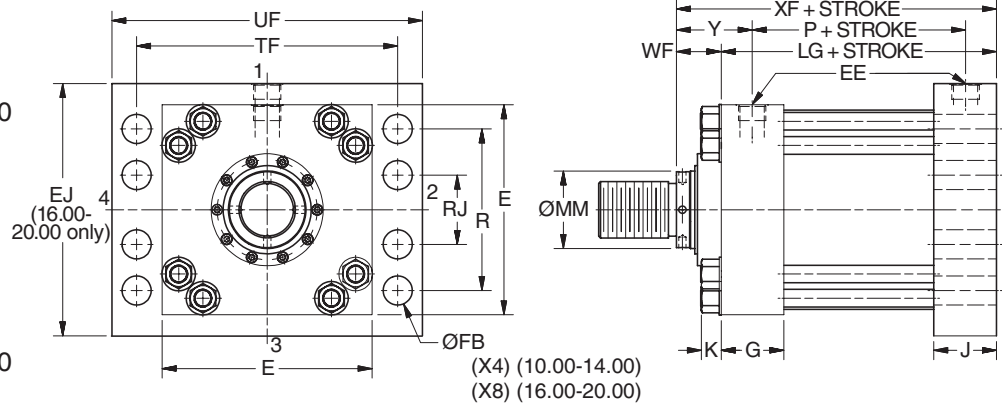

**Style HH – Dimensional and Mounting Data**

Bore Ø	MM Rod Ø	E	Ports (EE)			EJ	FB Ø	G	J	K Max.	R	RJ	TF	UF	WF	Y	Add Stroke		
			NPTF <sup>1</sup>	SAE Flange Port <sup>2</sup>	SAE Straight Thread Port <sup>3</sup>												LG	P	XF
10.00	4.500	12.63	2.00	2.00	24	-	1.81	3.69	3.69	1.17	9.62	-	15.88	19.00	2.94	4.75	12.13	8.50	15.06
	5.000	12.63	2.00	2.00	24	-	1.81	3.69	3.69	1.17	9.62	-	15.88	19.00	3.19	5.00	12.13	8.50	15.31
	5.500	12.63	2.00	2.00	24	-	1.81	3.69	3.69	1.17	9.62	-	15.88	19.00	3.19	5.00	12.13	8.50	15.31
	7.000	12.63	2.00	2.00	24	-	1.81	3.69	3.69	1.17	9.62	-	15.88	19.00	3.50	5.31	12.13	8.50	15.63
12.00	5.500	14.88	2.50	2.50 <sup>4</sup>	24	-	2.06	4.44	4.44	1.30	11.45	-	18.50	22.00	3.19	5.38	14.50	10.13	17.69
	7.000	14.88	2.50	2.50 <sup>4</sup>	24	-	2.06	4.44	4.44	1.30	11.45	-	18.50	22.00	3.50	5.69	14.50	10.13	18.00
	8.000	14.88	2.50	2.50 <sup>4</sup>	24	-	2.06	4.44	4.44	1.30	11.45	-	18.50	22.00	4.00	6.19	14.50	10.13	18.50
14.00	7.000	17.13	2.50	2.50 <sup>4</sup>	24	-	2.31	4.88	4.88	1.30	13.26	-	21.00	25.00	3.50	5.88	15.63	10.88	19.13
	8.000	17.13	2.50	2.50 <sup>4</sup>	24	-	2.31	4.88	4.88	1.30	13.26	-	21.00	25.00	4.00	6.38	15.63	10.88	19.63
	10.000	17.13	2.50	2.50 <sup>4</sup>	24	-	2.31	4.88	4.88	1.30	13.26	-	21.00	25.00	4.50	6.88	15.63	10.88	20.13
16.00	8.000	19.00	-	3.00 <sup>5</sup>	24	20.00	1.81	5.88	5.88	1.70	15.50	8.00	21.00	24.50	4.00	7.00	18.13	12.13	22.13
	9.000	19.00	-	3.00 <sup>5</sup>	24	20.00	1.81	5.88	5.88	1.70	15.50	8.00	21.00	24.50	4.25	7.25	18.13	12.13	22.38
	10.000	19.00	-	3.00 <sup>5</sup>	24	20.00	1.81	5.88	5.88	1.70	15.50	8.00	21.00	24.50	4.50	7.50	18.13	12.13	22.63
18.00	9.000	22.00	-	3.00 <sup>5</sup>	24	23.00	2.06	6.88	6.88	1.70	18.00	7.25	24.25	28.25	4.25	7.25	21.13	15.13	25.38
	10.000	22.00	-	3.00 <sup>5</sup>	24	23.00	2.06	6.88	6.88	1.70	18.00	7.25	24.25	28.25	4.50	7.50	21.13	15.13	25.63
20.00	10.000	24.00	-	3.00 <sup>5</sup>	24	25.00	2.06	7.88	7.88	1.70	20.00	8.00	26.50	30.50	4.50	7.50	23.63	17.63	28.13

<sup>1</sup>NPTF ports are available at no extra charge.

<sup>2</sup>Optional SAE flange ports may be specified – flange to be supplied by customer. See Optional SAE Flange Port Pattern table for dimensions.

<sup>3</sup>SAE straight thread ports are standard and are indicated by port number.

<sup>4</sup> 2.50 SAE flange port is rated at 2500 psi

<sup>5</sup> 3.00 SAE flange port is rated at 2000 psi

**Optional SAE Flange Port Pattern**

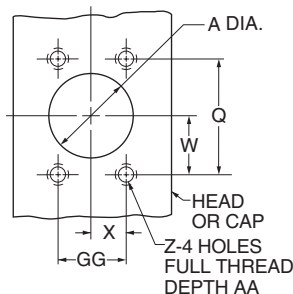

Nom. Flange Size	A	Q	GG	W	X	Z-THD UNC-2B	AA Min.	SAE
2	2.00	3.062	1.688	1.53	0.84	1/2-13	1.06	32
2 1/2	2.50	3.500	2.000	1.75	1.00	1/2-13	1.19	40
3	3.00	4.188	2.438	2.09	1.22	5/8-11	1.19	48

**⚠ PROP 65 WARNING** **WARNING:** This product can expose you to chemicals including **Lead and Lead Compounds** which are known to the State of California to cause cancer and birth defects or other reproductive harm. For more information go to [www.P65Warnings.ca.gov](http://www.P65Warnings.ca.gov)

PH Series  
 10.00" - 20.00"

**Cap Square Flange Mounting**  
**Style HB**  
**(NFPA Style MF6)**

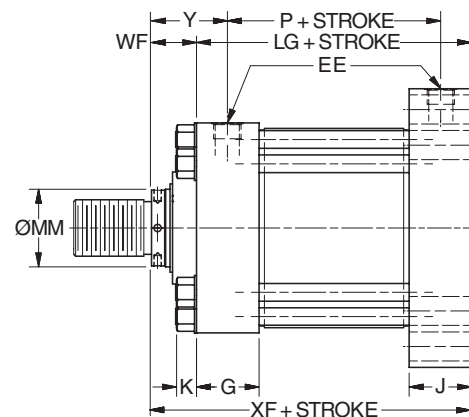
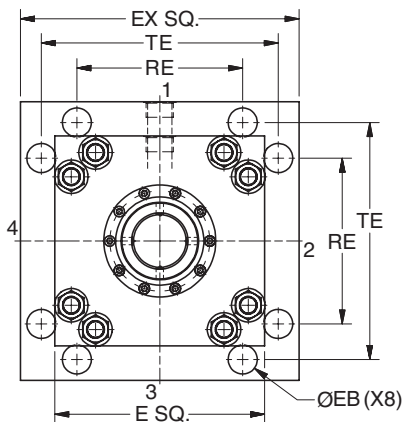
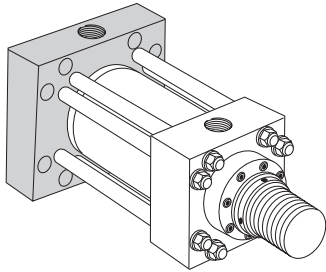

**Style HB – Dimensional and Mounting Data**

Bore Ø	MM Rod Ø	E	EB Ø	Ports (EE)			EX	G	J	K Max.	RE	TE	WF	Y	Add Stroke		
				NPTF <sup>1</sup>	SAE Flange Port <sup>2</sup>	SAE Straight Thread Port <sup>3</sup>									LG	P	XF
10.00	4.500	12.63	1.31	2.00	2.00	24	16.63	3.69	3.69	1.17	9.89	14.13	2.94	4.75	12.13	8.50	15.06
	5.000	12.63	1.31	2.00	2.00	24	16.63	3.69	3.69	1.17	9.89	14.13	3.19	5.00	12.13	8.50	15.31
	5.500	12.63	1.31	2.00	2.00	24	16.63	3.69	3.69	1.17	9.89	14.13	3.19	5.00	12.13	8.50	15.31
	7.000	12.63	1.31	2.00	2.00	24	16.63	3.69	3.69	1.17	9.89	14.13	3.50	5.31	12.13	8.50	15.63
12.00	5.500	14.88	1.56	2.50	2.50 <sup>4</sup>	24	19.75	4.44	4.44	1.30	11.75	16.79	3.19	5.38	14.50	10.13	17.69
	7.000	14.88	1.56	2.50	2.50 <sup>4</sup>	24	19.75	4.44	4.44	1.30	11.75	16.79	3.50	5.69	14.50	10.13	18.00
	8.000	14.88	1.56	2.50	2.50 <sup>4</sup>	24	19.75	4.44	4.44	1.30	11.75	16.79	4.00	6.19	14.50	10.13	18.50
14.00	7.000	17.13	1.81	2.50	2.50 <sup>4</sup>	24	21.75	4.88	4.88	1.30	12.90	18.43	3.50	5.88	15.63	10.88	19.13
	8.000	17.13	1.81	2.50	2.50 <sup>4</sup>	24	21.75	4.88	4.88	1.30	12.90	18.43	4.00	6.38	15.63	10.88	19.63
	10.000	17.13	1.81	2.50	2.50 <sup>4</sup>	24	21.75	4.88	4.88	1.30	12.90	18.43	4.50	6.88	15.63	10.88	20.13
16.00	8.000	19.00	1.81	-	3.00 <sup>5</sup>	24	24.50	5.88	5.88	1.70	15.28	21.03	4.00	7.00	18.13	12.13	22.13
	9.000	19.00	1.81	-	3.00 <sup>5</sup>	24	24.50	5.88	5.88	1.70	15.28	21.03	4.25	7.25	18.13	12.13	22.38
	10.000	19.00	1.81	-	3.00 <sup>5</sup>	24	24.50	5.88	5.88	1.70	15.28	21.03	4.50	7.50	18.13	12.13	22.63
18.00	9.000	22.00	2.06	-	3.00 <sup>5</sup>	24	26.50	6.88	6.88	1.70	16.45	22.65	4.25	7.25	21.13	15.13	25.38
	10.000	22.00	2.06	-	3.00 <sup>5</sup>	24	26.50	6.88	6.88	1.70	16.45	22.65	4.50	7.50	21.13	15.13	25.63
20.00	10.000	24.00	2.06	-	3.00 <sup>5</sup>	24	29.00	7.88	7.88	1.70	18.07	24.87	4.50	7.50	23.63	17.63	28.13

<sup>1</sup>NPTF ports are available at no extra charge.

<sup>2</sup>Optional SAE flange ports may be specified – flange to be supplied by customer. See Optional SAE Flange Port Pattern table for dimensions.

<sup>3</sup>SAE straight thread ports are standard and are indicated by port number.

<sup>4</sup> 2.50 SAE flange port is rated at 2500 psi

<sup>5</sup> 3.00 SAE flange port is rated at 2000 psi

**Optional SAE Flange Port Pattern**

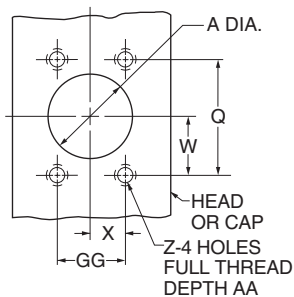

Nom. Flange Size	A	Q	GG	W	X	Z-THD UNC-2B	AA Min.	SAE
2	2.00	3.062	1.688	1.53	0.84	1/2-13	1.06	32
2 1/2	2.50	3.500	2.000	1.75	1.00	1/2-13	1.19	40
3	3.00	4.188	2.438	2.09	1.22	5/8-11	1.19	48

PH Series  
10.00" - 20.00"

**⚠ PROP 65 WARNING** WARNING: This product can expose you to chemicals including **Lead and Lead Compounds** which are known to the State of California to cause cancer and birth defects or other reproductive harm. For more information go to [www.P65Warnings.ca.gov](http://www.P65Warnings.ca.gov)

**Cap Fixed Clevis Mounting**  
**Style BB**  
**(NFPA Style MP1)**

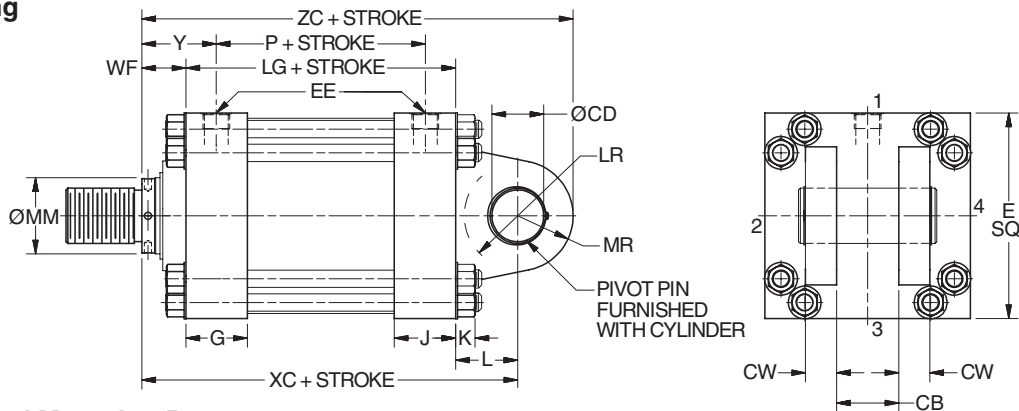
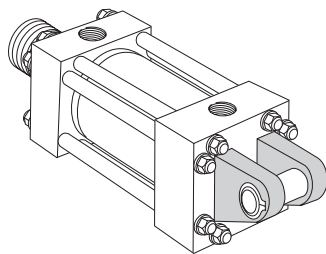

**Style BB – Dimensional and Mounting Data**

Bore Ø	MM Rod Ø	CB	CD <sup>4</sup> Ø +.000 - .002	CW	E	EE Ports			G	J	K Max.	L	LR	MR	WF	Y	Add Stroke			
						NPTF <sup>1</sup>	SAE Flange Port <sup>2</sup>	SAE Straight Thread Port <sup>3</sup>									LG	P	XC	ZC
10.00	4.500	4.00	3.501	2.00	12.63	2.00	2.00	24	3.69	3.69	1.17	4.00	3.38	3.50	2.94	4.75	12.13	8.50	19.06	22.56
	5.000	4.00	3.501	2.00	12.63	2.00	2.00	24	3.69	3.69	1.17	4.00	3.38	3.50	3.19	5.00	12.13	8.50	19.31	22.81
	5.500	4.00	3.501	2.00	12.63	2.00	2.00	24	3.69	3.69	1.17	4.00	3.38	3.50	3.19	5.00	12.13	8.50	19.31	22.81
	7.000	4.00	3.501	2.00	12.63	2.00	2.00	24	3.69	3.69	1.17	4.00	3.38	3.50	3.50	5.31	12.13	8.50	19.63	23.13
12.00	5.500	4.50	4.001	2.25	14.88	2.50	2.50 <sup>5</sup>	24	4.44	4.44	1.30	4.50	3.88	4.00	3.19	5.38	14.50	10.13	22.19	26.19
	7.000	4.50	4.001	2.25	14.88	2.50	2.50 <sup>5</sup>	24	4.44	4.44	1.30	4.50	3.88	4.00	3.50	5.69	14.50	10.13	22.50	26.50
	8.000	4.50	4.001	2.25	14.88	2.50	2.50 <sup>5</sup>	24	4.44	4.44	1.30	4.50	3.88	4.00	4.00	6.19	14.50	10.13	23.00	27.00
14.00	7.000	6.00	5.001	3.00	17.13	2.50	2.50 <sup>5</sup>	24	4.88	4.88	1.30	5.75	4.19	5.00	3.50	5.88	15.63	10.88	24.88	29.88
	8.000	6.00	5.001	3.00	17.13	2.50	2.50 <sup>5</sup>	24	4.88	4.88	1.30	5.75	4.19	5.00	4.00	6.38	15.63	10.88	25.38	30.38
	10.000	6.00	5.001	3.00	17.13	2.50	2.50 <sup>5</sup>	24	4.88	4.88	1.30	5.75	4.19	5.00	4.50	6.88	15.63	10.88	25.88	30.88
16.00	8.000	7.00	6.001	3.50	19.00	-	3.00 <sup>6</sup>	24	5.88	5.88	1.70	7.00	6.25	6.00	4.00	7.00	18.13	12.13	29.13	35.13
	9.000	7.00	6.001	3.50	19.00	-	3.00 <sup>6</sup>	24	5.88	5.88	1.70	7.00	6.25	6.00	4.25	7.25	18.13	12.13	29.38	35.38
	10.000	7.00	6.001	3.50	19.00	-	3.00 <sup>6</sup>	24	5.88	5.88	1.70	7.00	6.25	6.00	4.50	7.50	18.13	12.13	29.63	35.63
18.00	9.000	8.00	6.501	4.00	22.00	-	3.00 <sup>6</sup>	24	6.88	6.88	1.70	7.63	6.75	6.50	4.25	7.25	21.13	15.13	33.00	39.50
	10.000	8.00	6.501	4.00	22.00	-	3.00 <sup>6</sup>	24	6.88	6.88	1.70	7.63	6.75	6.50	4.50	7.50	21.13	15.13	33.25	39.75
20.00	10.000	9.00	7.501	4.50	24.00	-	3.00 <sup>6</sup>	24	7.88	7.88	1.70	8.75	7.75	7.50	4.50	7.50	23.63	17.63	36.88	44.38

<sup>1</sup>NPTF ports are available at no extra charge.

<sup>2</sup>Optional SAE flange ports may be specified – flange to be supplied by customer. See Optional SAE Flange Port Pattern table for dimensions.

<sup>3</sup>SAE straight thread ports are standard and are indicated by port number.

<sup>4</sup> Diameter CD is pin diameter.

<sup>5</sup> 2.50 SAE flange port is rated at 2500 psi

<sup>6</sup> 3.00 SAE flange port is rated at 2000 psi

**Optional SAE Flange Port Pattern**

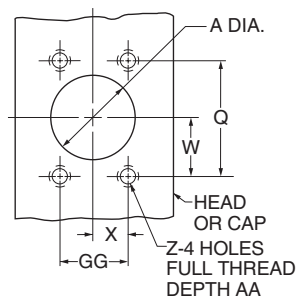

Nom. Flange Size	A	Q	GG	W	X	Z-THD UNC-2B	AA Min.	SAE
2	2.00	3.062	1.688	1.53	0.84	1/2-13	1.06	32
2 1/2	2.50	3.500	2.000	1.75	1.00	1/2-13	1.19	40
3	3.00	4.188	2.438	2.09	1.22	5/8-11	1.19	48

**PROP 65 WARNING** WARNING: This product can expose you to chemicals including **Lead and Lead Compounds** which are known to the State of California to cause cancer and birth defects or other reproductive harm. For more information go to [www.P65Warnings.ca.gov](http://www.P65Warnings.ca.gov)

**Head Trunnion Mounting**  
**Style D**  
**(NFPA Style MT1)**

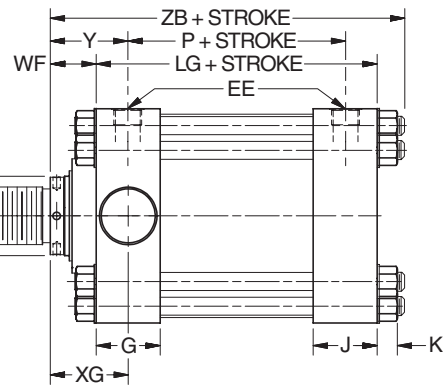
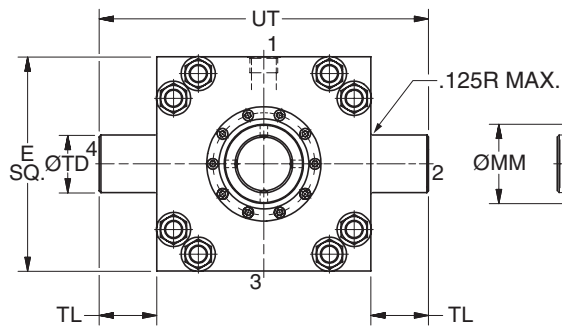
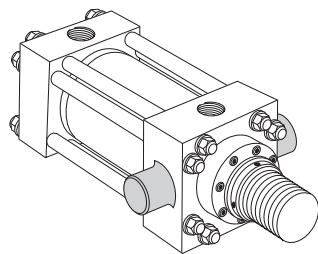

**Style D – Dimensional and Mounting Data**

Bore Ø	MM Rod Ø	E	Ports (EE)			G	J	K Max.	TD Ø +.000 -.001	TL	UT	WF	XG	Y	Add Stroke		
			NPTF <sup>1</sup>	SAE Flange Port <sup>2</sup>	SAE Straight Thread Port <sup>3</sup>										LG	P	ZB Max.
10.00	4.500	12.63	2.00	2.00	24	3.69	3.69	1.17	3.500	3.50	19.63	2.94	4.75	4.75	12.13	8.50	16.49
	5.000	12.63	2.00	2.00	24	3.69	3.69	1.17	3.500	3.50	19.63	3.19	5.00	5.00	12.13	8.50	16.74
	5.500	12.63	2.00	2.00	24	3.69	3.69	1.17	3.500	3.50	19.63	3.19	5.00	5.00	12.13	8.50	16.74
	7.000	12.63	2.00	2.00	24	3.69	3.69	1.17	3.500	3.50	19.63	3.50	5.31	5.31	12.13	8.50	17.05
12.00	5.500	14.88	2.50	2.50 <sup>4</sup>	24	4.44	4.44	1.30	4.000	4.00	22.88	3.19	5.38	5.38	14.50	10.13	19.24
	7.000	14.88	2.50	2.50 <sup>4</sup>	24	4.44	4.44	1.30	4.000	4.00	22.88	3.50	5.69	5.69	14.50	10.13	19.55
	8.000	14.88	2.50	2.50 <sup>4</sup>	24	4.44	4.44	1.30	4.000	4.00	22.88	4.00	6.19	6.19	14.50	10.13	20.05
14.00	7.000	17.13	2.50	2.50 <sup>4</sup>	24	4.88	4.88	1.30	4.500	4.50	26.13	3.50	5.94	5.88	15.63	10.88	20.68
	8.000	17.13	2.50	2.50 <sup>4</sup>	24	4.88	4.88	1.30	4.500	4.50	26.13	4.00	6.44	6.38	15.63	10.88	21.18
	10.000	17.13	2.50	2.50 <sup>4</sup>	24	4.88	4.88	1.30	4.500	4.50	26.13	4.50	6.94	6.88	15.63	10.88	21.68

<sup>1</sup> NPTF ports are available at no extra charge.

<sup>2</sup> Optional SAE flange ports may be specified – flange to be supplied by customer. See Optional SAE Flange Port Pattern table for dimensions.

<sup>3</sup> SAE straight thread ports are standard and are indicated by port number.

<sup>4</sup> 2.50 SAE flange port is rated at 2500 psi

**Style D – Maximum Operating Pressure**

Bore Ø	psi
10.00	2800
12.00	2350
14.00	2200

**Optional SAE Flange Port Pattern**

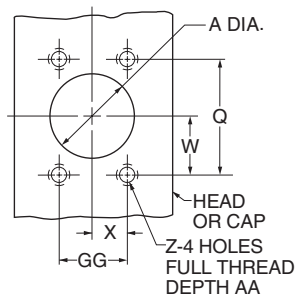

Nom. Flange Size	A	Q	GG	W	X	Z-THD UNC-2B	AA Min.	SAE
2	2.00	3.062	1.688	1.53	0.84	1/2-13	1.06	32
2 1/2	2.50	3.500	2.000	1.75	1.00	1/2-13	1.19	40

PH Series  
10.00" - 20.00"

**⚠ PROP 65 WARNING** WARNING: This product can expose you to chemicals including **Lead and Lead Compounds** which are known to the State of California to cause cancer and birth defects or other reproductive harm. For more information go to [www.P65Warnings.ca.gov](http://www.P65Warnings.ca.gov)

**Cap Trunnion Mounting**  
 Style DB  
 (NFA Style MT2)

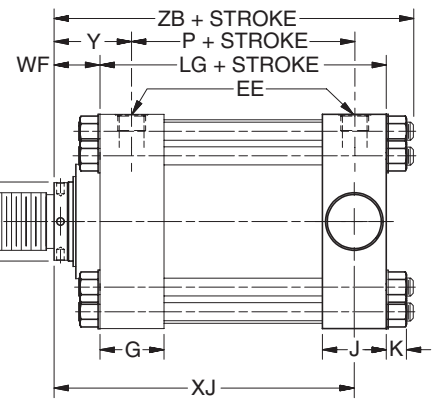
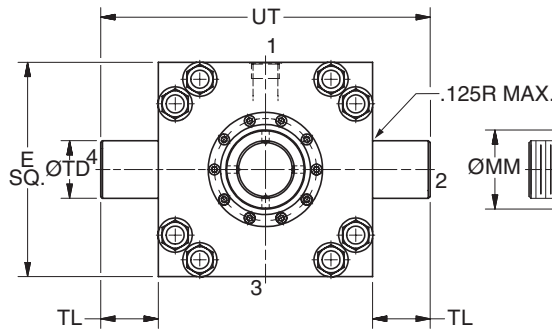
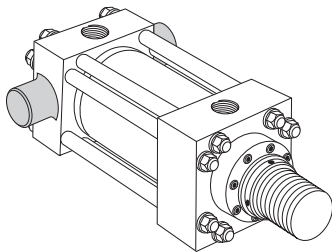

**Style DB – Dimensional and Mounting Data**

Bore Ø	MM Rod Ø	E	Ports (EE)			G	J	K Max.	TD Ø +.000 - .001	TL	UT	WF	Y	Add Stroke			
			NPTF <sup>1</sup>	SAE Flange Port <sup>2</sup>	SAE Straight Thread Port <sup>3</sup>									LG	P	XJ	ZB Max.
10.00	4.500	12.63	2.00	2.00	24	3.69	3.69	1.17	3.500	3.50	19.63	2.94	4.75	12.13	8.50	13.38	16.49
	5.000	12.63	2.00	2.00	24	3.69	3.69	1.17	3.500	3.50	19.63	3.19	5.00	12.13	8.50	13.63	16.74
	5.500	12.63	2.00	2.00	24	3.69	3.69	1.17	3.500	3.50	19.63	3.19	5.00	12.13	8.50	13.63	16.74
	7.000	12.63	2.00	2.00	24	3.69	3.69	1.17	3.500	3.50	19.63	3.50	5.31	12.13	8.50	13.94	17.05
12.00	5.500	14.88	2.50	2.50 <sup>4</sup>	24	4.44	4.44	1.30	4.000	4.00	22.88	3.19	5.38	14.50	10.13	15.50	19.24
	7.000	14.88	2.50	2.50 <sup>4</sup>	24	4.44	4.44	1.30	4.000	4.00	22.88	3.50	5.69	14.50	10.13	15.81	19.55
	8.000	14.88	2.50	2.50 <sup>4</sup>	24	4.44	4.44	1.30	4.000	4.00	22.88	4.00	6.19	14.50	10.13	16.31	20.05
14.00	7.000	17.13	2.50	2.50 <sup>4</sup>	24	4.88	4.88	1.30	4.500	4.50	26.13	3.50	5.88	15.63	10.88	16.69	20.68
	8.000	17.13	2.50	2.50 <sup>4</sup>	24	4.88	4.88	1.30	4.500	4.50	26.13	4.00	6.38	15.63	10.88	17.19	21.18
	10.000	17.13	2.50	2.50 <sup>4</sup>	24	4.88	4.88	1.30	4.500	4.50	26.13	4.50	6.88	15.63	10.88	17.69	21.68

<sup>1</sup> NPTF ports are available at no extra charge.

<sup>2</sup> Optional SAE flange ports may be specified – flange to be supplied by customer. See Optional SAE Flange Port Pattern table for dimensions.

<sup>3</sup> SAE straight thread ports are standard and are indicated by port number.

<sup>4</sup> 2.50 SAE flange port is rated at 2500 psi

**Optional SAE Flange Port Pattern**

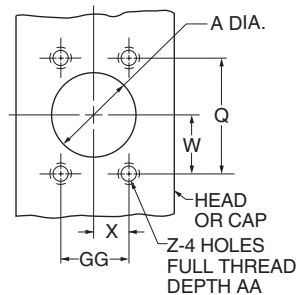

Nom. Flange Size	A	Q	GG	W	X	Z-THD UNC-2B	AA Min.	SAE
2	2.00	3.062	1.688	1.53	0.84	1/2-13	1.06	32
2 1/2	2.50	3.500	2.000	1.75	1.00	1/2-13	1.19	40

**Style DB – Maximum Operating Pressure**

Bore Ø	psi
10.00	2800
12.00	2350
14.00	2200

**⚠ PROP 65 WARNING** WARNING: This product can expose you to chemicals including **Lead and Lead Compounds** which are known to the State of California to cause cancer and birth defects or other reproductive harm. For more information go to [www.P65Warnings.ca.gov](http://www.P65Warnings.ca.gov)

**Intermediate Fixed Trunnion Mounting**  
**Style DD**  
**(NFA Style MT4)**

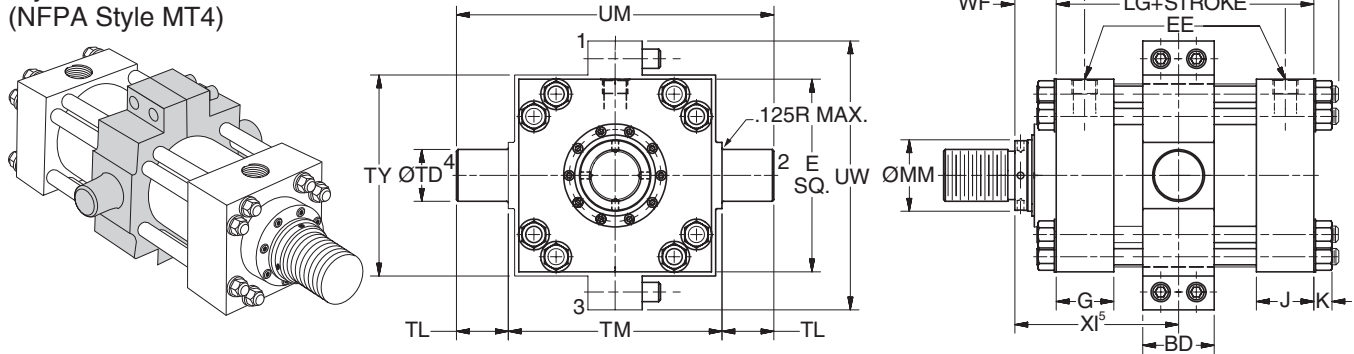

**Style DD – Dimensional and Mounting Data**

Bore Ø	MM Rod Ø	E	EE Ports			BD	G	J	K Max.	TD Ø +.000 -.001	TL	TM	TY	UM	UW	WF	Min. XI <sup>5</sup> Styles 2 & 4	Y	Add Stroke		
			NPTF <sup>1</sup>	SAE Flge. Port <sup>2</sup>	SAE Str. Thr. Port <sup>3</sup>														LG	P	ZB Max.
10.00	4.500	12.63	2.00	2.00	24	4.50	3.69	3.69	1.17	3.500	3.50	14.00	13.00	21.00	17.50	2.94	9.06	4.75	12.13	8.50	16.49
	5.000	12.63	2.00	2.00	24	4.50	3.69	3.69	1.17	3.500	3.50	14.00	13.00	21.00	17.50	3.19	9.31	5.00	12.13	8.50	16.74
	5.500	12.63	2.00	2.00	24	4.50	3.69	3.69	1.17	3.500	3.50	14.00	13.00	21.00	17.50	3.19	9.31	5.00	12.13	8.50	16.74
	7.000	12.63	2.00	2.00	24	4.50	3.69	3.69	1.17	3.500	3.50	14.00	13.00	21.00	17.50	3.50	9.63	5.31	12.13	8.50	17.05
12.00	5.500	14.88	2.50	2.50 <sup>6</sup>	24	5.50	4.44	4.44	1.30	4.000	4.00	16.50	15.50	24.50	20.75	3.19	10.63	5.38	14.50	10.13	19.24
	7.000	14.88	2.50	2.50 <sup>6</sup>	24	5.50	4.44	4.44	1.30	4.000	4.00	16.50	15.50	24.50	20.75	3.50	10.94	5.69	14.50	10.13	19.55
	8.000	14.88	2.50	2.50 <sup>6</sup>	24	5.50	4.44	4.44	1.30	4.000	4.00	16.50	15.50	24.50	20.75	4.00	11.50	6.19	14.50	10.13	20.05
14.00	7.000	17.13	2.50	2.50 <sup>6</sup>	24	5.50	4.88	4.88	1.30	4.500	4.50	19.50	19.25	28.50	24.75	3.50	11.44	5.88	15.63	10.88	20.68
	8.000	17.13	2.50	2.50 <sup>6</sup>	24	5.50	4.88	4.88	1.30	4.500	4.50	19.50	19.25	28.50	24.75	4.00	11.94	6.38	15.63	10.88	21.18
	10.000	17.13	2.50	2.50 <sup>6</sup>	24	5.50	4.88	4.88	1.30	4.500	4.50	19.50	19.25	28.50	24.75	4.50	12.44	6.88	15.63	10.88	21.68
16.00	8.000	19.00	4	3.00 <sup>7</sup>	24	4	5.88	5.88	1.70	4	4	4	4	4	4	4.00	4	7.00	18.13	12.13	24.08
	9.000	19.00	4	3.00 <sup>7</sup>	24	4	5.88	5.88	1.70	4	4	4	4	4	4	4.25	4	7.25	18.13	12.13	24.33
	10.000	19.00	4	3.00 <sup>7</sup>	24	4	5.88	5.88	1.70	4	4	4	4	4	4	4.50	4	7.50	18.13	12.13	24.58
18.00	9.000	22.00	4	3.00 <sup>7</sup>	24	4	6.88	6.88	1.70	4	4	4	4	4	4	4.25	4	7.25	21.13	15.13	27.33
	10.000	22.00	4	3.00 <sup>7</sup>	24	4	6.88	6.88	1.70	4	4	4	4	4	4	4.50	4	7.50	21.13	15.13	27.58
20.00	10.000	24.00	4	3.00 <sup>7</sup>	24	4	7.88	7.88	1.70	4	4	4	4	4	4	4.50	4	7.50	23.63	17.63	30.08

<sup>1</sup>NPTF ports are available at no extra charge.

<sup>2</sup>Optional SAE flange ports may be specified – flange to be supplied by customer. See Optional SAE Flange Port Pattern table for dimensions.

<sup>3</sup>SAE straight thread ports are standard and are indicated by port number.

<sup>4</sup>Consult Factory

<sup>5</sup>Dimension XI to be specified by customer. Reference point for rod end Style 9 is end of piston rod.

<sup>6</sup>2.50 SAE flange port is rated at 2500 psi

<sup>7</sup>3.00 SAE flange port is rated at 2000 psi

**Optional SAE Flange Port Pattern**

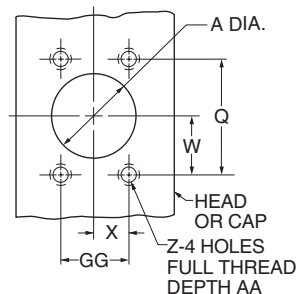

Nom. Flange Size	A	Q	GG	W	X	Z-THD UNC-2B	AA Min.	SAE
2	2.00	3.062	1.688	1.53	0.84	1/2-13	1.06	32
2 1/2	2.50	3.500	2.000	1.75	1.00	1/2-13	1.19	40
3	3.00	4.188	2.438	2.09	1.22	5/8-11	1.19	48

**Style DD – Maximum Operating Pressure**

Bore Ø	psi
10.00	2800
12.00	2350
14.00	2200

**⚠ PROP 65 WARNING** WARNING: This product can expose you to chemicals including **Lead and Lead Compounds** which are known to the State of California to cause cancer and birth defects or other reproductive harm. For more information go to [www.P65Warnings.ca.gov](http://www.P65Warnings.ca.gov)

**Double Rod Cylinder**

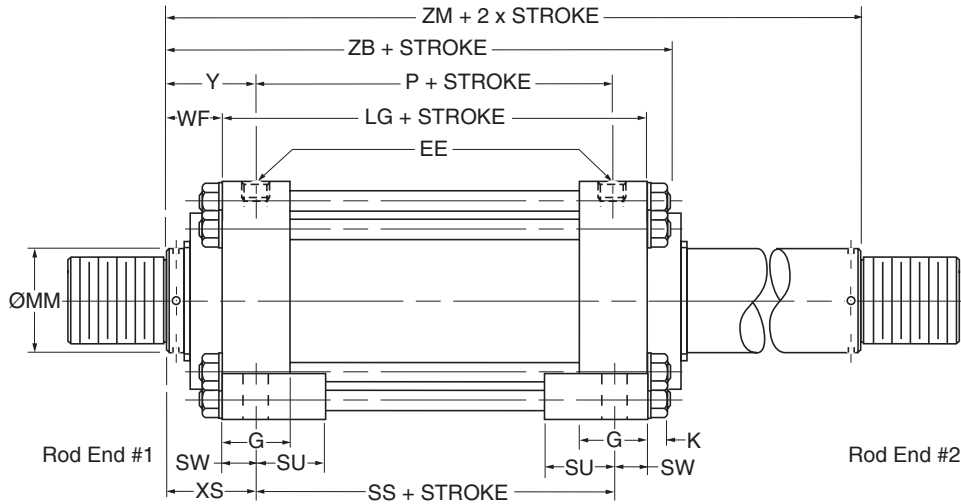

Mounting Styles for Single Rod Models	Mounting Styles for Corresponding Double Rod Models <sup>1</sup>	Dimension Shown on This Page Supplement Dimensions on Pages Listed Below
TB	KTB	50
TD	KTD	50
C	KC	51
JJ	KJJ	52
JB	KJB	53
D	KD	57
DD	KDD <sup>2</sup>	59

<sup>1</sup>If only one end of these Double Rod Cylinders is to be cushioned, be sure to specify clearly which end this will be.

<sup>2</sup>Specify XI dimension from rod end #1.

Bore Ø	Rod Code	Rod Ø	Add 2X Stroke
			ZM
10.00	1	4.500	18.00
	2	7.000	19.12
	3	5.000	18.50
	4	5.500	18.50
12.00	1	5.500	20.88
	2	8.000	22.50
	3	7.000	21.50
14.00	1	7.000	22.63
	2	10.000	24.63
	3	8.000	23.63
16.00	1	8.000	26.13
	3	9.000	26.63
	4	10.000	27.13
18.00	1	9.000	29.63
	3	10.000	30.13
20.00	1	10.000	32.63

**How to Use Double Rod Cylinder Dimension Drawings**

To obtain dimensioning information on a double rod cylinder, first select the desired mounting style and refer to the corresponding single rod cylinder model shown on the preceding pages. (See table above.) After you have determined all necessary dimensions from that drawing, turn back to this page and supplement those dimensions with additional ones from the drawing above and table at right. These added dimensions differ from, or are in addition to, those shown on the preceding pages and

provide the additional information needed to completely dimension a double rod cylinder model.

On a double rod cylinder where the two rod ends are different, be sure to clearly state which rod end is to be assembled at which end. Port position 1 is standard. If other than standard, specify pos. 2, 3 or 4 when viewed from rod end #1 only.

**⚠ PROP 65 WARNING** WARNING: This product can expose you to chemicals including **Lead and Lead Compounds** which are known to the State of California to cause cancer and birth defects or other reproductive harm. For more information go to [www.P65Warnings.ca.gov](http://www.P65Warnings.ca.gov)

PH Series  
 10.00" - 20.00"



**Section D****Cylinder Accessories and Replacement Parts**

Mounting Accessories	68-71
Style SB Spherical Bearing Mounting Accessories	72
Style SE Spherical Bearing Mounting Accessories	73
Linear Alignment Couplers	74
Split Couplers / Weld Plates / Dual Axis Knuckles	75
PH Parts Identification	76, 82
PH Rod Gland and Rod Seal Kits (Including Crown Wiper Kits), Gland Retainer Screw Torque, Piston Seal and Body Seal Kits	77-81, 83

**⚠ PROP 65 WARNING** WARNING: This product can expose you to chemicals including **Lead and Lead Compounds** which are known to the State of California to cause cancer and birth defects or other reproductive harm. For more information go to [www.P65Warnings.ca.gov](http://www.P65Warnings.ca.gov)

**Cylinder Accessories**

Schrader Bellows offers a complete range of cylinder accessories to assure flexibility and versatility in present or future cylinder applications.

**Rod End Accessories**

Accessories offered for the rod end of the cylinder include: Rod Clevis, Eye Bracket, Knuckle, Clevis Bracket and Pivot Pin. To select the proper part number for any desired accessory, refer to Chart A below and look opposite the thread size of the rod end as indicated in the first column. The Pivot Pins, Eye Brackets and Clevis Brackets are listed opposite the thread size which their mating Knuckles or Clevises fit.



**Accessory Load Capacity**

The various accessories on this and the following pages have been load rated for your convenience. The load capacity shown in lbs. is the recommended maximum load for that accessory based on a 4:1 design factor in tension. (Pivot Pin is rated in shear.) Before specifying,

compare the actual load or the tension (pull) force at maximum operating pressure of the cylinder with the load capacity of the accessory you plan to use. If load or pull force of cylinder exceeds load capacity of accessory, consult factory.

**Chart A**

Thread Size	Pin Ø	Rod Clevis		Mounting Plate or Eye Bracket		Pivot Pin	
		Part Number	Load Capacity (lb)	Forged Steel or Cast Ductile Iron		Part Number	Shear Capacity (lb)
				Part Number	Load Capacity (lb)		
5/16-24	0.312	0512210000 <sup>1</sup>	2,600	0959810031	1,850	-	-
7/16-20	0.500	0509400000	4,250	0959810050 <sup>2</sup>	4,620	0683680000	8,600
1/2-20	0.500	0509410000	4,900	0959810050 <sup>2</sup>	4,620	0683680000	8,600
3/4-16	0.750	0509420000	11,200	0959810075 <sup>2</sup>	12,370	0683690000	19,300
3/4-16	0.750	1332840000	11,200	0959810075 <sup>2</sup>	12,370	0683690000	19,300
7/8-14	1.000	0509430000	18,800	0959810100 <sup>2</sup>	20,450	0683700000	34,300
1-14	1.000	0509440000	19,500	0959810100 <sup>2</sup>	20,450	0683700000	34,300
1-14	1.000	1332850000	19,500	0959810100 <sup>2</sup>	20,450	0683700000	34,300
1 1/4-12	1.375	0509450000	33,500	0959810138	33,500	0683710000	65,000
1 1/4-12	1.375	1332860000	33,500	0959810138	33,500	0683710000	65,000
1 1/2-12	1.750	0509460000	45,600	0959810175	49,480	0683720000	105,200
1 3/4-12	2.000	0509470000	65,600	0959810200 <sup>2</sup>	70,100	0683730000	137,400
1 7/8-12	2.000	0509480000	65,600	0959810200 <sup>2</sup>	70,100	0683730000	137,400
2 1/4-12	2.500	0509490000	98,200	0959810250 <sup>2</sup>	98,200	0683740000	214,700
2 1/2-12	3.000	0509500000	98,200	0959810300 <sup>2</sup>	121,940	0683750000	309,200
2 3/4-12	3.000	0509510000	98,200	0959810300 <sup>2</sup>	121,940	0683750000	309,200
3 1/4-12	3.500	0509520000	156,700	0959810350	187,910	0735450000	420,900
3 1/2-12	4.000	0509530000	193,200	0959810400	268,000	0735470000	565,800
4-12	4.000	0509540000	221,200	0959810400	268,000	0735470000	565,800

<sup>1</sup> Includes pivot pin.

<sup>2</sup> Cylinder accessory dimensions conform to ANSI/NFPA/T3.6.8 R3-2010.

**Mounting Plates**

Mounting Plates for Style BB (clevis mounted) cylinders are offered. To select proper part number for your application, refer to Chart B at right.

**Chart B**

Series 2H, 2HD, 2HB		Series 3H, 3HD	
Mounting Plate Part Number	Bore Ø	Mounting Plate Part Number	Bore Ø
0959810050	1.50	0959810250	7.00
0959810075	2.00, 2.50	0959810300	8.00
0959810100	3.25	0959810350	10.00
0959810138	4.00	0959810400	12.00
0959810175	5.00		
0959810200	6.00		

**⚠ PROP 65 WARNING** WARNING: This product can expose you to chemicals including **Lead and Lead Compounds** which are known to the State of California to cause cancer and birth defects or other reproductive harm. For more information go to [www.P65Warnings.ca.gov](http://www.P65Warnings.ca.gov)



**Rod Clevis Dimensions**

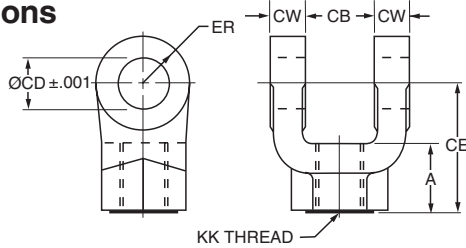

**Pivot Pin Dimensions**

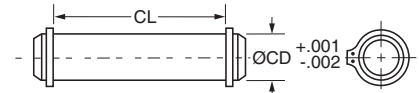

Part Number <sup>1</sup>	Pin Ø	A	CB	CD Ø	CE	CW	ER	KK Thread
0512210000 <sup>2</sup>	0.310	0.81	0.34	0.314	2.25	0.20	0.30	5/16-24
0509400000	0.500	0.75	0.77	0.503	1.50	0.49	0.50	7/16-20
0509410000	0.500	0.75	0.77	0.503	1.50	0.49	0.50	1/2-20
0509420000	0.750	1.13	1.27	0.753	2.13	0.62	0.75	3/4-16
1332840000	0.750	1.13	1.27	0.753	2.38	0.62	0.75	3/4-16
0509430000	1.000	1.63	1.52	1.003	2.94	0.74	1.00	7/8-14
0509440000	1.000	1.63	1.52	1.003	2.94	0.74	1.00	1-14
1332850000	1.000	1.63	1.52	1.003	3.13	0.74	1.00	1-14
0509450000	1.375	1.88	2.04	1.378	3.75	0.99	1.38	1 1/4-12
1332860000	1.375	2.00	2.04	1.378	4.13	0.99	1.38	1 1/4-12
0509460000	1.750	2.25	2.54	1.753	4.50	1.24	1.75	1 1/2-12
0509470000	2.000	3.00	2.54	2.003	5.50	1.24	2.00	1 3/4-12
0509480000	2.000	3.00	2.54	2.003	5.50	1.24	2.00	1 7/8-12
0509490000	2.500	3.50	3.04	2.503	6.50	1.49	2.50	2 1/4-12
0509500000	3.000	3.50	3.04	3.003	6.75	1.49	2.75	2 1/2-12
0509510000	3.000	3.50	3.04	3.003	6.75	1.49	2.75	2 3/4-12
0509520000	3.500	3.50 <sup>3</sup>	4.04	3.503	7.75	1.98	3.50	3 1/4-12
0509530000	4.000	4.00 <sup>3</sup>	4.54	4.003	8.81	2.23	4.00	3 1/2-12
0509540000	4.000	4.00 <sup>3</sup>	4.54	4.003	8.81	2.23	4.00	4-12

Part Number	CD Ø	CL
0683680000	0.500	1.88
0683690000	0.750	2.63
0683700000	1.000	3.13
0683710000	1.375	4.19
0683720000	1.750	5.19
0683730000	2.000	5.19
0683740000	2.500	6.19
0683750000	3.000	6.25
0735450000	3.500	8.25
0735470000 <sup>4</sup>	4.000	9.00

<sup>4</sup> This size supplied with cotter pins.

1. Pivot Pins are furnished with Clevis Mounted Cylinders as standard.
2. Pivot Pins are furnished with (2) Retainer Rings.
3. Pivot Pins must be ordered as a separate item if to be used with Knuckles, Rod Clevises, or Clevis Brackets.

<sup>1</sup> Rod Clevises with pin diameters 0.312 thru 1.375 are forged steel. Rod Clevises with 1.750 pin diameter and larger are cast ductile iron.

<sup>2</sup> Includes Pivot Pin

<sup>3</sup> Consult appropriate cylinder rod end dimensions for compatibility.

**Forged Steel or Cast Ductile Iron Mounting Plate or Eye Bracket Dimensions<sup>5</sup>**

Note: Cast ductile iron eye brackets must not be welded in place.

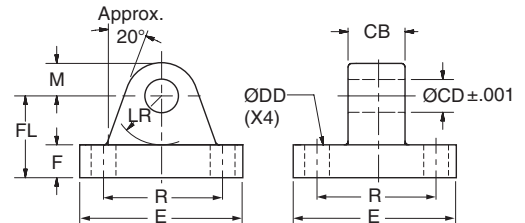

Cast or Forged <sup>6</sup> Part Number	Pin Ø	CB	CD Ø	DD Ø	E (As Cast)	F	FL	LR	M (As Cast)	R
0959810031	0.312	0.31	0.314	0.27	2.25	0.38	1.00	0.59	0.38	1.75
0959810050	0.500	0.75	0.503	0.41	2.50	0.38	1.13	0.69	0.50	1.63
0959810075	0.750	1.25	0.753	0.53	3.50	0.63	1.88	1.13	0.75	2.55
0959810100	1.000	1.50	1.003	0.66	4.50	0.88	2.38	1.37	1.00	3.25
0959810138	1.375	2.00	1.378	0.66	5.00	1.00 <sup>7</sup>	3.00	1.88	1.38	3.82
0959810175	1.750	2.50	1.753	0.91	6.50	1.25 <sup>7</sup>	3.38	2.13	1.75	4.95
0959810200	2.000	2.50	2.003	1.06	7.50	1.50	4.00	2.38	2.00	5.73
0959810250	2.500	3.00	2.503	1.19	8.50	1.75	4.75	2.88	2.50	6.58
0959810300	3.000	3.00	3.003	1.31	9.50	2.00	5.25	3.13	3.00	7.50
0959810350	3.500	4.00	3.503	1.81	12.63	2.50 <sup>8</sup>	6.50 <sup>8</sup>	3.88	3.50	9.62
0959810400	4.000	4.50	4.003	2.06	14.88	3.00 <sup>8</sup>	7.50 <sup>8</sup>	4.38	4.06	11.45

<sup>5</sup> When used to mate with the Rod Clevis, select by pin diameter in the table above.

<sup>6</sup> Eye Brackets with pin diameters 0.500 thru 1.375 are forged steel. Eye Brackets with 0.312 and 1.750 pin diameter and larger are cast ductile iron.

<sup>7</sup> These dimensions vary from NFPA standard. F is increased by 0.13. Sufficient LR clearance remains for full swing arc with Schrader Bellows cap clevis cylinders and rod clevises.

<sup>8</sup> Mounting base thickness dimension F is increased on these sizes to provide greater load capacity than the former fabricated steel design. Cast ductile iron dimensions F and FL are 0.81 larger for 3.500 pin diameter and 1.06 larger for 4.000 pin diameter.

**⚠ PROP 65 WARNING** WARNING: This product can expose you to chemicals including **Lead and Lead Compounds** which are known to the State of California to cause cancer and birth defects or other reproductive harm. For more information go to [www.P65Warnings.ca.gov](http://www.P65Warnings.ca.gov)

## Rod End Accessories

Accessories offered for the rod end of the cylinder include Rod Clevis, Eye Bracket, Knuckle, Clevis Bracket, and Pivot Pin. To select the proper part number for any desired accessory, refer to the table below or on the opposite page and look in the row to the right of the rod thread in the first column. For economical accessory selection, it is recommended that rod end style 4 be specified on your cylinder order.

## Accessory Load Capacity

The various accessories have been load rated for your convenience. The Load Capacity in pounds is the recommended maximum load for that accessory based on a 4:1 design factor in tension. (Pivot Pin is rated in shear.) Before specifying, compare the actual load or the tension (pull) force at the maximum operating pressure of the cylinder with the load capacity of the accessory you plan to use. If load or pull force of cylinder exceeds load capacity of accessory, consult factory.

Thread Size	Pin Ø	Knuckle		Clevis Bracket				Pivot Pin	
		Part Number	Load Capacity (lb)	Forged Steel or Cast Ductile Iron		Fabricated Steel		Part Number	Shear Capacity (lb)
				Part Number	Load Capacity (lb)	Part Number	Load Capacity (lb)		
5/16-24	0.438	0740750000	3,300	0960160044	2,830	0740760000	3,600	0740780000	6,600
7/16-20	0.500	0690890000	5,000	0960160050	7,740	0692050000	7,300	0683680000	8,600
1/2-20	0.500	0690900000	5,700	0960160050	7,740	0692050000	7,300	0683680000	8,600
3/4-16	0.750	0690910000	12,100	0960160075	13,600	0692060000	10,880	0683690000	19,300
7/8-14	1.000	0690920000	13,000	0960160100	23,000	0692070000	15,180	0683700000	34,300
1-14	1.000	0690930000	21,700	0960160100	23,000	0692070000	15,180	0683700000	34,300
1 1/4-12	1.375	0690940000	33,500	0960160138	39,500	0692080000	23,560	0683710000	65,000
1 1/2-12	1.750	0690950000	45,000	0960160175	49,480	0692090000	21,520	0683720000	105,200
1 3/4-12	2.000	0690960000	53,500	0960160200	72,400	0692100000	26,000	0692150000	137,400
1 7/8-12	2.000	0962160000	75,000	0960160200	72,400	0692100000	26,000	0692150000	137,400
2 1/4-12	2.500	0962170000	98,700	0960160250	98,700	0692110000	28,710	0683740000	214,700
2 1/2-12	3.000	0962180000	110,000	0960160300	123,300	0692120000	28,190	0683750000	309,200
2 3/4-12	3.000	0962190000	123,300	N/A	N/A	0692130000	31,390	0692160000	309,200
3 1/4-12	3.500	0962200000	161,300	0960160350	200,400	0735420000	80,250	0735450000	420,900
3 1/2-12	3.500	0962210000	217,300	0960160350	200,400	0735420000	80,250	0735450000	420,900
4-12	4.000	0962220000	273,800	0960160400	292,100	0735430000	98,420	0821810000	565,800
N/A	4.000	N/A	N/A	N/A	N/A	N/A	N/A	0735470000 <sup>1</sup>	565,800

<sup>1</sup> This size supplied with cotter pins.

## Forged Steel or Cast Ductile Iron Clevis Bracket Dimensions

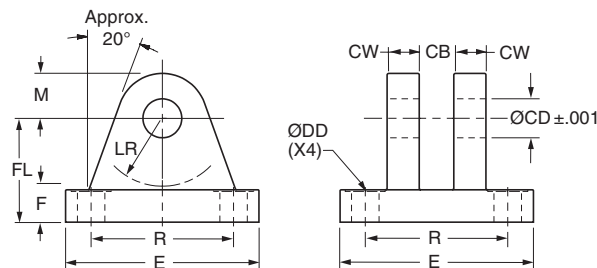

**Note: Cast ductile iron clevis brackets must not be welded in place.**

Cast or Forged <sup>2</sup> Part Number	Pin Ø	CB	CD Ø	CW	DD Ø	E (As Cast)	F	FL	LR	M (As Cast)	R
0960160044	0.438	0.46	0.440	0.37	0.27	2.25	0.38	1.00	0.56	0.44	1.75
0960160050	0.500	0.78	0.503	0.50	0.41	2.50	0.38	1.13	0.63	0.56	1.63
0960160075	0.750	1.28	0.753	0.63	0.53	3.50	0.63	1.88	1.06	0.75	2.56
0960160100	1.000	1.53	1.003	0.75	0.66	4.50	0.75	2.25	1.25	1.00	3.25
0960160138	1.375	2.03	1.378	1.00	0.66	5.00	0.88	3.00	1.94	1.38	3.81
0960160175	1.750	2.53	1.753	1.25	0.91	6.50	0.94	3.13	2.00	1.75	4.94
0960160200	2.000	2.53	2.003	1.25	1.06	7.50	1.38	3.75	2.25	2.00	5.75
0960160250	2.500	3.03	2.503	1.50	1.19	8.50	1.50	4.50	2.81	2.50	6.59
0960160300	3.000	3.03	3.003	1.50	1.31	9.50	1.88	5.38	3.31	3.00	7.50
0960160350	3.500	4.03	3.503	2.00	1.81	12.63	2.31	6.38	3.88	3.50	9.62
0960160400	4.000	4.53	4.003	2.25	2.06	14.88	2.88	7.50	4.50	4.00	11.50

<sup>2</sup> Clevis Brackets with pin diameters 0.500 thru 1.375 are forged steel. Clevis Brackets with 0.438 and 1.750 pin diameter and larger are cast ductile iron.

**⚠ PROP 65 WARNING** WARNING: This product can expose you to chemicals including **Lead and Lead Compounds** which are known to the State of California to cause cancer and birth defects or other reproductive harm. For more information go to [www.P65Warnings.ca.gov](http://www.P65Warnings.ca.gov)

**Knuckle Dimensions**

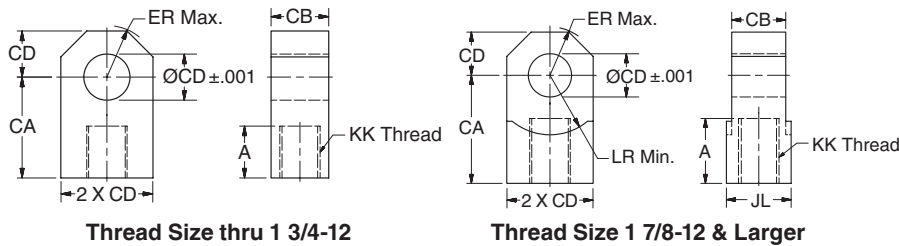

**Pivot Pin Dimensions**

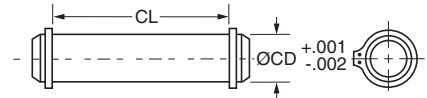

Part Number	Pin Ø	A	CA	CB	CD Ø	ER	JL	LR min	KK Thread
0740750000	0.438	0.75	1.50	0.43	0.440	0.53	-	-	5/16-24
0690890000	0.500	0.75	1.50	0.75	0.503	0.59	-	-	7/16-20
0690900000	0.500	0.75	1.50	0.75	0.503	0.59	-	-	1/2-20
0690910000	0.750	1.13	2.06	1.25	0.753	0.87	-	-	3/4-16
0690920000	1.000	1.13	2.38	1.50	1.003	1.15	-	-	7/8-14
0690930000	1.000	1.63	2.81	1.50	1.003	1.15	-	-	1-14
0690940000	1.375	2.00	3.44	2.00	1.378	1.55	-	-	1 1/4-12
0690950000	1.750	2.25	4.00	2.50	1.753	1.96	-	-	1 1/2-12
0690960000	2.000	2.25	4.38	2.50	2.003	2.24	-	-	1 3/4-12
0962160000	2.000	3.00	5.00	2.50	2.003	2.24	3.00	2.77	1 7/8-12
0962170000	2.500	3.50	5.81	3.00	2.503	2.76	3.50	3.09	2 1/4-12
0962180000	3.000	3.50	6.13	3.00	3.003	3.30	4.00	3.58	2 1/2-12
0962190000	3.000	3.63	6.50	3.50	3.003	3.30	4.00	3.58	2 3/4-12
0962200000	3.500	4.50	7.63	4.00	3.503	3.87	6.00	4.18	3 1/4-12
0962210000	3.500	5.00	7.63	4.00	3.503	3.87	6.00	4.18	3 1/2-12
0962220000	4.000	5.50	9.13	4.50	4.003	4.43	6.00	4.80	4-12

Part Number	CD Ø	CL
0740780000	0.438	1.31
0683680000	0.500	1.88
0683690000	0.750	2.63
0683700000	1.000	3.13
0683710000	1.375	4.19
0683720000	1.750	5.19
0692150000	2.000	5.69
0683740000	2.500	6.19
0683750000	3.000	6.25
0692160000	3.000	6.75
0735450000	3.500	8.25
0821810000	4.000	8.69
0735470000 <sup>1</sup>	4.000	9.00

<sup>1</sup>This size supplied with cotter pins.

1. Pivot Pins are furnished with Clevis Mounted Cylinders as standard.
2. Pivot Pins are furnished with (2) Retainer Rings.
3. Pivot Pins must be ordered as a separate item if to be used with Knuckles, Rod Clevises, or Clevis Brackets.

**Fabricated Steel Clevis Bracket Dimensions**

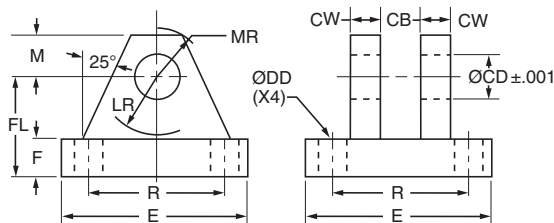

Fabricated Steel Part Number	Pin <sup>2</sup> Ø	CB	CD Ø	CW	DD Ø	E	F	FL	LR	M	MR	R
0692050000	0.500	0.80	0.503	0.50	0.41	3.50	0.50	1.50	0.75	0.50	0.63	2.55
0692060000	0.750	1.30	0.753	0.63	0.53	5.00	0.63	1.88	1.19	0.75	0.91	3.82
0692070000	1.000	1.59	1.003	0.75	0.66	6.50	0.75	2.25	1.50	1.00	1.25	4.95
0692080000	1.375	2.09	1.378	1.00	0.66	7.50	0.88	3.00	2.00	1.38	1.66	5.73
0692090000	1.750	2.59	1.753	1.25	0.91	9.50	0.88	3.63	2.75	1.75	2.22	7.50
0692100000	2.000	2.59	2.003	1.50	1.06	12.75	1.00	4.25	3.19	2.25	2.78	9.40
0692110000	2.500	3.09	2.503	1.50	1.19	12.75	1.00	4.50	3.50	2.50	3.13	9.40
0692120000	3.000	3.09	3.003	1.50	1.31	12.75	1.00	6.00	4.25	3.00	3.59	9.40
0692130000	3.000	3.59	3.003	1.50	1.31	12.75	1.00	6.00	4.25	3.00	3.59	9.40
0735420000	3.500	4.09	3.503	2.00	1.81	15.50	1.69	6.69	5.00	3.50	4.13	12.00
0735430000	4.000	4.59	4.003	2.00	2.06	17.50	1.94	7.69	5.75	4.00	4.88	13.75

<sup>2</sup> Clevis Bracket for 0.438 diameter pin is only available in cast ductile iron construction. See part number 0960160044 on previous page.

**⚠ PROP 65 WARNING** WARNING: This product can expose you to chemicals including **Lead and Lead Compounds** which are known to the State of California to cause cancer and birth defects or other reproductive harm. For more information go to [www.P65Warnings.ca.gov](http://www.P65Warnings.ca.gov)

Schrader Bellows offers a complete range of Cylinder Accessories to assure you of the greatest versatility in present or future cylinder applications. Accessories offered for spherical bearing mount cylinders include

the Rod Eye, Pivot Pin and Clevis Bracket. To select the proper part number for any desired accessory refer to the tables below.

**Spherical Rod Eye Dimensions**

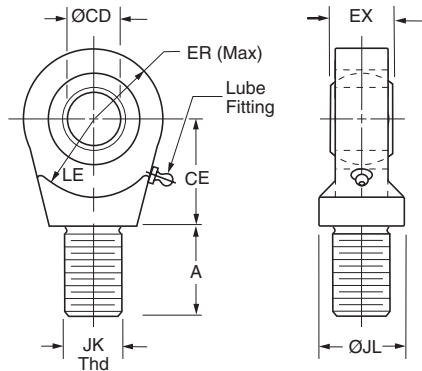

Bore Ø	Part Number	CD Ø	A	CE	EX	ER	LE	JK Thread	JL Ø	Load Capacity (lb)
1.50	0961000050	.5000 <sup>-0005</sup>	0.72	0.86	0.44	0.80	0.78	7/16-20	0.88	2,644
2.00 & 2.50	0961000075	.7500 <sup>-0005</sup>	1.02	1.25	0.66	1.14	1.06	3/4-16	1.31	9,441
3.25	0961000100	1.0000 <sup>-0005</sup>	1.52	1.88	0.88	1.34	1.45	1-14	1.50	16,860
4.00	0961000138	1.3750 <sup>-0005</sup>	2.02	2.13	1.19	1.67	1.91	1 1/4-12	2.00	28,562
5.00	0961000175	1.7500 <sup>-0005</sup>	2.14	2.50	1.53	2.05	2.16	1 1/2-12	2.00	43,005
6.00	0961000200	2.0000 <sup>-0005</sup>	2.89	2.75	1.75	2.60	2.50	1 7/8-12	2.75	70,193

Order to fit Piston Rod Thread Size.

**Pivot Pin Dimensions**

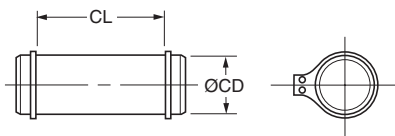

Bore Ø	Part Number	CD Ø	CL	Shear Capacity (lb)
1.50	0839620000	.4997 <sup>-0004</sup>	1.56	8,600
2.00 & 2.50	0839630000	.7497 <sup>-0005</sup>	2.03	19,300
3.25	0839640000	.9997 <sup>-0005</sup>	2.50	34,300
4.00	0839650000	1.3746 <sup>-0006</sup>	3.31	65,000
5.00	0839660000	1.7496 <sup>-0006</sup>	4.22	105,200
6.00	0839670000	1.9996 <sup>-0007</sup>	4.94	137,400

Pivot Pins are furnished with (2) Retainer Rings.

**Clevis Bracket Dimensions**

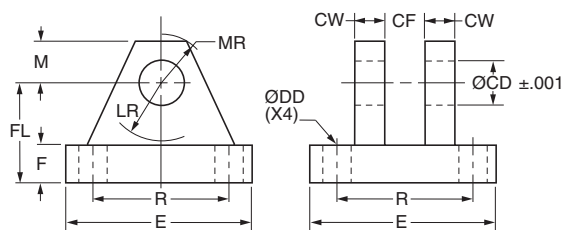

**Fabricated Steel**

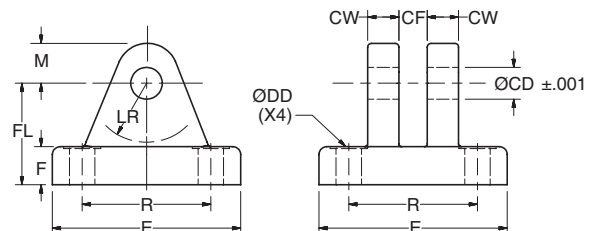

**Cast Ductile Iron**

Order to fit Cylinder Cap or Rod Eye.

Bore Ø	Pin Ø	Cast Ductile Iron Part Number	Fabricated Steel Part Number	CD Ø	CF	CW	DD Ø	E	F	FL	LR	M	MR	R	Load Capacity (lb)
1.50	0.500	0959450000	0839470000	0.503	0.45	0.50	0.41	3.00	0.50	1.50	0.94	0.50	0.63	2.05	5,770
2.00 & 2.50	0.750	0959300000	0839480000	0.753	0.67	0.63	0.53	3.75	0.63	2.00	1.38	0.88	1.00	2.76	9,450
3.25	1.000	0959310000	0839490000	1.003	0.89	0.75	0.53	5.50	0.75	2.50	1.69	1.00	1.19	4.10	14,300
4.00	1.375	0959320000	0839500000	1.378	1.20	1.00	0.66	6.50	0.88	3.50	2.44	1.38	1.63	4.95	20,322
5.00	1.750	0959330000	0839510000	1.753	1.55	1.25	0.91	8.50	1.25	4.50	2.88	1.75	2.06	6.58	37,800
6.00	2.000	0959340000	0839520000	2.003	1.77	1.50	0.91	10.63	1.50	5.00	3.00	2.00	2.38	7.92	50,375

**PROP 65 WARNING** WARNING: This product can expose you to chemicals including **Lead and Lead Compounds** which are known to the State of California to cause cancer and birth defects or other reproductive harm. For more information go to [www.P65Warnings.ca.gov](http://www.P65Warnings.ca.gov)



Schrader Bellows offers a complete range of Cylinder Accessories to assure you of the greatest versatility in present or future cylinder applications. Accessories offered for spherical bearing mount cylinders include

the Rod Eye, Pivot Pin and Clevis Bracket. To select the proper part number for any desired accessory refer to the tables below.

**Spherical Rod Eye Dimensions**

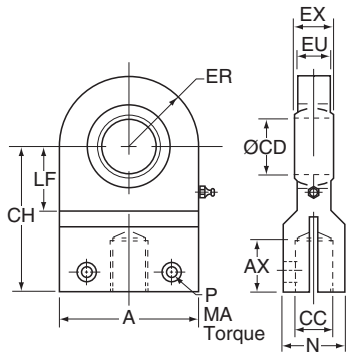

Bore Ø	Part Number	A	AX (min.)	CH	CD Ø	ER	EU	EX	CC Thread	LF	MA (lb-ft)	N	P (SHCS)	Load Cap. (lb)
1.50	0978200075	1.75	0.75	1.75	0.7500 <sup>-0.0004</sup>	0.88	0.56	0.656	1/2-20	0.94	11	0.88	1/4-28	5,301
2.00	0978200100	2.50	1.13	2.50	1.0000 <sup>-0.0004</sup>	1.25	0.75	0.875	7/8-14	1.19	40	1.25	3/8-24	9,425
2.50	0978200125	3.00	1.13	2.75	1.2500 <sup>-0.0005</sup>	1.50	0.94	1.093	7/8-14	1.44	40	1.38	3/8-24	14,726
3.25	0978200150	4.00	1.63	3.75	1.5000 <sup>-0.0005</sup>	2.00	1.13	1.312	1 1/4-12	1.75	100	2.00	1/2-20	24,887
4.00	0978200200	4.50	2.00	4.50	2.0000 <sup>-0.0005</sup>	2.25	1.50	1.750	1 1/2-12	2.25	185	2.50	5/8-18	37,699
5.00	0978200250	6.00	2.25	5.25	2.5000 <sup>-0.0006</sup>	3.00	1.88	2.187	1 3/4-12	2.81	325	2.75	3/4-16	58,905
6.00	0978200300	7.00	3.00	6.75	3.0000 <sup>-0.0006</sup>	3.50	2.25	2.625	2 1/4-12	3.31	525	3.50	7/8-14	84,823
7.00	0978200350	8.00	3.50	8.00	3.5000 <sup>-0.0008</sup>	4.00	2.63	3.062	2 3/4-12	3.94	800	4.50	1-14	115,454
8.00	0978200400	9.00	3.50	8.50	4.0000 <sup>-0.0008</sup>	4.50	3.00	3.500	3 1/4-12	4.50	800	5.00	1-14	150,796

Order to fit Piston Rod Thread Size.

**Pivot Pin Dimensions**

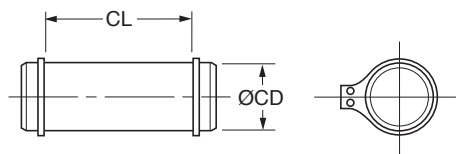

Pivot Pins are furnished with (2) Retainer Rings.

Bore Ø	Pin Ø	Part Number	CD Ø	CL	Shear Capacity (lb)
1.50	0.750	0977260075	0.7497 <sup>-0.0005</sup>	1.78	19,300
2.00	1.000	0977260100	0.9997 <sup>-0.0005</sup>	2.00	34,300
2.50	1.250	0977260125	1.2496 <sup>-0.0006</sup>	2.50	53,600
3.25	1.500	0977260150	1.4996 <sup>-0.0006</sup>	3.00	77,300
4.00	2.000	0977260200	1.9996 <sup>-0.0007</sup>	3.94	137,400
5.00	2.500	0977260250	2.4996 <sup>-0.0007</sup>	4.88	214,700
6.00	3.000	0977260300	2.9996 <sup>-0.0007</sup>	5.31	309,100
7.00	3.500	0977260350	3.4995 <sup>-0.0009</sup>	6.25	420,700
8.00	4.000	0977260400	3.9995 <sup>-0.0009</sup>	6.69	549,400

**Forged Steel or Cast Ductile Iron Clevis Bracket Dimensions<sup>1</sup>**

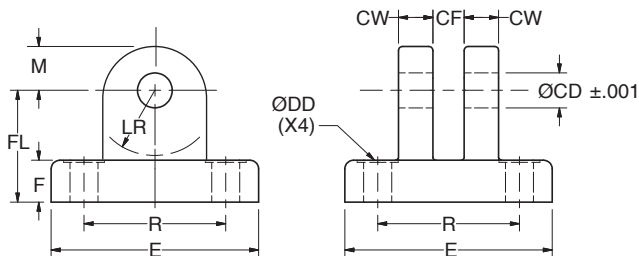

Order to fit Cylinder Cap or Rod Eye.

Bore Ø	Pin Ø	Part Number	CD Ø ±0.001	CF	CW	DD Ø	E	F	FL	LR	M	R	Load Capacity (lb)
1.50	0.750	0977270075	0.753	0.67	0.50	0.41	2.75	0.38	1.63	1.06	0.63	2.00	5,301
2.00	1.000	0977270100	1.003	0.89	0.50	0.47	3.25	0.50	2.00	1.31	0.81	2.44	9,425
2.50	1.250	0977270125	1.253	1.11	0.63	0.53	4.00	0.75	2.50	1.56	1.00	3.00	14,726
3.25	1.500	0977270150	1.503	1.33	0.75	0.66	5.00	0.75	3.00	2.06	1.25	3.75	24,887
4.00	2.000	0977270200	2.003	1.77	1.00	0.66	5.50	1.00	3.50	2.31	1.63	4.31	37,699
5.00	2.500	0977270250	2.503	2.20	1.25	0.91	7.00	1.25	4.50	3.06	2.00	5.44	58,905
6.00	3.000	0977270300	3.003	2.64	1.25	1.06	8.25	1.50	5.25	3.56	2.50	6.38	84,823
7.00	3.500	0977270350	3.503	3.08	1.50	1.19	9.25	1.75	6.00	4.06	3.00	7.38	115,454
8.00	4.000	0977270400	4.003	3.52	1.50	1.31	10.50	2.00	6.75	4.56	3.50	8.50	150,796

<sup>1</sup> Clevis Brackets with pin diameters 0.750 thru 2.000 are forged steel. Clevis Brackets with 2.500 pin diameter and larger are cast ductile iron.

**⚠ PROP 65 WARNING** WARNING: This product can expose you to chemicals including **Lead and Lead Compounds** which are known to the State of California to cause cancer and birth defects or other reproductive harm. For more information go to [www.P65Warnings.ca.gov](http://www.P65Warnings.ca.gov)

# Linear Alignment Couplers are available in 19 standard thread sizes...



## Cost Saving Features and Benefits Include

- Maximum reliability for trouble-free operation, long life and lower operating costs
- Increased cylinder life by reducing wear on Piston and Rod bearings
- Simplifying Cylinder installation and reducing assembly costs
- Increase Rod Bearing and Rod Seal life for lower maintenance costs

## Alignment Coupler

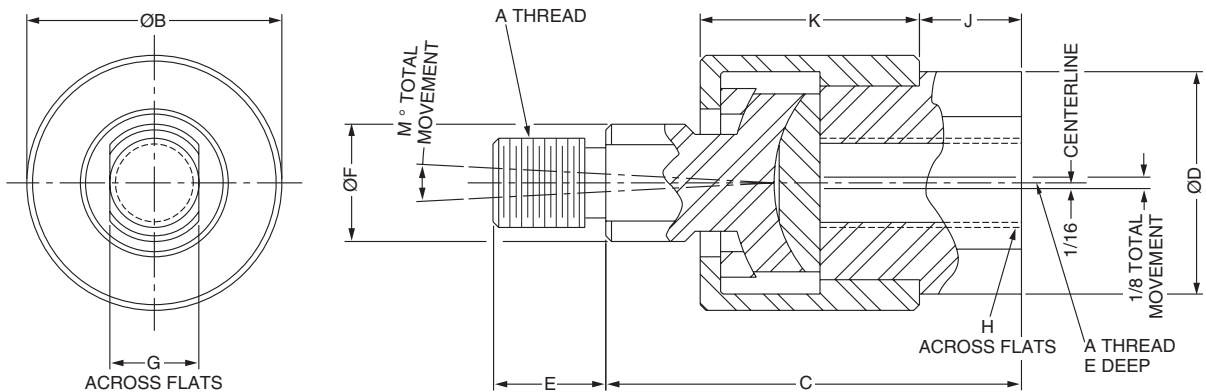

### Part Numbers and Dimensions

Part Number	A	B Ø	C	D Ø	E	F Ø	G	H	J	K	M	Max. Pull Load (lb)	Max. Approx. Weight (lb)
1347570031	5/16-24	1.13	1.75	0.94	0.50	0.50	0.38	0.75	0.38	0.94	6°	1,200	.35
1347570038	3/8-24	1.13	1.75	0.94	0.50	0.50	0.38	0.75	0.38	0.94	6°	2,425	.35
1347570044	7/16-20	1.38	2.00	1.13	0.75	0.63	0.50	0.88	0.38	1.09	6°	3,250	.55
1347570050	1/2-20	1.38	2.00	1.13	0.75	0.63	0.50	0.88	0.38	1.09	6°	4,450	.55
1347570063	5/8-18	1.38	2.00	1.13	0.75	0.63	0.50	0.88	0.38	1.09	6°	6,800	.55
1347570075	3/4-16	2.00	2.31	1.63	1.13	0.94	0.75	1.31	0.44	1.28	6°	9,050	1.4
1347570088	7/8-14	2.00	2.31	1.63	1.13	0.94	0.75	1.31	0.44	1.28	6°	14,450	1.4
1347570100	1-14	3.13	3.00	2.38	1.63	1.44	1.25	1.88	0.75	1.78	6°	19,425	4.8
1347570125	1 1/4-12	3.13	3.00	2.38	1.63	1.44	1.25	1.88	0.75	1.78	6°	30,500	4.8
1337390125	1 1/4-12	3.50	4.00	2.00	2.00	1.50	1.25	1.69	0.75	2.50	10°	30,500	6.9
1337390150	1 1/2-12	4.00	4.38	2.25	2.25	1.75	1.50	1.94	0.88	2.75	10°	45,750	9.8
1337390175	1 3/4-12	4.00	4.38	2.25	2.25	1.75	1.50	1.94	0.88	2.75	10°	58,350	9.8
1337390188	1 7/8-12	5.00	5.63	3.00	3.00	2.25	2.00	2.63	1.38	3.38	10°	67,550	19.8
1337390200	2-12	5.00	5.63	3.00	3.00	2.25	2.00	2.63	1.38	3.38	10°	77,450	19.8
1337390225	2 1/4-12	6.75	6.38	3.25	3.50	2.75	2.38	2.88	1.63	3.75	10°	99,250	35.3
1337390250	2 1/2-12	7.00	6.50	4.00	3.50	3.25	2.88	3.38	1.63	3.88	10°	123,750	45.3
1337390275	2 3/4-12	7.00	6.50	4.00	3.50	3.25	2.88	3.38	1.63	3.88	10°	150,950	45.3
1337390300	3-12	7.00	6.50	4.00	3.50	3.25	2.88	3.38	1.63	3.88	10°	180,850	45.3
1337390325	3 1/4-12	9.25	8.50	5.25	4.50	4.00	3.38	4.50	2.00	5.50	10°	213,450	-
1337390425	4 1/4-12	12.88	11.25	7.75	4.50	5.50	4.88	7.00	1.50	8.75	10°	370,850	-

**How to Order Linear Alignment Couplers** — When ordering a cylinder with a threaded male rod end, specify the coupler of equal thread size by part number as listed in Table 1, i.e.; Piston Rod “KK” or “CC” dimension is 3/4" - 16", specify coupler part number 1347570075.

**⚠ PROP 65 WARNING** WARNING: This product can expose you to chemicals including **Lead and Lead Compounds** which are known to the State of California to cause cancer and birth defects or other reproductive harm. For more information go to [www.P65Warnings.ca.gov](http://www.P65Warnings.ca.gov)



### Split Couplers and Weld Plates for Schrader Bellows "Style 55" Piston Rod End

Rod Ø	A Ø	B Ø	C	D	E Ø	F	Bolt Size	Bolt Circle	Split Coupler Part Number	Weld Plate Part Number
0.625	1.50	2.00	0.50	0.56	0.25	4	#10-24 x .94 LG	1.125	1472340062	1481740062
1.000	2.00	2.50	0.50	0.88	0.25	6	.250-20 x 1.25 LG	1.500	1472340100	1481740100
1.375	2.50	3.00	0.63	1.00	0.25	6	.312-18 x 1.50 LG	2.000	1472340138	1481740138
1.750	3.00	4.00	0.63	1.25	0.25	8	.312-18 x 1.75 LG	2.375	1472340175	1481740175
2.000	3.50	4.00	0.75	1.63	0.38	12	.375-16 x 2.25 LG	2.687	1472340200	1481740200
2.500	4.00	4.50	0.75	1.88	0.38	12	.375-16 x 2.50 LG	3.187	1472340250	1481740250
3.000	5.00	5.50	1.00	2.38	0.38	12	.500-13 x 3.25 LG	4.000	1472340300	1481740300
3.500	5.88	7.00	1.00	2.63	0.38	12	.625-11 x 3.50 LG	4.687	1472340350	1481740350
4.000	6.38	7.00	1.00	2.63	0.38	12	.625-11 x 3.50 LG	5.187	1472340400	1481740400
4.500	6.88	8.00	1.00	3.13	0.38	12	.625-11 x 4.00 LG	5.687	1472340450	1481740450
5.000	7.38	8.00	1.00	3.13	0.38	12	.625-11 x 4.00 LG	6.187	1472340500	1481740500
5.500	8.25	9.00	1.25	3.88	0.38	12	.750-10 x 5.00 LG	6.875	1472340550	1481740550
7.000	10.38	11.00	1.75	4.00	0.50	12	1.00-8 x 5.50 LG	8.750	1472340700	1481740700
8.000	11.38	12.00	2.00	4.00	0.50	16	1.00-8 x 5.50 LG	9.750	1472340800	1481740800
9.000	13.12	14.00	2.25	4.00	0.50	12	1.25-7 x 6.00 LG	11.125	1472340900	1481740900
10.000	14.12	15.00	2.50	4.50	0.50	16	1.25-7 x 6.50 LG	12.125	1472341000	1481741000

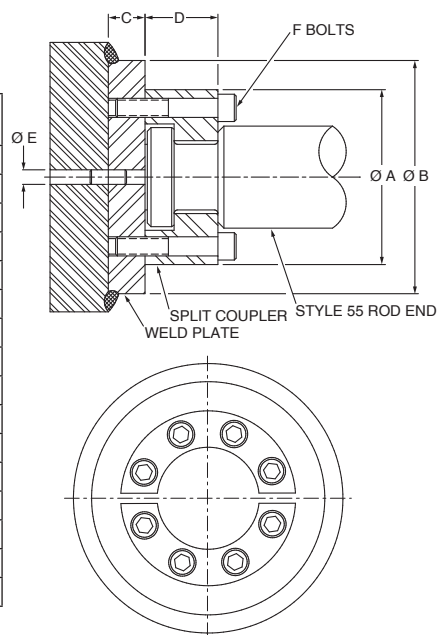

Note: Bolts are not included with split coupler or weld plate.

**WARNING:** Piston rod separation from the machine member can result in severe personal injury or even death to nearby personnel. The cylinder user must make sure the weld holding the weld plate to the machine is of sufficient quality and size to hold the intended load. The cylinder user must also make sure the bolts holding split coupler to the weld plate are of sufficient strength to hold the intended load and installed in such a way that they will not become loose during the machine's operation.

### Dual Axis Knuckles

Using a Dual Axis Knuckle permits increased angular movement from the cylinder center line. Clevis or Eye mounted cylinders often require movement beyond the plane that two pivot pins allow. Spherical bearing mounts permit angular movement up to 4.5° within the pivoting

plane. A Dual Axis Knuckle, with two pin holes 90° apart, installed at the cap and rod end of a mounting style BB cylinder adds two pivot points, thereby providing up to 30° movement in another plane at each end.

### Maximum Achievable Angular Movement from Cylinder Centerline<sup>1</sup>

**Inboard Pin - 15°** maximum movement for cylinder misalignment only.

**Outboard Pin - 30°** maximum movement when applying force to a load moving in a curved plane.

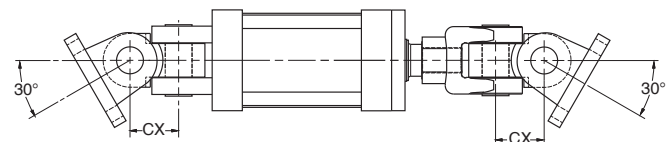
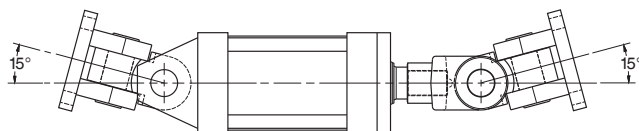

<sup>1</sup> Maximum movement is achieved with cast clevis brackets. Movement is reduced when using fabricated clevis brackets.

### Dual Axis Knuckle Dimensions and Usage

Part Number	Pin Ø	Load Cap. (lb)	CB	CD Ø	CX	LE	LR	MR	Mating Parts		BB Mount Usage by Series & Bore 2H, 2HD, 2HB
									Clevis Bracket	Rod Clevis	
0952670000	0.500	4,380	0.75	0.503	0.88	0.54	0.63	0.50	0960160050	0509400000, 0509410000	1.50
0952680000	0.750	12,370	1.25	0.753	1.19	0.80	0.94	0.75	0960160075	0509420000, 1332840000	2.00, 2.50
0952690000	1.000	20,500	1.50	1.003	1.69	1.05	1.22	1.00	0960160100	0509430000, 0509440000, 1332850000	3.25
0952700000	1.375	30,500	2.00	1.378	2.38	1.44	1.69	1.38	0960160138	0509450000, 1332860000	4.00
0952710000	1.750	49,500	2.50	1.753	3.06	1.81	2.19	1.75	0960160175	0509460000	5.00
0952720000	2.000	68,000	2.50	2.003	3.63	2.09	2.44	2.00	0960160200	0509470000, 0509480000	6.00

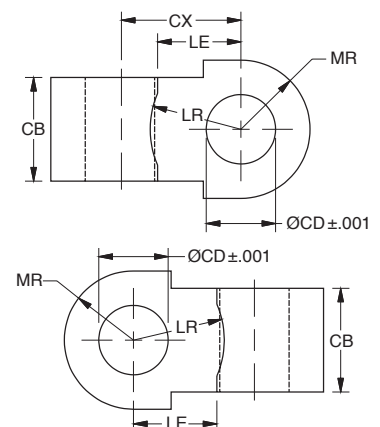

**PROP 65 WARNING** WARNING: This product can expose you to chemicals including **Lead and Lead Compounds** which are known to the State of California to cause cancer and birth defects or other reproductive harm. For more information go to [www.P65Warnings.ca.gov](http://www.P65Warnings.ca.gov)

**1.50" - 8.00" Bore Series PH**

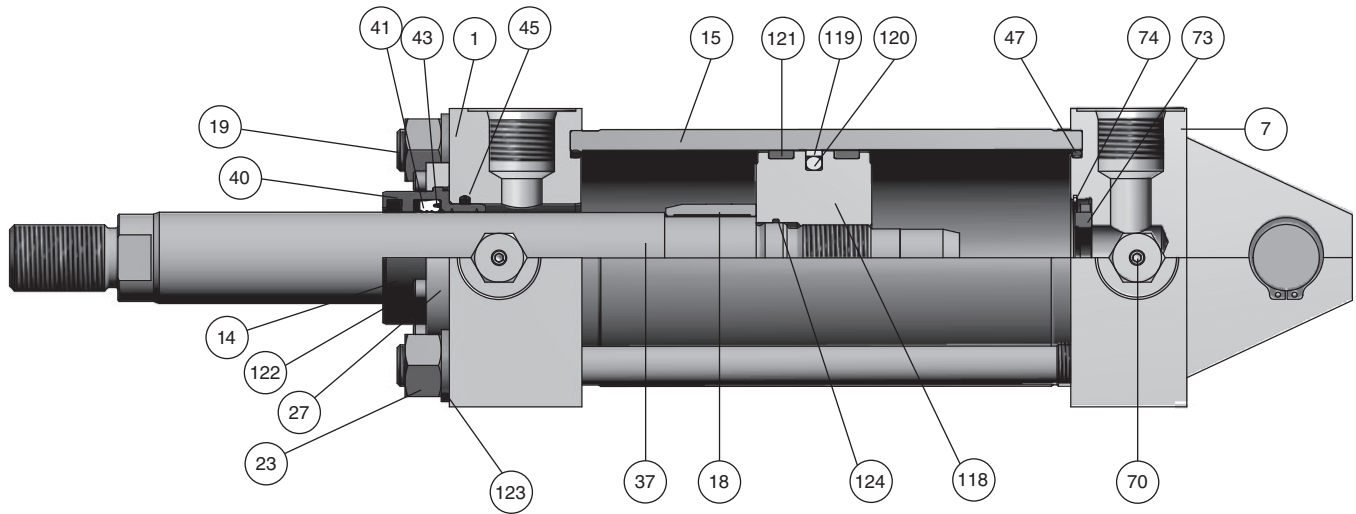

**Piston and Rod Assemblies**

Factory assembled piston and rod assemblies (that include seals for piston type specified) are recommended.

**Parts List — 1.50" through 8.00" Bore**

Symbol	Description
1	Head
7	Cap
14	Rod Gland
15	Cylinder Body
18	Cushion Sleeve, head end cushion
19	Tie Rod
23	Tie Rod Nut
27	Retainer
37	Piston Rod, single rod type
40	Rod Wiper
41	Rod Seal
43	Back-up Washer, rod seal

Symbol	Description
45	Gland O-Ring
47	O-Ring, cylinder tube to head and cap seal
70	Needle Valve, cushion adjustment cartridge
73	Bushing, float check, cushion on cap end
74	Retaining Ring, float check cushion bushing
118	Piston
119	Piston Seal
120	Piston Seal Energizer
121	Wear Ring
122	Retainer Bolt
123	Washer, tie rod nut
124	O-Ring, piston to rod seal

**⚠ PROP 65 WARNING** **WARNING:** This product can expose you to chemicals including **Lead and Lead Compounds** which are known to the State of California to cause cancer and birth defects or other reproductive harm. For more information go to [www.P65Warnings.ca.gov](http://www.P65Warnings.ca.gov)

Gland Cartridge Kits and Rod Seal Kits

Rod Dia.	Class 1 Service (Polyurethane & Nitrile)		Class 3 Service (EPR)		Class 5 Service (FKM)		Class 2 & 6 Service (Nitroxile)	
	Contains 1 ea. Sym, #41,40,41 & 45		Contains 1 ea. Sym, #41,40,41 & 45		Contains 1 ea. Sym, #41,40,41 & 45		Contains 1 ea. Sym, #41,40,41 & 45	
	Gland Cartridge Kits	Rod Seal Kits	Gland Cartridge Kits	Rod Seal Kits	Gland Cartridge Kits	Rod Seal Kits	Gland Cartridge Kits	Rod Seal Kits
0.625	H-RG110-63	H-RK110-63	H-RG310-63	H-RK310-63	H-RG510-63	H-RK510-63	H-RG210-63	H-RK210-63
1.000	H-RG110-100	H-RK110-100	H-RG310-100	H-RK310-100	H-RG510-100	H-RK510-100	H-RG210-100	H-RK210-100
1.375	H-RG110-138	H-RK110-138	H-RG310-138	H-RK310-138	H-RG510-138	H-RK510-138	H-RG210-138	H-RK210-138
1.750	H-RG110-175	H-RK110-175	H-RG310-175	H-RK310-175	H-RG510-175	H-RK510-175	H-RG210-175	H-RK210-175
2.000	H-RG110-200	H-RK110-200	H-RG310-200	H-RK310-200	H-RG510-200	H-RK510-200	H-RG210-200	H-RK210-200
2.500	H-RG110-250	H-RK110-250	H-RG310-250	H-RK310-250	H-RG510-250	H-RK510-250	H-RG210-250	H-RK210-250
3.000	H-RG110-300	H-RK110-300	H-RG310-300	H-RK310-300	H-RG510-300	H-RK510-300	H-RG210-300	H-RK210-300
3.500	H-RG110-350	H-RK110-350	H-RG310-350	H-RK310-350	H-RG510-350	H-RK510-350	H-RG210-350	H-RK210-350
4.000	H-RG110-400	H-RK110-400	H-RG310-400	H-RK310-400	H-RG510-400	H-RK510-400	H-RG210-400	H-RK210-400
4.500	H-RG110-450	H-RK110-450	H-RG310-450	H-RK310-450	H-RG510-450	H-RK510-450	H-RG210-450	H-RK210-450
5.000	H-RG110-500	H-RK110-500	H-RG310-500	H-RK310-500	H-RG510-500	H-RK510-500	H-RG210-500	H-RK210-500
5.500	H-RG110-550	H-RK110-550	H-RG310-550	H-RK310-550	H-RG510-550	H-RK510-550	H-RG210-550	H-RK210-550

<sup>1</sup>Rod Seal Kits do not includes Sym. #14

Series Crown Wiper  
Gland Cartridge Kits and Rod Seal Kits

Rod Dia.	Class 1 Service (Polyurethane & Nitrile)		Class 5 Service (FKM)		Retainer Bolt Torque (Torque values are for bolts installed with lubrication)
	Contains 1 ea. Sym, #41,40,41 & 45		Contains 1 ea. Sym, #41,40,41 & 45		
	Crown Wiper Gland Cartridge Kits	Crown Wiper Rod Seal Kits	Crown Wiper Gland Cartridge Kits	Crown Wiper Rod Seal Kits	
0.625	H-RG11C-63	H-RK11C-63	H-RG51C-63	H-RK51C-63	40 - 42 lb-in
1.000	H-RG11C-100	H-RK11C-100	H-RG51C-100	H-RK51C-100	40 - 42 lb-in
1.375	H-RG11C-138	H-RK11C-138	H-RG51C-138	H-RK51C-138	46 - 58 lb-in
1.750	H-RG11C-175	H-RK11C-175	H-RG51C-175	H-RK51C-175	46 - 58 lb-in
2.000	H-RG11C-200	H-RK11C-200	H-RG51C-200	H-RK51C-200	11 - 12 ft-lb
2.500	H-RG11C-250	H-RK11C-250	H-RG51C-250	H-RK51C-250	11 - 12 ft-lb
3.000	H-RG11C-300	H-RK11C-300	H-RG51C-300	H-RK51C-300	23 - 25 ft-lb
3.500	H-RG11C-350	H-RK11C-350	H-RG51C-350	H-RK51C-350	23 - 25 ft-lb
4.000	H-RG11C-400	H-RK11C-400	H-RG51C-400	H-RK51C-400	41 - 43 ft-lb
4.500	H-RG11C-450	H-RK11C-450	H-RG51C-450	H-RK51C-450	41 - 43 ft-lb
5.000	H-RG11C-500	H-RK11C-500	H-RG51C-500	H-RK51C-500	41 - 43 ft-lb
5.500	H-RG11C-550	H-RK11C-550	H-RG51C-550	H-RK51C-550	41 - 43 ft-lb

Rod Gland Cartridge Kit and Rod Seal Kit Parts Identification

- Gland Cartridge Kits contain items 14, 40, 41 and 45 (43 in class 2, 5 & 6 kits only)
- Rod Seal Kits contain items 40, 41 and 45 (43 in class 2, 5 & 6 kits only)

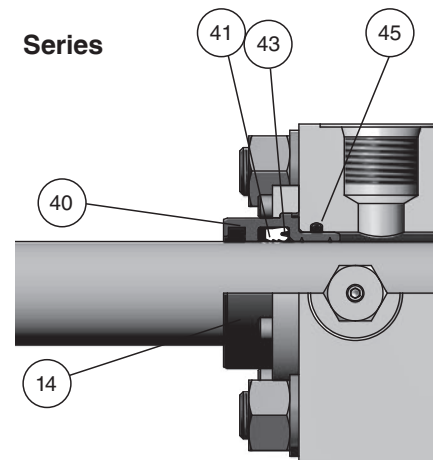

Engineering Data

**PROP 65 WARNING** WARNING: This product can expose you to chemicals including **Lead and Lead Compounds** which are known to the State of California to cause cancer and birth defects or other reproductive harm. For more information go to [www.P65Warnings.ca.gov](http://www.P65Warnings.ca.gov)

**Piston Seal Kits – Series RP – Includes cylinder body end seals**

Bore Size	Piston Seal RP, No Magnet				
	Class 1 Service	Class 2,6 Service	Class 3 Service	Class 4 Service	Class 5 Service
	Contains two each #47, 121, and one each #119 & 120	Contains two each #47, 121, and one each #119 & 120	Contains two each #47, 121, and one each #119 & 120	Contains two each #47, 121, and one each #119 & 120	Contains two each #47, 121, and one each #119 & 120
1.50	H-KBR01-150	H-KBR02-150	H-KBR03-150	H-KBR04-150	H-KBR05-150
2.00	H-KBR01-200	H-KBR02-200	H-KBR03-200	H-KBR04-200	H-KBR05-200
2.50	H-KBR01-250	H-KBR02-250	H-KBR03-250	H-KBR04-250	H-KBR05-250
3.25	H-KBR01-325	H-KBR02-325	H-KBR03-325	H-KBR04-325	H-KBR05-325
4.00	H-KBR01-400	H-KBR02-400	H-KBR03-400	H-KBR04-400	H-KBR05-400
5.00	H-KBR01-500	H-KBR02-500	H-KBR03-500	H-KBR04-500	H-KBR05-500
6.00	H-KBR01-600	H-KBR02-600	H-KBR03-600	H-KBR04-600	H-KBR05-600
7.00	H-KBR01-700	H-KBR02-700	H-KBR03-700	H-KBR04-700	H-KBR05-700
8.00	H-KBR01-800	H-KBR02-800	H-KBR03-800	H-KBR04-800	H-KBR05-800

Bore Size	Piston Seal RP, With Magnet				
	Class 1 Service	Class 2,6 Service	Class 3 Service	Class 4 Service	Class 5 Service
	Contains two each #47 and one each #119, 120 & 121	Contains two each #47 and one each #119, 120 & 121	Contains two each #47 and one each #119, 120 & 121	Contains two each #47 and one each #119, 120 & 121	Contains two each #47 and one each #119, 120 & 121
1.50	H-KBRM1-150	H-KBRM2-150	H-KBRM3-150	H-KBRM4-150	H-KBRM5-150
2.00	H-KBRM1-200	H-KBRM2-200	H-KBRM3-200	H-KBRM4-200	H-KBRM5-200
2.50	H-KBRM1-250	H-KBRM2-250	H-KBRM3-250	H-KBRM4-250	H-KBRM5-250
3.25	H-KBRM1-325	H-KBRM2-325	H-KBRM3-325	H-KBRM4-325	H-KBRM5-325
4.00	H-KBRM1-400	H-KBRM2-400	H-KBRM3-400	H-KBRM4-400	H-KBRM5-400
5.00	H-KBRM1-500	H-KBRM2-500	H-KBRM3-500	H-KBRM4-500	H-KBRM5-500
6.00	H-KBRM1-600	H-KBRM2-600	H-KBRM3-600	H-KBRM4-600	H-KBRM5-600
7.00	N/A	N/A	N/A	N/A	N/A
8.00	N/A	N/A	N/A	N/A	N/A

Tie Rod Torque 1.50 - 4.00	1.50	2.00	2.50	3.25	4.00
	18 - 19 lb-ft	45 - 49 lb-ft	45 - 49 lb-ft	120 - 124 lb-ft	131 - 135 lb-ft

Tie Rod Torque 5.00 - 8.00	5.00	6.00	7.00	8.00
	312 - 316 lb-ft	528 - 544 lb-ft	800 - 816 lb-ft	1168 - 1184 lb-ft

Note: The tie rod torque values are for cylinders rated at 3,000 psi. Consult the factory for torque values for cylinders rated above 3,000 psi

Note: Item 47, cylinder body end seal, is not shown.

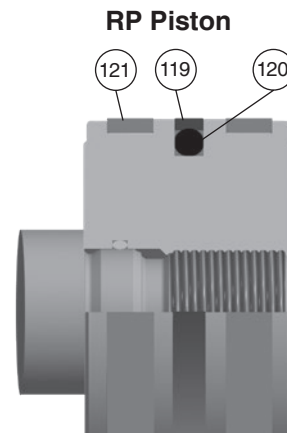

Engineering Data

**⚠ PROP 65 WARNING** WARNING: This product can expose you to chemicals including **Lead and Lead Compounds** which are known to the State of California to cause cancer and birth defects or other reproductive harm. For more information go to [www.P65Warnings.ca.gov](http://www.P65Warnings.ca.gov)

**Piston Seal Kits – Series WP – Includes cylinder body end seals**

Bore Size	Piston Seal WP, With Magnet			
	Class 1 Service	Class 2,6 Service	Class 3 Service	Class 5 Service
	Contains two each #47 and one each #119, 120 & 121	Contains two each #47 and one each #119, 120 & 121	Contains two each #47 and one each #119, 120 & 121	Contains two each #47 and one each #119, 120 & 121
1.50	H-KBWM1-150	H-KBWM2-150	H-KBWM3-150	H-KBWM5-150
2.00	H-KBWM1-200	H-KBWM2-200	H-KBWM3-200	H-KBWM5-200
2.50	H-KBWM1-250	H-KBWM2-250	H-KBWM3-250	H-KBWM5-250
3.25	H-KBWM1-325	H-KBWM2-325	H-KBWM3-325	H-KBWM5-325
4.00	H-KBWM1-400	H-KBWM2-400	H-KBWM3-400	H-KBWM5-400
5.00	H-KBWM1-500	H-KBWM2-500	H-KBWM3-500	H-KBWM5-500
6.00	H-KBWM1-600	H-KBWM2-600	H-KBWM3-600	H-KBWM5-600
7.00	N/A	N/A	N/A	N/A
8.00	N/A	N/A	N/A	N/A

Bore Size	Piston Seal WP, No Magnet			
	Class 1 Service	Class 2,6 Service	Class 3 Service	Class 5 Service
	Contains two each #47, 121, and one each #119 & 120	Contains two each #47, 121, and one each #119 & 120	Contains two each #47, 121, and one each #119 & 120	Contains two each #47, 121, and one each #119 & 120
1.50	H-KBW01-150	H-KBW02-150	H-KBW03-150	H-KBW05-150
2.00	H-KBW01-200	H-KBW02-200	H-KBW03-200	H-KBW05-200
2.50	H-KBW01-250	H-KBW02-250	H-KBW03-250	H-KBW05-250
3.25	H-KBW01-325	H-KBW02-325	H-KBW03-325	H-KBW05-325
4.00	H-KBW01-400	H-KBW02-400	H-KBW03-400	H-KBW05-400
5.00	H-KBW01-500	H-KBW02-500	H-KBW03-500	H-KBW05-500
6.00	H-KBW01-600	H-KBW02-600	H-KBW03-600	H-KBW05-600
7.00	H-KBW01-700	H-KBW02-700	H-KBW03-700	H-KBW05-700
8.00	H-KBW01-800	H-KBW02-800	H-KBW03-800	H-KBW05-800

Tie Rod Torque 1.50 - 4.00	1.50	2.00	2.50	3.25	4.00
	18 -19 lb-ft	45 -49 lb-ft	45 -49 lb-ft	120 -124 lb-ft	131 -135 lb-ft

Tie Rod Torque 5.00 - 8.00	5.00	6.00	7.00	8.00
	312 -316 lb-ft	528 -544 lb-ft	800 -816 lb-ft	1168 -1184 lb-ft

Note: The tie rod torque values are for cylinders rated at 3,000 psi. Consult the factory for torque values for cylinders rated above 3,000 psi

<sup>1</sup> Item 119 for piston style WP (model number code W) includes both the PTFE primary seal and the redundant quad ring seal.

<sup>2</sup> The 1.50" bore WP seal groove is unique and not universal to the other seal styles. Changing an existing 1.50" bore cylinder either from or to a WP piston seal requires that a new piston and rod assembly be ordered.

Note: Item 47, cylinder body end seal, is not shown.

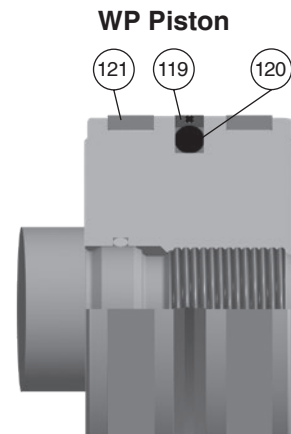

Engineering Data

**⚠ PROP 65 WARNING** WARNING: This product can expose you to chemicals including **Lead and Lead Compounds** which are known to the State of California to cause cancer and birth defects or other reproductive harm. For more information go to [www.P65Warnings.ca.gov](http://www.P65Warnings.ca.gov)

**Piston Seal Kits – Series HP – Includes cylinder body end seals**

Bore Size	Piston Seal HP, No Magnet	
	Class 1 Service	Class 4 Service
	Contains two each #47, 121, and one each #119 & 120	Contains two each #47, 121, and one each #119 & 120
	1.50	H-KBH01-150
2.00	H-KBH01-200	H-KBH04-200
2.50	H-KBH01-250	H-KBH04-250
3.25	H-KBH01-325	H-KBH04-325
4.00	H-KBH01-400	H-KBH04-400
5.00	H-KBH01-500	H-KBH04-500
6.00	H-KBH01-600	H-KBH04-600
7.00	H-KBH01-700	H-KBH04-700
8.00	H-KBH01-800	H-KBH04-800

Bore Size	Piston Seal HP, With Magnet	
	Class 1 Service	Class 4 Service
	Contains two each #47 and one each #119, 120 & 121	Contains two each #47 and one each #119, 120 & 121
1.50	H-KBHM1-150	H-KBHM4-150
2.00	H-KBHM1-200	H-KBHM4-200
2.50	H-KBHM1-250	H-KBHM4-250
3.25	H-KBHM1-325	H-KBHM4-325
4.00	H-KBHM1-400	H-KBHM4-400
5.00	H-KBHM1-500	H-KBHM4-500
6.00	H-KBHM1-600	H-KBHM4-600
7.00	N/A	N/A
8.00	N/A	N/A

Tie Rod Torque	1.50	2.00	2.50	3.25	4.00
1.50 - 4.00	18 -19 lb-ft	45 -49 lb-ft	45 -49 lb-ft	120 -124 lb-ft	131 -135 lb-ft

Tie Rod Torque	5.00	6.00	7.00	8.00
5.00 - 8.00	312 -316 lb-ft	528 -544 lb-ft	800 -816 lb-ft	1168 -1184 lb-ft

Note: The tie rod torque values are for cylinders rated at 3,000 psi. Consult the factory for torque values for cylinders rated above 3,000 psi

Note: Item 47, cylinder body end seal, is not shown.

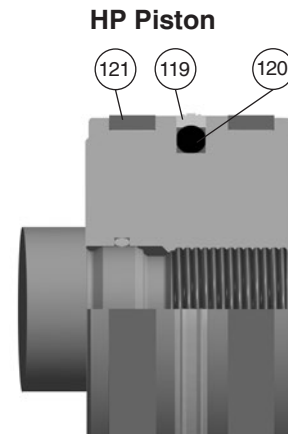

Engineering Data

**⚠ PROP 65 WARNING** WARNING: This product can expose you to chemicals including **Lead and Lead Compounds** which are known to the State of California to cause cancer and birth defects or other reproductive harm. For more information go to [www.P65Warnings.ca.gov](http://www.P65Warnings.ca.gov)

**Piston Seal Kits – Series KP – Includes cylinder body end seals**

Bore Size	Piston Seal KP, No Magnet					
	Class 1 Service	Class 2,6 Service	Class 3 Service	Class 4 Service	Class 5 Service	Class 8 Service
	Contains two each #47, 121, and one each #119 & 120	Contains two each #47, 121, and one each #119 & 120	Contains two each #47, 121, and one each #119 & 120	Contains two each #47, 121, and one each #119 & 120	Contains two each #47, 121, and one each #119 & 120	Contains two each #47, 121, and one each #119 & 120
1.50	H-KBK01-150	H-KBK02-150	H-KBK03-150	H-KBK04-150	H-KBK05-150	H-KBK08-150
2.00	H-KBK01-200	H-KBK02-200	H-KBK03-200	H-KBK04-200	H-KBK05-200	H-KBK08-200
2.50	H-KBK01-250	H-KBK02-250	H-KBK03-250	H-KBK04-250	H-KBK05-250	H-KBK08-250
3.25	H-KBK01-325	H-KBK02-325	H-KBK03-325	H-KBK04-325	H-KBK05-325	H-KBK08-325
4.00	H-KBK01-400	H-KBK02-400	H-KBK03-400	H-KBK04-400	H-KBK05-400	H-KBK08-400
5.00	H-KBK01-500	H-KBK02-500	H-KBK03-500	H-KBK04-500	H-KBK05-500	H-KBK08-500
6.00	H-KBK01-600	H-KBK02-600	H-KBK03-600	H-KBK04-600	H-KBK05-600	H-KBK08-600
7.00	H-KBK01-700	H-KBK02-700	H-KBK03-700	H-KBK04-700	H-KBK05-700	H-KBK08-700
8.00	H-KBK01-800	H-KBK02-800	H-KBK03-800	H-KBK04-800	H-KBK05-800	H-KBK08-800

Bore Size	Piston Seal K, With Magnet				
	Class 1 Service	Class 2,6 Service	Class 3 Service	Class 4 Service	Class 5 Service
	Contains two each #47 and one each #119, 120 & 121	Contains two each #47 and one each #119, 120 & 121	Contains two each #47 and one each #119, 120 & 121	Contains two each #47 and one each #119, 120 & 121	Contains two each #47 and one each #119, 120 & 121
1.50	H-KBKM1-150	H-KBKM2-150	H-KBKM3-150	H-KBKM4-150	H-KBKM5-150
2.00	H-KBKM1-200	H-KBKM2-200	H-KBKM3-200	H-KBKM4-200	H-KBKM5-200
2.50	H-KBKM1-250	H-KBKM2-250	H-KBKM3-250	H-KBKM4-250	H-KBKM5-250
3.25	H-KBKM1-325	H-KBKM2-325	H-KBKM3-325	H-KBKM4-325	H-KBKM5-325
4.00	H-KBKM1-400	H-KBKM2-400	H-KBKM3-400	H-KBKM4-400	H-KBKM5-400
5.00	H-KBKM1-500	H-KBKM2-500	H-KBKM3-500	H-KBKM4-500	H-KBKM5-500
6.00	H-KBKM1-600	H-KBKM2-600	H-KBKM3-600	H-KBKM4-600	H-KBKM5-600
7.00	N/A	N/A	N/A	N/A	N/A
8.00	N/A	N/A	N/A	N/A	N/A

Tie Rod Torque 1.50 - 4.00	1.50	2.00	2.50	3.25	4.00
	18 -19 lb-ft	45 -49 lb-ft	45 -49 lb-ft	120 -124 lb-ft	131 -135 lb-ft

Tie Rod Torque 5.00 - 8.00	5.00	6.00	7.00	8.00
	312 -316 lb-ft	528 -544 lb-ft	800 -816 lb-ft	1168 -1184 lb-ft

Note: The tie rod torque values are for cylinders rated at 3,000 psi. Consult the factory for torque values for cylinders rated above 3,000 psi

Note: Item 47, cylinder body end seal, is not shown.

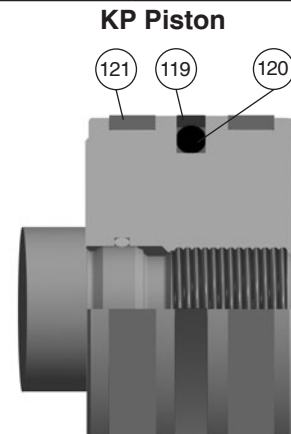

Engineering Data

**⚠ PROP 65 WARNING** WARNING: This product can expose you to chemicals including **Lead and Lead Compounds** which are known to the State of California to cause cancer and birth defects or other reproductive harm. For more information go to [www.P65Warnings.ca.gov](http://www.P65Warnings.ca.gov)

**10.00" - 20.00" Bore**

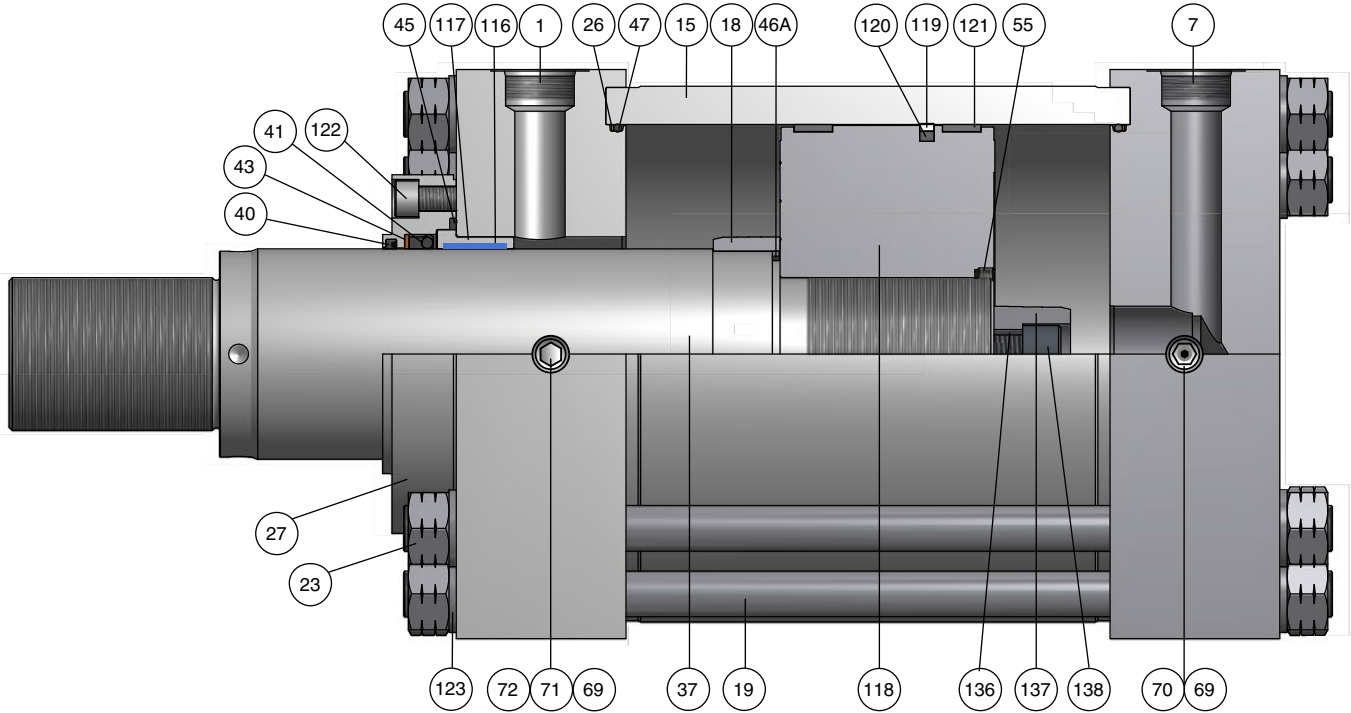

Symbol	Description
1	Head
7	Cap
15	Cylinder Body
18	Cushion Sleeve, head end cushion
19	Tie Rod
23	Tie Rod Nut
26	Back-up Washer, tube end seal
27	Retainer
37	Piston Rod, single rod type
40	Rod Wiperseal
41	Rod Seal
43	Back-up Washer, rod seal
45	Gland O-Ring
46A	Cushion Sealing Ring
47	O-Ring, cylinder tube to head and cap seal

Symbol	Description
55	Set Screw, piston lock
70	Cushion Adjusting Needle Assembly
72, 71, 69	Check Valve Screw, Ball, O-Ring
116	Wear Ring Rod
117	Rod Bushing (Gland)
118	Piston
119	Piston Seal
119 A	Quad (WP only) Ring (see closeup below)
120	Piston Seal Energizer
121	Wear Ring
122	Retainer Bolt
123	Washer, tie rod nut
136	Spacer, cushion
137	Cushion Spear, detachable
138	Bolt, cushion spear

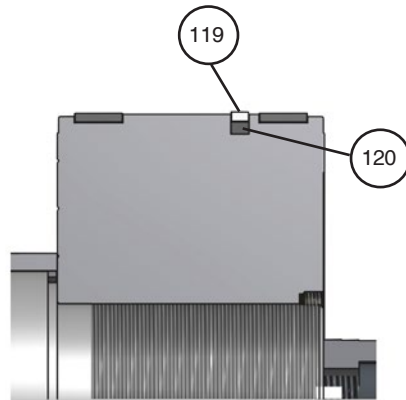

**Standard HP Style  
 Piston Seal**

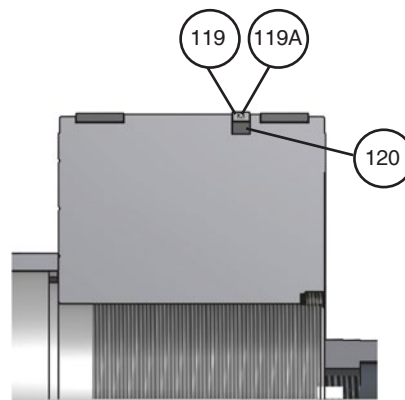

**Optional WP Style  
 Mixed Media Piston Seal**

**⚠ PROP 65 WARNING** WARNING: This product can expose you to chemicals including **Lead and Lead Compounds** which are known to the State of California to cause cancer and birth defects or other reproductive harm. For more information go to [www.P65Warnings.ca.gov](http://www.P65Warnings.ca.gov)





**10.00" - 20.00" Bore**

**Large Bore Rod Seal Kits**

Rod Dia.	Rod Seal Kits (including Wear Ring)			Rod Seal Kits (including Wear Ring & Bushing)		
	Contains Symbols			Contains Symbols		
	40, 41, 43, 45, 116			40, 41, 43, 45, 116, 117		
	CLASS 1	CLASS 2	CLASS 5	CLASS 1	CLASS 2	CLASS 5
4.500	H-RKL110-450	H-RKL210-450	H-RKL510-450	H-RGL110-450	H-RGL210-450	H-RGL510-450
5.000	H-RKL110-500	H-RKL210-500	H-RKL510-500	H-RGL110-500	H-RGL210-500	H-RGL510-500
5.500	H-RKL110-550	H-RKL210-550	H-RKL510-550	H-RGL110-550	H-RGL210-550	H-RGL510-550
7.000	H-RKL110-700	H-RKL210-700	H-RKL510-700	H-RGL110-700	H-RGL210-700	H-RGL510-700
8.000	H-RKL110-800	H-RKL210-800	H-RKL510-800	H-RGL110-800	H-RGL210-800	H-RGL510-800
9.000	H-RKL110-900	H-RKL210-900	H-RKL510-900	H-RGL110-900	H-RGL210-900	H-RGL510-900
10.000	H-RKL110-1000	H-RKL210-1000	H-RKL510-1000	H-RGL110-1000	H-RGL210-1000	H-RGL510-1000

Ø Rod	Retainer Bolt Torques	
	Nom. Bolt Size	Torque
4.500	1/2	100 - 105 lb-ft
5.000	5/8	185 - 194 lb-ft
5.500	5/8	185 - 194 lb-ft
7.000	1/2	100 - 105 lb-ft
8.000	3/4	330 - 346 lb-ft
9.000	3/4	330 - 346 lb-ft
10.000	3/4	330 - 346 lb-ft

Ø Bore	Tie Rod Torques
10.00	800 - 850 lb-ft
12.00	1300 - 1350 lb-ft
14.00	1175 - 1225 lb-ft
16.00	2900 - 3000 lb-ft
18.00	2350 - 2450 lb-ft
20.00	2900 - 3000 lb-ft

Ø Bore	Cylinder Body End Seals		
	Contains Symbols		
	(2X) 47	(2X) 26, (2X) 47	
	Group 1	Group 2	Group 5
10.00	CB1003HG01	CB1003HG02	CB1003HG05
12.00	CB1203HG01	CB1203HG02	CB1203HG05
14.00	CB1403HG01	CB1403HG02	CB1403HG05
16.00	CB1603HG01	CB1603HG02	CB1603HG05
18.00	CB1803HG01	CB1803HG02	CB1803HG05
20.00	CB2003HG01	CB2003HG02	CB2003HG05

**Large Bore Piston Seal Kits**

Bore	Piston Seal Kits			
	Contains Symbols			
	Contains two ea. 47, 121 and one ea. 119, 120, 119A (WP Kit only)			
	HP CLASS 1	KP CLASS 1	RP CLASS 1	WP CLASS 1
10.00	H-KBH01-1000	H-KBK01-1000	H-KBR01-1000	H-KBW01-1000
12.20	H-KBH01-1200	H-KBK01-1200	H-KBR01-1200	H-KBW01-1200
14.00	H-KBH01-1400	H-KBK01-1400	H-KBR01-1400	H-KBW01-1400
16.00	H-KBH01-1600	H-KBK01-1600	H-KBR01-1600	H-KBW01-1600
18.00	H-KBH01-1800	H-KBK01-1800	H-KBR01-1800	H-KBW01-1800
20.00	H-KBH01-2000	H-KBK01-2000	H-KBR01-2000	H-KBW01-2000

Bore	Piston Seal Kits					
	Contains Symbols					
	Contains two ea. 26, 47, 121 and one ea. 119, 120, 119A (WP Kit only)					
	KP CLASS 2	RP CLASS 2	WP CLASS 2	KP CLASS 5	RP CLASS 5	WP CLASS 5
10.00	H-KBK02-1000	H-KBR02-1000	H-KBW02-1000	H-KBK05-1000	H-KBR05-1000	H-KBW05-1000
12.20	H-KBK02-1200	H-KBR02-1200	H-KBW02-1200	H-KBK05-1200	H-KBR05-1200	H-KBW05-1200
14.00	H-KBK02-1400	H-KBR02-1400	H-KBW02-1400	H-KBK05-1400	H-KBR05-1400	H-KBW05-1400
16.00	H-KBK02-1600	H-KBR02-1600	H-KBW02-1600	H-KBK05-1600	H-KBR05-1600	H-KBW05-1600
18.00	H-KBK02-1800	H-KBR02-1800	H-KBW02-1800	H-KBK05-1800	H-KBR05-1800	H-KBW05-1800
20.00	H-KBK02-2000	H-KBR02-2000	H-KBW02-2000	H-KBK05-2000	H-KBR05-2000	H-KBW05-2000

**⚠ PROP 65 WARNING** WARNING: This product can expose you to chemicals including **Lead and Lead Compounds** which are known to the State of California to cause cancer and birth defects or other reproductive harm. For more information go to [www.P65Warnings.ca.gov](http://www.P65Warnings.ca.gov)

**Notes**

 **PROP 65 WARNING** **WARNING:** This product can expose you to chemicals including **Lead and Lead Compounds** which are known to the State of California to cause cancer and birth defects or other reproductive harm. For more information go to [www.P65Warnings.ca.gov](http://www.P65Warnings.ca.gov)

## Section E

### Custom Modifications

Magnetic Piston	86
Magnetic Switch Choices: Tie Rod Mounted ALS and Global Switches	87
Head and Cap Mounted End-of-Stroke Proximity Switches	88-91
Water Submersible Option and How to Order	92-93
Buffer Seal Gland, Rod End Styles and Seal Kits	94-95
Metallic Rod Scraper, Crown Wiper, Rod End Boots, Gland Drain and Air Bleeds	96
Tie Rod Supports, Stroke Adjusters, Thrust Key Mountings and Metric Piston Rod Thread	97
Global Shield™ Rod Coating Technology	98

 **PROP 65 WARNING** WARNING: This product can expose you to chemicals including **Lead and Lead Compounds** which are known to the State of California to cause cancer and birth defects or other reproductive harm. For more information go to [www.P65Warnings.ca.gov](http://www.P65Warnings.ca.gov)

## Series PH Magnetic Piston

### Position Sensing Technology for Hydraulic Cylinders – 1.50" thru 6.00" Bore

#### Customer Value Proposition

Schrader Bellows's magnetic sensing option for heavy duty hydraulic cylinders provides OEM's and end users the ability to sense piston position economically and reliably through the use of innovative magnet and switching technology. The magnetic piston option offers all users the ability to eliminate added cylinder

machining costs, stand alone external brackets / hardware and reduced system set-up time. By incorporating sensing capability into hydraulic cylinders, the need to install, wire and adjust stand alone proximity switches can be eliminated – thus providing a clean and more efficient position monitoring system.

#### Series PH Cylinder with magnetic piston

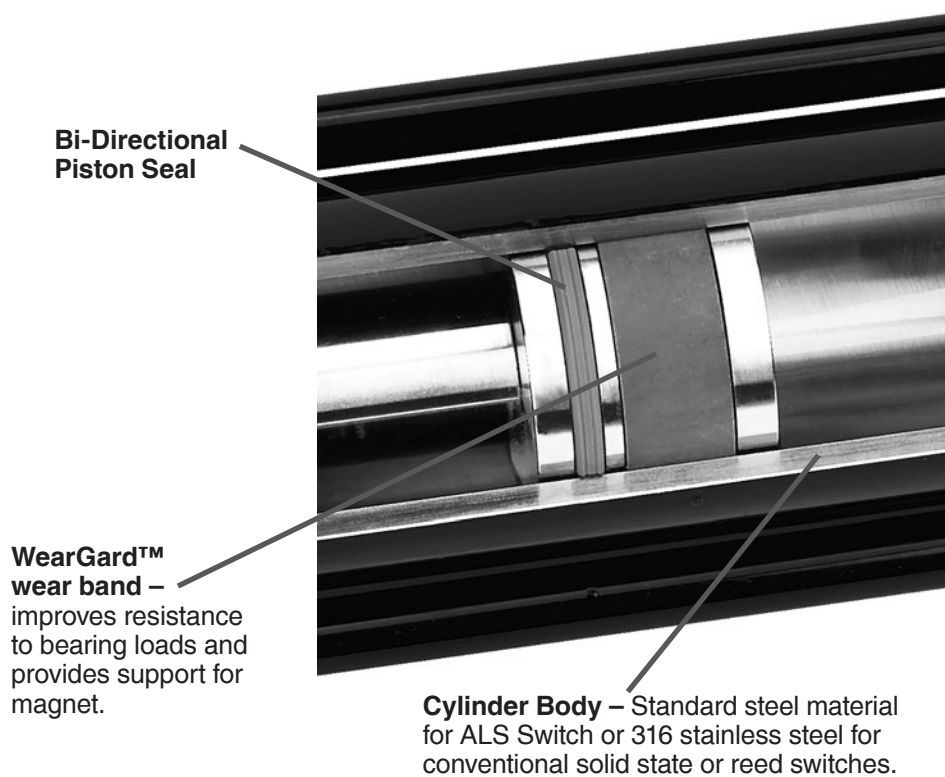

**Bi-Directional Piston Seal**

**WearGard™ wear band** – improves resistance to bearing loads and provides support for magnet.

**Cylinder Body** – Standard steel material for ALS Switch or 316 stainless steel for conventional solid state or reed switches.

#### Sensing Technologies

- Schrader Bellows's ALS switch works with a magnetic piston in a standard steel tube by detecting the change in polarity of the steel material as the magnet passes under the switch. Standard steel tube is more economical in longer strokes than non-ferrous stainless steel tubes required for conventional sensors. Solid State ALS switches are available in both PNP and NPN outputs and can be wired either normally open or normally closed. Magnetic piston with steel tube for ALS switches is available 1.50" – 6.00" bore and is specified with a '7' in the Piston Magnet field of the cylinder model number.
- Schrader Bellows Global Switches are available in both Reed and Solid State types. Solid State switches are available in both PNP and NPN outputs. They work with a magnetic piston in a 316 stainless steel tube. Magnetic piston with a stainless steel tube for Global Switches is available 1.50" – 4.00" bore and is specified with a '3' in the Piston Magnet field of the cylinder model number.

**⚠ PROP 65 WARNING** WARNING: This product can expose you to chemicals including **Lead and Lead Compounds** which are known to the State of California to cause cancer and birth defects or other reproductive harm. For more information go to [www.P65Warnings.ca.gov](http://www.P65Warnings.ca.gov)

### Magnetic Switch Choices

Schrader Bellows's ALS switch and Global switch are designed to offer customers an alternative means of sensing hydraulic cylinder piston position. Depending on the application, and the budget, one switch type may be better suited to fulfill customer needs than the other.

Some of the important things to consider when deciding which technology to choose are shown below. For more details on ALS and Global switches as well as other position sensing options see catalog HY08-1132.

#### ALS Switch



- Compatible with standard steel tube
- +10 to +30 VDC power requirement
- PNP/NPN wired NO or NC
- Solid state construction
- 2 LED indicators (power & target)
- 12mm connector
- IP 67 rated
- Temperature Range: -25°C to +85°C
- Short circuit protection

#### ALS Switch Kit Part Numbers

Switches are packaged with a mounting bracket.

Part Number		Switch Bracket Usage
PNP	NPN	
ALS-PH	ALS-NH	Series 2H 1.50 – 4.00 Bore
ALS-PHA	ALS-NHA	Series 2H 5.00 & 6.00 Bore

#### Minimum Stroke for ALS Switch

Bore Ø	Minimum Stroke
1.50	3.00
2.00	3.00
2.50	2.88
3.25	2.75

Bore Ø	Minimum Stroke
4.00	2.63
5.00	2.38
6.00	2.19

ALS Switches allow a .38 - .50 inch stroke-to-go piston travel for end-of-stroke mounting locations.

#### Global Switch

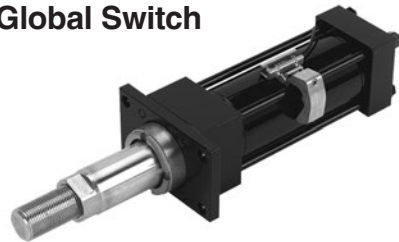

- Uses 316 stainless steel tube
- +10 to +30 VDC power requirement
- PNP/NPN, Reed
- Solid state construction
- 1 power LED indicator
- 8mm connector or flying leads
- IP67 rated
- Temperature Range: -25°C to + 75°C
- Short circuit protection

#### Global Drop-In Switches



Wiring	Reed	PNP	NPN
3m Flying Leads	P8S-GRFAX	P8S-GPFAX	P8S-GNFAX
10m Flying Leads	P8S-GRFDX	P8S-GPFDX	P8S-GNFDX
0.3m Lead with 8mm connector	P8S-GRCHX	P8S-GPCHX	P8S-GNCHX

Wiring	PNP Switch ATEX Certified	PNP Switch High Temperature
3m Flying Leads	P8S-GPFLX/EX	P8S-GPFLH

Global switch tie rod mounting bracket, part number P8S-TMA0X, must be ordered separately.

**⚠ PROP 65 WARNING** WARNING: This product can expose you to chemicals including **Lead and Lead Compounds** which are known to the State of California to cause cancer and birth defects or other reproductive harm. For more information go to [www.P65Warnings.ca.gov](http://www.P65Warnings.ca.gov)

**EPS 7 & 6 Sensors  
 Inductive Proximity**

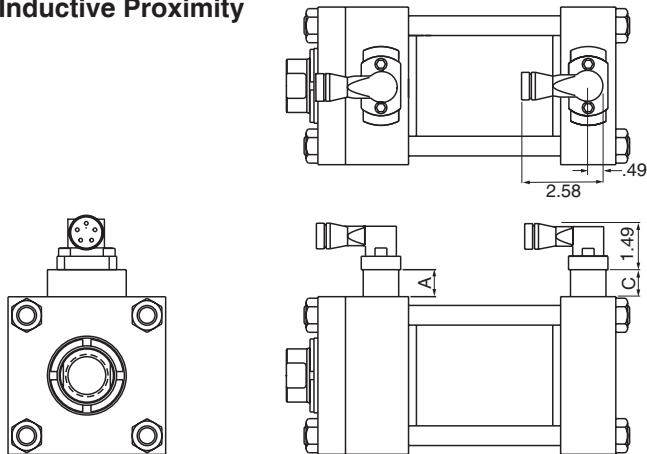

**CLS 1 & 4 Sensors  
 Non-Contacting  
 Magnetically  
 Actuated**

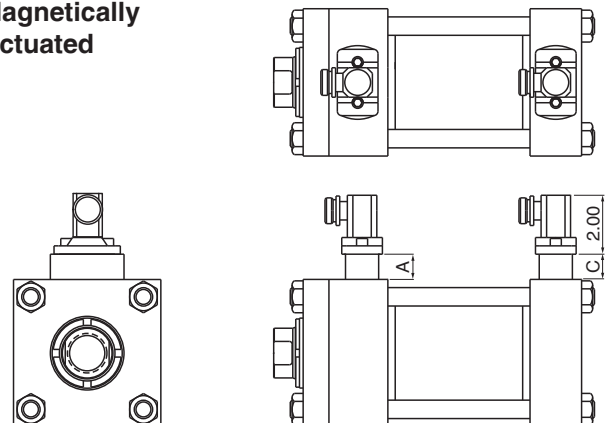

**Spacer Height  
 EPS & CLS Sensors**

A max.	C max.
.86	1.75

For exact dimensions, see Bulletin 0840-G-E1.

**Connector Pin Numbering**

**3-Pin Mini**

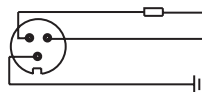

**EPS-7**

**5-Pin Mini**

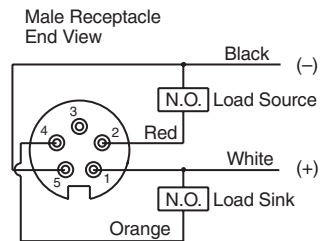

**EPS-6**

**Series and Parallel Wiring**

When Schrader Bellows EPS-6 or 7 sensors are used as inputs to programmable controllers the preferred practice is to connect each sensor to a separate input channel of the PLC. Series or parallel operations may then be accomplished by the internal PLC programming.

Schrader Bellows EPS-6 or 7 sensors may be hard wired for series operation, but the voltage drop through the sensors (see specifications) must not reduce the available voltage below what is needed to actuate the load.

Schrader Bellows EPS-6 or 7 sensors may also be hard wired for parallel operation. However, the leakage current of each sensor will pass through the load. The total of all leakage currents must not exceed the current required to actuate the load. In most cases, the use of two or more EPS-6 or 7 sensors in parallel will require the use of a bypass (shunt) resistor.

**Minimum Stroke**

The minimum stroke for EPS-6 or 7 and CLS-1 or 4 sensors, utilizing standard components, is the cushion sleeve or spear length for the cylinder series in which the sensor is installed. See the Cushion Length Chart in this catalog for details. Contact the factory if a shorter stroke is required.

**⚠ PROP 65 WARNING** WARNING: This product can expose you to chemicals including **Lead and Lead Compounds** which are known to the State of California to cause cancer and birth defects or other reproductive harm. For more information go to [www.P65Warnings.ca.gov](http://www.P65Warnings.ca.gov)

### CLS-2 Threaded Style Switches

Spacers are not required. Threaded switches can be adjusted for small changes to end of stroke position sensing.

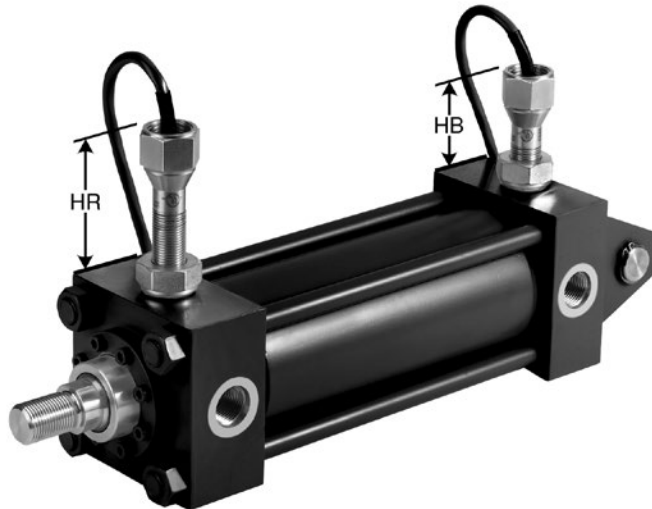

#### Switch Height

Bore Ø	Rod Ø	HR	HB
1.50	0.625	2.56	3.31
	1.000	2.75	
2.00	1.000	2.56	3.25
	1.375	2.69	
2.50	1.000	2.31	2.94
	1.375	2.50	
	1.750	2.69	
3.25	1.375	2.94	2.56
	1.750	3.13	
	2.000	3.31	
4.00	1.750	2.88	2.44
	2.000	3.06	
	2.500	2.50	
5.00	2.000	2.31	2.31
	2.500	2.63	
	3.000	2.88	
	3.500	3.13	
6.00	2.500	2.13	3.00
	3.000	2.38	
	3.500	2.63	
	4.000	2.88	
7.00	3.000	3.38	2.69
	3.500	2.13	
	4.000	2.38	
	4.500	2.63	
8.00	5.000	3.00	2.25
	3.500	3.13	
	4.000	3.38	
	4.500	2.13	
	5.000	2.50	
	5.500	2.69	

As shown in the illustrations below, these switches are magnetically operated. Dual magnets provide a dependable “snap action” for positive position sensing.

In the “Unoperated” position, the magnet assembly is attracted in the opposite direction of the arrow, causing a finely ground stainless steel connecting rod to hold the contacts open.

In the “Operated” position a ferrous part (cushion or piston) enters the sensing area and attracts the magnet assembly which causes the rod to draw the contacts together.

#### Operating Principle

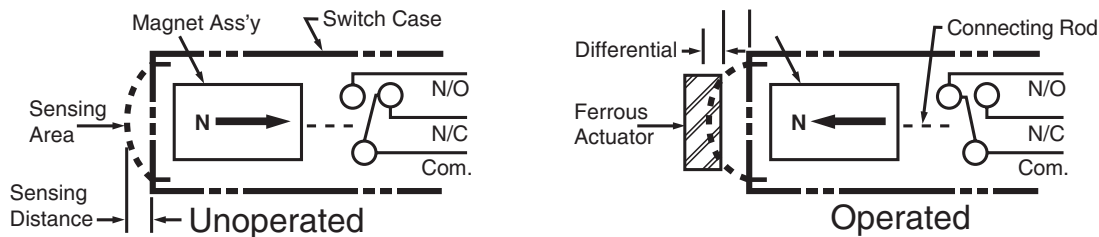

**Sensing gap:** .030" to .060"

**Trip point:** Factory set with piston bottomed out.

**Release point:** Approx. 0.25" piston travel.

Minimum cylinder stroke is .50" on 1.50" & 2.00" bores; and .75" on 2.50" bore and larger.

See the CLS Specification table for additional details.

**⚠ PROP 65 WARNING** WARNING: This product can expose you to chemicals including **Lead and Lead Compounds** which are known to the State of California to cause cancer and birth defects or other reproductive harm. For more information go to [www.P65Warnings.ca.gov](http://www.P65Warnings.ca.gov)

Specifications					
Style:	EPS-7	EPS-6	CLS-1	CLS-4	CLS-2
Code Designator:	H	D	F	B	G
<b>Description:</b>	Economical, General Purpose, 2 wire device, primarily for AC applications. (Not suitable for 3 wire 24 volt Sinking or Sourcing applications.) Also for automotive industry applications.	Economical, General Purpose, 3 wire, DC sensor, dual output: sinking and sourcing	Functional replacement for AB (Mechanical) Limit Switches in many applications, or where customer needs NC contacts, zero leakage, zero voltage drop, higher or lower load current than EPS-style	Functional replacement for AB (Mechanical) Limit Switches in many High Temperature applications, or where customer needs NC contacts, zero leakage, zero voltage drop, higher or lower load current than EPS-style.	For applications where the customer needs NC contacts, zero leakage, zero voltage drop, higher or lower load current than EPS style. Threaded style permits small adjustability of make/break location.
<b>Supply Voltage:</b>	20 to 250 VAC/DC	10 to 30 VDC	24 to 240 VAC/DC	24 to 240 VAC/DC	24 to 240 VAC/DC
<b>Load Current, min:</b>	8 mA	N/A	NA	NA	NA
<b>Load Current, max:</b>	300 mA	200 mA	4 AMPS @ 120 VAC 3 AMPS @ 24 VDC	4 AMPS @ 120 VAC 3 AMPS @ 24 VDC	4 AMPS @ 120 VAC 3 AMPS @ 24 VDC
<b>Leakage Current:</b>	1.7 mA, max.	10 micro amps max	-	-	-
<b>Voltage Drop:</b>	7 V, max.	2 VDC max.	N/A	NA	None
<b>Operating Temperature:</b>	-14° to +158° F	-14° to +158°F	-40°F to +221°F	-40°F to +400°F	-40°F to +221°F
<b>Sensor Type:</b>	Inductive proximity	Inductive proximity	non-contacting magnetically actuated	non-contacting magnetically actuated	non-contacting magnetically actuated
<b>Part Number:</b>	148897 <sup>1</sup>	148896 <sup>1</sup>	148275 <sup>1</sup>	149109 <sup>1</sup>	117000, 117017, 117034
<b>Part Number Suffix<sup>1</sup>:</b>	'4-digit suffix indicates probe length: 0125=1.25", 0206=2.06", 0287=2.875", 0456=4.562"				Switch selection is application dependent – Contact Factory
<b>Connection:</b>	3 pin mini	5 pin mini	3 pin mini	144" PTFE Coated Flying Leads with 1/2" conduit hub	36" Potted-in PVC cable (most sizes also with 1/2" conduit hub)
<b>Enclosure Rating:</b>	IEC IP67	IEC IP67	NEMA 1, 2, 3, 4, 4x, 5, 6, 6P, 11, 12, 12K, 13	NEMA 1, 2, 3, 4, 4x, 5	NEMA 4, 4X, 6, 6P, 7, 9
<b>LED indication:</b>	Yes	Yes	Yes	No	No
<b>Short Circuit Protection:</b>	Yes	Yes	No	No	No
<b>Weld Field Immunity:</b>	Yes	Yes	Yes	Yes	Yes
<b>Output:</b>	2 wire, Normally Open with leakage current	Dual Output: DC Sinking and DC Sourcing, user selectable via wiring	SPDT (Single Pole Double Throw), Normally Open/ Normally Closed, Form C	SPDT (Single Pole Double Throw), Normally Open/ Normally Closed, Form C	SPDT (Single Pole Double Throw), Normally Open/ Normally Closed, Form C
<b>Approvals/Marks:</b>	CE, UL, CSA	CE, UL, CSA	UL or CSA <sup>2</sup>	UL or CSA <sup>2</sup>	UL or CSA <sup>2</sup>
<b>Make/Break Location:</b>	0.13" from end of stroke, typical. Tolerance is +0/-0.13"				-
<b>Wiring Instructions:</b>	Pin 1: AC Ground (Green) Pin 2: Output (Black) Pin 3: AC Line (White)	Pin 1: +10 to 30 VDC (White) Pin 2: Sourcing Output (Red) Pin 3: Grounded (not connected or required) Pin 4: Sinking Output (Orange) Pin 5: DC Common (Black)	Pin 1: Common (Green) Pin 2: Normally Closed (Black) Pin 3: Normally Open (White)	Common (Black) Normally Open (Blue) Normally Closed (Red)	Common (Black) Normally Open (Blue) Normally Closed (Red)
<b>Cable: 6'</b>	0853550006	0859170006	0853550006	-	-
<b>Cable: 12'</b>	0853550012	0859170012	0853550012	-	-
<b>Cable: 6', Right Angle</b>	0875470006	-	0875470006	-	-

<sup>2</sup>CSA available upon request – contact factory.

**⚠ PROP 65 WARNING** WARNING: This product can expose you to chemicals including **Lead and Lead Compounds** which are known to the State of California to cause cancer and birth defects or other reproductive harm. For more information go to [www.P65Warnings.ca.gov](http://www.P65Warnings.ca.gov)

Accessories / Parts



### How to Specify EPS Proximity Switches

Schrader Bellows EPS proximity switches may be ordered on Series PH cylinders as follows:

- 1) Complete the basic cylinder model number.
- 2) Place an "S" in the model number to denote switches and/or special features.
- 3) Mounting styles D, DB, JJ, J, or H should be used with caution because of possible mounting interferences. See Available Switch Position table below for additional details.
- 4) Special modifications to cylinders other than switches must have a written description.

5) Specify letter prefix "H" for EPS-7, "D" for EPS-6, and "F" for CLS-1, "B" for CLS-4 or "G" for CLS-2, then fill in the four blanks specifying port location, switch orientation and actuation point for both head and cap. If only one switch is used, place "XXXX" in the unused blanks.

Example = H13AGG-XXXX denotes a switch on the head end only, EPS-7

Example = XXXX-H42AGG denotes a switch on the cap end only, CLS-4

#### Head End

H	1	3	A	GG
Specify: "H" = EPS-7 "D" = EPS-6 "F" = CLS-1 <sup>1</sup> "B" = CLS-4 <sup>1</sup> "G" = CLS-2 "N" = Prep for EPS-6 and EPS-7 switches "P" = Prep for CLS-1 and CLS-4 switches "T" = Prep for CLS-2 switch	Port Location See Figure 1.	Switch Location See Figure 1.	Switch Orientation See Figure 2 for EPS-7, EPS-6, CLS-1 and CLS-4.	Actuation Point GG = End of Stroke FF = Stroke to Go <sup>2</sup> ; See Bulletins 0840-G-E1, 2 or 3 for stroke remaining.

#### Cap End

H	4	2	A	GG
Specify: "H" = EPS-7 "D" = EPS-6 "F" = CLS-1 <sup>1</sup> "B" = CLS-4 <sup>1</sup> "G" = CLS-2 "N" = Prep for EPS-6 and EPS-7 switches "P" = Prep for CLS-1 and CLS-4 switches "T" = Prep for CLS-2 switch	Port Location See Figure 1.	Switch Location See Figure 1.	Switch Orientation See Figure 2 for EPS-7, EPS-6, CLS-1 and CLS-4.	Actuation Point GG = End of Stroke FF = Stroke to Go <sup>2</sup> ; See Bulletins 0840-G-E1, 2 or 3 for stroke remaining.

Note: All specified switch and port locations are as seen from rod end of cylinder.

<sup>1</sup> CLS-1 and CLS-4 proximity switches are not available on the head end of 1.50" bore with 1.00" rod and 2.00" bore with 1.375" rod.

<sup>2</sup> FF Stroke to Go not available with CLS-2 switch.

#### Available Mounting Positions<sup>1</sup> for EPS-6, EPS-7, CLS-1, CLS-4

MOUNTING STYLES	Bore Ø								
	1.50	2.00	2.50	3.25	4.00	5.00	6.00	7.00	8.00
T,TB,TC, TD,BB,DD, DE,SB,SE	HEAD	1,2,3,4	1,2,3,4	1,2,3,4	1,2,3,4	1,2,3,4	1,2,3,4	1,2,3,4	1,2,3,4
	CAP	1,2,3,4	1,2,3,4	1,2,3,4	1,2,3,4	1,2,3,4	1,2,3,4	1,2,3,4	1,2,3,4
J,D,JJ <sup>2</sup>	HEAD	1,3	1,3	1,3	1,3	1,3	1,3	1,3	1,3
	CAP	1,2,3,4	1,2,3,4	1,2,3,4	1,2,3,4	1,2,3,4	1,2,3,4	1,2,3,4	1,2,3,4
H,DB,HH	HEAD	1,2,3,4	1,2,3,4	1,2,3,4	1,2,3,4	1,2,3,4	1,2,3,4	1,2,3,4	1,2,3,4
	CAP	1,3	1,3	1,3	1,3	1,3	1,3	1,3	1,3
C <sup>3</sup>	HEAD	1	1	1	1	1	1,2,4	1,2,4	1,2,4
	CAP	1	1	1	1	1	1,2,4	1,2,4	1,2,4
F	HEAD	1	1	1,2,4	1,2,4	1,2,4	1,2,4	1,2,4	1,2,4
	CAP	1	1	1,2,4	1,2,4	1,2,4	1,2,4	1,2,4	1,2,4
JB	HEAD	NA	NA	NA	1,2,3,4	1,2,3,4	1,2,3,4	1,2,3,4	1,2,3,4
	CAP	1,2,3,4	1,2,3,4	1,2,3,4	1,2,3,4	1,2,3,4	1,2,3,4	1,2,3,4	1,2,3,4
HB	HEAD	1,2,3,4	1,2,3,4	1,2,3,4	1,2,3,4	1,2,3,4	1,2,3,4	1,2,3,4	1,2,3,4
	CAP	NA	NA	NA	1,2,3,4	1,2,3,4	1,2,3,4	1,2,3,4	1,2,3,4

<sup>1</sup> Positions 1, 2, 3 and 4 are determined by viewing cylinder from piston rod end (See Figure 1). The electrical connector orientation may be restricted in some cases.

<sup>2</sup> On 1.50" - 5.00" bore Style JJ cylinders, switches will extend beyond mounting surface of cylinder.

<sup>3</sup> On 6.00" bore cylinders and larger switches mounted in position 2 or 4 will interfere with the installation and removal of mounting bolts.

Figure 1

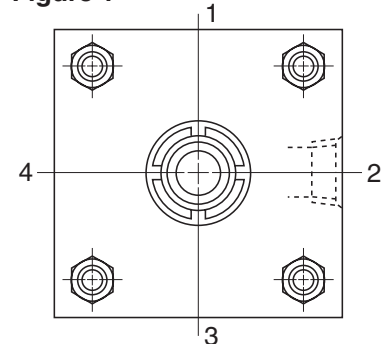
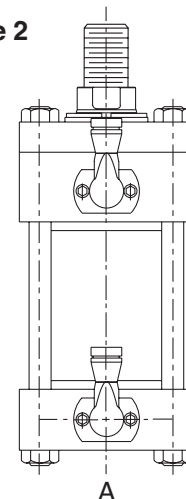

Figure 2



Accessories / Parts

**⚠ PROP 65 WARNING** WARNING: This product can expose you to chemicals including **Lead and Lead Compounds** which are known to the State of California to cause cancer and birth defects or other reproductive harm. For more information go to [www.P65Warnings.ca.gov](http://www.P65Warnings.ca.gov)

# Water Submersible Option for Series PH Hydraulic Cylinders

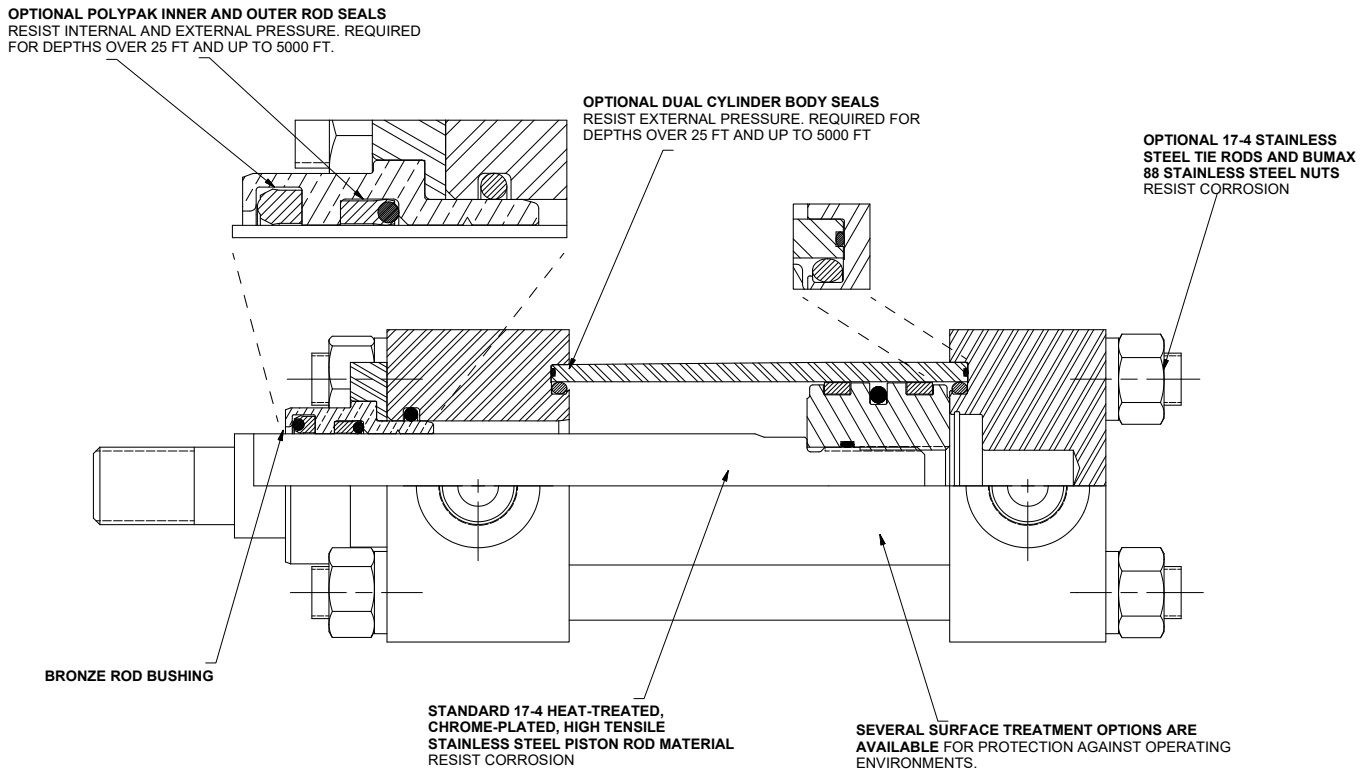

### Specifications:

- Submersion Depth: up to 5000 ft
- Heavy Duty Service – ANSI (NFPA) T3.6.7R2 – 1996 Specifications and Mounting Dimension Standards
- Nominal Pressure – 3000 psi
- Operating Temperature – -10°F to +165°F
- 17-4 PH chrome plated stainless steel piston rod
- Stainless steel name tag affixed with stainless steel wire around tie rod

### Cylinder Seal Construction:

- Up to 25 ft – Standard rod seal and body seals
- Over 25 ft to 5000 ft
  - Subsea rod seal package that includes a Polypak oil seal and an outward facing Polypak wiper to seal against water intrusion.
  - Subsea body seal package with ID oil seal and body-end o-ring to seal against water intrusion.
  - Not available with 0.625 Ø piston rod

### Standard Options for Water Submersible Cylinders:

#### Material

- 17-4 PH stainless steel tie rods and Bumax 88 stainless steel tie rod nuts
- Chrome plated body ID

#### Surface Treatments for Corrosion Protection

- Electroless nickel plated exterior (head, cap, body and retainer)
- Inorganic zinc primer (zinc primer only – without bond coating)
- Inorganic zinc primer with epoxy undercoat and anacrylic topcoat
- Epoxy undercoat and topcoat

### Custom Options available for Special Order:

- End-of-Stroke Switches
- All stainless steel construction



**⚠ PROP 65 WARNING** WARNING: This product can expose you to chemicals including **Lead and Lead Compounds** which are known to the State of California to cause cancer and birth defects or other reproductive harm. For more information go to [www.P65Warnings.ca.gov](http://www.P65Warnings.ca.gov)

# Water Submersible Option for Series PH Hydraulic Cylinders

**How to order:**

1. Specify the complete Schrader Bellows Cylinder Model Number.
2. Put an “S” in the model number to indicate a special cylinder.
3. Include the 3 digit Submersible Code.
4. For custom options, such as switches, provide a complete description or drawing of your requirements.

**Submersible Code**

When selecting the submersible option, an S must be placed in the Model Number. Select Submersible Code values for the required Submersion Depth, Cylinder Body, and Corrosion Protection. See the example Model Number below:

Feature	Code	Specification	For
Submersion Depth	1	Conventional rod gland and body seal design	Depths to 25 ft
	2	Submersible rod gland and dual cylinder body seals	Depths to 5000 ft
	3	Other	Specify depth / requirements
Cylinder Body	P	Plain ID	
	C	Chrome plated ID	
Corrosion Protection	1	Inorganic zinc primer	Splash & short term immersion service where equipment is top coated by the customer
	2	Inorganic zinc primer with stainless steel tie rods, nuts, & fasteners	
	3	Electroless nickel plated exterior with stainless steel tie rods, nuts, & fasteners	
	4	Inorganic zinc primer, epoxy undercoat, & anacrylic topcoat.	Splash & short term immersion service
	5	Inorganic zinc primer, epoxy undercoat, & anacrylic topcoat with stainless steel tie rods, nuts, & fasteners	
	6	Epoxy base & top coat.	
	7	Epoxy base & top coat. with stainless steel tie rods, nuts, & fasteners	Long term immersion service
9	Other	Specify requirements	

**Example:**

**4.00 BB PHK T S 14 X 24.00**

**S=Submersible Code: 2P1**

(describes a 4" x 24" cylinder for submersion up to 5000 ft, with a plain cylinder body ID and Inorganic Zinc Primer corrosion protection.)

**Water Submersible Codes and Features Supplied - Depths to 5000 ft<sup>1</sup>**

Submersible Cylinder Feature	Water Submersible Code <sup>1</sup>													
	2P1	2P2	2P3	2P4	2P5	2P6	2P7	2C1	2C2	2C3	2C4	2C5	2C6	2C7
17-4 PH piston rod	X	X	X	X	X	X	X	X	X	X	X	X	X	X
Stainless steel tag	X	X	X	X	X	X	X	X	X	X	X	X	X	X
Submersible rod gland	X	X	X	X	X	X	X	X	X	X	X	X	X	X
Dual cylinder body seals	X	X	X	X	X	X	X	X	X	X	X	X	X	X
Chrome plated cylinder ID								X	X	X	X	X	X	X
SS tie rods, nuts, & fasteners		X	X		X		X		X	X		X		X
Electroless nickel plated exterior			X							X				
Inorganic zinc primer	X	X						X	X					
Inorganic zinc primer with topcoats				X	X						X	X		
Epoxy base & topcoat						X	X						X	X

<sup>1</sup> Corresponding submersible codes for depths to 25 ft begin with 1 (e.g. 1P1, 1P2, etc.) and include all of the features marked for 5000 ft depth **except** Submersible Rod Gland and Dual Cylinder Body Seals.

**⚠ PROP 65 WARNING** WARNING: This product can expose you to chemicals including **Lead and Lead Compounds** which are known to the State of California to cause cancer and birth defects or other reproductive harm. For more information go to [www.P65Warnings.ca.gov](http://www.P65Warnings.ca.gov)

## Schrader Bellows Buffer Seal's Unique Design

The Schrader Bellows Buffer Seal Gland is recommended for heavy duty applications where pressure spikes on the rod side of the piston produce premature rod seal failure. Whether the pressure spikes are caused by an external

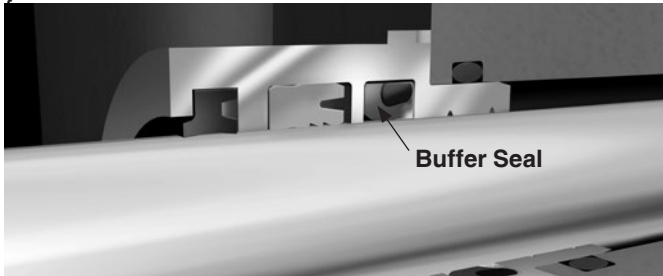

intensification due to differential piston areas, the resultant rod seal damage drives the need for more frequent unplanned service downtime.

Schrader Bellows Buffer Seal is a secondary, upstream seal that protects the primary rod seal from damage caused by pressure spikes. The polyurethane Buffer Seal for Class 1 service and filled PTFE Buffer Seal for all other Seal Classes is o-ring energized, low friction and extrusion resistant.

The Schrader Bellows Buffer Seal is a unique design that allows trapped pressure back into the cylinder. When the rod extends from the cylinder the Buffer Seal is riding on a high compression sealing point to limit leakage. On the retract stroke the seal rocks forward to allow trapped fluid to pass under the seal and return to the system.

Buffer Seals are available with Series PH in 1.50"-8.00" bores. They are available with Seal Classes 1, 2, 3, 4, 5 & 6. Selection of the Buffer Seal is made with a code in the cylinder model number.

## Rod Extension Dimensions for Buffer Seal Glands

Buffer Seal glands are from 0.31" to 0.81" longer (see table at right) than glands without a Buffer Seal. The longer gland causes the piston rod to extend beyond its location for a standard gland. A differentiating rod end style 4B vs. 4, 9B vs. 9 etc. must also be specified when selecting the Buffer Seal gland option. Rod end extension dimensions – V, VF, W, WF and WG – for Buffer Seal rod end styles are in the table at right. All other rod end dimensions are unchanged and can be found on the Piston Rod Ends page for each series.

### Rod End Dimensions

Bore Ø	Rod No.	MM Rod Ø	Gland Length Increase	V <sup>1</sup>	VF	W <sup>1</sup>	WF	WG <sup>2</sup>
1.50	1 (Std.)	0.625	Buffer Seal Not Available in 0.625" Rod					
	2	1.000	0.31	0.81	0.83	1.31	1.69	2.38
2.00	1 (Std.)	1.000	0.31	0.56	0.83	1.06	1.69	2.38
	2	1.375	0.38	0.75	1.02	1.38	2.00	2.75
2.50	1 (Std.)	1.000	0.31	0.56	0.83	1.06	1.69	2.38
	2	1.750	0.44	0.94	0.97	1.69	2.31	3.13
	3	1.375	0.38	0.75	1.02	1.38	2.00	2.75
3.25	1 (Std.)	1.375	0.38	0.63	1.02	1.25	2.00	2.75
	2	2.000	0.44	0.81	0.97	1.69	2.44	3.75
	3	1.750	0.44	0.81	0.97	1.56	2.31	3.13
4.00	1 (Std.)	1.750	0.44	0.69	0.97	1.44	2.31	3.13
	2	2.500	0.44	0.81	1.09	1.81	2.69	4.50
	3	2.000	0.44	0.69	0.97	1.56	2.44	3.75
5.00	1 (Std.)	2.000	0.44	0.69	0.97	1.56	2.44	3.75
	2	3.500	0.44	0.81	0.78	1.81	2.69	5.63
	3	2.500	0.44	0.81	1.09	1.81	2.69	4.50
	4	3.000	0.44	0.81	0.85	1.81	2.69	4.88
6.00	1 (Std.)	2.500	0.44	0.69	1.09	1.69	2.69	4.50
	2	4.000	0.44	0.69	0.78	1.69	2.69	5.75
	3	3.000	0.44	0.69	0.85	1.69	2.69	4.88
	4	3.500	0.44	0.69	0.78	1.69	2.69	5.63
7.00	1 (Std.)	3.000	0.44	1.06	0.84	1.69	2.69	4.88
	2	5.000	0.81	1.15	1.15	2.06	3.06	6.63
	3	3.500	0.44	1.07	0.78	1.69	2.69	5.63
	4	4.000	0.44	0.94	0.78	1.69	2.69	5.75
	5	4.500	0.44	0.94	0.78	1.69	2.69	6.50
8.00	1 (Std.)	3.500	0.44	1.06	0.78	1.69	2.69	5.63
	2	5.500	0.81	1.15	1.15	2.06	3.06	7.50
	3	4.000	0.44	0.94	0.78	1.69	2.69	5.75
	4	4.500	0.44	0.94	0.78	1.69	2.69	6.50
	5	5.000	0.81	1.15	1.15	2.06	3.06	6.63

### Series PH 1.50" - 8.00" Bore Rod End Styles

Style 4B – Small Male

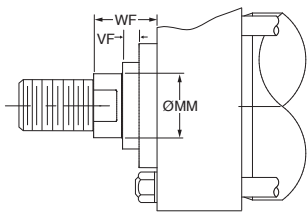

Style 8B – Intermediate Male

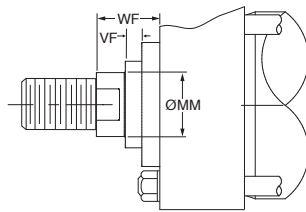

Style 9B – Short Female

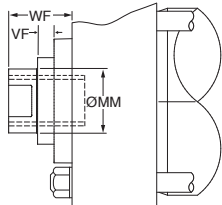

Style 55B – Flanged Rod End

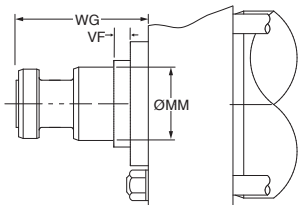

1 'V' and 'W' dimensions are for Mounting Styles J & JB and tie rod retained gland styles.

2 The 'WG' dimension for Buffer Seal Glands matches the 'WG' for standard glands.

**⚠ PROP 65 WARNING** WARNING: This product can expose you to chemicals including **Lead and Lead Compounds** which are known to the State of California to cause cancer and birth defects or other reproductive harm. For more information go to [www.P65Warnings.ca.gov](http://www.P65Warnings.ca.gov)

## 2HD/3HD & 2HB/3HB Buffer Seal Rod Gland Cartridge Kit and Rod Seal Kit Parts Identification

- Gland Cartridge Kits contain items 12, 13, 14, 40, 41 and 45 (43 in class 2, 5, and 6 kits only)
- Rod Seal Kits contain items 12, 13, 40, 41 and 45 (43 in class 2, 5 and 6 kits only)

### Parts List — Buffer Seal Gland

Symbol	Description
12	Buffer Seal
13	Buffer Seal Energizer
14	Rod Gland
40	Rod Wiper
41	Rod Seal
43	Back-up Washer, rod seal
45	Gland O-Ring

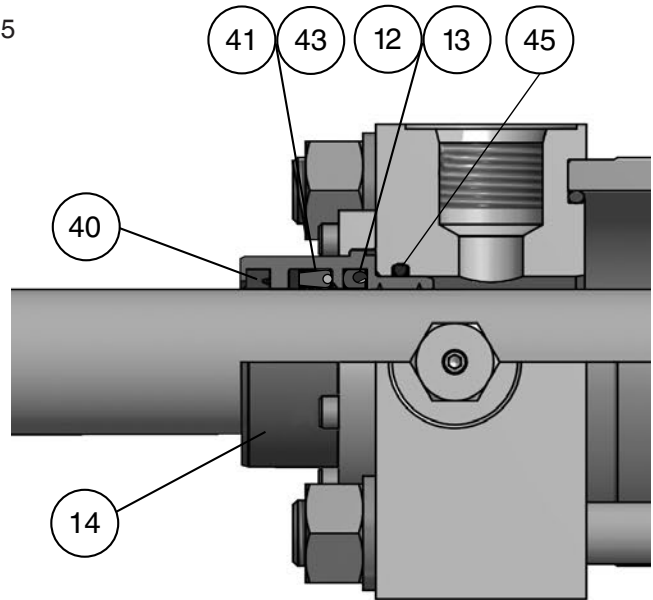

## Series PH Buffer Seal Gland Cartridge Kits and Rod Seal Kits

Rod Dia.	Seal Type							
	Class 1 Service		Class 2 Service		Class 3 Service		Class 5 Service	
	Contains 1 ea. Sym.# 14,40,41 & 45*		Contains 1 ea. Sym.# 14,40,41 & 45*		Contains 1 ea. Sym.# 14,40,41 & 45*		Contains 1 ea. Sym.# 14,40,41 & 45*	
	Gland Cartridge Kits	Rod Seal Kits	Gland Cartridge Kits	Rod Seal Kits	Gland Cartridge Kits	Rod Seal Kits	Gland Cartridge Kits	Rod Seal Kits
1.000	H-RG11B-100	H-RK11B-100	H-RG21B-100	H-RK21B-100	H-RG31B-100	H-RK31B-100	H-RG51B-100	H-RK51B-100
1.375	H-RG11B-138	H-RK11B-138	H-RG21B-138	H-RK21B-138	H-RG31B-138	H-RK31B-138	H-RG51B-138	H-RK51B-138
1.750	H-RG11B-175	H-RK11B-175	H-RG21B-175	H-RK21B-175	H-RG31B-175	H-RK31B-175	H-RG51B-175	H-RK51B-175
2.000	H-RG11B-200	H-RK11B-200	H-RG21B-200	H-RK21B-200	H-RG31B-200	H-RK31B-200	H-RG51B-200	H-RK51B-200
2.500	H-RG11B-250	H-RK11B-250	H-RG21B-250	H-RK21B-250	H-RG31B-250	H-RK31B-250	H-RG51B-250	H-RK51B-250
3.000	H-RG11B-300	H-RK11B-300	H-RG21B-300	H-RK21B-300	H-RG31B-300	H-RK31B-300	H-RG51B-300	H-RK51B-300
3.500	H-RG11B-350	H-RK11B-350	H-RG21B-350	H-RK21B-350	H-RG31B-350	H-RK31B-350	H-RG51B-350	H-RK51B-350
4.000	H-RG11B-400	H-RK11B-400	H-RG21B-400	H-RK21B-400	H-RG31B-400	H-RK31B-400	H-RG51B-400	H-RK51B-400
4.500	H-RG11B-450	H-RK11B-450	H-RG21B-450	H-RK21B-450	H-RG31B-450	H-RK31B-450	H-RG51B-450	H-RK51B-450
5.000	H-RG11B-500	H-RK11B-500	H-RG21B-500	H-RK21B-500	H-RG31B-500	H-RK31B-500	H-RG51B-500	H-RK51B-500
5.500	H-RG11B-550	H-RK11B-550	H-RG21B-550	H-RK21B-550	H-RG31B-550	H-RK31B-550	H-RG51B-550	H-RK51B-550

\*Rod seal kits do not include item 14.

Accessories / Parts

**⚠ PROP 65 WARNING** WARNING: This product can expose you to chemicals including **Lead and Lead Compounds** which are known to the State of California to cause cancer and birth defects or other reproductive harm. For more information go to [www.P65Warnings.ca.gov](http://www.P65Warnings.ca.gov)

**Modifications:** The following modifications can be supplied on most Schrader Bellows cylinders.

**Metallic Rod Scraper**

When specified metallic rod scrapers can be supplied instead of the standard synthetic rubber wiperseal. Recommended in applications where contaminants tend to cling to the extended piston rod and would damage the synthetic rubber wiperseal. Installation of metallic rod scraper does not affect cylinder dimensions. It is available at extra cost.

**Schrader Bellows Crown Wiper™ for Series PH  
1.50" thru 8.00" bore**

For environments that contain fine abrasive particulate specify the Crown Wiper option. The Crown Wiper is a proven superior alternative to piston rod end boots or metallic wipers that can ingest particulate. It has a sharp leading edge to effectively clean the piston rod and a beveled shape to prevent contaminant intrusion by channeling it away from the bushing. It also acts as a secondary seal to wipe clean any oil film adhering to the rod on the extend stroke.

Standard Crown Wiper material for Seal Class 1 and 4 service is durable polyurethane. Optional FKM material is available for Class 5 service. The Crown Wiper requires a unique bushing but does not change cylinder mounting dimensions

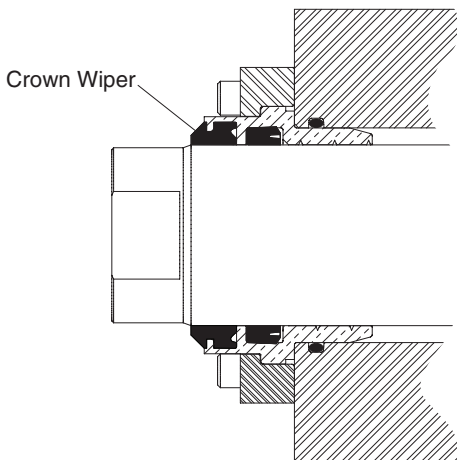

**Rod End Boots**

Cylinders have a hardened bearing surface on the piston rod to resist external damage, and are equipped with the high efficiency "Wiperseal" to remove external dust and dirt. Exposed piston rods that are subjected to contaminants with air hardening properties, such as paint, should be protected. In such applications, the use of a collapsing cover should be considered. This is commonly referred to as a "boot". Calculate the longer rod end required to accommodate the collapsed length of the boot from the following data.

<b>LF</b>	.13	.13	.13	.13	.13	.13	.10	.10	.10	.10	.10
<b>OD</b>	2.25	2.63	3.00	3.38	3.75	4.38	5.13	5.63	6.25	7.00	7.50
<b>MM</b>	.625	1.000	1.375	1.750	2.000	2.500	3.000	3.500	4.000	5.000	5.500

To determine extra length of piston rod required to accommodate boot, calculate  
 $BL = \text{Stroke} \times LF + 1.13"$   
 $BL + \text{Std. W or WF} + A = \text{length of piston rod to extend beyond the retainer.}$

NOTE: Check all Boot O.D's against std. "E" dimension from catalog. This may be critical on foot mounted cylinders.

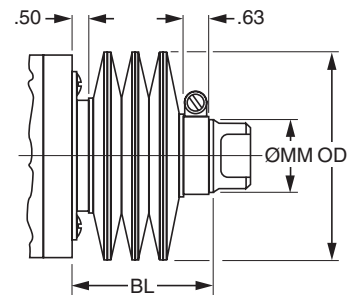

**Bushing Drain**

Hydraulic fluids tend to adhere to the piston rods, during the extend stroke, and an accumulation of fluid can collect in the cavity behind the bushing wiperseal on long stroke cylinders.

A 1/8" NPTF bushing drain port can be provided in the bushing retainer. A passage in the bushing between the wiperseal and lipseal is provided to drain off any accumulation of fluid between the seals. See drawing below.

It is recommended that the bushing drain port be piped back to the fluid reservoir and that the reservoir be located below the level of the head of the cylinder.

On 1.50" bore with 0.625" rod the drain port is located in the head adjacent to the port. The retainer thickness on 1.50" bore with 1.000" rod and bushing drain is increased to 0.63". On 2.00"-8.00" bore sizes the drain port is located in the retainer as shown. On Style JJ with bushing drain, the drain port is in the head.

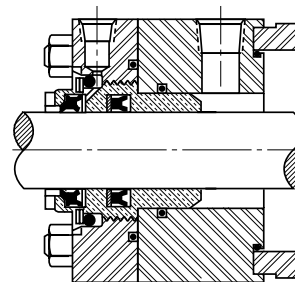

**Air Bleeds**

In most hydraulic circuits, cylinders are considered self-bleeding when cycled full stroke. If air bleeds are required and specified, 1/8" NPTF Air Bleed Ports for venting air can be provided at both ends of the cylinder body, or on the head or cap. To order, specify "Bleed Port", and indicate position desired.



**⚠ PROP 65 WARNING**

**WARNING:** This product can expose you to chemicals including **Lead and Lead Compounds** which are known to the State of California to cause cancer and birth defects or other reproductive harm. For more information go to [www.P65Warnings.ca.gov](http://www.P65Warnings.ca.gov)

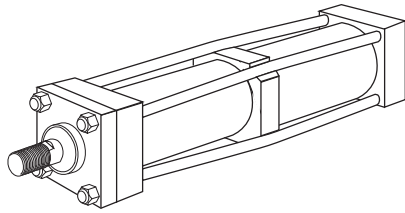

**Tie Rod Supports**

**Rigidity of Envelope** – Schrader Bellows heavy duty hydraulic cylinders have advantages in rigidity within the limits of the cylinder tube to resist buckling. For long stroke tie rod cylinders, within practical limits, Schrader Bellows provides Tie Rod Supports (see table below) that move the tie rod centerlines radially outward.

Standard tie rod supports are kept within the envelope dimensions of the head and cap, and generally do not interfere with mounting a long cylinder.

Number of Supports Required	Bore Ø	Stroke (Inches)										
		36	48	60	72	84	96	108	120	132	144	156
1.50	—	—	1	1	1	2	2	2	3	3	3	4
2.00	—	—	—	1	1	1	1	2	2	2	2	3
2.50	—	—	—	—	—	1	1	1	1	1	1	2
3.25	—	—	—	—	—	—	—	—	1	1	1	1
4.00	—	—	—	—	—	—	—	—	—	—	1	1

Note: 5.00" through 14.00" bore sizes — no supports required.

**Stroke Adjusters**

For the requirement where adjusting the stroke is specified. Schrader Bellows has several designs to offer, one of which is illustrated below. This is suitable for infrequent adjustment and is economical<sup>1</sup>.

Bore Ø	D	J	K	L (Max.)
1.50	1/2 - 20	0.31	0.94	5
2.00	3/4 - 16	0.44	1.25	8
2.50, 3.25	1 - 14	0.63	1.69	9
4.00	1 1/2 - 12	0.94	2.13	18
5.00	2 - 12	0.94	2.69	20
6.00	2 1/2 - 12	1.69	3.13	20
7.00	3 - 12	2.00	3.25	20
8.00	3 1/2 - 12	2.38	3.50	20

Here a “retracting stroke adjuster” must be called for in specifications, and the length of the adjustment must be specified.

Where frequent adjustment or cushions at the cap end are required, other designs are available according to application needs.

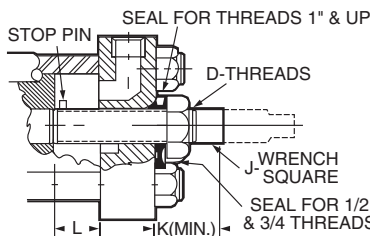

<sup>1</sup> Infrequent is defined by positioning the retract stroke in a couple of attempts at original machine set up. The frequent stroke adjuster is recommended for adjustments required after the original equipment has been adjusted by the original machine manufacturer.

**Thrust Key Mountings**

Thrust key mountings eliminate the need of using fitted bolts or external keys on side mounted cylinders. Schrader Bellows cylinders in mounting styles CP and FP can be provided with the bushing retainer plate extended below the mounting side of the cylinder (see illustration below). This extended retainer plate can then be fitted into a keyway milled into the mounting surface of the machine member. This is referred to as the “P” Modification of any side mounting style.

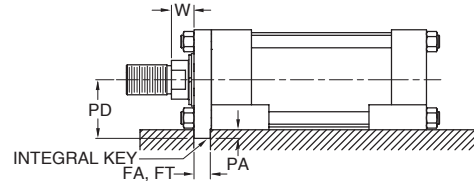

Bore Ø	FA	FT	PA	PD Mtg. Styles CP & FP
1.50	.361 -0.001 +0.000	.312 -0.002 +0.000	0.19	1.44
2.00	.611 -0.001 +0.000	.562 -0.002 +0.000	0.31	1.81
2.50	.611 -0.001 +0.000	.562 -0.002 +0.000	0.31	2.06
3.25	.736 -0.001 +0.000	.687 -0.003 +0.000	0.38	2.63
4.00	.861 -0.001 +0.000	.812 -0.003 +0.000	0.44	2.94
5.00	.861 -0.001 +0.000	.812 -0.003 +0.000	0.44	3.69
6.00	.986 -0.001 +0.000	.937 -0.003 +0.000	0.50	4.25
7.00	.986 -0.001 +0.000	.937 -0.003 +0.000	0.50	4.75
8.00	.986 -0.001 +0.000	.937 -0.003 +0.000	0.50	5.25

**Metric Piston Rod Thread**

The table below lists the standard thread supplied when Piston Rod Thread type M is specified in the cylinder model code.

MM Rod Ø	Thread		A
	Style 8M CC	Styles 4M & 9M KK	
0.625	M12x1.5	M10x1.5	0.75
1.000	M22x1.5	M20x1.5	1.13
1.375	M30x2	M26x1.5	1.63
1.750	M39x2	M33x2	2.00
2.000	M45x2	M39x2	2.25
2.500	M56x2	M48x2	3.00
3.000	M68x2	M58x2	3.50
3.500	M76x2	M64x2	3.50
4.000	M95x2	M76x2	4.00
4.500	M110x2	M80x2	4.50
5.000	M110x2	M90x2	5.00
5.500	M130x2	M100x2	5.50
7.000	-	M125x4	7.00
8.000	-	M140x4	8.00
9.000	-	M160x4	9.00
10.000	-	M180x4	10.00

**⚠ PROP 65 WARNING** WARNING: This product can expose you to chemicals including **Lead and Lead Compounds** which are known to the State of California to cause cancer and birth defects or other reproductive harm. For more information go to [www.P65Warnings.ca.gov](http://www.P65Warnings.ca.gov)

## Global Shield™ Rod Coating Technology

### A Dramatically Different Approach to Resisting Corrosion

Schrader Bellows's **Global Shield** rod coating technology is specifically designed to address corrosion resistance requirements of challenging industrial applications. When compared to traditional rod coatings, **Global Shield** has the following advantages:

- **Significantly Improved Corrosion Resistance** from the single-layer, fully dense, submicron structure and the lack of micro cracks inherent to chrome plating.
- **Lower Friction**
- **Ductile and Tough** so when the rod bends, it does too
- **Engineered Hardness** (HRC 54 minimum) for wear-resistance

The **value** that you will receive from **Global Shield** includes:

- **Less Downtime** from reduced maintenance intervals (cylinder repairs and seal replacements)
- **Longer Seal Life** in corrosive environments
- **Lower Service Costs** since you won't need to replace the piston rod due to corrosion

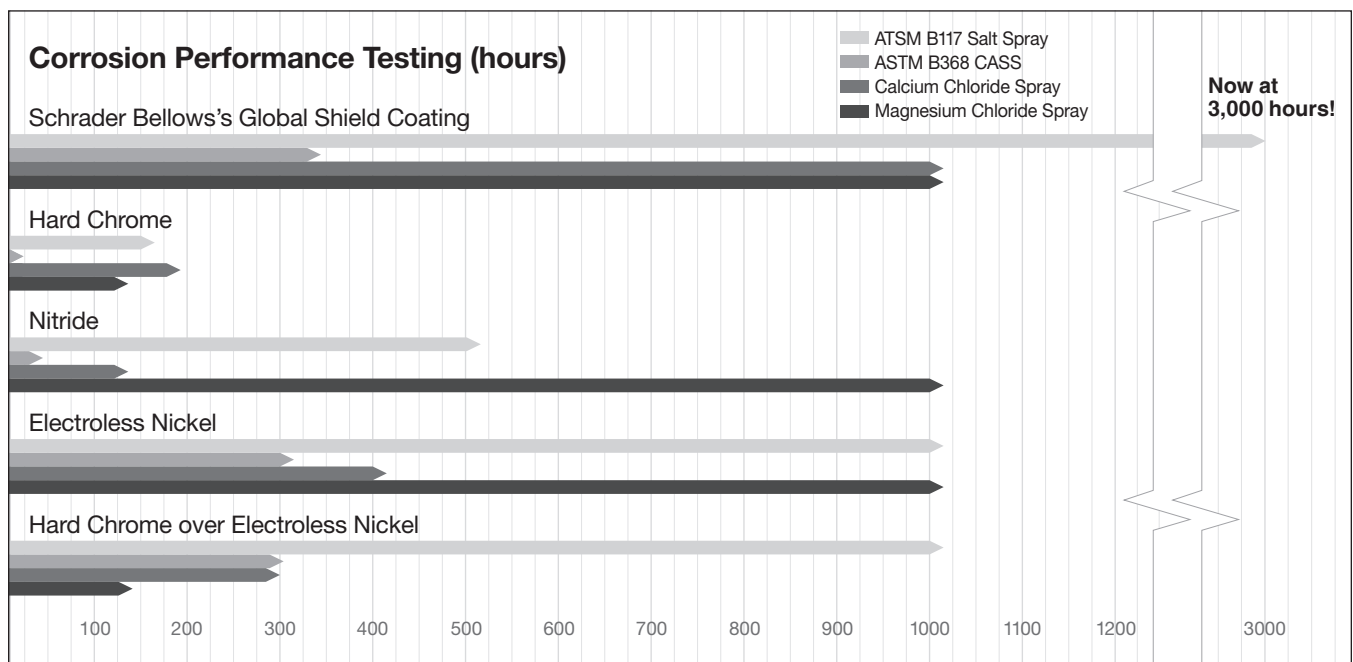

### Performance Validated in the Lab and in the field

This breakthrough proprietary technology, owned and manufactured by Parker Hannifin Corporation, has been thoroughly tested in the lab and in the field to validate performance in the areas of corrosion and dynamic wear resistance. Cylinders protected with Schrader Bellows's

Global Shield coating have demonstrated resistance to corrosion up to 8x longer than conventional coatings. Tests also confirm leak-free performance even after 1 million cycles and 2,000 hours of salt spray.

### Availability

- Rod diameters from ½" to 15"
- Rod lengths to 13 feet
- Standard thickness – 0.001"  
*Up to 0.020" available; corrosion protection increases as the thickness increases*
- Standard substrate – 1045/1050 carbon steel  
*Other substrates available*

### How to Order

Enter an 'S' in the Special Modifications field of the model number and specify Global Shield Piston Rod Coating. Unless otherwise specified, standard 0.001" thickness will be supplied.

For additional Global Shield information see Bulletin HY08-0896.

**⚠ PROP 65 WARNING** WARNING: This product can expose you to chemicals including **Lead and Lead Compounds** which are known to the State of California to cause cancer and birth defects or other reproductive harm. For more information go to [www.P65Warnings.ca.gov](http://www.P65Warnings.ca.gov)





## **Section F**

### **Engineering Data**

Push & Pull Forces	100-101
Cylinder Weights	103
Operating Fluids and Seals / Temperature Range	104
Fluids and Temperature Range / Pressure Ratings	105
Piston & Bushing Friction / Piston Orifice	106-107
Ports	108-109
Stroke Data / Mounting Groups	110
Stop Tubing	111
Piston Rod Selection Data	112-113
Cushioning	115-120
Cylinder Safety Guide .....	124-125
Offer of Sale .....	126

**⚠ PROP 65 WARNING** **WARNING:** This product can expose you to chemicals including **Lead and Lead Compounds** which are known to the State of California to cause cancer and birth defects or other reproductive harm. For more information go to [www.P65Warnings.ca.gov](http://www.P65Warnings.ca.gov)

**Push Forces**

**Theoretical Push Forces for Hydraulic Cylinders**

Cylinder Bore Ø	Piston Area (Sq. In.)	Cylinder Push Stroke Force in Pounds at Various Pressures						
		100	250	500	1000	1500	2000	3000
1.50	1.77	177	443	885	1770	2651	3540	5310
2.00	3.14	314	785	1570	3140	4712	6280	9420
2.50	4.91	491	1228	2455	4910	7363	9820	14730
3.25	8.30	830	2075	4150	8300	12444	16600	24900
4.00	12.57	1257	3143	6285	12570	18850	25140	37710
5.00	19.64	1964	4910	9820	19640	29453	39280	58920
6.00	28.27	2827	7068	14135	28270	42412	56540	84810
7.00	38.49	3849	9623	19245	38490	57727	76980	115470
8.00	50.27	5027	12568	25135	50270	75398	100540	150810
10.00	78.54	7854	19635	39270	78540	117810	157080	235620
12.00	113.10	11310	28275	56550	113100	169650	226200	339300
14.00	153.94	15394	38485	76970	153940	230910	307880	461820
16.00	201.06	20106	50265	100530	201060	301590	402120	603180
18.00	254.47	25447	63620	127230	254470	381700	508940	763410
20.00	314.16	31416	78540	157080	314160	471240	628320	942480

**General Formula**

The cylinder output forces are derived from the formula:

$$F = P \times A$$

Where F = Force in pounds.

P = Pressure at the cylinder in pounds per square inch, gauge.

A = Effective area of cylinder piston in square inches.

Custom Modifications

**⚠ PROP 65 WARNING** WARNING: This product can expose you to chemicals including **Lead and Lead Compounds** which are known to the State of California to cause cancer and birth defects or other reproductive harm. For more information go to [www.P65Warnings.ca.gov](http://www.P65Warnings.ca.gov)

**Theoretical Pull Forces for Hydraulic Cylinders**

Cylinder Bore Ø	Piston Rod Ø	Piston Rod Area (Sq. In.)	Cylinder Pull Force in Pounds at Various Pressures (psi)						
			100	250	500	1000	1500	2000	3000
1.50	0.625	0.307	146	365	730	1460	2190	2920	4380
	1.000	0.785	98	245	491	982	1473	1964	2946
2.00	1.000	0.785	236	589	1178	2355	3533	4710	7065
	1.375	1.48	166	414	828	1655	2483	3310	4965
2.50	1.000	0.785	413	1031	2063	4125	6188	8250	12375
	1.375	1.48	343	856	1713	3425	5138	6850	10275
	1.750	2.41	250	625	1250	2500	3750	5000	7500
3.25	1.375	1.48	682	1704	3408	6815	10223	13630	20445
	1.750	2.41	589	1473	2945	5890	8835	11780	17670
	2.000	3.14	516	1290	2580	5160	7740	10320	15480
4.00	1.750	2.41	1016	2540	5080	10160	15240	20320	30480
	2.000	3.14	943	2358	4715	9430	14145	18860	28290
	2.500	4.91	766	1915	3830	7660	11490	15320	22980
5.00	2.000	3.14	1650	4125	8250	16500	24750	33000	49500
	2.500	4.91	1473	3683	7365	14730	22095	29460	44190
	3.000	7.07	1257	3143	6285	12570	18855	25140	37710
	3.500	9.62	1002	2505	5010	10020	15030	20040	30060
6.00	2.500	4.91	2336	5840	11680	23360	35040	46720	70080
	3.000	7.07	2120	5300	10600	21200	31800	42400	63600
	3.500	9.62	1865	4663	9325	18650	27975	37300	55950
	4.000	12.57	1570	3925	7850	15700	23550	31400	47100
7.00	3.000	7.07	3142	7855	15710	31420	47130	62840	94260
	3.500	9.62	2887	7218	14435	28870	43305	57740	86610
	4.000	12.57	2592	6480	12960	25920	38880	51840	77760
	4.500	15.90	2259	5648	11295	22590	33885	45180	67770
	5.000	19.63	1886	4715	9430	18860	28290	37720	56580
8.00	3.500	9.62	4065	10163	20325	40650	60975	81300	121950
	4.000	12.57	3770	9425	18850	37700	56550	75400	113100
	4.500	15.90	3437	8593	17185	34370	51555	68740	103110
	5.000	19.63	3064	7660	15320	30640	45960	61280	91920
	5.500	23.76	2651	6628	13255	26510	39765	53020	79530
10.00	4.500	15.90	6264	15660	31320	62640	93960	125280	187920
	5.000	19.63	5891	14728	29455	58910	88365	117820	176730
	5.500	23.76	5478	13695	27390	54780	82170	109560	164340
	7.000	38.48	4006	10015	20030	40060	60090	80120	120180
12.00	5.500	23.76	8934	22335	44670	89340	134010	178680	268020
	7.000	38.48	7462	18655	37310	74620	111930	149240	223860
	8.000	50.26	6284	15710	31420	62840	94260	125680	188520
14.00	7.000	38.48	11546	28865	57730	115460	173190	230920	346380
	8.000	50.26	10368	25920	51840	103680	155520	207360	311040
	10.000	78.54	7540	18850	37700	75400	113100	150800	226200
16.00	8.000	50.26	15080	37700	75400	150800	226200	301600	452400
	9.000	63.62	13744	34360	68720	137440	206160	274880	412320
	10.000	78.54	12252	30630	61260	122520	183780	245040	367560
18.00	9.000	63.62	19085	47713	95425	190850	286275	381700	572550
	10.000	78.54	17593	43983	87965	175930	263895	351860	527790
20.00	10.000	78.54	23562	58905	117810	235620	353430	471240	706860



**⚠ PROP 65 WARNING** WARNING: This product can expose you to chemicals including **Lead and Lead Compounds** which are known to the State of California to cause cancer and birth defects or other reproductive harm. For more information go to [www.P65Warnings.ca.gov](http://www.P65Warnings.ca.gov)

**Notes**

Custom  
Modifications

 **PROP 65 WARNING** **WARNING:** This product can expose you to chemicals including **Lead and Lead Compounds** which are known to the State of California to cause cancer and birth defects or other reproductive harm. For more information go to [www.P65Warnings.ca.gov](http://www.P65Warnings.ca.gov)

**Cylinder Weights**

**Heavy Duty Hydraulic Cylinders  
Custom Modifications**

The weights shown below are for standard Series PH hydraulic cylinders equipped with various diameter piston rods. To determine the net weights of a cylinder, first select the proper basic weight for zero stroke, then calculate the weight of the cylinder stroke and add the result to the basic weight. For extra rod extension use

piston rod weights per inch shown in Table C. Weights of cylinders with intermediate rods may be estimated from table below by taking the difference between the piston rod weights per inch and adding it to the Code 1 weight for the cylinder bore size involved.

**Table A** Cylinder Weights, in pounds, for Series PH (7.00" & 8.00") hydraulic cylinders

Bore Ø	Rod Ø	Rod Code	Single Rod Cylinders Basic Weight Zero Stroke		Add Per Inch of Stroke	Double Rod Cylinders Basic Weight Zero Stroke		Add Per Inch of Stroke
			F, H, HB, J, JB, T, TB, TC, TD	BB, C, D, DB, DD, DE, HH, JJ, SB, SE		KF, KJ, KJB, KT, KTB, KTD	KC, KD, KDD, KDE, KJJ	
1.50	0.625	1	7.8	9.0	0.5	9.7	10.8	0.6
	1.000	2	8.4	9.3	0.6	9.1	10.7	0.8
2.00	1.000	1	11.6	13.2	0.8	14.6	16.8	1.0
	1.375	2	13.5	17.1	1.0	19.4	20.6	1.4
2.50	1.000	1	17.0	19.5	1.1	21.0	24.5	1.3
	1.750	2	22.5	25.5	1.5	27.0	30.0	2.2
3.25	1.375	1	32.0	41.0	1.8	43.0	52.0	2.2
	2.000	2	37.0	46.0	2.2	48.0	57.0	3.1
4.00	1.750	1	48.0	53.0	2.5	59.0	63.0	3.2
	2.500	2	52.0	58.0	3.2	92.0	97.0	4.6
5.00	2.000	1	76.0	82.0	3.4	96.0	102.0	4.8
	3.500	2	88.0	86.0	5.2	117.0	123.0	7.9
6.00	2.500	1	125.0	133.0	5.2	153.0	159.0	6.6
	4.000	2	133.0	140.0	7.3	182.0	190.0	10.9
7.00	3.000	1	233.0	242.0	6.7	320.0	339.0	8.7
	5.000	2	240.0	253.0	10.3	341.0	360.0	15.9
8.00	3.500	1	262.0	276.0	9.0	323.0	331.0	11.7
	5.500	2	300.0	309.0	13.0	390.0	411.0	19.7

**Table B** Cylinder Weights, in pounds, for Series PH large bore hydraulic cylinders

Bore Ø	Rod Ø	Rod Code	Single Rod Cylinders Basic Weight Zero Stroke					Double Rod Cylinders	
			D, DB	DD, JJ, HH	JB, HB	BB, C	Add Per Inch of Stroke	Basic Weight Zero Stroke Add to All Mounting Styles	Add Per Inch of Stroke
10.00	4.500	1	562	646	684	607	15	43	20
	5.000	3	574	656	695	619	16	50	21
	5.500	4	583	667	705	628	17	64	24
	7.000	2	620	704	742	665	21	101	32
12.00	5.500	1	924	1057	1136	1000	22	64	29
	7.000	3	961	1094	1173	1036	26	101	37
	8.000	2	1022	1155	1234	1097	29	162	43
14.00	7.000	1	1335	1520	1582	1485	28	101	39
	8.000	3	1396	1581	1643	1546	31	162	45
	10.000	2	1496	1681	1743	1646	39	262	61

Bore Ø	Rod Ø	Rod Code	Single Rod Cylinders Basic Weight Zero Stroke				Double Rod Cylinders	
			JJ, HH	JB, HB	BB	Add Per Inch of Stroke	Basic Weight Zero Stroke Add to All Mounting Styles	Add Per Inch of Stroke
16.00	8.000	1	2073	2257	2226	35	149	49
	9.000	3	2122	2305	2275	39	198	57
	10.000	4	2181	2364	2334	43	257	65
18.00	9.000	1	3165	3256	3330	45	198	63
	10.000	3	3224	3315	3390	50	257	72
20.00	10.000	1	4231	4406	4551	57	257	79

**Table C** Extra weight for longer than standard rod extensions can be calculated from the table below.

Rod Ø	Piston Rod Weight Per Inch	Rod Ø	Piston Rod Weight Per Inch	Rod Ø	Piston Rod Weight Per Inch
0.625	0.09	2.500	1.40	5.000	5.56
1.000	0.22	3.000	2.00	5.500	6.72
1.375	0.42	3.500	2.72	7.000	10.89
1.750	0.68	4.000	3.56	8.000	14.22
2.000	0.89	4.500	4.51	10.000	22.23

**⚠ PROP 65 WARNING** WARNING: This product can expose you to chemicals including **Lead and Lead Compounds** which are known to the State of California to cause cancer and birth defects or other reproductive harm. For more information go to [www.P65Warnings.ca.gov](http://www.P65Warnings.ca.gov)

**Operating Fluids and Temperature Range**

Fluid Power cylinders are designed for use with pressurized air, hydraulic oil and fire resistant fluids, in some cases special seals are required.

**Class 1 – Standard Seals**

Class 1 seals are intended for use with fluids such as: air, nitrogen, mineral base hydraulic oil or MIL-H-5606 within the temperature range of -10°F (-23°C) to +165°F (+74°C). Generally they are nitrile except for piston rod seals in hydraulic cylinders. However the individual seals may be nitrile (Buna-N) enhanced polyurethane, polymyte, PTFE or filled PTFE.

**Class 2 – Water Base Fluid Seals**

Generally class 2 seals are intended for use with water base fluids within the temperature of -10°F (-23°C) to +165°F (+74°C) except for High Water Content Fluids (HWCF) in which case Class 6 seals should be used. Typical water base fluids are: Water, Water-Glycol, Water-in-Oil Emulsion, Houghto-Safe 27, 620, 5040, Mobil Pyrogard D, Shell Iruis 905, Ucon Hydrolube J-4. These seals are nitrile.

**Class 3 – Ethylene Propylene (EPR) Seals**

Class 3 seals are intended for use with some Phosphate Ester Fluids between the temperatures of -10°F (-23°C) to +130°F (+54°C). Typical fluids compatible with EPR seals are Skydrol 500 and 700. EPR are Ethylene Propylene. Note: EPR seals are not compatible with mineral base hydraulic oil or greases. Even limited exposure to these fluids will cause severe swelling.

**Class 4 – Low Temperature Nitrile Seals**

Class 4 seals are intended for low temperature service with the same type of fluids as used with Class 1 seals within the temperature range of -50°F (-46°C) to +150°F (+66°C). Note: Certain fluids may react adversely with Class 4 seals compared to Class 1 seals.

**Class 5 – Fluorocarbon (FKM) Seals**

Class 5 seals are intended for elevated temperature service or for some Phosphate Ester Fluids such as Houghto-Safe 1010, 1055, 1120; Fyrquel 150, 220, 300, 350; Mobile Pyrogard 42, 43, 53, and 55. However, they are not compatible with Phosphate Ester Fluids such as Skydrols. Class 5 seals can operate with a temperature range of -10°F (-23°C) to +300°F (+149°C). For temperatures above +250°F (+121°C) the cylinder must be manufactured with non-studded piston rod and thread and a pinned piston to rod connection.

**Class E – Fluorocarbon piston rod bushing seals only**

Intended for applications where only the rod bushing is exposed to fluids or temperatures needing fluorocarbon compatibility.

**Class 6 – HWCF Seals**

Class 6 seals are intended for High Water Content Fluids (HWCF) such as Houghton, Hydrolubric 120B and Sonsol Lubrizol within the

temperature range of +40°F (+4°C) to +120°F (+49°C). Class 6 seals are special nitrile compound dynamic seals. Because of the viscosity of these fluids, cylinders specified with class 6 seals, will also be modified to have straight cushions.

**Class 8 – High Temperature Seals**

Class 8 seals consist of filled PTFE piston seal, rod seals and wiperseal. They are intended for high temperature applications, to 400° F (204° C), where longer seal life and improved high temperature sealing performance is required. Minimum operating temperature is -15°F (-26°C). Body and bushing o-ring seals will be fluorocarbon. Fluid resistance is comparable to Class 5. Cylinders incorporating Class 8 Seals will not have studded piston rods.

**Class N – Class 8 piston rod bushing seals only – all other seals are fluorocarbon**

Intended for applications where only the rod bushing is exposed to fluids or temperatures needing filled PTFE seal compatibility.

**Warning ⚠**

The piston rod stud and the piston rod to piston threaded connections are secured with an anaerobic adhesive which is temperature sensitive. Cylinders are assembled with anaerobic adhesive having a maximum temperature rating of +250°F (+121°C). Cylinders specified with all other seal compounds (built before 1997) were assembled with anaerobic adhesive having a maximum operating temperature rating +165°F (+74°C). These temperature limitations are necessary to prevent the possible loosening of the threaded connections. Cylinders originally manufactured (before 1997) with class 1 seals (Nitrile) that will be exposed to ambient temperatures above +165°F (+74°C) must be modified for higher temperature service. Contact the factory immediately and arrange for the piston to rod and the stud to piston rod connections to be properly re-assembled to withstand the higher temperature service.

**Water Service**

Series PH cylinders can be modified to make them more suitable for use with water as the operating medium. The modifications include chrome-plated cylinder bore; electroless nickel-plated head, cap and piston; chrome-plated 17-4 stainless steel piston rod; chrome plated cushion sleeve or cushion spear. Water and high water base fluid operated cylinders are best used on short stroke applications or where high pressure is applied only to clamp the load.

**Warranty**

Parker Hannifin will warrant cylinders modified for water or high water content fluid service to be free of defects in materials or workmanship, but cannot accept responsibility to premature failure due to excessive wear due to lack of lubricity or where failure is caused by corrosion, electrolysis or mineral deposits within the cylinder.

**Seal Materials & Piston Seal Availability by Seal Class**

Seal Code (Class)	Description	Bushings Codes A, H & K			Piston Wear Rings	Piston Seal Material & Availability by Type				Piston Seal Energizer <sup>1</sup>	Piston Joint O-Ring	Body End Seals	Seal Back-Up Washer (if required)
		Rod Wiper-seal	Rod Seal	Bushing O-Ring		HP Urethane	KP Filled PTFE	RP Thermo-plastic	WP Filled PTFE				
1	Standard Seals	Urethane	Urethane	Urethane	WearGard™	Yes	Yes	Yes	Yes	Nitrile	Urethane	Urethane	PTFE
2	Water Base Fluid Seals	Nitrile	Nitrile	Nitrile	Polyester Resin/Fabric	No	Yes	Yes	Yes	Nitrile	Nitrile	Nitrile	PTFE
3	EPR Seals	EPR	EPR	EPR	WearGard™	No	Yes	Yes	Yes	EPR	EPR	EPR	PTFE
4	Low Temp. Nitrile Seals	Nitrile	Nitrile	Nitrile	WearGard™	Yes	Yes	Yes	No	Nitrile	Nitrile	Nitrile	PTFE
5	Fluorocarbon Seals	FKM	FKM	FKM	WearGard™	No	Yes	Yes	Yes	FKM	FKM	FKM	PTFE
6	HWCF Seals	Nitrile	Nitrile	Nitrile	Polyester Resin/Fabric	No	Yes	Yes	Yes	Nitrile	Nitrile	Nitrile	PTFE
8	High Temp. Seals	Filled PTFE	Filled PTFE	FKM	HT Resin/Aramid	No	Yes	No	No	FKM	FKM	FKM	PTFE
E	Fluorocarbon Bushing Seals	FKM	FKM	FKM	WearGard™	Yes	Yes	Yes	Yes	FKM	FKM	FKM	PTFE
N	High Temp. Bushing Seals	Filled PTFE	Filled PTFE	FKM	HT Resin/Aramid	Yes	Yes	Yes	Yes	FKM	FKM	FKM	PTFE

<sup>1</sup> Includes material of redundant quad ring seal for Schrader Bellows WP Mixed Media Seal

**⚠ PROP 65 WARNING** WARNING: This product can expose you to chemicals including **Lead and Lead Compounds** which are known to the State of California to cause cancer and birth defects or other reproductive harm. For more information go to [www.P65Warnings.ca.gov](http://www.P65Warnings.ca.gov)

Custom Modifications

**Fluids and Temperature Range**

Class No.	Typical Fluids	Temperature Range
1 (Standard) (Nitrile Polyurethane)	Air, Nitrogen Hydraulic Oil, Mil-H-5606 Oil	-10°F (-23°C) to +165°F (+74°C)
2 Optional Water Base Fluid Seal	Water, Water-Glycol, HWCF — See Class 6 below. Water-in-Oil Emulsion Houghto-Safe, 271, 620, 5040. Mobil Pyrogard D, Shell IruS 905. Ucon Hydrolube J-4	-10°F (-23°C) to +165°F (+74°C)
3 Special (EPR) (at extra cost)	Some Phosphate Ester Fluids Skydrol 500, 7000	-10°F (-23°C) to +130°F (+54°C)
Note: (EPR) seals are not compatible with Hydraulic Oil		
4 Special (Nitrile) (at extra cost)	Low Temperature Air or Hydraulic Oil	-50°F (-46°C) to +150°F (+66°C)
5 Optional (at extra cost) (Fluorocarbon Seals)	High Temperature Houghto-Safe 1010, 1055, 1120 Fyrquel 150, 220, 300, 550 Mobil Pyrogard 42,43,53,55	See paragraph on Fluorocarbon seals for recommended temperature range.
Note: Fluorocarbon seals are not suitable for use with Skydrol fluid, but can be used with hydraulic oil if desired.		
6 Optional (HWCF) (at extra cost)	Houghton, Hydrolubric 120B Sonsol Lubrizol, for other HWCF — consult factory.	+40°F (+4°C) to +120°F (+49°C)
8 Optional (at extra cost) Energized PTFE	See Class 5 Seals	-15°F (-26°C) to +400°F (+204°C)

**Application Data**

The proper application of a fluid power cylinder requires consideration of the operating pressure, the fluid medium, the mounting style, the length of stroke, the type of piston rod connection to the load, thrust or

tension loading on the rod, mounting attitude, the speed of stroke, and how the load in motion will be stopped. Information given here provides pressure rating data for hydraulic cylinders.

**Pressure Ratings**

Standard operating fluid — clean, filtered hydraulic oil. Pressure ratings for heavy-duty hydraulic cylinders are shown in the table.

Series PH hydraulic cylinders are recommended for pressures to 3000 psi for heavy-duty service with hydraulic oil. The 4:1 design factor ratings shown are based on tensile strength of material and are for standard rod diameter only. The rating is conservative for continuous severe applications. Design factors at other pressures can be calculated from this rating. In addition, mounting styles, stroke, etc., should be considered because of the limiting effect they may have on these ratings.

**Series PH Hydraulic Cylinders  
Maximum Pressure Ratings**

Bore Ø	Rod Ø	4:1 <sup>1</sup> Design Factor (Tensile) (psi)	Heavy-Duty Service (psi)
1.50	0.625	2530	3000
2.00	1.000	2950	3000
2.50	1.000	2340	3000
3.25	1.375	2250	3000
4.00	1.750	2130	3000
5.00	2.000	2170	3000
6.00	2.500	2270	3000
7.00	3.000	2030	3000
8.00	3.500	2040	3000
10.00	4.500	2720	3000
12.00	5.500	2580	3000
14.00	7.000	2320	3000
16.00	8.000	2750	3000
18.00	9.000	2900	3000
20.00	10.000	2640	3000

<sup>1</sup> Applies to all mountings except Styles J, JB and H.

**⚠ PROP 65 WARNING** WARNING: This product can expose you to chemicals including **Lead and Lead Compounds** which are known to the State of California to cause cancer and birth defects or other reproductive harm. For more information go to [www.P65Warnings.ca.gov](http://www.P65Warnings.ca.gov)



**Piston Friction**

Schrader Bellows's new universal piston design provides not only superior sealing and wear performance, but also conserves operating energy with reduced running friction when compared to traditional sealing technologies. Running friction test results for the most

popular seal configurations, HP Polyurethane Piston Seal and KP filled PTFE Piston Seal in 2.00", 4.00", 6.00" and 8.00" bores are shown in graphs below. Friction for intermediate bore sizes can be estimated using curves for bore sizes tested.

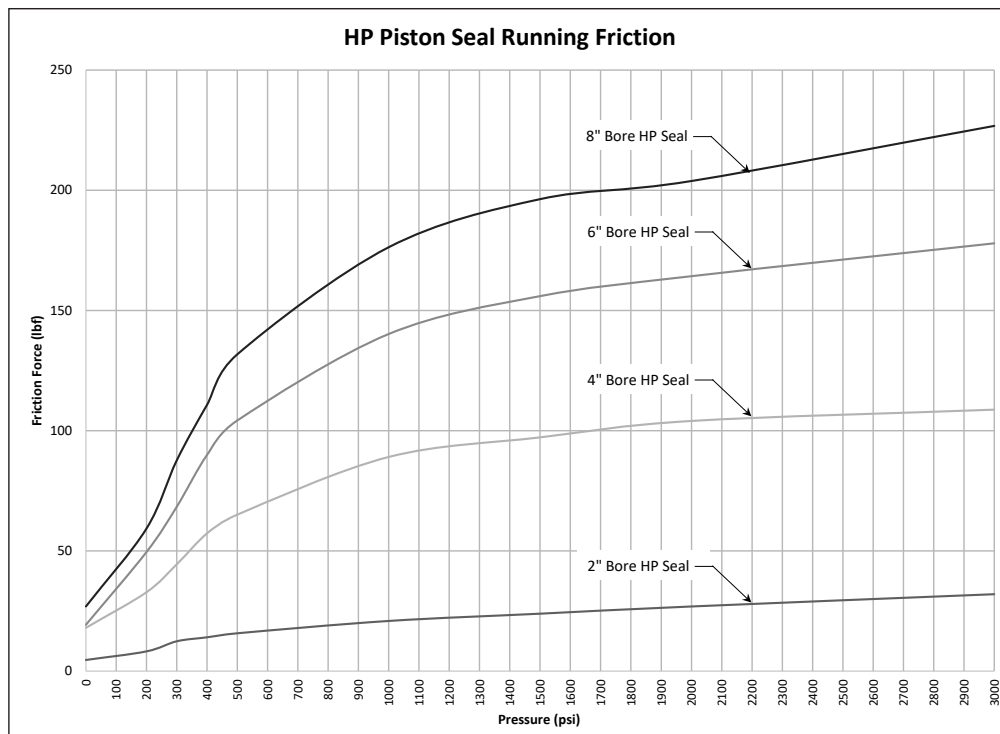

**Schrader Bellows  
HP Polyurethane  
Piston Seal**

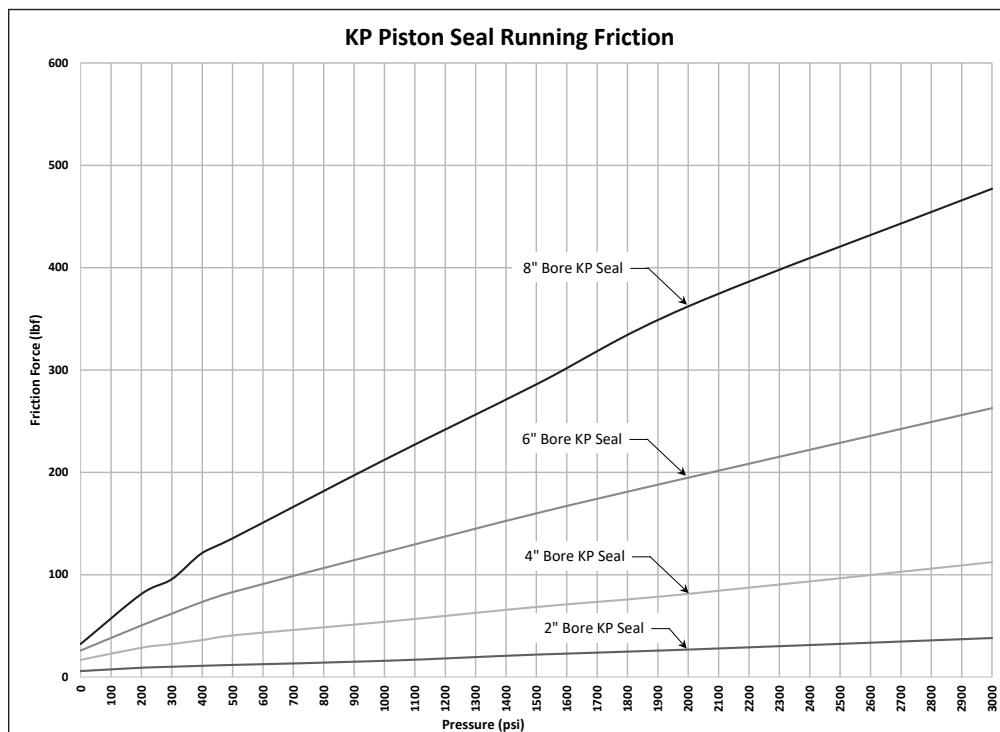
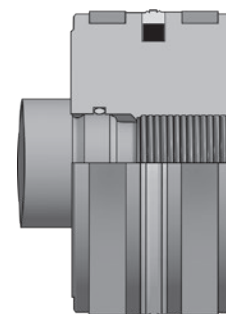

**Schrader Bellows  
KP Filled PTFE  
Piston Seal**

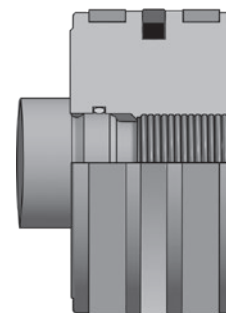

Custom Modifications

**⚠ PROP 65 WARNING** WARNING: This product can expose you to chemicals including **Lead and Lead Compounds** which are known to the State of California to cause cancer and birth defects or other reproductive harm. For more information go to [www.P65Warnings.ca.gov](http://www.P65Warnings.ca.gov)



**Bushing Friction**

Bushing friction is also a factor in cylinder operating efficiency and combined with piston seal friction will yield an overall cylinder running friction value. Running friction test results for PH (Tri-Lip) and Low Friction bushings in

1.000", 1.750", 2.500" and 5.000" piston rod diameters are shown in the graphs below. Friction for intermediate rod diameters can be estimated using curves for bore sizes tested.

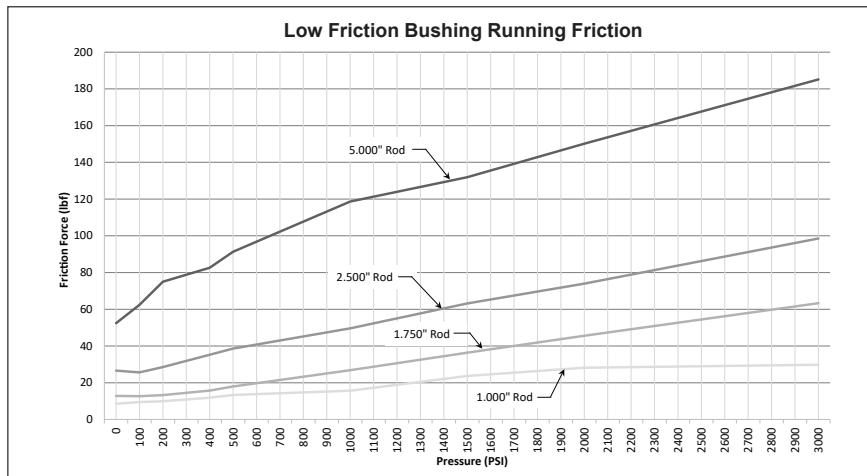
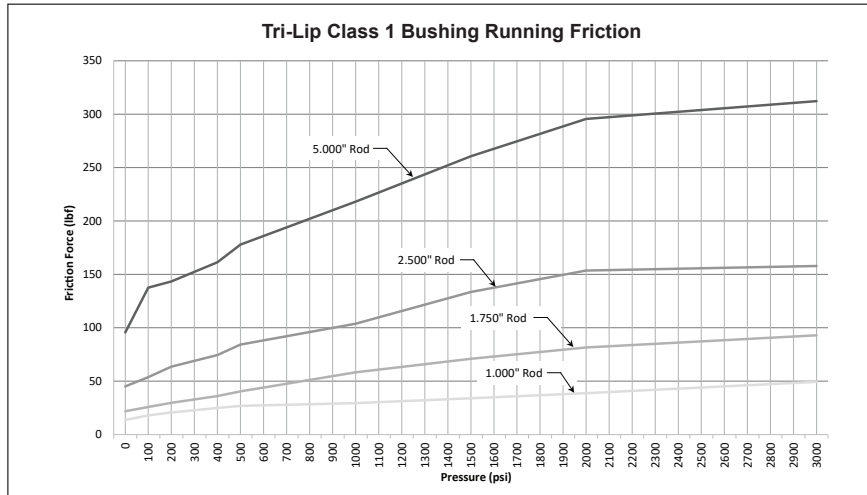

**Piston Orifice**

Schrader Bellows's RP Thermoplastic piston seal is fully extrusion resistant and the choice for applications formerly served by cast iron rings. For some applications, cast iron rings are selected because of the inherent piston bypass. Where bypass is required for the RP seal (or any other universal piston seal style), a piston orifice option is available. There are three orifice diameters to choose from, 0.016", 0.024" and 0.032". Flow charts at right detail the bypass flow at various pressures for each orifice. Specify the orifice by placing an 'S' in the Special Modification field of the model number and describe the orifice as in the following example: S = 0.024" Piston Orifice (insert desired orifice dia). Piston orifice not available in bores 1.50", 2.00" and 2.50" with rod codes 2 & 3.

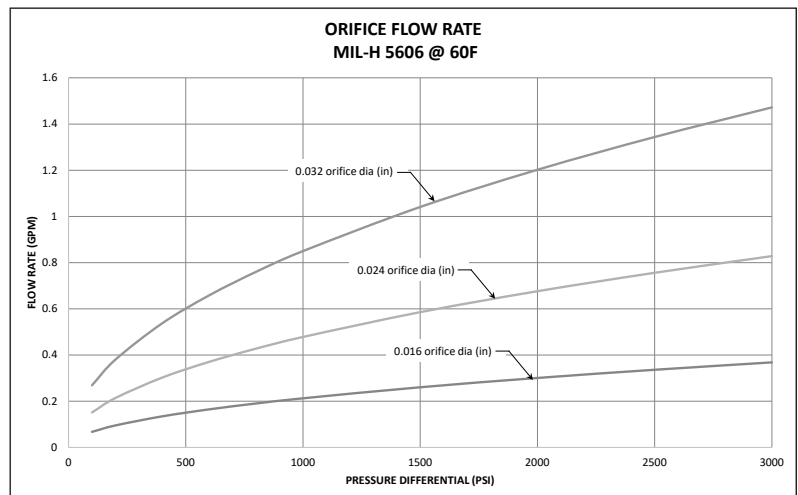

**⚠ PROP 65 WARNING** WARNING: This product can expose you to chemicals including **Lead and Lead Compounds** which are known to the State of California to cause cancer and birth defects or other reproductive harm. For more information go to [www.P65Warnings.ca.gov](http://www.P65Warnings.ca.gov)

**Ports**

**Ports**

Series PH cylinders can be supplied with SAE straight O-ring ports or NPTF pipe thread ports. If specified on your order, extra ports can be provided on the sides of heads or caps that are not occupied by mountings or cushion valve.

Standard port location is position 1 as shown on line drawings in product catalog and Figure 1 below. Cushion adjustment needle and check valves are at positions 2 and 4 (or 3), depending on mounting style. Heads or caps which do not have an integral mounting can be rotated and assembled with ports at 90° or 180° from standard position. Mounting styles on which head or cap can be rotated at no extra charge are shown in Table A below. To order, specify by position number. In such assemblies the cushion adjustment needle and check valve rotate accordingly since their relationship with port position does not change.

**Figure 1**

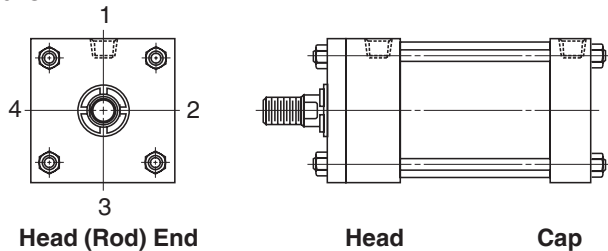

**Table A**

Mounting Style	Port Position Available	
	Head End	Cap End
TB, TC, TD, J, H, JB, HB, DD, DE	1, 2, 3 or 4	1, 2, 3 or 4
HH, DB, BB, SB, SE	1, 2, 3 or 4	1 or 3
JJ, D	1 or 3	1, 2, 3 or 4
C, F	1	1

Ports can be supplied at positions other than those shown in Table A at an extra charge. To order, specify port position as shown in Figure 1.

**Straight Thread Ports**

The SAE straight thread O-ring port is recommended for hydraulic applications. Schrader Bellows will furnish this port configuration at positions shown in Table A. This port can also be provided at positions other than those shown in Table A at an extra charge. SAE port size numbers are listed next to the NPTF pipe thread counterparts for each bore size in the respective product catalogs. Size number, tube O.D., and port thread size for SAE ports are listed in Table B.

**Table D – Standard Port Sizes**

Bore Ø	T SAE	U NPTF	P SAE Code 61 Flange	Y ISO 6149	B BSPT R BSPP	G Metric
1.50	10	1/2	N/A	M22 x 1.5	1/2	M22 x 1.5
2.00	10	1/2	N/A	M22 x 1.5	1/2	M22 x 1.5
2.50	10	1/2	1/2 <sup>1</sup>	M22 x 1.5	1/2	M22 x 1.5
3.25	12	3/4	3/4	M27 x 2	3/4	M27 x 2
4.00	12	3/4	3/4	M27 x 2	3/4	M27 x 2
5.00	12	3/4	3/4	M27 x 2	3/4	M27 x 2
6.00	16	1	1	M33 x 2	1	M33 x 2

<sup>1</sup>Available with 1.000 inch rod diameter only.

**Table B — SAE Straight Thread O-Ring Ports**

Size No.	Tube O.D. (In.)	Thread Size	Size No.	Tube O.D. (In.)	Thread Size
2	0.13	5/16 - 24	12	0.75	1 1/16 - 12
3	0.19	3/8 - 24	—	—	—
4	0.25	7/16 - 20	16	1.00	1 5/16 - 12
5	0.31	1/2 - 20	20	1.25	1 5/8 - 12
6	0.38	9/16 - 18	24	1.50	1 7/8 - 12
8	0.50	3/4 - 16	32	2.00	2 1/2 - 12
10	0.63	7/8 - 14	—	—	—

**Note:** For the pressure ratings of individual connectors, contact your connector supplier. Hydraulic cylinders applied with meter out or deceleration circuits are subject to intensified pressure at the cylinder piston rod end. The rod end pressure is approximately equal to:

$$\frac{\text{Effective Cap End Piston Area}}{\text{Effective Rod End Piston Area}} \times \text{Operating Pressure}$$

**International Ports**

Other port configurations to meet international requirements are available at extra cost. Schrader Bellows Series PH cylinders can be supplied, on request, with British standard taper port (BSPT). Such port has a taper of 1 in 16 measured on the diameter (1/16" per inch). The thread form is Whitworth System, and size and number of threads per inch are as follows:

**Table C — British Standard Pipe Threads**

Nominal Pipe Size	No. Threads Per Inch	Pipe O.D.
1/8	28	0.383
1/4	19	0.518
3/8	19	0.656
1/2	14	0.825
3/4	14	1.041
1	11	1.309
1 1/4	11	1.650
1 1/2	11	1.882
2	11	2.347

British standard parallel internal threads are designated as BSPP and have the same thread form and number of threads per inch as the BSPT type and can be supplied, on request, at extra cost. Unless otherwise specified, the BSPP or BSPT port size supplied will be the same nominal pipe size as the NPTF port for a given bore size cylinder.

Metric ports can also be supplied to order at extra cost. See table below for standard port size for each bore.

**⚠ PROP 65 WARNING** WARNING: This product can expose you to chemicals including **Lead and Lead Compounds** which are known to the State of California to cause cancer and birth defects or other reproductive harm. For more information go to [www.P65Warnings.ca.gov](http://www.P65Warnings.ca.gov)

Custom Modifications

Ports

Overize Ports

Overize NPTF or SAE straight thread ports can be provided, at an extra charge. For ports one size larger than standard, welded port bosses which protrude from the side of the head or cap are supplied. For dimensions, see drawings and tables below. Series PH cylinders equipped with cushions at the cylinder cap end can sustain damage to the cushion check valve (cushion bushing) if excessive oil flow enters the cylinder from the cap end port. Cylinders which are equipped with cap end cushions and ordered with one size overize ports having hydraulic fluid velocity exceeding 25 ft./sec. in the line entering the cap end of the cylinder should be ordered with a "solid cushion" at cap end. All cylinders ordered with

double overize ports should always be ordered with a "solid cushion" at cap end.

Cylinders which are connected to a meter out flow control with flow entering the cap end of a cylinder provided by an accumulator may also experience damage to the cushion bushing due to high instantaneous fluid flows. This condition can be eliminated by using a meter in flow control or "solid cushions" at cap end.

Overize NPTF Port Boss Dimensions

Bore Ø	EE (NPTF)	A Ø	B	C	D	P
1.50	3/4	1.38	1.00	0.75	0.78	2.91
2.00	3/4	1.38	1.00	0.75	0.78	2.91
2.50	3/4	1.38	1.00	0.75	0.78	3.03
3.25	1	1.75	1.19	0.91	0.88	3.53
4.00	1	1.75	1.19	0.91	0.88	3.78
5.00	1	1.75	1.19	0.91	0.88	4.28
6.00	1 1/4	2.25	1.31	1.13	1.13	5.13
7.00	1 1/2	2.50	1.56	1.38	1.38	5.75
8.00	2	3.00	1.69	1.50	1.50	6.50

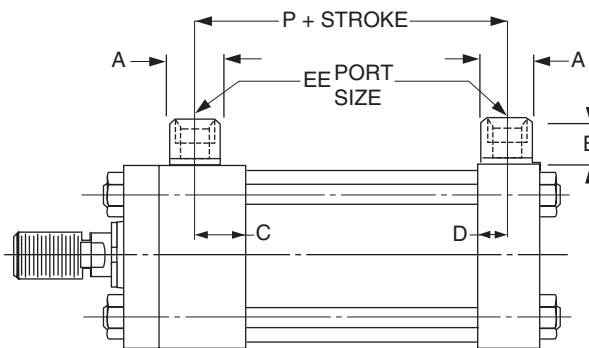

Overize SAE Straight Thread Port Boss Dimensions

Bore Ø	EE (SAE)	A Ø	B	C	D	P	
1.50	12 <sup>1</sup>	12	1.38	1.00	0.81	0.78	2.97
2.00	12 <sup>1</sup>	12	1.38	1.00	0.81	0.78	2.97
2.50	12 <sup>2</sup>	12 <sup>3</sup>	1.38	1.00	0.81	0.81	3.13
3.25	16	16	1.75	1.19	0.91	0.91	3.56
4.00	16	16	1.75	1.19	0.91	0.91	3.81
5.00	16	16	1.75	1.19	0.91	0.91	4.31
6.00	20 <sup>2</sup>	20 <sup>2</sup>	-	-	1.13	1.17	5.19
7.00	24 <sup>2</sup>	24 <sup>2</sup>	-	-	-	-	5.63
8.00	N/A	N/A	-	-	-	-	6.38

<sup>1</sup> Port tapped directly in head with code 1 rod these bores.

<sup>2</sup> Port tapped directly in head (all rod codes) and cap these bores.

<sup>3</sup> Port tapped directly in cap this bore.

Flange Ports (Code 61, 3000 psi) SAE 4 Bolt Flange Ports

Bore Ø	Rod No.	SAE Dash No.	A Ø	AA	GG	P	Q	W	X	Y	Z
2.50 <sup>4,5</sup>	1	8	.50	.81	.69	3.00	1.50	.75	.34	2.38	5/16 - 18
3.25 <sup>4</sup>	1	12	.75	.75	.87	3.50	1.87	.94	.44	2.75	3/8 - 16
	2									3.13	
	3									3.00	
4.00 <sup>4</sup>	1	12	.75	.75	.87	3.75	1.87	.94	.44	3.00	3/8 - 16
	2									3.38	
	3									3.13	
5.00 <sup>4</sup>	1	12	.75	.75	.87	4.25	1.87	.94	.44	3.13	3/8 - 16
	2									3.38	
	3									3.38	
	4									3.38	
6.00	All	16	1.00	.87	1.03	4.87	2.06	1.03	.52	3.50	3/8 - 16
7.00	All	20	1.25	1.00	1.19	5.50	2.31	1.16	.59	3.75	7/16 - 14
8.00	All	24	1.50	1.06	1.41	6.25	2.75	1.37	.70	3.88	1/2 - 13

<sup>4</sup> 2.50", 3.25", 4.00" & 5.00" bores cap-flange port not available on Style HB. Style H not available at position 2 or 4. Port flange overhangs cap on Style HH. <sup>5</sup> 2.50" bore head flange port available with 1.000" rod only.

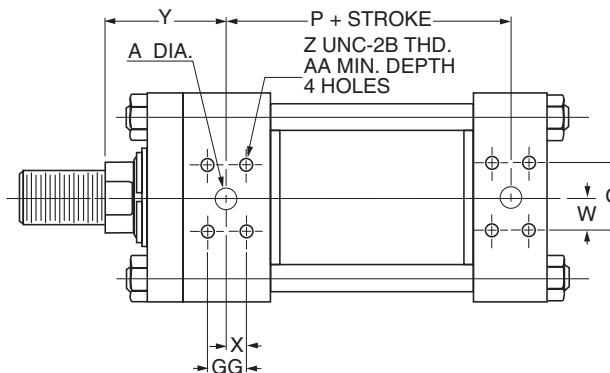

**⚠ PROP 65 WARNING** WARNING: This product can expose you to chemicals including **Lead and Lead Compounds** which are known to the State of California to cause cancer and birth defects or other reproductive harm. For more information go to [www.P65Warnings.ca.gov](http://www.P65Warnings.ca.gov)

**Stroke Data**

Schrader Bellows cylinders are available in any practical stroke length. The following information should prove helpful to you in selecting the proper stroke for your cylinder application.

**Stroke Tolerances**

Stroke length tolerances are required due to buildup of tolerances of piston, head, cap and cylinder tube. Standard production of stroke tolerances run +.031" to

-.015" up to 20" stroke, +.031" to -.020" for 21" to 60" and +.031" to -.031" for greater than 60" stroke. For closer tolerances on stroke length, it is necessary to specify the required tolerance plus the pressure and temperature at which the cylinder will operate. Stroke tolerances smaller than .015" are not generally practical due to elasticity of cylinders. If machine design requires such close tolerances, use of a stroke adjuster may achieve the desired result.

**Mounting Groups**

Standard mountings for fluid power cylinders fall into three basic groups. The groups can be summarized as follows:

**Group 1** Straight Line Force Transfer with fixed mounts which absorb force on cylinder centerline.

**Group 2** Pivot Force Transfer. Pivot mountings permit a cylinder to change its alignment in one plane.

**Group 3** Straight Line Force Transfer with fixed mounts which do not absorb force on cylinder centerline.

Because a cylinder's mounting directly affects the maximum pressure at which the cylinder can be used, the chart below should be helpful in selection of the proper mounting combination for your application. Stroke length, piston rod connection to load, extra piston rod length over standard, etc., should be considered for thrust loads. Alloy steel mounting bolts are recommended for all mounting styles, and thrust keys are recommended for Styles C and F.

**Double Rod End Cylinders**

The piston connection to rod #1 (without 'V' notch) of 1.50"-8.00" bore double rod end heavy duty hydraulic cylinders is pre-stressed for maximum fatigue life. For this reason the load should always be attached to the rod without 'V' notch. Extension rod #2 with 'V' notch is threaded to rod #1 and is recommended for non-load bearing attachment only.

For thrust (compression) load applications where the mounting style end of a double rod end cylinder is opposite the rod connected to the load it should be specified as a cap mounting style. For example, a head trunnion mounting style opposite the rod connected to the load should be specified as DB. This will ensure that the rod end without 'V' notch will be oriented opposite the head trunnion end. See the table below for guidance in selecting mounting styles that fit this criteria.

**Double Rod End Mounting Styles**

Mounting Styles for Single Rod Models	Mounting Styles for Corresponding Double Rod Models with the Load Connected To Rod Opposite Cylinder Mounting End
TB	KTC
J	KH
JB	KHB
JJ	KHH
D	KDB

**Double Rod Cylinder  
Style K**

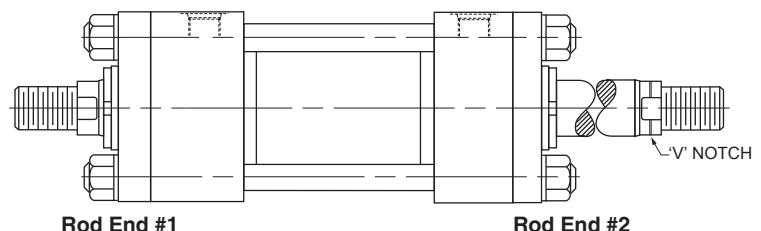

**Group 1 FIXED MOUNTS** which absorb force on cylinder centerline.

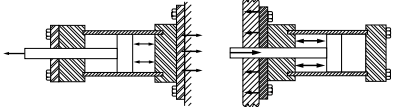
<b>Heavy-Duty Service</b> For Thrust Loads For Tension Loads	 Styles HB, HH, TC Styles JB, JJ, TB
<b>Medium-Duty Service</b> For Thrust Loads For Tension Loads	Styles H, HB Styles J, JB
<b>Light-Duty Service</b> For Thrust Loads For Tension Loads	Style H Style J

**Group 2 PIVOT MOUNTS** which absorb force on cylinder centerline.

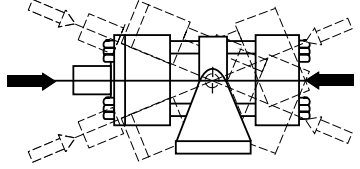
<b>Heavy-Duty Service</b> For Thrust Loads For Tension Loads	 Styles DD, D, DE, SE Styles BB, DD, D, DB, DE, SE
<b>Medium-Duty Service</b> For Thrust Loads For Tension Loads	Styles BB, SB Styles BB, SB

**Group 3 FIXED MOUNTS** which do not absorb force on the centerline.

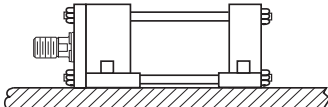
<b>Heavy-Duty Service</b> For Thrust Loads For Tension Loads	 Styles C, CP Styles C, CP
<b>Medium-Duty Service</b> For Thrust Loads For Tension Loads	Styles F, FP Styles F, FP

**⚠ PROP 65 WARNING** WARNING: This product can expose you to chemicals including **Lead and Lead Compounds** which are known to the State of California to cause cancer and birth defects or other reproductive harm. For more information go to [www.P65Warnings.ca.gov](http://www.P65Warnings.ca.gov)

Custom Modifications

## Stop Tubing

### Stop Tubing

Stop tube is recommended to lengthen the distance between the rod bearing and piston bearing to reduce bearing loads on long push stroke cylinders when the cylinder is fully extended. This is especially true of horizontally mounted cylinders. As part of the piston assembly and positioned between the piston and head, a stop tube restricts the extended position of the rod using the increased distance to achieve additional stability.

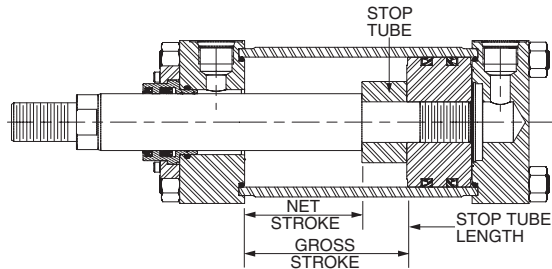

Use the following steps to determine the need for stop tube and, if required, how long it should be.

1. Examine the groups of cylinder illustrations below and determine which mounting and rod guiding group type match the required cylinder application.

#### Stop Tube Length vs Basic Length (L)

Pivot Mounts (BB, D, DB, DD, DE, SB and SE)		Fixed Mounts (C, F, H, HB, HH, J, JB, JJ, TB, TC, TD)						
Pivoted and Rigidly Guided Rod End		Fixed & Rigidly Guided Rod End		Pivoted & Rigidly Guided Rod End		Unguided Rod End		
Basic Length (L)	Stop Tube Length	Basic Length (L)	Stop Tube Length	Basic Length (L)	Stop Tube Length	Basic Length (L)	Stop Tube Length	
0 - 40	0	0 - 80	0	0 - 57	0	0 - 20	0	
41 - 50	1	81 - 100	1	58 - 71	1	21 - 25	1	
51 - 60	2	101 - 120	2	72 - 86	2	26 - 30	2	
61 - 70	3	121 - 140	3	87 - 100	3	31 - 35	3	
71 - 80	4	141 - 160	4	101 - 114	4	36 - 40	4	
81 - 90	5	161 - 180	5	115 - 129	5	41 - 45	5	
91 - 100	6	181 - 200	6	130 - 143	6	46 - 50	6	
101 - 110	7	201 - 220	7	144 - 157	7	51 - 55	7	
111 - 120	8	221 - 240	8	158 - 171	8	56 - 60	8	
121 - 130	9	241 - 260	9	172 - 186	9	61 - 65	9	
131 - 140	10	261 - 280	10	187 - 200	10	66 - 70	10	
141 - 150	11	281 - 300	11	201 - 214	11	71 - 75	11	
151 - 160	12	Consult Factory		215 - 229	12	76 - 80	12	
161 - 170	13			230 - 243	13	81 - 85	13	
171 - 180	14			244 - 257	14	86 - 90	14	
181 - 190	15			258 - 271	15	91 - 95	15	
191 - 200	16			272 - 286	16	96 - 100	16	
201 - 210	17			287 - 300	17	101 - 105	17	
211 - 220	18					106 - 110	18	
221 - 230	19					111 - 115	19	
231 - 240	20					116 - 120	20	
241 - 250	21					121 - 125	21	
251 - 260	22					126 - 130	22	
261 - 270	23					131 - 135	23	
271 - 280	24					136 - 140	24	
281 - 290	25					141 - 145	25	
291 - 300	26					146 - 150	26	
Consult Factory							Consult Factory	

## Heavy Duty Hydraulic Cylinders Custom Modifications

2. Establish the Basic Length (L), with the piston rod fully extended, for the selected illustration by using the dimensional tables on previous pages of this catalog. For pivot mounted cylinders, the pin-to-pin dimension with the piston rod fully extended must be used. Regardless of mounting style, be sure to include any extended piston rod length beyond the catalog standard.
3. In the Stop Tube Table select the column for the appropriate mounting style and rod end guiding type. In the Basic Length (L) column, find the row with the range that includes the value calculated in Step 2. The next respective column to the right has the required length of stop tube.

**Note:** Mounting Styles BB, DB, H, HB, HH, SB and SE are mounted horizontally should also be checked for turning moments and loads between the rod bearing and piston to ensure they are not excessive. Weight of oil must be included in determining bearing loads.

When specifying cylinders with stop tube be sure to call out the net stroke and the length of the stop tube. Machine design can be continued without delay by laying in a cylinder equivalent in length to the NET STROKE PLUS STOP TUBE LENGTH, which is referred to as GROSS STROKE.

#### Cylinder Mounting and Rod Guiding Groups

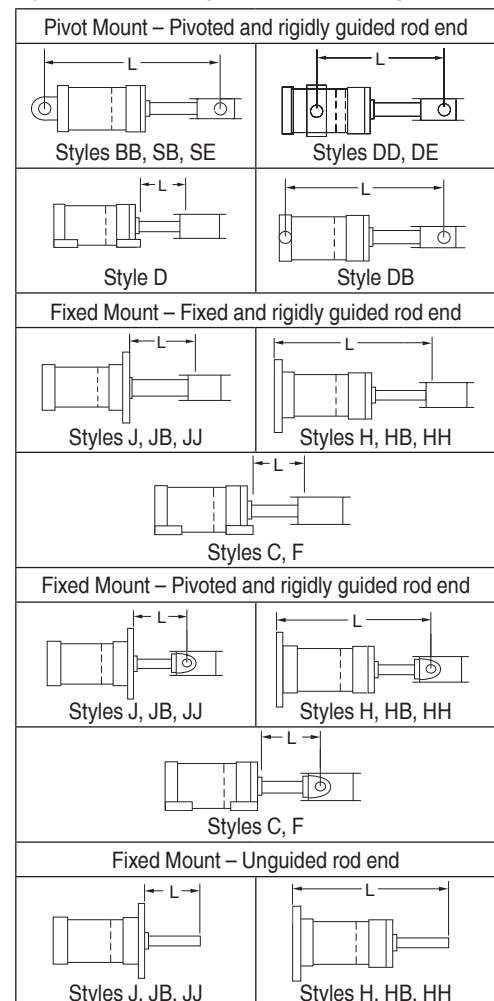

**⚠ PROP 65 WARNING** **WARNING:** This product can expose you to chemicals including **Lead and Lead Compounds** which are known to the State of California to cause cancer and birth defects or other reproductive harm. For more information go to [www.P65Warnings.ca.gov](http://www.P65Warnings.ca.gov)





**Piston Rod Selection Data**

**Maximum Basic Lengths (L<sub>A</sub>) (all dimensions in inches)**

Bore Ø	Rod Ø	Rear Pivot Mounts (BB, SB <sup>1</sup> , SE, DB)						Front and Intermediate Pivot Mounts (D, DD, DE)					
		Pivoted & Rigidly Guided Rod End Max. Allowable Basic Length (L <sub>A</sub> ) at psi:						Pivoted & Rigidly Guided Rod End Max. Allowable Basic Length (L <sub>A</sub> ) at psi:					
		500	1000	1500	2000	2500	3000	500	1000	1500	2000	2500	3000
1.50	0.625	35	25	20	18	16	14	25	18	14	13	11	10
	1.000	85	60	49	42	38	35	64	45	37	32	29	26
2.00	1.000	66	47	38	33	29	27	48	34	28	24	22	20
	1.375	116	82	67	58	52	47	91	64	53	45	41	37
2.50	1.000	54	38	31	27	24	22	38	27	22	19	17	16
	1.375	99	70	57	49	44	40	73	51	42	36	33	30
	1.750	151	106	87	75	67	61	118	83	68	59	53	48
3.25	1.375	78	55	45	39	35	32	56	40	32	28	25	23
	1.750	123	87	71	62	55	50	91	64	52	45	41	37
	2.000	157	111	90	78	70	64	118	84	68	59	53	48
4.00	1.750	102	72	59	51	45	41	74	52	43	37	33	30
	2.000	131	92	75	65	58	53	96	68	56	48	43	39
	2.500	194	137	112	97	87	79	150	106	87	75	67	61
5.00	2.000	107	76	62	53	48	44	77	54	44	38	34	31
	2.500	163	115	94	82	73	67	120	85	69	60	54	49
	3.000	226	160	130	113	101	92	173	122	100	87	77	71
	3.500	289	204	167	145	129	118	236	167	136	118	105	96
6.00	2.500	139	98	80	70	62	57	100	71	58	50	45	41
	3.000	197	139	114	98	88	80	144	102	83	72	65	59
	3.500	260	184	150	130	116	106	196	139	113	98	88	80
	4.000	300	231	188	163	146	133	257	181	148	128	115	105
7.00	3.000	171	121	99	85	76	70	124	87	71	62	55	50
	3.500	228	161	132	114	102	93	168	119	97	84	75	69
	4.000	289	204	167	145	129	118	220	155	127	110	98	90
	4.500	300	249	203	176	157	144	278	197	161	139	124	114
	5.000	300	293	239	207	185	169	300	243	198	172	154	140
8.00	3.500	203	144	117	102	91	83	147	104	85	74	66	60
	4.000	261	185	151	131	117	107	192	136	111	96	86	79
	4.500	300	229	187	162	145	132	244	172	141	122	109	99
	5.000	300	274	224	194	174	158	300	213	174	150	134	123
	5.500	300	300	261	226	202	185	300	257	210	182	163	149
10.00	4.500	269	190	155	135	120	110	195	138	112	97	87	80
	5.000	300	232	190	164	147	134	291	206	168	146	130	119
	5.500	300	277	226	196	175	160	300	300	272	236	211	192
	7.000	300	300	300	296	265	242	241	170	139	120	108	98
12.00	5.500	300	236	193	167	149	136	243	171	140	121	108	99
	7.000	300	300	300	260	233	213	300	300	296	257	229	209
	8.000	300	300	300	300	292	267	300	278	227	196	176	160
14.00	7.000	300	300	263	228	204	186	300	238	194	168	151	137
	8.000	300	300	300	290	259	236	300	300	300	300	300	281
	10.000	300	300	300	300	300	300	300	300	254	220	197	180
16.00	8.000	300	300	300	260	233	213	300	272	222	192	172	157
	9.000	300	300	300	300	288	263	300	300	281	244	218	199
	10.000	300	300	300	300	300	300	300	300	300	300	269	245
18.00	9.000	300	300	300	293	262	239	300	300	250	216	194	177
	10.000	300	300	300	300	300	289	300	300	300	267	239	218
20.00	10.000	300	300	300	300	292	267	300	300	278	241	215	196

<sup>1</sup> Maximum operating pressure is limited for Mounting Style SB. Please refer to maximum operating pressure per bore in Pressure Ratings table located on the dimension page for Mounting Styles SB.

Custom Modifications

**⚠ PROP 65 WARNING** WARNING: This product can expose you to chemicals including **Lead and Lead Compounds** which are known to the State of California to cause cancer and birth defects or other reproductive harm. For more information go to [www.P65Warnings.ca.gov](http://www.P65Warnings.ca.gov)



**An Introduction to Cushioning**

Cushioning is recommended as a means of controlling the deceleration of masses, or for applications where piston speed is in excess of 4 in/sec and the piston will make full stroke. Cushioning extends cylinder life and reduces undesirable noise and hydraulic shock. Built-in "cushions" are optional and can be supplied at the head and cap ends of a cylinder without affecting its envelope or mounting dimensions.

**Standard Cushioning**

**Ideal cushion performance shows an almost uniform absorption of energy along the cushioning length, as shown. Many forms of cushioning exist, and each has its own specific merits and advantages.**

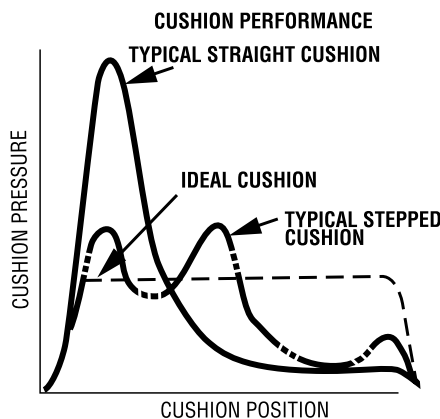

In order to cover the majority of applications, PH cylinders are supplied with profiled cushioning as standard. Final speed may be adjusted using the cushion screw. The performance of profiled cushioning is indicated on the diagram, and

cushion performance for each of the rod sizes available is illustrated graphically in the charts on the following pages.

Note: Cushion performance will be affected by the use of water or high water based fluids. Please consult factory for details.

**Cushion Length**

Where specified, PH cylinders incorporate the longest cushion sleeve and spear that can be accommodated within the standard envelope without reducing the rod bearing and piston bearing length. See cushion lengths on the next page. Cushions are adjustable via recessed needle valves.

**Cushion Calculation**

The charts on the cushion energy absorption capacity data page show the energy absorption capacity for each bore/rod combination at the head (annulus) and the cap (full bore) ends of cylinder. The charts are valid for piston velocities within a range of 0.33 to 1 ft/s. For velocities between 1ft/s and 1.64 ft/s the energy values derived from the charts should be reduced by 25%. For velocities less than 0.33 ft/s where large masses are involved, and for velocities greater than 1.60 ft/s, a special cushion profile may be required. Please consult the factory for details.

The cushion capacity of the head end is less than the cap, and reduces to zero at high drive pressures due to the pressure intensification effect across the piston.

The energy absorption capacity of the cushion decreases with drive pressure.

**Formula**

Cushioning calculations are based on the formula  $E=(1/2)mv^2$  for horizontal applications. For inclined or vertically downward or upward applications, this is modified to:

$$E = (1/2)mv^2 + mg(L/12) \times \sin(a)$$

(for inclined or vertically downward direction of mass)

$$E = (1/2)mv^2 - mg(L/12) \times \sin(a)$$

(for inclined vertically upward direction of mass)

where:

E = energy absorbed in ft-lb

g = acceleration due to gravity = 32.2 ft/s<sup>2</sup>

v = velocity in ft/s

L = length of cushion in inches (see cushion length chart on the next page).

m = mass of load in slug (including piston, rod and rod end accessories).

a = angle to the horizontal in degrees

p = pressure in psi

**Example:**

The following example shows how to calculate the energy developed by masses moving in a straight line. For non-linear motion, other calculations are required; please consult the factory. The example assumes that the bore and rod diameter are already appropriate for the application. The effects of friction on the cylinder and load have been ignored.

Selected bore/rod 6.00" bore x 2.50" rod (No. 1 rod)

Cushion at the cap end.

Pressure = 2,500 psi

Mass = 685 slugs = weight in lb / (32.2 ft/s<sup>2</sup>)

Velocity = 1.3 ft/s

Cushion length = 1.313 inch

a = 45°

Sin (a) = 0.70

$$E = (1/2)mv^2 + mgl/12 \times \text{Sin} (a)$$

$$= (1/2) \times 685 \times 1.3^2 + 685 \times 32.2 \times 1.313/12 \times 0.70$$

$$= 2,268 \text{ ft-lb}$$

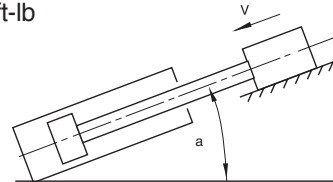

Note: In the above example velocity is greater than 1 ft/s Therefore, a de-rating factor of 0.75 must be applied to the calculated value of E. Applying this correction factor will increase the energy value to 3024 ft-lb (2268/0.75 = 3024 ft-lb). A review of the graph for the cap end cushion of a 6 inch bore x 2.50" rod cylinder operating at 2500 psi indicates that it can absorb approximately 3200 ft-lb maximum of energy. Since 3024 ft-lb is less than the maximum allowable of 3200 ft-lb, the cylinder can be applied as indicated. If the calculated energy exceeds the value shown on the curve, select a larger bore cylinder and/or reduce the operating pressure and recalculate the energy. Compare the newly calculated energy value to the appropriate curve to ensure it does not exceed the maximum allowable energy.

**⚠ PROP 65 WARNING**

**WARNING:** This product can expose you to chemicals including **Lead and Lead Compounds** which are known to the State of California to cause cancer and birth defects or other reproductive harm. For more information go to [www.P65Warnings.ca.gov](http://www.P65Warnings.ca.gov)

**Cushion Length Chart (Series PH Cylinders)**

Bore Ø	Rod Ø	Effective Cushion Length	
		Head	Cap
1.50	0.625	0.924	1.000
	1.000	0.927	1.000
2.00	1.000	0.927	0.938
	1.375	0.925	0.938
2.50	1.000	0.927	0.938
	1.750	0.928	0.938
	1.375	0.925	0.938
3.25	1.375	1.175	1.125
	2.000	0.862	1.125
	1.750	1.178	1.125
4.00	1.750	1.178	1.063
	2.500	0.869	1.063
	2.000	0.862	1.063
5.00	2.000	0.862	0.938
	3.500	0.869	0.938
	2.500	0.869	0.938
	3.000	0.869	0.938
6.00	2.500	1.119	1.313
	4.000	1.119	1.313
	3.000	1.119	1.313
	3.500	0.869	1.313
7.00	3.000	1.619	1.750
	5.000	1.496	1.750
	3.500	1.619	1.750
	4.000	1.119	1.750
	4.500	1.496	1.750
8.00	3.500	1.869	1.813
	5.500	1.745	1.813
	4.000	1.119	1.813
	4.500	1.496	1.813
	5.000	1.496	1.813

**Custom Modifications**  
**EM**

**⚠ PROP 65 WARNING** WARNING: This product can expose you to chemicals including **Lead and Lead Compounds** which are known to the State of California to cause cancer and birth defects or other reproductive harm. For more information go to [www.P65Warnings.ca.gov](http://www.P65Warnings.ca.gov)

**Cushion Energy Absorption Capacity Data**

The cushion energy absorption data shown below is based on the maximum fatigue-free pressure developed in the tube. For application with a life cycle of less than 10<sup>6</sup> cycles, greater

energy absorption figures can be applied. Please consult the factory if further information is required.

**Head End**

**STANDARD ROD DIA.**

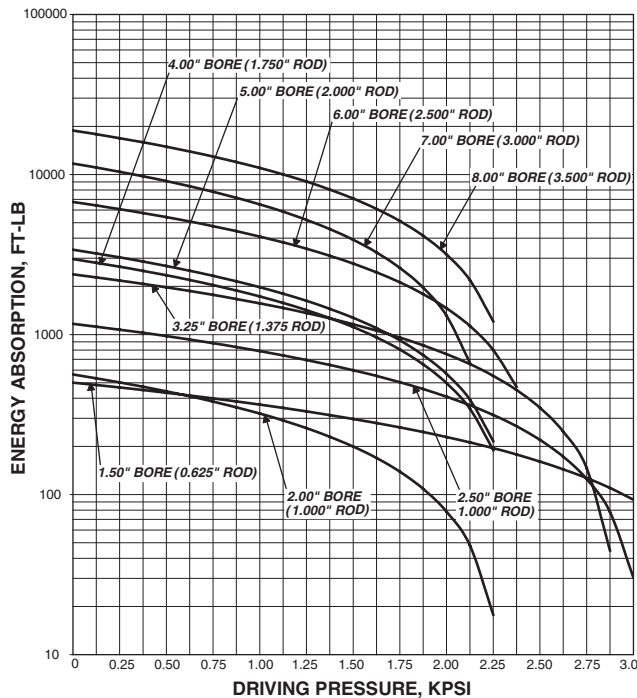

**MAXIMUM ROD DIA.**

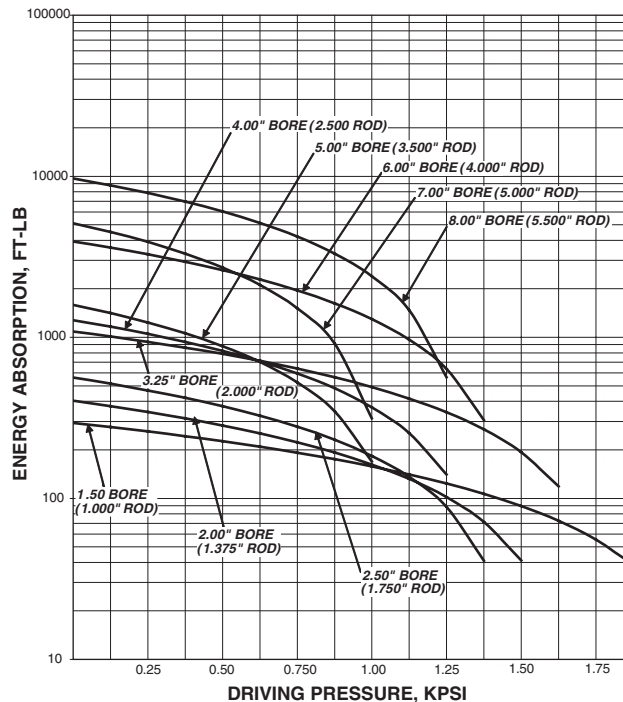

**FIRST OVERSIZE ROD DIA.**

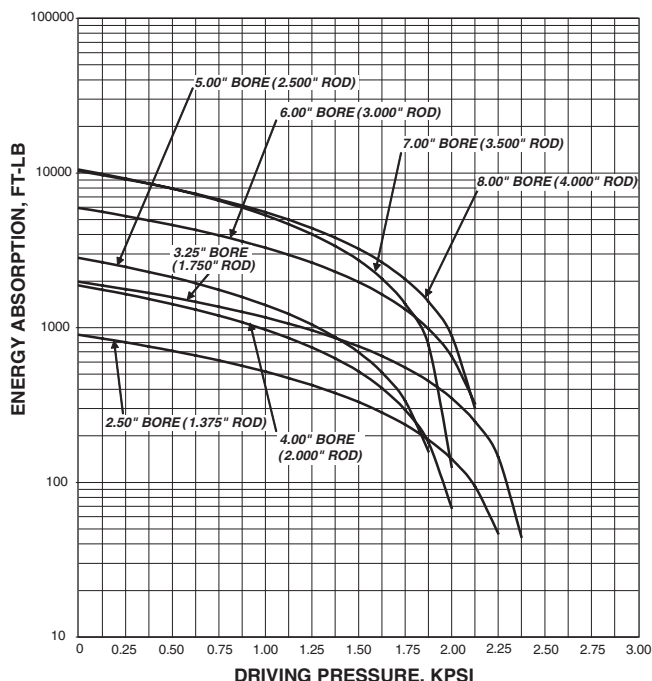

**SECOND OVERSIZE ROD DIA.**

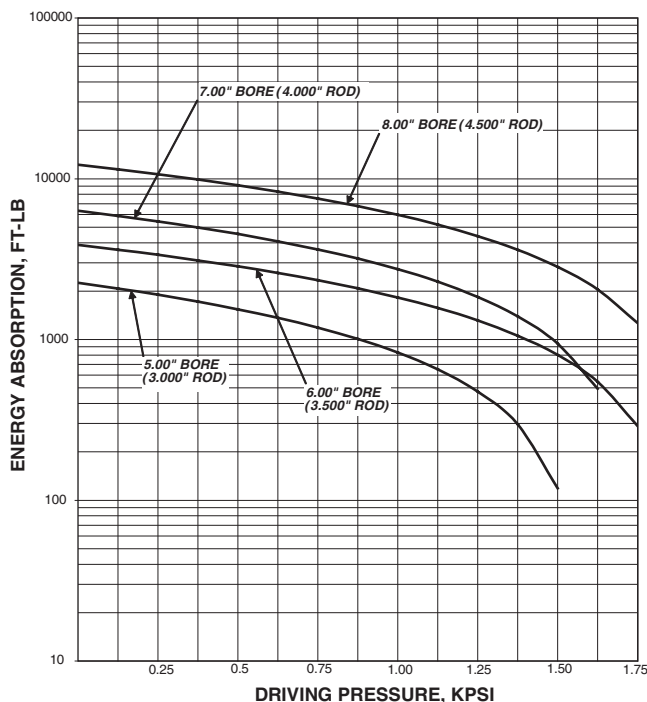

**⚠ PROP 65 WARNING** WARNING: This product can expose you to chemicals including **Lead and Lead Compounds** which are known to the State of California to cause cancer and birth defects or other reproductive harm. For more information go to [www.P65Warnings.ca.gov](http://www.P65Warnings.ca.gov)



**Cushion Energy Absorption Capacity Data**

The cushion energy absorption data shown below is based on the maximum fatigue-free pressure developed in the tube. For application with a life cycle of less than 10<sup>6</sup> cycles, greater

energy absorption figures can be applied. Please consult the factory if further information is required.

**Head End**

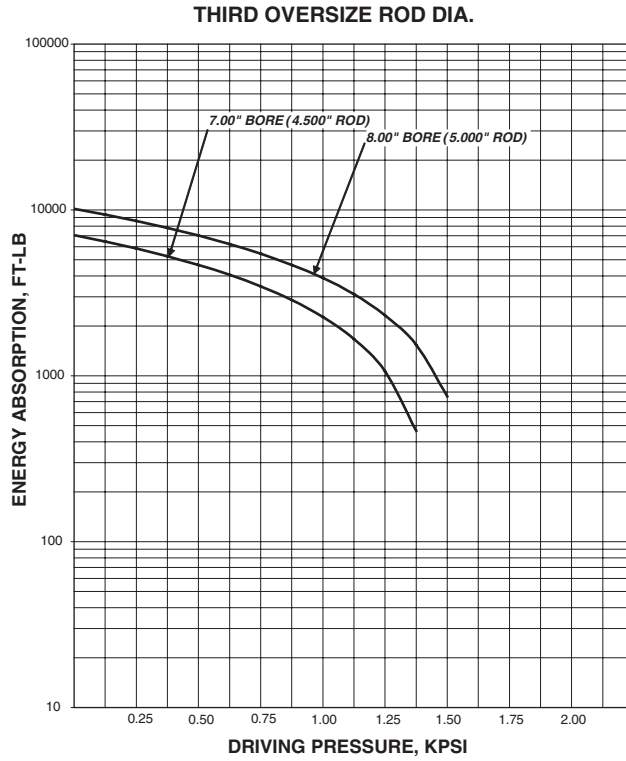

**Custom Modifications**  
**F**

**⚠ PROP 65 WARNING** WARNING: This product can expose you to chemicals including **Lead and Lead Compounds** which are known to the State of California to cause cancer and birth defects or other reproductive harm. For more information go to [www.P65Warnings.ca.gov](http://www.P65Warnings.ca.gov)

**Cushion Energy Absorption Capacity Data**

The cushion energy absorption data shown below is based on the maximum fatigue-free pressure developed in the tube. For application with a life cycle of less than 10<sup>6</sup> cycles, greater energy absorption figures can be applied. Please consult the factory if further information is required.

**Note: Cap end cushioned cylinders with oversize port and hydraulic fluid flow entering the cap that exceeds 25 ft/second should be specified with solid cap cushion design.**

**Cap End**

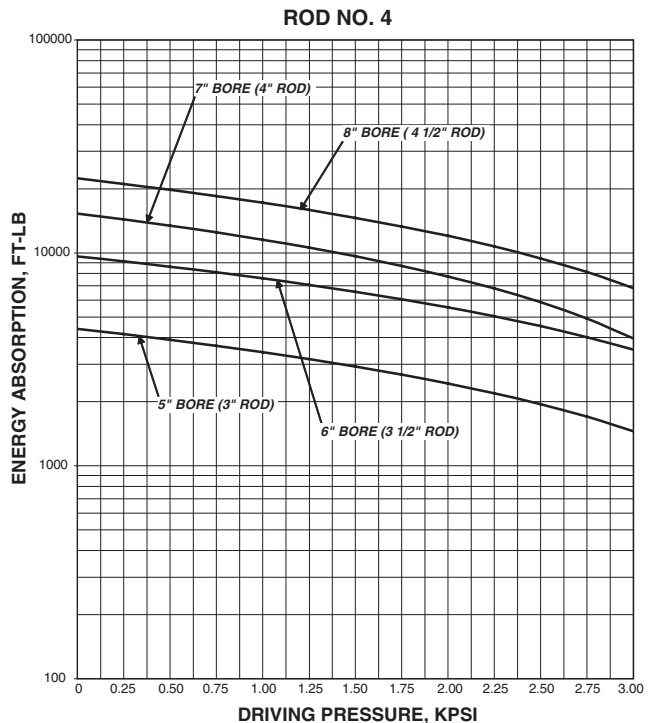
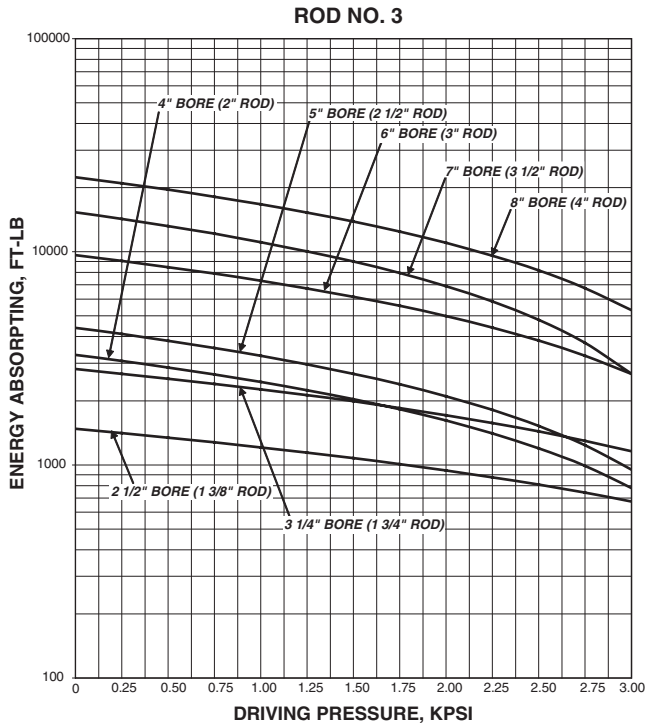
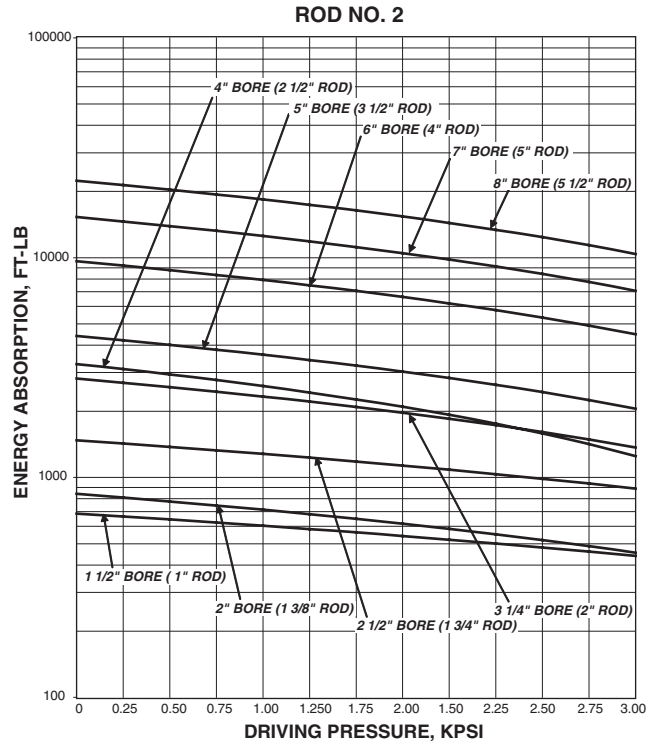
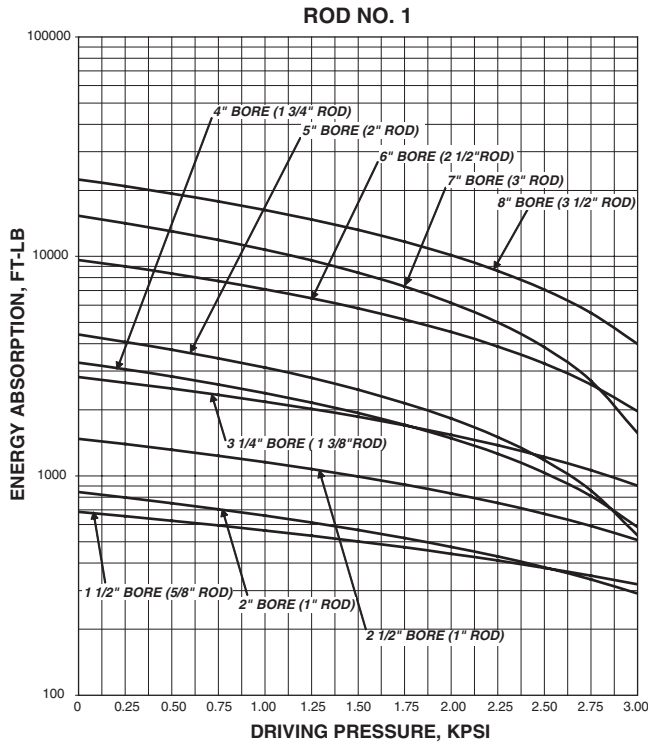

**⚠ PROP 65 WARNING** WARNING: This product can expose you to chemicals including **Lead and Lead Compounds** which are known to the State of California to cause cancer and birth defects or other reproductive harm. For more information go to [www.P65Warnings.ca.gov](http://www.P65Warnings.ca.gov)



**Cushion Energy Absorption Capacity Data**

The cushion energy absorption data shown below is based on the maximum fatigue-free pressure developed in the tube. For application with a life cycle of less than 10<sup>6</sup> cycles, greater energy absorption figures can be applied. Please consult the factory if further information is required.

**Note: Cap end cushioned cylinders with oversize port and hydraulic fluid flow entering the cap that exceeds 25 ft/second should be specified with solid cap cushion design.**

**Cap End**

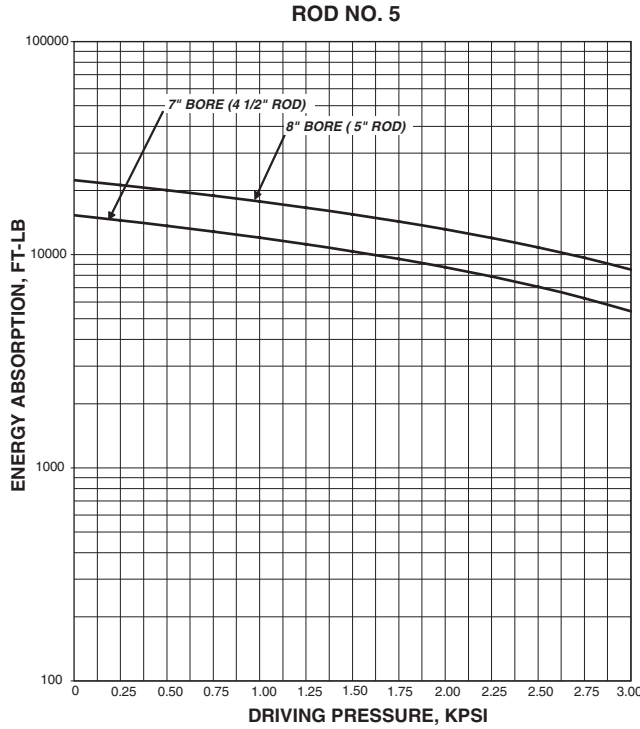

**Custom Modifications**

**⚠ PROP 65 WARNING** WARNING: This product can expose you to chemicals including **Lead and Lead Compounds** which are known to the State of California to cause cancer and birth defects or other reproductive harm. For more information go to [www.P65Warnings.ca.gov](http://www.P65Warnings.ca.gov)

**Notes**

 **PROP 65 WARNING** **WARNING:** This product can expose you to chemicals including **Lead and Lead Compounds** which are known to the State of California to cause cancer and birth defects or other reproductive harm. For more information go to [www.P65Warnings.ca.gov](http://www.P65Warnings.ca.gov)

 **PROP 65 WARNING** **WARNING:** This product can expose you to chemicals including **Lead and Lead Compounds** which are known to the State of California to cause cancer and birth defects or other reproductive harm. For more information go to [www.P65Warnings.ca.gov](http://www.P65Warnings.ca.gov)



 **PROP 65 WARNING** **WARNING:** This product can expose you to chemicals including **Lead and Lead Compounds** which are known to the State of California to cause cancer and birth defects or other reproductive harm. For more information go to [www.P65Warnings.ca.gov](http://www.P65Warnings.ca.gov)

**Safety Guide for Selecting and Using Hydraulic, Pneumatic Cylinders and Their Accessories**

**WARNING: ⚠ FAILURE OF THE CYLINDER, ITS PARTS, ITS MOUNTING, ITS CONNECTIONS TO OTHER OBJECTS, OR ITS CONTROLS CAN RESULT IN:**

- Unanticipated or uncontrolled movement of the cylinder or objects connected to it.
- Falling of the cylinder or objects held up by it.
- Fluid escaping from the cylinder, potentially at high velocity.

**THESE EVENTS COULD CAUSE DEATH OR PERSONAL INJURY BY, FOR EXAMPLE, PERSONS FALLING FROM HIGH LOCATIONS, BEING CRUSHED OR STRUCK BY HEAVY OR FAST MOVING OBJECTS, BEING PUSHED INTO DANGEROUS EQUIPMENT OR SITUATIONS, OR SLIPPING ON ESCAPED FLUID.**

Before selecting or using Parker Hannifin Corporation (the Company) cylinders or related accessories, it is important that you read, understand and follow the following safety information. Training is advised before selecting and using the Company's products.

**1.0 General Instructions**

**1.1 Scope** – This safety guide provides instructions for selecting and using (including assembling, installing, and maintaining) cylinder products. This safety guide is a supplement to and is to be used with the specific Company publications for the specific cylinder products that are being considered for use.

**1.2 Fail Safe** – Cylinder products can and do fail without warning for many reasons. All systems and equipment should be designed in a fail-safe mode so that if the failure of a cylinder product occurs people and property won't be endangered.

**1.3 Distribution** – Provide a free copy of this safety guide to each person responsible for selecting or using cylinder products. Do not select or use the Company's cylinders without thoroughly reading and understanding this safety guide as well as the specific Company publications for the products considered or selected.

**1.4 User Responsibility** – Due to very wide variety of cylinder applications and cylinder operating conditions, the Company does not warrant that any particular cylinder is suitable for any specific application. This safety guide does not analyze all technical parameters that must be considered in selecting a product. The hydraulic and pneumatic cylinders outlined in this catalog are designed to the Company's design guidelines and do not necessarily meet the design guideline of other agencies such as American Bureau of Shipping, ASME Pressure Vessel Code etc. The user, through its own analysis and testing, is solely responsible for:

- Making the final selection of the cylinders and related accessories.
- Determining if the cylinders are required to meet specific design requirements as required by the Agency(s) or industry standards covering the design of the user's equipment.
- Assuring that the user's requirements are met, OSHA requirements are met, and safety guidelines from the applicable agencies such as but not limited to ANSI are followed and that the use presents no health or safety hazards.
- Providing all appropriate health and safety warnings on the equipment on which the cylinders are used.

**1.5 Additional Questions** – Call the appropriate Company technical service department if you have any questions or require any additional information. See the Company publication for the product being considered or used, or call 1-847-298-2400, or go to [www.parker.com](http://www.parker.com), for telephone numbers of the appropriate technical service department.

**2.0 Cylinder and Accessories Selection**

**2.1 Seals** – Part of the process of selecting a cylinder is the selection of seal compounds. Before making this selection, consult the "seal information page(s)" of the publication for the series of cylinders of interest.

The application of cylinders may allow fluids such as cutting fluids, wash down fluids etc. to come in contact with the external area of the cylinder. These fluids may attack the piston rod wiper and or the primary seal and must be taken into account when selecting and specifying seal compounds.

Dynamic seals will wear. The rate of wear will depend on many operating factors. Wear can be rapid if a cylinder is mis-aligned or if the cylinder has been improperly serviced. The user must take seal wear into consideration in the application of cylinders.

**2.2 Piston Rods** – Possible consequences of piston rod failure or separation of the piston rod from the piston include, but are not limited to are:

- Piston rod and or attached load thrown off at high speed.
- High velocity fluid discharge.
- Piston rod extending when pressure is applied in the piston retract mode.

Piston rods or machine members attached to the piston rod may move suddenly and without warning as a consequence of other conditions occurring to the machine such as, but not limited to:

- Unexpected detachment of the machine member from the piston rod.
- Failure of the pressurized fluid delivery system (hoses, fittings, valves, pumps, compressors) which maintain cylinder position.
- Catastrophic cylinder seal failure leading to sudden loss of pressurized fluid.
- Failure of the machine control system.

Follow the recommendations of the "Piston Rod Selection Chart and Data" in the publication for the series of cylinders of interest. The suggested piston rod diameter in these charts must be followed in order to avoid piston rod buckling.

Piston rods are not normally designed to absorb bending moments or loads which are perpendicular to the axis of piston rod motion. These additional loads can cause the piston rod to fail. If these types of additional loads are expected to be imposed on the piston rod, their magnitude should be made known to our engineering department.

The cylinder user should always make sure that the piston rod is securely attached to the machine member.

On occasion cylinders are ordered with double rods (a piston rod extended from both ends of the cylinder). In some cases a stop is threaded on to one of the piston rods and used as an external stroke adjuster. On occasions spacers are attached to the machine member connected to the piston rod and also used as a stroke adjuster. In both cases the stops will create a pinch point and the user should consider appropriate use of guards. If these external stops are not perpendicular to the mating contact surface, or if debris is trapped between the contact surfaces, a bending moment will be placed on the piston rod, which can lead to piston rod failure. An external stop will also negate the effect of cushioning and will subject the piston rod to impact loading. Those two (2) conditions can cause piston rod failure. Internal stroke adjusters are available with and without cushions. The use of external stroke adjusters should be reviewed with our engineering department.

The piston rod to piston and the stud to piston rod threaded connections are secured with an anaerobic adhesive. The strength of the adhesive decreases with increasing temperature. Cylinders which can be exposed to temperatures above +250°F (+121°C) are to be ordered with a non studded piston rod and a pinned piston to rod joint.

**2.3 Cushions** – Cushions should be considered for cylinder applications when the piston velocity is expected to be over 4 inches/second.

Cylinder cushions are normally designed to absorb the energy of a linear applied load. A rotating mass has considerably more energy than the same mass moving in a linear mode. Cushioning for a rotating mass application should be reviewed by our engineering department.

**2.4 Cylinder Mountings** – Some cylinder mounting configurations may have certain limitations such as but not limited to minimum stroke for side or foot mounting cylinders or pressure de-ratings for certain mounts. Carefully review the catalog for these types of restrictions.

Always mount cylinders using the largest possible high tensile alloy steel socket head cap screws that can fit in the cylinder mounting holes and torque them to the manufacturer's recommendations for their size.

**2.5 Port Fittings** – Hydraulic cylinders applied with meter out or deceleration circuits are subject to intensified pressure at piston rod end.

The rod end pressure is approximately equal to:

$$\frac{\text{operating pressure} \times \text{effective cap end area}}{\text{effective rod end piston area}}$$

Contact your connector supplier for the pressure rating of individual connectors.

**3.0 Cylinder and Accessories Installation and Mounting**

**3.1 Installation**

**3.1.1** – Cleanliness is an important consideration, and cylinders are shipped with the ports plugged to protect them from contaminants entering the ports. These plugs should not be removed until the piping is to be installed. Before making the connection to the cylinder ports, piping should be thoroughly cleaned to remove all chips or burrs which might have resulted from threading or flaring operations.

**⚠ PROP 65 WARNING** WARNING: This product can expose you to chemicals including **Lead and Lead Compounds** which are known to the State of California to cause cancer and birth defects or other reproductive harm. For more information go to [www.P65Warnings.ca.gov](http://www.P65Warnings.ca.gov)

**3.1.2** – Cylinders operating in an environment where air drying materials are present such as fast-drying chemicals, paint, or weld splatter, or other hazardous conditions such as excessive heat, should have shields installed to prevent damage to the piston rod and piston rod seals.

**3.1.3** – Proper alignment of the cylinder piston rod and its mating component on the machine should be checked in both the extended and retracted positions. Improper alignment will result in excessive rod bushing and/or cylinder bore wear. On fixed mounting cylinders attaching the piston rod while the rod is retracted will help in achieving proper alignment.

**3.1.4** – Sometimes it may be necessary to rotate the piston rod in order to thread the piston rod into the machine member. This operation must always be done with zero pressure being applied to either side of the piston. Failure to follow this procedure may result in loosening the piston to rod-threaded connection. In some rare cases the turning of the piston rod may rotate a threaded piston rod bushing and loosen it from the cylinder head. Confirm that this condition is not occurring. If it does, re-tighten the piston rod bushing firmly against the cylinder head.

For double rod cylinders it is also important that when attaching or detaching the piston rod from the machine member that the torque be applied to the piston rod end of the cylinder that is directly attaching to the machine member with the opposite end unrestrained. If the design of the machine is such that only the rod end of the cylinder opposite to where the rod attaches to the machine member can be rotated, consult the factory for further instructions.

### **3.2 Mounting Recommendations**

**3.2.1** – Always mount cylinders using the largest possible high tensile alloy steel socket head screws that can fit in the cylinder mounting holes and torque them to the manufacturer's recommendations for their size.

**3.2.2** – Side-Mounted Cylinders – In addition to the mounting bolts, cylinders of this type should be equipped with thrust keys or dowel pins located so as to resist the major load.

**3.2.3** – Tie Rod Mounting – Cylinders with tie rod mountings are recommended for applications where mounting space is limited. The standard tie rod extension is shown as BB in dimension tables. Longer or shorter extensions can be supplied. Nuts used for this mounting style should be torqued to the same value as the tie rods for that bore size.

**3.2.4** – Flange Mount Cylinders – The controlled diameter of the rod bushing extension on head end flange mount cylinders can be used as a pilot to locate the cylinders in relation to the machine. After alignment has been obtained, the flanges may be drilled for pins or dowels to prevent shifting.

**3.2.5** – Trunnion Mountings – Cylinders require lubricated bearing blocks with minimum bearing clearances. Bearing blocks should be carefully aligned and rigidly mounted so the trunnions will not be subjected to bending moments. The rod end should also be pivoted with the pivot pin in line and parallel to axis of the trunnion pins.

**3.2.6** – Clevis Mountings – Cylinders should be pivoted at both ends with centerline of pins parallel to each other. After cylinder is mounted, be sure to check to assure that the cylinder is free to swing through its working arc without interference from other machine parts.

### **4.0 Cylinder and Accessories Maintenance, Troubleshooting and Replacement**

**4.1 Storage** – At times cylinders are delivered before a customer is ready to install them and must be stored for a period of time. When storage is required the following procedures are recommended.

**4.1.1** – Store the cylinders in an indoor area which has a dry, clean and noncorrosive atmosphere. Take care to protect the cylinder from both internal corrosion and external damage.

**4.1.2** – Whenever possible cylinders should be stored in a vertical position (piston rod up). This will minimize corrosion due to possible condensation which could occur inside the cylinder. This will also minimize seal damage.

**4.1.3** – Port protector plugs should be left in the cylinder until the time of installation.

**4.1.4** – If a cylinder is stored full of hydraulic fluid, expansion of the fluid due to temperature changes must be considered. Installing a check valve with free flow out of the cylinder is one method.

**4.1.5** – When cylinders are mounted on equipment that is stored outside for extended periods, exposed unpainted surfaces, e.g. piston rod, must be coated with a rust-inhibiting compound to prevent corrosion.

### **4.2 Cylinder Trouble Shooting**

#### **4.2.1 – External Leakage**

**4.2.1.1** – Rod seal leakage can generally be traced to worn or damaged seals. Examine the piston rod for dents, gouges or score

marks, and replace piston rod if surface is rough.

Rod seal leakage could also be traced to bushing wear. If clearance is excessive, replace rod bushing and seal. Rod seal leakage can also be traced to seal deterioration. If seals are soft or gummy or brittle, check compatibility of seal material with lubricant used if air cylinder, or operating fluid if hydraulic cylinder. Replace with seal material, which is compatible with these fluids. If the seals are hard or have lost elasticity, it is usually due to exposure to temperatures in excess of 165°F. (+74°C). Shield the cylinder from the heat source to limit temperature to 350°F. (+177°C.) and replace with fluorocarbon seals.

**4.2.1.2** – Cylinder body seal leak can generally be traced to loose tie rods. Torque the tie rods to manufacturer's recommendation for that bore size.

Excessive pressure can also result in cylinder body seal leak. Determine maximum pressure to rated limits. Replace seals and retorqued tie rods as in paragraph above. Excessive pressure can also result in cylinder body seal leak. Determine if the pressure rating of the cylinder has been exceeded. If so, bring the operating pressure down to the rating of the cylinder and have the tie rods replaced.

Pinched or extruded cylinder body seal will also result in a leak. Replace cylinder body seal and retorqued as in paragraph above.

Cylinder body seal leakage due to loss of radial squeeze which shows up in the form of flat spots or due to wear on the O.D. or I.D. – Either of these are symptoms of normal wear due to high cycle rate or length of service. Replace seals as per paragraph above.

#### **4.2.2 – Internal Leakage**

**4.2.2.1** – Piston seal leak (by-pass) 1 to 3 cubic inches per minute leakage is considered normal for piston ring construction. Virtually no static leak with lipseal type seals on piston should be expected. Piston seal wear is a usual cause of piston seal leakage. Replace seals as required.

**4.2.2.2** – With lipseal type piston seals excessive back pressure due to over-adjustment of speed control valves could be a direct cause of rapid seal wear. Contamination in a hydraulic system can result in a scored cylinder bore, resulting in rapid seal wear. In either case, replace piston seals as required.

**4.2.2.3** – What appears to be piston seal leak, evidenced by the fact that the cylinder drifts, is not always traceable to the piston. To make sure, it is suggested that one side of the cylinder piston be pressurized and the fluid line at the opposite port be disconnected. Observe leakage. If none is evident, seek the cause of cylinder drift in other component parts in the circuit.

#### **4.2.3 – Cylinder Fails to Move the Load**

**4.2.3.1** – Pneumatic or hydraulic pressure is too low. Check the pressure at the cylinder to make sure it is to circuit requirements.

**4.2.3.2** – Piston Seal Leak – Operate the valve to cycle the cylinder and observe fluid flow at valve exhaust ports at end of cylinder stroke. Replace piston seals if flow is excessive.

**4.2.3.3** – Cylinder is undersized for the load – Replace cylinder with one of a larger bore size.

#### **4.3 Erratic or Chatter Operation**

**4.3.1** – Excessive friction at rod bushing or piston bearing due to load misalignment – Correct cylinder-to-load alignment.

**4.3.2** – Cylinder sized too close to load requirements – Reduce load or install larger cylinder.

**4.3.3** – Erratic operation could be traced to the difference between static and kinetic friction. Install speed control valves to provide a back pressure to control the stroke.

**4.4 Cylinder Modifications, Repairs, or Failed Component** – Cylinders as shipped from the factory are not to be disassembled and or modified. If cylinders require modifications, these modifications must be done at company locations or by the Company's certified facilities. The Cylinder Division Engineering Department must be notified in the event of a mechanical fracture or permanent deformation of any cylinder component (excluding seals). This includes a broken piston rod, tie rod, mounting accessory or any other cylinder component. The notification should include all operation and application details. This information will be used to provide an engineered repair that will prevent recurrence of the failure.

It is allowed to disassemble cylinders for the purpose of replacing seals or seal assemblies. However, this work must be done by strictly following all the instructions provided with the seal kits.

**⚠ PROP 65 WARNING** WARNING: This product can expose you to chemicals including **Lead and Lead Compounds** which are known to the State of California to cause cancer and birth defects or other reproductive harm. For more information go to [www.P65Warnings.ca.gov](http://www.P65Warnings.ca.gov)

## Offer of Sale

The items described in this document and other documents and descriptions provided by Parker Hannifin Corporation, its subsidiaries and its authorized distributors ("Seller") are hereby offered for sale at prices to be established by Seller. This offer and its acceptance by any customer ("Buyer") shall be governed by all of the following Terms and Conditions. Buyer's order for any item described in its document, when communicated to Seller verbally, or in writing, shall constitute acceptance of this offer. All goods, services or work described will be referred to as "Products".

**1. Terms and Conditions.** Seller's willingness to offer Products, or accept an order for Products, to or from Buyer is subject to these Terms and Conditions or any newer version of the terms and conditions found on-line at [www.parker.com/saleterms/](http://www.parker.com/saleterms/). Seller objects to any contrary or additional terms or conditions of Buyer's order or any other document issued by Buyer.

**2. Price Adjustments; Payments.** Prices stated on Seller's quote or other documentation offered by Seller are valid for 30 days, and do not include any sales, use, or other taxes unless specifically stated. Unless otherwise specified by Seller, all prices are F.C.A. Seller's facility (INCOTERMS 2010). Payment is subject to credit approval and is due 30 days from the date of invoice or such other term as required by Seller's Credit Department, after which Buyer shall pay interest on any unpaid invoices at the rate of 1.5% per month or the maximum allowable rate under applicable law.

**3. Delivery Dates; Title and Risk; Shipment.** All delivery dates are approximate and Seller shall not be responsible for any damages resulting from any delay. Regardless of the manner of shipment, title to any products and risk of loss or damage shall pass to Buyer upon placement of the products with the shipment carrier at Seller's facility. Unless otherwise stated, Seller may exercise its judgment in choosing the carrier and means of delivery. No deferral of shipment at Buyers' request beyond the respective dates indicated will be made except on terms that will indemnify, defend and hold Seller harmless against all loss and additional expense. Buyer shall be responsible for any additional shipping charges incurred by Seller due to Buyer's acts or omissions.

**4. Warranty.** Seller warrants that the Products sold hereunder shall be free from defects in material or workmanship for a period of eighteen months from the date of delivery to Buyer. The prices charged for Seller's products are based upon the exclusive limited warranty stated above, and upon the following disclaimer: **DISCLAIMER OF WARRANTY: THIS WARRANTY COMPRISES THE SOLE AND ENTIRE WARRANTY PERTAINING TO PRODUCTS PROVIDED HEREUNDER. SELLER DISCLAIMS ALL OTHER WARRANTIES, EXPRESS AND IMPLIED, INCLUDING DESIGN, MERCHANTABILITY AND FITNESS FOR A PARTICULAR PURPOSE.**

**5. Claims; Commencement of Actions.** Buyer shall promptly inspect all Products upon delivery. No claims for shortages will be allowed unless reported to the Seller within 10 days of delivery. No other claims against Seller will be allowed unless asserted in writing within 30 days after delivery. Buyer shall notify Seller of any alleged breach of warranty within 30 days after the date the defect is or should have been discovered by Buyer. Any action based upon breach of this agreement or upon any other claim arising out of this sale (other than an action by Seller for an amount due on any invoice) must be commenced within 12 months from the date of the breach without regard to the date breach is discovered.

**6. LIMITATION OF LIABILITY.** UPON NOTIFICATION, SELLER WILL, AT ITS OPTION, REPAIR OR REPLACE A DEFECTIVE PRODUCT, OR REFUND THE PURCHASE PRICE. **IN NO EVENT SHALL SELLER BE LIABLE TO BUYER FOR ANY SPECIAL, INDIRECT, INCIDENTAL OR CONSEQUENTIAL DAMAGES ARISING OUT OF, OR AS THE RESULT OF, THE SALE, DELIVERY, NON-DELIVERY, SERVICING, USE OR LOSS OF USE OF THE PRODUCTS OR ANY PART THEREOF, OR FOR ANY CHARGES OR EXPENSES OF ANY NATURE INCURRED WITHOUT SELLER'S WRITTEN CONSENT, EVEN IF SELLER HAS BEEN NEGLIGENT, WHETHER IN CONTRACT, TORT OR OTHER LEGAL THEORY. IN NO EVENT SHALL SELLER'S LIABILITY UNDER ANY CLAIM MADE BY BUYER EXCEED THE PURCHASE PRICE OF THE PRODUCTS.**

**7. User Responsibility.** The user, through its own analysis and testing, is solely responsible for making the final selection of the system and Product and assuring that all performance, endurance, maintenance, safety and warning requirements of the application are met. The user must analyze all aspects of the application and follow applicable industry standards and Product information. If Seller provides Product or system options, the user is responsible for determining that such data and specifications are suitable and sufficient for all applications and reasonably foreseeable uses of the Products or systems.

**8. Loss to Buyer's Property.** Any designs, tools, patterns, materials, drawings, confidential information or equipment furnished by Buyer or any other items which become Buyer's property, will be considered obsolete and may be destroyed by Seller after two consecutive years have elapsed without Buyer ordering the items manufactured using such property. Seller shall not be responsible for any loss or damage to such property while it is in Seller's possession or control.

**9. Special Tooling.** A tooling charge may be imposed for any special tooling, including without limitation, dies, fixtures, molds and patterns, acquired to manufacture Products. Such special tooling shall be and remain Seller's property notwithstanding payment of any charges by Buyer. In no event will Buyer acquire any interest in apparatus belonging to Seller which is utilized in the manufacture of the Products, even if such apparatus has been specially converted or adapted for such manufacture and notwithstanding any charges paid by Buyer. Unless otherwise agreed, Seller shall have the right to alter, discard or otherwise dispose of any special tooling or other property in its sole discretion at any time.

**10. Buyer's Obligation; Rights of Seller.** To secure payment of all sums due or otherwise, Seller shall retain a security interest in the goods delivered and this agreement shall be deemed a Security Agreement under the Uniform Commercial Code. Buyer authorizes Seller as its attorney to execute and file on Buyer's behalf all documents Seller deems necessary to perfect its security interest.

**11. Improper use and Indemnity.** Buyer shall indemnify, defend, and hold Seller harmless from any claim, liability, damages, lawsuits, and costs (including attorney fees), whether for personal injury, property damage, patent, trademark or copyright

infringement or any other claim, brought by or incurred by Buyer, Buyer's employees, or any other person, arising out of: (a) improper selection, improper application or other misuse of Products purchased by Buyer from Seller; (b) any act or omission, negligent or otherwise, of Buyer; (c) Seller's use of patterns, plans, drawings, or specifications furnished by Buyer to manufacture Product; or (d) Buyer's failure to comply with these terms and conditions. Seller shall not indemnify Buyer under any circumstance except as otherwise provided.

**12. Cancellations and Changes.** Orders shall not be subject to cancellation or change by Buyer for any reason, except with Seller's written consent and upon terms that will indemnify, defend and hold Seller harmless against all direct, incidental and consequential loss or damage. Seller may change product features, specifications, designs and availability with notice to Buyer.

**13. Limitation on Assignment.** Buyer may not assign its rights or obligations under this agreement without the prior written consent of Seller.

**14. Force Majeure.** Seller does not assume the risk and shall not be liable for delay or failure to perform any of Seller's obligations by reason of circumstances beyond the reasonable control of Seller (hereinafter "Events of Force Majeure"). Events of Force Majeure shall include without limitation: accidents, strikes or labor disputes, acts of any government or government agency, acts of nature, delays or failures in delivery from carriers or suppliers, shortages of materials, or any other cause beyond Seller's reasonable control.

**15. Waiver and Severability.** Failure to enforce any provision of this agreement will not waive that provision nor will any such failure prejudice Seller's right to enforce that provision in the future. Invalidation of any provision of this agreement by legislation or other rule of law shall not invalidate any other provision herein. The remaining provisions of this agreement will remain in full force and effect.

**16. Termination.** Seller may terminate this agreement for any reason and at any time by giving Buyer thirty (30) days written notice of termination. Seller may immediately terminate this agreement, in writing, if Buyer: (a) commits a breach of any provision of this agreement (b) appointments a trustee, receiver or custodian for all or any part of Buyer's property (c) files a petition for relief in bankruptcy on its own behalf, or by a third party (d) makes an assignment for the benefit of creditors, or (e) dissolves or liquidates all or a majority of its assets.

**17. Governing Law.** This agreement and the sale and delivery of all Products hereunder shall be deemed to have taken place in and shall be governed and construed in accordance with the laws of the State of Ohio, as applicable to contracts executed and wholly performed therein and without regard to conflicts of laws principles. Buyer irrevocably agrees and consents to the exclusive jurisdiction and venue of the courts of Cuyahoga County, Ohio with respect to any dispute, controversy or claim arising out of or relating to this agreement.

**18. Indemnity for Infringement of Intellectual Property Rights.** Seller shall have no liability for infringement of any patents, trademarks, copyrights, trade dress, trade secrets or similar rights except as provided in this Section. Seller will defend and indemnify Buyer against allegations of infringement of U.S. patents, U.S. trademarks, copyrights, trade dress and trade secrets ("Intellectual Property Rights"). Seller will defend at its expense and will pay the cost of any settlement or damages awarded in an action brought against Buyer based on an allegation that a Product sold pursuant to this Agreement infringes the Intellectual Property Rights of a third party. Seller's obligation to defend and indemnify Buyer is contingent on Buyer notifying Seller within ten (10) days after Buyer becomes aware of such allegations of infringement, and Seller having sole control over the defense of any allegations or actions including all negotiations for settlement or compromise. If a Product is subject to a claim that it infringes the Intellectual Property Rights of a third party, Seller may, at its sole expense and option, procure for Buyer the right to continue using the Product, replace or modify the Product so as to make it noninfringing, or offer to accept return of the Product and return the purchase price less a reasonable allowance for depreciation. Notwithstanding the foregoing, Seller shall have no liability for claims of infringement based on information provided by Buyer, or directed to Products delivered hereunder for which the designs are specified in whole or part by Buyer, or infringements resulting from the modification, combination or use in a system of any Product sold hereunder. The foregoing provisions of this Section shall constitute Seller's sole and exclusive liability and Buyer's sole and exclusive remedy for infringement of Intellectual Property Rights.

**19. Entire Agreement.** This agreement contains the entire agreement between the Buyer and Seller and constitutes the final, complete and exclusive expression of the terms of sale. All prior or contemporaneous written or oral agreements or negotiations with respect to the subject matter are herein merged.

**20. Compliance with Law, U. K. Bribery Act and U.S. Foreign Corrupt Practices Act.** Buyer agrees to comply with all applicable laws and regulations, including those of the United Kingdom and the United States of America, and of the country or countries of the Territory in which Buyer may operate, including without limitation the U. K. Bribery Act, the U.S. Foreign Corrupt Practices Act ("FCPA") and the U.S. Anti-Kickback Act (the "Anti-Kickback Act"), and agrees to indemnify and hold harmless Seller from the consequences of any violation of such provisions by Buyer, its employees or agents. Buyer acknowledges that they are familiar with the provisions of the U. K. Bribery Act, the FCPA and the Anti-Kickback Act, and certifies that Buyer will adhere to the requirements thereof. In particular, Buyer represents and agrees that Buyer shall not make any payment or give anything of value, directly or indirectly to any governmental official, any foreign political party or official thereof, any candidate for foreign political office, or any commercial entity or person, for the purpose of influencing such person to purchase products or otherwise benefit the business of Seller.

**⚠ PROP 65 WARNING** WARNING: This product can expose you to chemicals including **Lead and Lead Compounds** which are known to the State of California to cause cancer and birth defects or other reproductive harm. For more information go to [www.P65Warnings.ca.gov](http://www.P65Warnings.ca.gov)

# Custom Modifications Engineered to Order

*exclusively for Schrader Bellows PH Series cylinders*

Looking for an NFPA Interchangeable  
non Tie Rod Cylinder?

***Consider a PH B modification***

- Easier to service
- Offers a clean appearance
- Improves aesthetics particularly in longer stroke applications
- Improved fatigue life compared to industrial welded flange construction

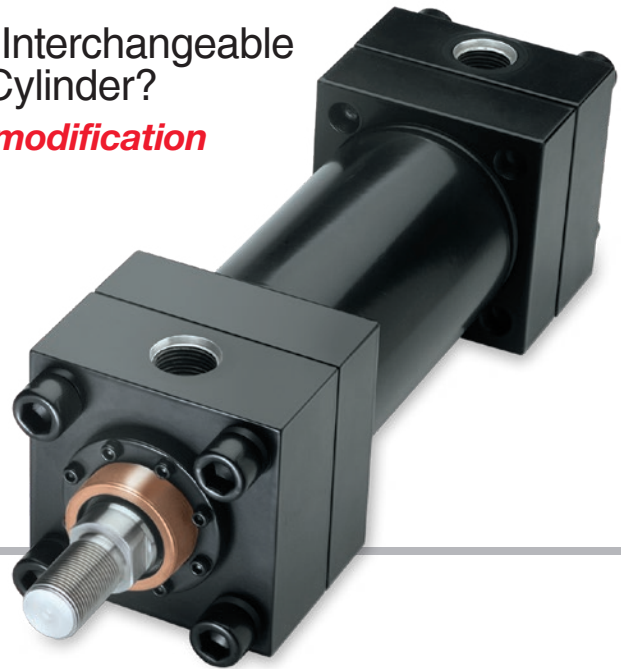

Looking to cleanly integrate your PH into  
your Electrohydraulic system?

***Consider a PH X modification***

Engineered for your feedback/  
control systems with  
transducer, valve manifold and  
hydraulic plumbing options.

All units are electronically  
tested to verify your required  
outputs prior to shipment.



Consult your local Schrader Bellows representative today



**Schrader Bellows**

500 South Wolf Road  
Des Plaines, IL 60016

Tel: (847) 298-2400

Fax: (800) 892-1008

Email: [Cylmktg@parker.com](mailto:Cylmktg@parker.com)

Web site: <http://www.schrader-bellows.com>

---

Catalog HY08-SB1314-1/NA  
08/19

© Copyright 2019  
Parker Hannifin Corporation  
All rights reserved.