

COVER PLATES

D02 Cover Plates	Page 70
D03 Cover Plates	Page 71
D05 Cover Plates	Page 72
D05 Cover Plates with Pilot Ports	Page 73
D07 Cover Plates	Page 74
D08 Cover Plates	Page 75
D10 Cover Plates	Page 76
2F06, 2F07 Cover Plates	Page 77
P06, P08, P10 Cover Plates	Page 78
R06, R08, R10 Cover Plates	Page 79
I08, I10 Cover Plates	Page 79
S04, S06 Cover Plates	Pages 80-81
Mounting Hardware	Pages 82-83



Cover Plates

The pages in this section are our standard product offerings for cover plates. If you need a custom cover plate solution please visit www.daman.com for Request For Quote (RFQ) instructions.

D02 Cover Plates

Parallel Circuit Cover Plate with Gauge Port

Cover Plate mounting hardware is supplied. *

See page 82 for itemized list.

* Plug not supplied for metric gauge port.

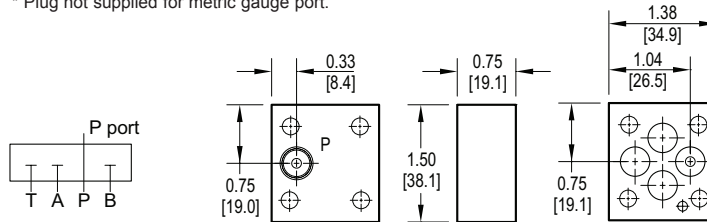

Series Circuit Cover Plate: P to T

Cover Plate mounting hardware is supplied.

See page 82 for itemized list.

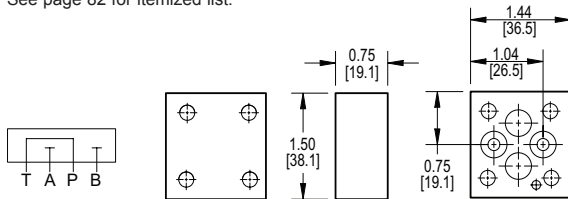

Crossover Cover Plate: P to A; B to T

Cover Plate mounting hardware is supplied.

See page 82 for itemized list.

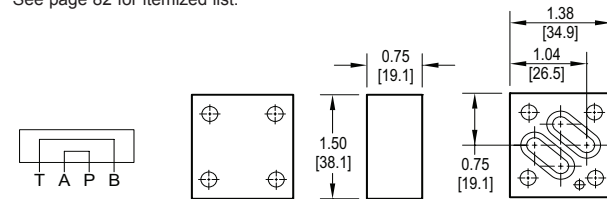

Specifications, descriptions, and dimensional data are subject to correction or change without notice or incurring obligation. Download latest catalog page revisions at www.daman.com.

Ordering Information

Material	Valve Pattern	Circuit	Gauge Port	Bolt Threads																																
<table border="1"> <thead> <tr> <th colspan="2">Material</th> </tr> </thead> <tbody> <tr> <td>A</td> <td>Aluminum - 6061-T6 3000[†] psi • 20.7 MPa</td> </tr> <tr> <td>D</td> <td>Ductile Iron - D4512 5000[†] psi • 34.5 MPa</td> </tr> <tr> <td colspan="2">[†] Working pressure should be considered in accordance with ISO 4413 to determine appropriate material type.</td> </tr> </tbody> </table>	Material		A	Aluminum - 6061-T6 3000 [†] psi • 20.7 MPa	D	Ductile Iron - D4512 5000 [†] psi • 34.5 MPa	[†] Working pressure should be considered in accordance with ISO 4413 to determine appropriate material type.		<table border="1"> <thead> <tr> <th colspan="2">Valve Pattern</th> </tr> </thead> <tbody> <tr> <td>D02</td> <td>ISO 4401-02-01 NFPA T3.5.1-D02 See Tech Information</td> </tr> </tbody> </table>	Valve Pattern		D02	ISO 4401-02-01 NFPA T3.5.1-D02 See Tech Information	<table border="1"> <thead> <tr> <th colspan="2">Circuit</th> </tr> </thead> <tbody> <tr> <td>CPP</td> <td>Parallel Circuit</td> </tr> <tr> <td>CPS</td> <td>Series Circuit</td> </tr> <tr> <td>COP</td> <td>Crossover Circuit (P to A, B to T)</td> </tr> </tbody> </table>	Circuit		CPP	Parallel Circuit	CPS	Series Circuit	COP	Crossover Circuit (P to A, B to T)	<table border="1"> <thead> <tr> <th colspan="2">Gauge Port</th> </tr> </thead> <tbody> <tr> <td colspan="2">Required with CPP circuit. Omit on CPS and COP circuits.</td> </tr> <tr> <td>G</td> <td>0.125 NPTF or 0.125 BSPT (M option)</td> </tr> </tbody> </table>	Gauge Port		Required with CPP circuit. Omit on CPS and COP circuits.		G	0.125 NPTF or 0.125 BSPT (M option)	<table border="1"> <thead> <tr> <th colspan="2">Bolt Threads</th> </tr> </thead> <tbody> <tr> <td colspan="2">Omit for inch (UNC) bolt kit.</td> </tr> <tr> <td>M</td> <td>Metric (ISO 6H) bolt kit</td> </tr> </tbody> </table>	Bolt Threads		Omit for inch (UNC) bolt kit.		M	Metric (ISO 6H) bolt kit
Material																																				
A	Aluminum - 6061-T6 3000 [†] psi • 20.7 MPa																																			
D	Ductile Iron - D4512 5000 [†] psi • 34.5 MPa																																			
[†] Working pressure should be considered in accordance with ISO 4413 to determine appropriate material type.																																				
Valve Pattern																																				
D02	ISO 4401-02-01 NFPA T3.5.1-D02 See Tech Information																																			
Circuit																																				
CPP	Parallel Circuit																																			
CPS	Series Circuit																																			
COP	Crossover Circuit (P to A, B to T)																																			
Gauge Port																																				
Required with CPP circuit. Omit on CPS and COP circuits.																																				
G	0.125 NPTF or 0.125 BSPT (M option)																																			
Bolt Threads																																				
Omit for inch (UNC) bolt kit.																																				
M	Metric (ISO 6H) bolt kit																																			

For **coating options** see pages 245-246.

D03 Cover Plates

Parallel Circuit Cover Plate

Cover Plate mounting hardware is supplied.
See page 82 for itemized list.

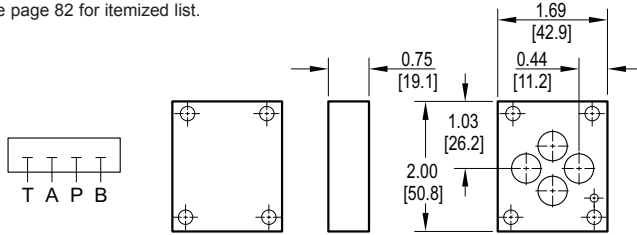

Parallel Circuit Cover Plate with Gauge Port

Cover Plate mounting hardware is supplied. *
See page 82 for itemized list.
* Plug not supplied for metric gauge port.

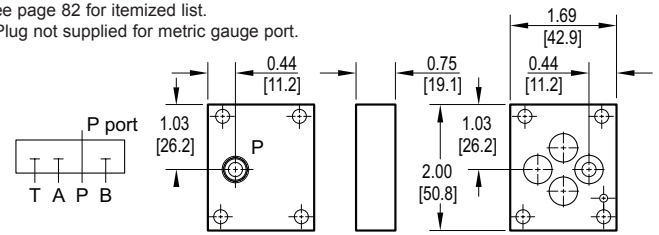

Series Circuit Cover Plate: P to T

Cover Plate mounting hardware is supplied.
See page 82 for itemized list.

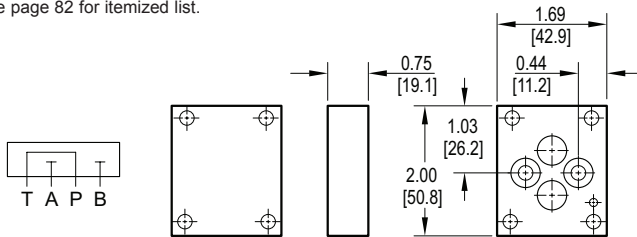

Crossover Cover Plate: P to A; B to T or P to B; A to T

Cover Plate mounting hardware is supplied.
See page 82 for itemized list.

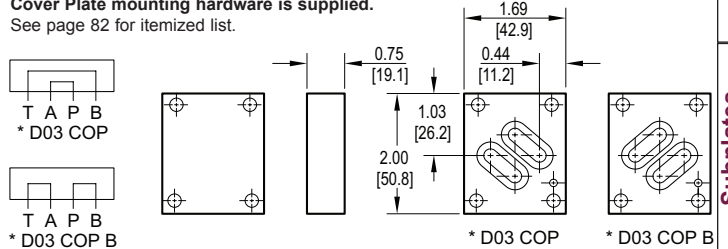

Specifications, descriptions, and dimensional data are subject to correction or change without notice or incurring obligation. Download latest catalog page revisions at www.daman.com.

Ordering Information

Material	Valve Pattern	Circuit	Gauge Port	Bolt Threads
----------	---------------	---------	------------	--------------

For **coating options** see pages 245-246.

Material	
A	Aluminum - 6061-T6 3000† psi • 20.7 MPa
D	Ductile Iron - D4512 5000† psi • 34.5 MPa

† Working pressure should be considered in accordance with ISO 4413 to determine appropriate material type.

Circuit	
CPP	Parallel Circuit
CPS	Series Circuit
COP	Crossover Circuit (P to A, B to T)
COPB	Crossover Circuit (P to B, A to T)

Bolt Threads	
Omit for inch (UNC) bolt kit.	
M	Metric (ISO 6H) bolt kit

Valve Pattern	
D03	ISO 4401-03-02 NFPA T3.5.1-D03 See Tech Information

Gauge Port	
Available with parallel circuit only. Omit if not required.	
G	0.125 NPTF or 0.125 BSPT (M option)

D05 Cover Plates

Parallel Circuit Cover Plate

Cover Plate mounting hardware is supplied.
See page 82 for itemized list.

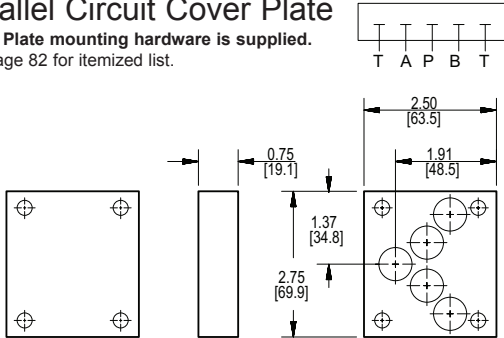

Parallel Circuit Cover Plate with Gauge Port

Cover Plate mounting hardware is supplied.*
See page 82 for itemized list.
* Plug not supplied for metric gauge port.

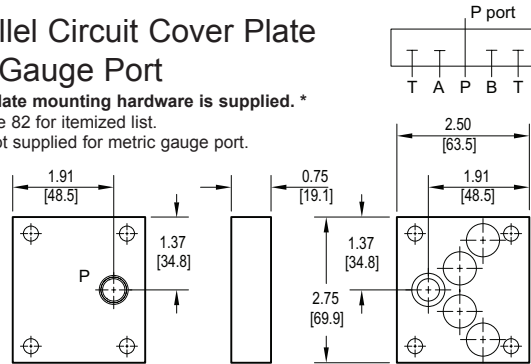

Series Circuit Cover Plate: P to T

Cover Plate mounting hardware is supplied.
See page 82 for itemized list.

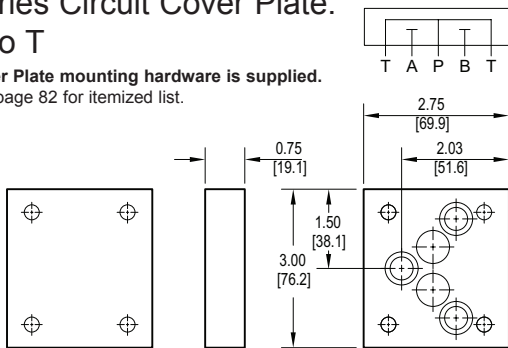

Crossover Cover Plate: P to A; B to T or P to B; A to T

Cover Plate mounting hardware is supplied. See page 82 for itemized list.

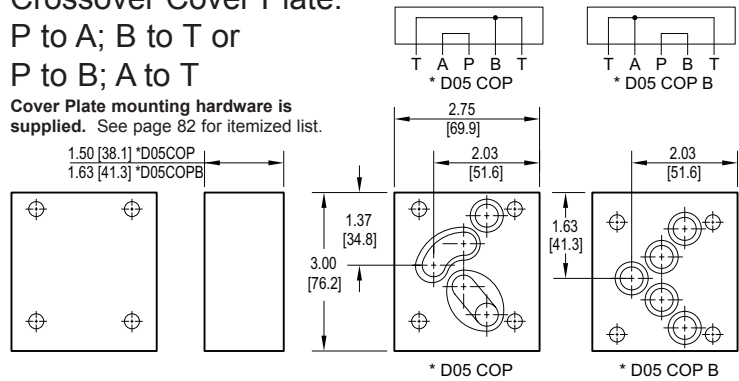

Specifications, descriptions, and dimensional data are subject to correction or change without notice or incurring obligation.
Download latest catalog page revisions at www.daman.com.

Ordering Information

Material	Valve Pattern	Circuit	Gauge Port	Bolt Threads																																
<table border="1"> <thead> <tr> <th colspan="2">Material</th> </tr> </thead> <tbody> <tr> <td>A</td> <td>Aluminum - 6061-T6 COP • 1500† psi • 10.3 MPa Other • 3000† psi • 20.7 MPa</td> </tr> <tr> <td>D</td> <td>Ductile Iron - D4512 COP • 3000† psi • 20.7 MPa Other • 5000† psi • 34.5 MPa</td> </tr> <tr> <td colspan="2">† Working pressure should be considered in accordance with ISO 4413 to determine appropriate material type.</td> </tr> </tbody> </table>	Material		A	Aluminum - 6061-T6 COP • 1500† psi • 10.3 MPa Other • 3000† psi • 20.7 MPa	D	Ductile Iron - D4512 COP • 3000† psi • 20.7 MPa Other • 5000† psi • 34.5 MPa	† Working pressure should be considered in accordance with ISO 4413 to determine appropriate material type.		<table border="1"> <thead> <tr> <th colspan="2">Valve Pattern</th> </tr> </thead> <tbody> <tr> <td>D05</td> <td>ISO 4401-05-04 NFPA T3.5.1-D05 See Tech Information</td> </tr> </tbody> </table>	Valve Pattern		D05	ISO 4401-05-04 NFPA T3.5.1-D05 See Tech Information	<table border="1"> <thead> <tr> <th colspan="2">Circuit</th> </tr> </thead> <tbody> <tr> <td>CPP</td> <td>Parallel Circuit</td> </tr> <tr> <td>CPS</td> <td>Series Circuit</td> </tr> <tr> <td>COP</td> <td>Crossover Circuit (P to A, B to T)</td> </tr> <tr> <td>COPB</td> <td>Crossover Circuit (P to B, A to T)</td> </tr> </tbody> </table>	Circuit		CPP	Parallel Circuit	CPS	Series Circuit	COP	Crossover Circuit (P to A, B to T)	COPB	Crossover Circuit (P to B, A to T)	<table border="1"> <thead> <tr> <th colspan="2">Gauge Port</th> </tr> </thead> <tbody> <tr> <td>G</td> <td>Available with parallel circuit only. Omit if not required. 0.250 NPTF or 0.250 BSPT (M option)</td> </tr> </tbody> </table>	Gauge Port		G	Available with parallel circuit only. Omit if not required. 0.250 NPTF or 0.250 BSPT (M option)	<table border="1"> <thead> <tr> <th colspan="2">Bolt Threads</th> </tr> </thead> <tbody> <tr> <td colspan="2">Omit for inch (UNC) bolt kit.</td> </tr> <tr> <td>M</td> <td>Metric (ISO 6H) bolt kit</td> </tr> </tbody> </table>	Bolt Threads		Omit for inch (UNC) bolt kit.		M	Metric (ISO 6H) bolt kit
Material																																				
A	Aluminum - 6061-T6 COP • 1500† psi • 10.3 MPa Other • 3000† psi • 20.7 MPa																																			
D	Ductile Iron - D4512 COP • 3000† psi • 20.7 MPa Other • 5000† psi • 34.5 MPa																																			
† Working pressure should be considered in accordance with ISO 4413 to determine appropriate material type.																																				
Valve Pattern																																				
D05	ISO 4401-05-04 NFPA T3.5.1-D05 See Tech Information																																			
Circuit																																				
CPP	Parallel Circuit																																			
CPS	Series Circuit																																			
COP	Crossover Circuit (P to A, B to T)																																			
COPB	Crossover Circuit (P to B, A to T)																																			
Gauge Port																																				
G	Available with parallel circuit only. Omit if not required. 0.250 NPTF or 0.250 BSPT (M option)																																			
Bolt Threads																																				
Omit for inch (UNC) bolt kit.																																				
M	Metric (ISO 6H) bolt kit																																			

For **coating options**
see pages 245-246.

D05 Cover Plates with Pilot Ports

Parallel Circuit Cover Plate with Gauge Port

Cover Plate mounting hardware is supplied. *
See page 82 for itemized list.
* Plug not supplied for metric gauge port.

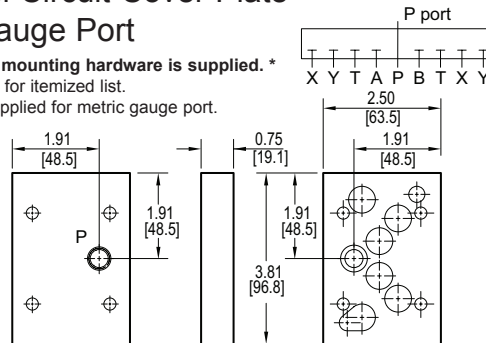

Series Circuit Cover Plate: P to T

Cover Plate mounting hardware is supplied.
See page 82 for itemized list.

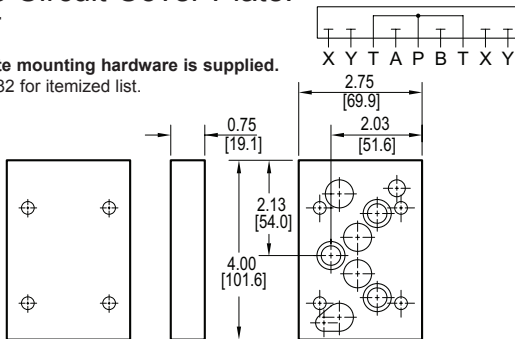

Crossover Cover Plate: P to A; B to T

Cover Plate mounting hardware is supplied.
See page 82 for itemized list.

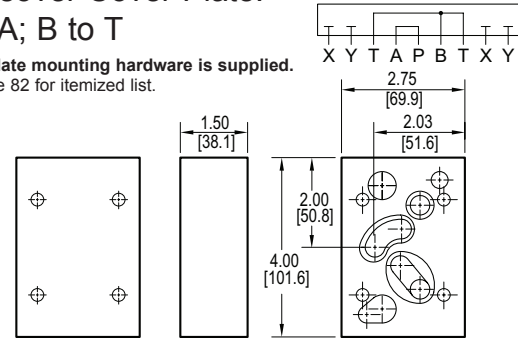

Specifications, descriptions, and dimensional data are subject to correction or change without notice or incurring obligation.
Download latest catalog page revisions at www.daman.com.

Ordering Information

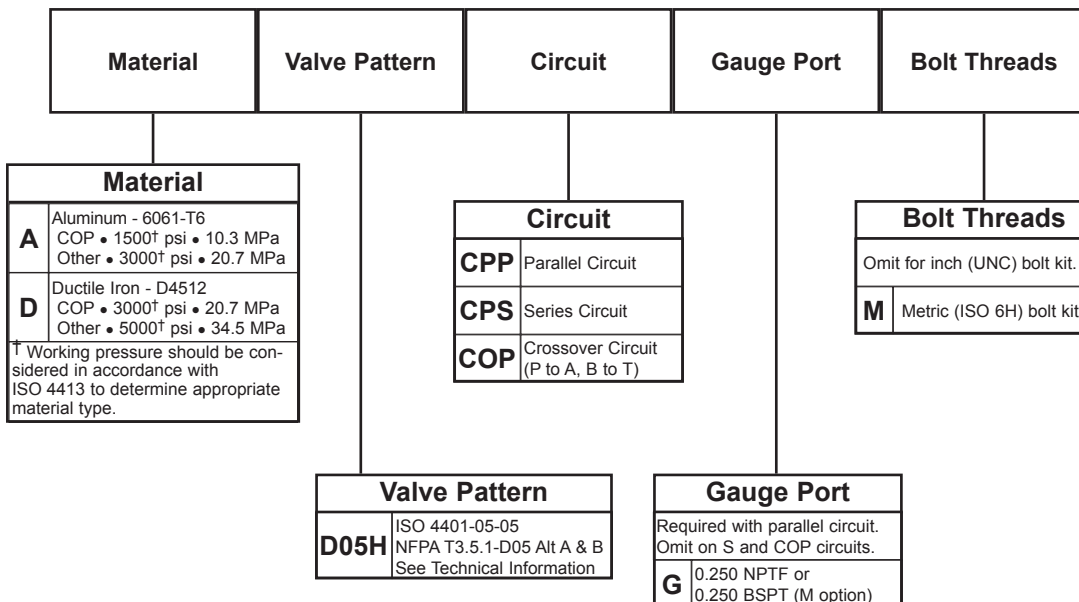

For **coating options**
see pages 245-246.

D07 Cover Plates

Parallel Circuit Cover Plate with Gauge Port

Cover Plate mounting hardware is supplied.*
See page 82 for itemized list.
* Plug not supplied for metric gauge port.

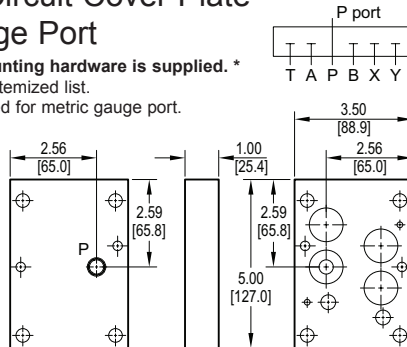

Series Circuit Cover Plate: P to T

Cover Plate mounting hardware is supplied.
See page 82 for itemized list.

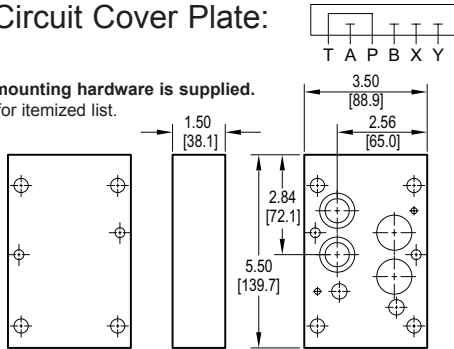

Crossover Cover Plate: P to A; B to T

Cover Plate mounting hardware is supplied.
See page 82 for itemized list.

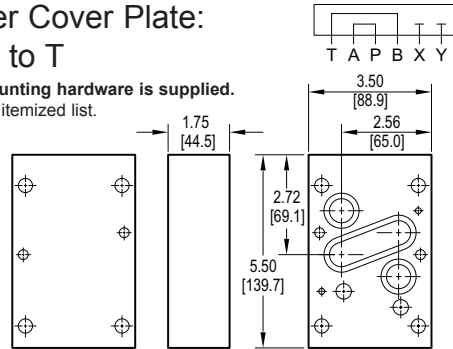

Specifications, descriptions, and dimensional data are subject to correction or change without notice or incurring obligation. Download latest catalog page revisions at www.daman.com.

Ordering Information

Material	Valve Pattern	Circuit	Gauge Port	Bolt Threads																																
<table border="1"> <thead> <tr> <th colspan="2">Material</th> </tr> </thead> <tbody> <tr> <td>A</td> <td>Aluminum - 6061-T6 COP • 1500† psi • 10.3 MPa Other • 3000† psi • 20.7 MPa</td> </tr> <tr> <td>D</td> <td>Ductile Iron - D4512 COP • 3000† psi • 20.7 MPa Other • 5000† psi • 34.5 MPa</td> </tr> <tr> <td colspan="2">† Working pressure should be considered in accordance with ISO 4413 to determine appropriate material type.</td> </tr> </tbody> </table>	Material		A	Aluminum - 6061-T6 COP • 1500† psi • 10.3 MPa Other • 3000† psi • 20.7 MPa	D	Ductile Iron - D4512 COP • 3000† psi • 20.7 MPa Other • 5000† psi • 34.5 MPa	† Working pressure should be considered in accordance with ISO 4413 to determine appropriate material type.		<table border="1"> <thead> <tr> <th colspan="2">Valve Pattern</th> </tr> </thead> <tbody> <tr> <td>D07</td> <td>ISO 4401-07-06 NFPA T3.5.1-D07 See Tech Information</td> </tr> </tbody> </table>	Valve Pattern		D07	ISO 4401-07-06 NFPA T3.5.1-D07 See Tech Information	<table border="1"> <thead> <tr> <th colspan="2">Circuit</th> </tr> </thead> <tbody> <tr> <td>CPP</td> <td>Parallel Circuit</td> </tr> <tr> <td>CPS</td> <td>Series Circuit</td> </tr> <tr> <td>COP</td> <td>Crossover Circuit (P to A, B to T)</td> </tr> </tbody> </table>	Circuit		CPP	Parallel Circuit	CPS	Series Circuit	COP	Crossover Circuit (P to A, B to T)	<table border="1"> <thead> <tr> <th colspan="2">Gauge Port</th> </tr> </thead> <tbody> <tr> <td colspan="2">Available with parallel circuit. Omit on S and COP circuits.</td> </tr> <tr> <td>G</td> <td>0.250 NPTF or 0.250 BSPT (M option)</td> </tr> </tbody> </table>	Gauge Port		Available with parallel circuit. Omit on S and COP circuits.		G	0.250 NPTF or 0.250 BSPT (M option)	<table border="1"> <thead> <tr> <th colspan="2">Bolt Threads</th> </tr> </thead> <tbody> <tr> <td colspan="2">Omit for inch (UNC) bolt kit.</td> </tr> <tr> <td>M</td> <td>Metric (ISO 6H) bolt kit</td> </tr> </tbody> </table>	Bolt Threads		Omit for inch (UNC) bolt kit.		M	Metric (ISO 6H) bolt kit
Material																																				
A	Aluminum - 6061-T6 COP • 1500† psi • 10.3 MPa Other • 3000† psi • 20.7 MPa																																			
D	Ductile Iron - D4512 COP • 3000† psi • 20.7 MPa Other • 5000† psi • 34.5 MPa																																			
† Working pressure should be considered in accordance with ISO 4413 to determine appropriate material type.																																				
Valve Pattern																																				
D07	ISO 4401-07-06 NFPA T3.5.1-D07 See Tech Information																																			
Circuit																																				
CPP	Parallel Circuit																																			
CPS	Series Circuit																																			
COP	Crossover Circuit (P to A, B to T)																																			
Gauge Port																																				
Available with parallel circuit. Omit on S and COP circuits.																																				
G	0.250 NPTF or 0.250 BSPT (M option)																																			
Bolt Threads																																				
Omit for inch (UNC) bolt kit.																																				
M	Metric (ISO 6H) bolt kit																																			

For **coating options** see pages 245-246.

D08 Cover Plates

Parallel Circuit Cover Plate

Cover Plate mounting hardware is supplied.
See page 83 for itemized list.

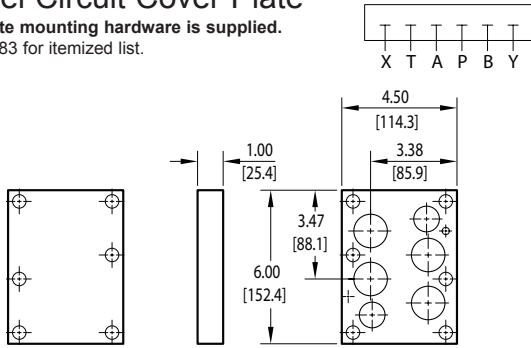

Parallel Circuit Cover Plate with Gauge Port

Cover Plate mounting hardware is supplied.*
See page 83 for itemized list.
* Plug not supplied for metric gauge port.

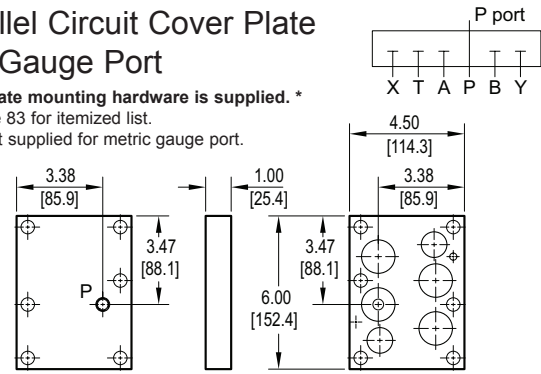

Series Circuit Cover Plate: P to T

Cover Plate mounting hardware is supplied.
See page 83 for itemized list.

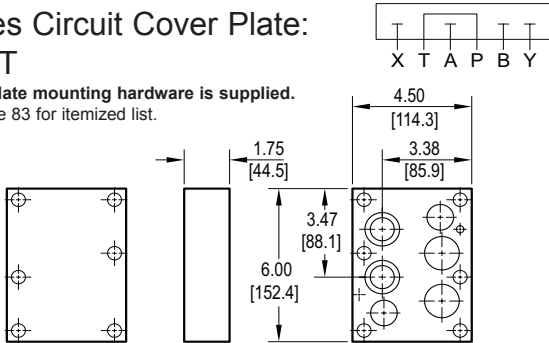

Crossover Cover Plate: P to A; B to T

Cover Plate mounting hardware is supplied.
See page 83 for itemized list.

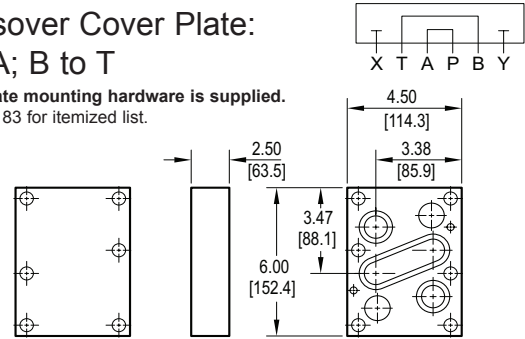

Specifications, descriptions, and dimensional data are subject to correction or change without notice or incurring obligation.
Download latest catalog page revisions at www.daman.com.

Ordering Information

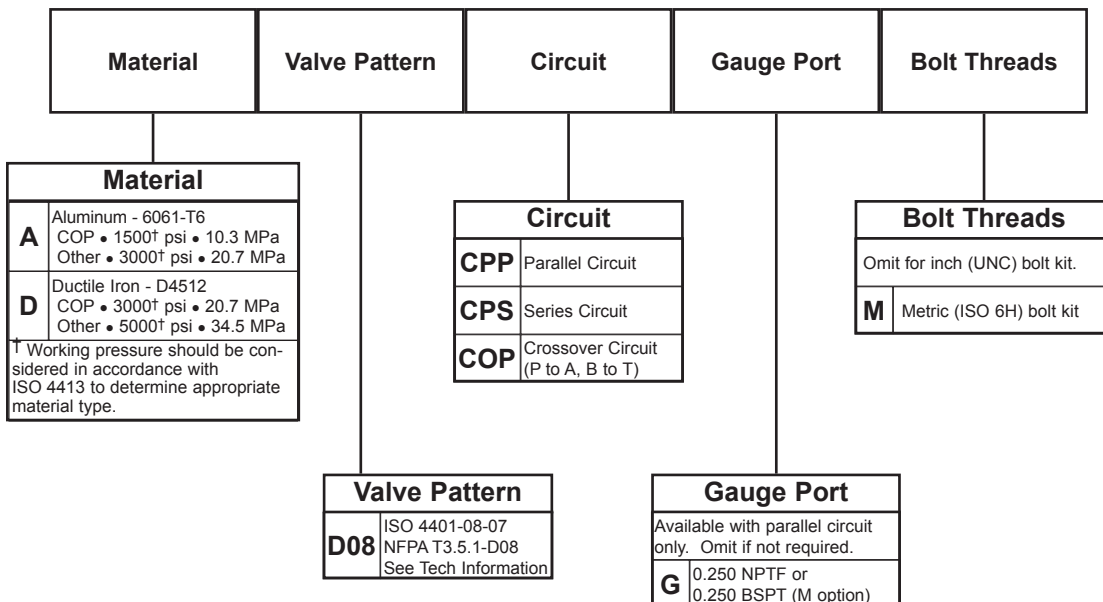

For **coating options** see pages 245-246.

D10 Cover Plates

Parallel Circuit Cover Plate

Cover Plate mounting hardware is supplied.
See page 83 for itemized list.

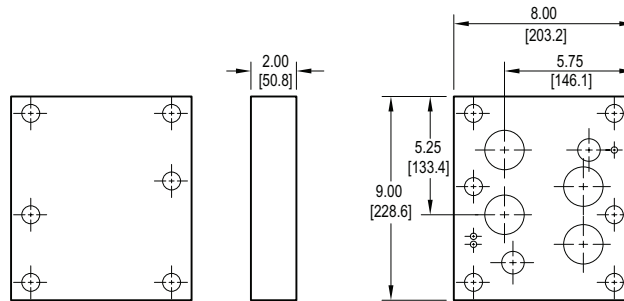

Specifications, descriptions, and dimensional data are subject to correction or change without notice or incurring obligation. Download latest catalog page revisions at www.daman.com.

Ordering Information

Material	Valve Pattern	Circuit	Bolt Threads
----------	---------------	---------	--------------

For **coating options** see pages 245-246.

Material	
A	Aluminum - 6061-T6 3000 [†] psi • 20.7 MPa
D	Ductile Iron - D4512 5000 [†] psi • 34.5 MPa

[†] Working pressure should be considered in accordance with ISO 4413 to determine appropriate material type.

Circuit	
CPP	Parallel Circuit

Bolt Threads	
Omit for inch (UNC) bolt kit.	
M	Metric (ISO 6H) bolt kit

Valve Pattern	
D10	ISO 4401-10-08 NFPA T3.5.1-D10 See Tech Information

2F06, 2F07 Flow Control Cover Plates

Parallel Circuit Cover Plate 2F06 Pattern

Cover Plate mounting hardware is supplied.
See page 83 for itemized list.

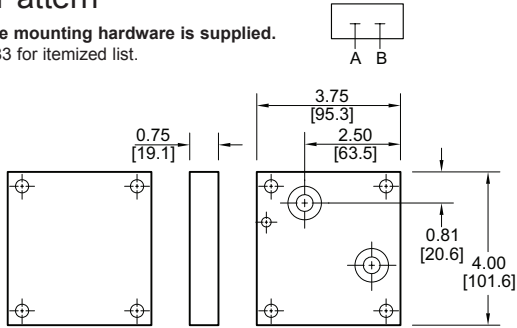

Parallel Circuit Cover Plate 2F07 Pattern

Cover Plate mounting hardware is supplied.
See page 83 for itemized list.

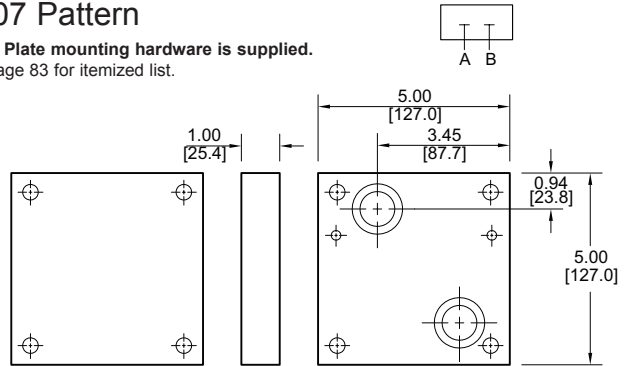

Specifications, descriptions, and dimensional data are subject to correction or change without notice or incurring obligation. Download latest catalog page revisions at www.daman.com.

Ordering Information

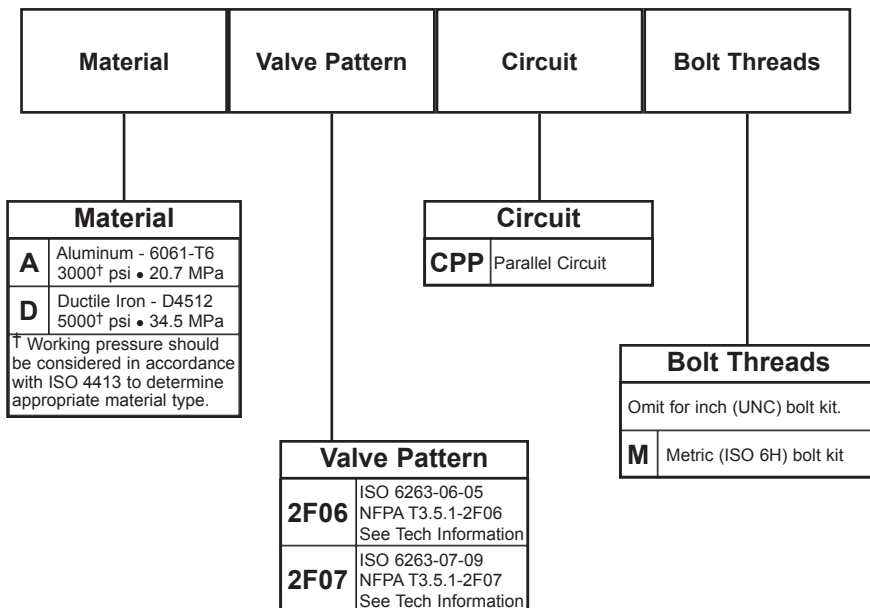

For **coating options**
see pages 245-246.

P06, P08, P10 Pressure Control Cover Plates

Parallel Circuit Cover Plate P06 Pattern

Cover Plate mounting hardware is supplied.
See page 83 for itemized list.

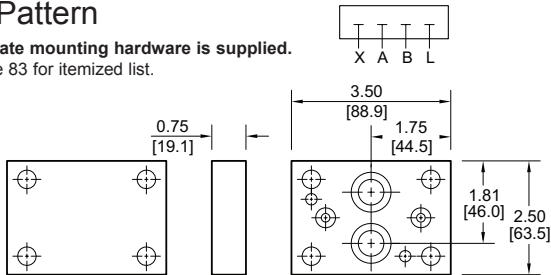

Parallel Circuit Cover Plate P08 Pattern

Cover Plate mounting hardware is supplied.
See page 83 for itemized list.

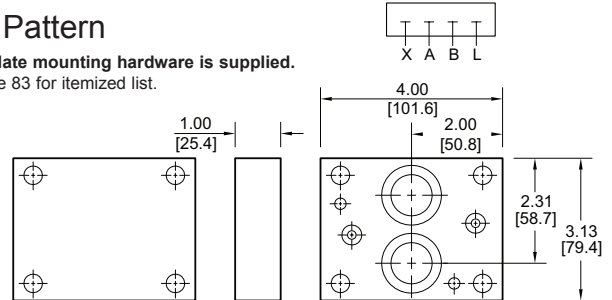

Parallel Circuit Cover Plate P10 Pattern

Cover Plate mounting hardware is supplied.
See page 83 for itemized list.

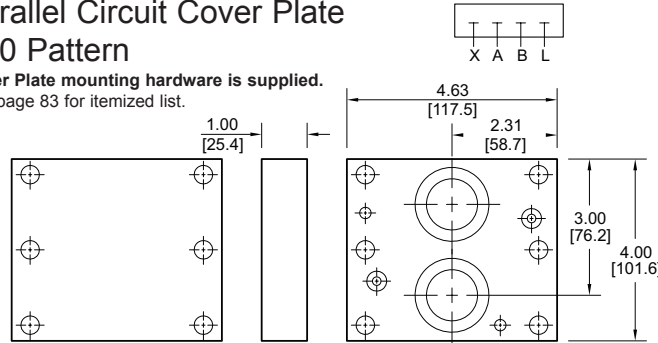

Specifications, descriptions, and dimensional data are subject to correction or change without notice or incurring obligation. Download latest catalog page revisions at www.daman.com.

Ordering Information

Material	Valve Pattern	Circuit	Bolt Threads
----------	---------------	---------	--------------

For **coating options**
see pages 245-246.

Material	
A	Aluminum - 6061-T6 3000† psi • 20.7 MPa
D	Ductile Iron - D4512 5000† psi • 34.5 MPa

Valve Pattern	
P06	ISO 6264-06-07 ISO 5781-06-07 NFPA T3.5.1-[R]P06 See Tech Information
P08	ISO 6264-08-11 ISO 5781-08-10 NFPA T3.5.1-[R]P08 See Tech Information
P10	ISO 6264-10-15 ISO 5781-10-13 NFPA T3.5.1-[R]P10 See Tech Information

Circuit	
CPP	Parallel Circuit

Bolt Threads	
Omit for inch (UNC) bolt kit.	
M	Metric (ISO 6H) bolt kit

† Working pressure should be considered in accordance with ISO 4413 to determine appropriate material type.

R06, R08, I08, R10, I10 Relief Valve Cover Plates

Parallel Circuit Cover Plate R06 (I06) Pattern

Cover Plate mounting hardware is supplied.
See page 83 for itemized list.

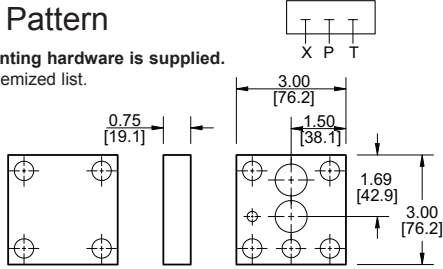

Parallel Circuit Cover Plate R08 or I08 (NFPA RV08) Pattern

Cover Plate mounting hardware is supplied.
See page 83 for itemized list.

Dimension	A	B
R08CPP	4.63 [117.5]	2.81 [71.4]
I08CPP	4.00 [101.6]	2.56 [65.1]

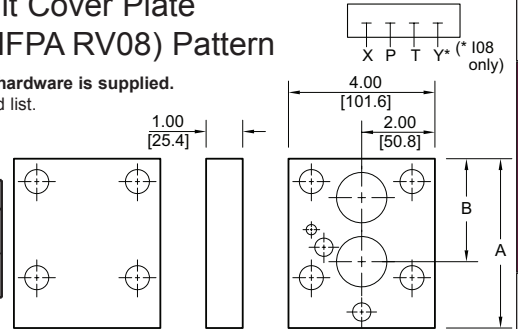

Parallel Circuit Cover Plate R10 Pattern

Cover Plate mounting hardware is supplied.
See page 83 for itemized list.

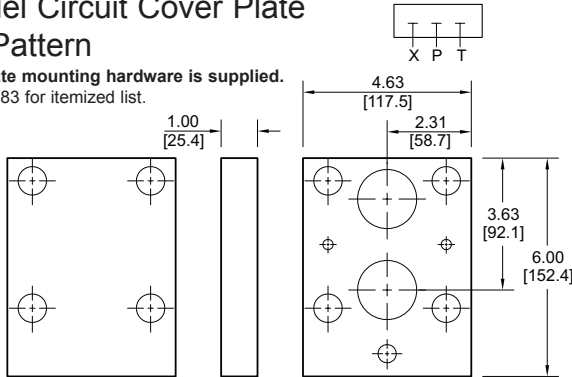

Parallel Circuit Cover Plate I10 (NFPA RV10) Pattern

Cover Plate mounting hardware is supplied.
See page 83 for itemized list.

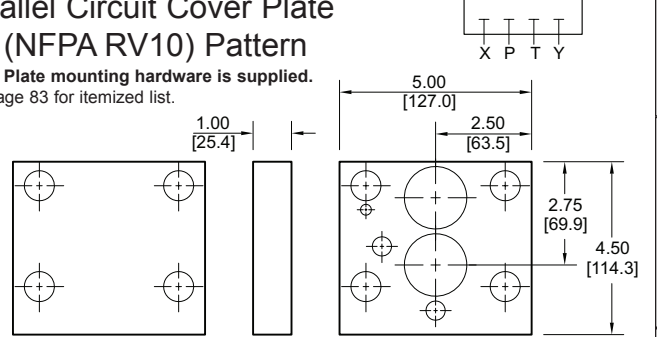

Specifications, descriptions, and dimensional data are subject to correction or change without notice or incurring obligation. Download latest catalog page revisions at www.daman.com.

Ordering Information

Material	Valve Pattern	Circuit	Bolt Threads
----------	---------------	---------	--------------

For **coating options**
see pages 245-246.

Material	
A	Aluminum - 6061-T6 3000 [†] psi • 20.7 MPa
D	Ductile Iron - D4512 5000 [†] psi • 34.5 MPa
[†] Working pressure should be considered in accordance with ISO 4413 to determine appropriate material type.	

Valve Pattern	
R06	ISO 6264-06-09 NFPA T3.5.1-R06 See Tech Information
R08	ISO 6264-08-13 NFPA T3.5.1-R08 See Tech Information
I08	NFPA T3.5.1-RV08 See Tech Information
R10	ISO 6264-10-17 NFPA T3.5.1-R10 See Tech Information
I10	NFPA T3.5.1-RV10 See Tech Information

Circuit	
CPP	Parallel Circuit

Bolt Threads	
Omit for inch (UNC) bolt kit.	
M	Metric (ISO 6H) bolt kit

S04, S06 Servo Valve Cover Plates

Parallel Circuit Cover Plate S04 Pattern

Cover Plate mounting hardware is supplied.
See page 83 for itemized list.

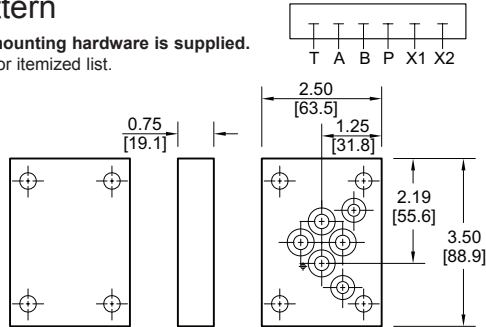

Parallel Circuit Cover Plate S06 Pattern

Cover Plate mounting hardware is supplied.
See page 83 for itemized list.

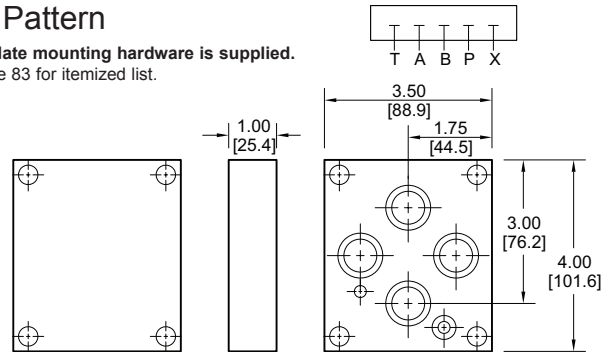

Specifications, descriptions, and dimensional data are subject to correction or change without notice or incurring obligation. Download latest catalog page revisions at www.daman.com.

Ordering Information

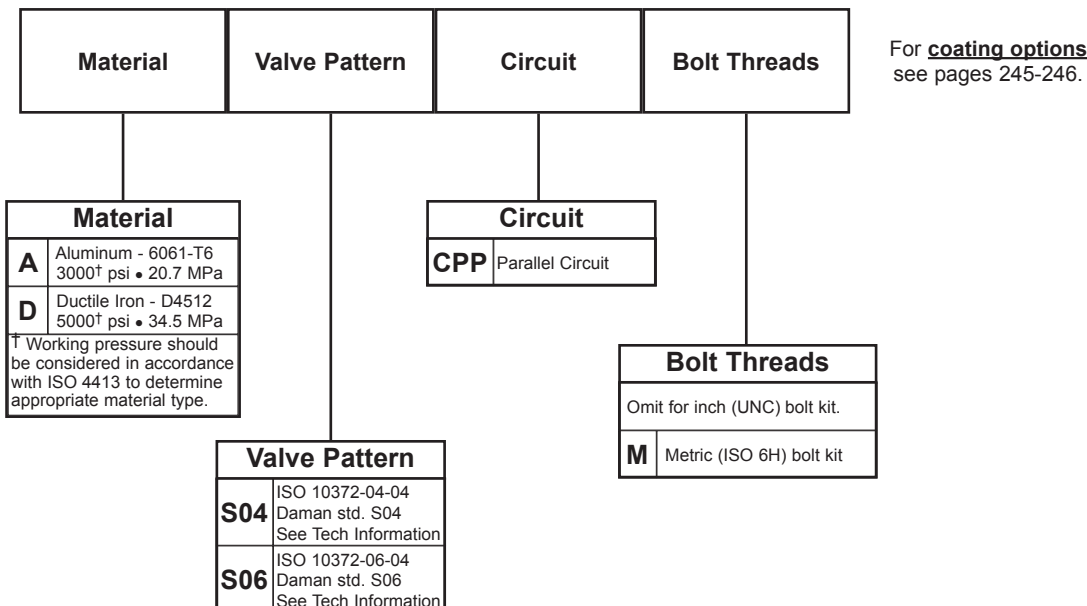

S04, S06 Servo Valve Cover Plates

S04 Crossover Cover Plate: P to A; B to T

Cover Plate mounting hardware is supplied.
See page 83 for itemized list.

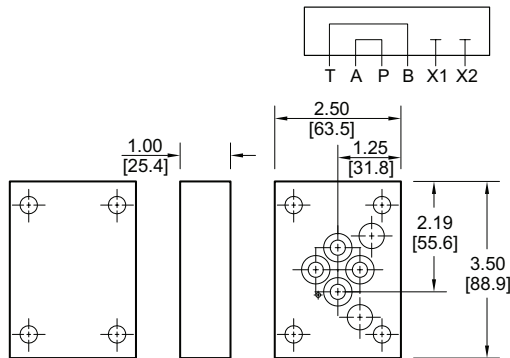

S06 Crossover Cover Plate: P to A; B to T

Cover Plate mounting hardware is supplied.
See page 83 for itemized list.

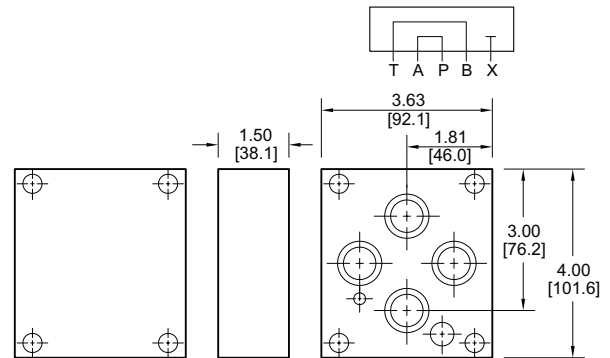

Specifications, descriptions, and dimensional data are subject to correction or change without notice or incurring obligation.
Download latest catalog page revisions at www.daman.com.

Ordering Information

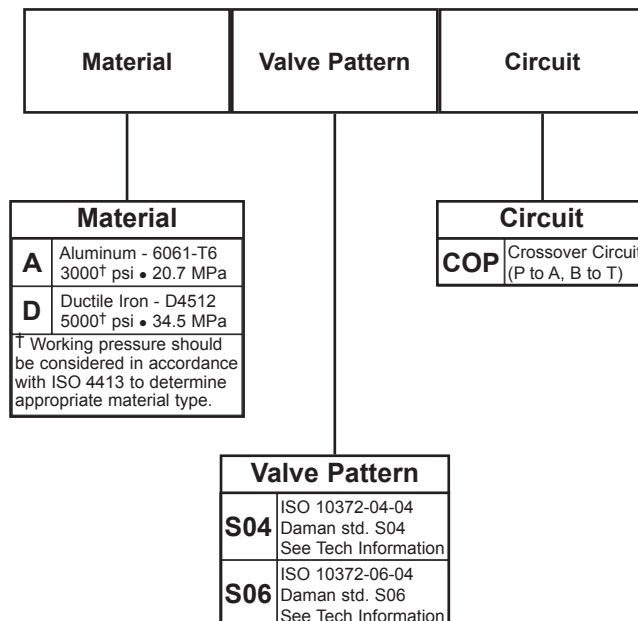

For **coating options**
see pages 245-246.

Cover Plate Mounting Hardware

AVAILABLE FOR PURCHASE. ORDERING INFORMATION: REMOVE ASTERISK AND ADD "185-" TO BEGINNING OF PART NUMBER LISTED. CONSULT PRICE LIST FOR PRICING.

Part no.	Pg.	GA port Plug	Viton O-rings, 90 duro.	Mounting Screws	Locating Pins
* D02 CP P G * D02 CP S * D02 COP	70	(1) 0.12-27 NPTF n/a n/a	(4) -010 (4) -010 (2) -015	(4) UNC #10-24 x 1.00 long SHCS	(1) 0.12 dia x 0.25 long
* D02 CP P G M * D02 CP S M * D02 COP M	70	n/a n/a n/a	(4) -010 (4) -010 (2) -015	(4) ISO 6H M5-0.8 x 25mm SHCS	
* D03 CP P * D03 CP P G * D03 CP S * D03 COP * D03 COPB	71	n/a (1) 0.12-27 NPTF n/a n/a n/a	(4) -012 (4) -012 (4) -012 (2) -016 (2) -016	(4) UNC #10-24 x 1.00 long SHCS	(1) 0.12 dia x 0.25 long
* D03 CP P M * D03 CP P G M * D03 CP S M * D03 COP M * D03 COPB M	71	n/a n/a n/a n/a n/a	(4) -012 (4) -012 (4) -012 (2) -016 (2) -016	(4) ISO 6H M5-0.8 x 25mm SHCS	
* D05 CP P * D05 CP P G * D05 CP S * D05 COP * D05 COPB	72	n/a (1) 0.25-18 NPTF n/a n/a n/a	(5) -014 (5) -014 (5) -014 (1) -014; (2) -022 (5) -014	(4) UNC 0.25-20 x 1.25 long SHCS (4) UNC 0.25-20 x 1.25 long SHCS (4) UNC 0.25-20 x 1.25 long SHCS (4) UNC 0.25-20 x 2.00 long SHCS (4) UNC 0.25-20 x 2.00 long SHCS	n/a
* D05 CP P M * D05 CP P G M * D05 CP S M * D05 COP M * D05 COPB M	72	n/a n/a n/a n/a n/a	(5) -014 (5) -014 (5) -014 (1) -014; (2) -022 (5) -014	(4) ISO 6H M6-1.0 x 30mm SHCS (4) ISO 6H M6-1.0 x 30mm SHCS (4) ISO 6H M6-1.0 x 30mm SHCS (4) ISO 6H M6-1.0 x 50mm SHCS (4) ISO 6H M6-1.0 x 50mm SHCS	
* D05H CP P G * D05H CP S * D05H COP	73	(1) 0.25-18 NPTF n/a n/a	(1) -011; (6) -014; (1) -016 (1) -011; (6) -014; (1) -016 (1) -011; (2) -014; (1) -016; (2) -022	(4) UNC 0.25-20 x 1.25 long SHCS (4) UNC 0.25-20 x 1.25 long SHCS (4) UNC 0.25-20 x 2.00 long SHCS	n/a
* D05H CP P G M * D05H CP S M * D05H COP M	73	n/a n/a n/a	(1) -011; (6) -014; (1) -016 (1) -011; (6) -014; (1) -016 (1) -011; (2) -014; (1) -016; (2) -022	(4) ISO 6H M6-1.0 x 30mm SHCS (4) ISO 6H M6-1.0 x 30mm SHCS (4) ISO 6H M6-1.0 x 50mm SHCS	
* D07 CP P G * D07 CP S * D07 COP	74	(1) 0.25-18 NPTF n/a n/a	(2) -011; (4) -210 (2) -011; (4) -210 (2) -011; (2) -210; (1) -225	(4) UNC 0.38-16 x 1.75 long and (2) UNC 0.25-20 x 1.50 long SHCS (4) UNC 0.38-16 x 2.00 long and (2) UNC 0.25-20 x 2.00 long SHCS (4) UNC 0.38-16 x 2.50 long and (2) UNC 0.25-20 x 2.25 long SHCS	(2) 0.12 dia x 0.25 long
* D07 CP P G M * D07 CP S M * D07 COP M	74	n/a n/a n/a	(2) -011; (4) -210 (2) -011; (4) -210 (2) -011; (2) -210; (1) -225	(4) ISO 6H M10-1.5 x 40mm and (2) ISO 6H M6-1.0 x 35mm SHCS (4) ISO 6H M10-1.5 x 50mm and (2) ISO 6H M6-1.0 x 50mm SHCS (4) ISO 6H M10-1.5 x 60mm and (2) ISO 6H M6-1.0 x 55mm SHCS	

Cover Plate Mounting Hardware

AVAILABLE FOR PURCHASE. ORDERING INFORMATION: REMOVE ASTERISK AND ADD "185-" TO BEGINNING OF PART NUMBER LISTED. CONSULT PRICE LIST FOR PRICING.

Part no.	Pg.	GA port Plug	Viton O-rings, 90 duro.	Mounting Screws	Locating Pins
* D08 CP P * D08 CP P G * D08 CP S * D08 COP	75	n/a (1) 0.25-18 NPTF n/a n/a	(2) -210; (4) -215 (2) -210; (4) -215 (2) -210; (4) -215 (2) -210; (2) -215; (1) -231	(6) UNC 0.50-13 x 1.75 long SHCS (6) UNC 0.50-13 x 1.75 long SHCS (6) UNC 0.50-13 x 2.50 long SHCS (6) UNC 0.50-13 x 3.50 long SHCS	(2) 0.25 dia x 0.50 long
* D08 CP P M * D08 CP P G M * D08 CP S M * D08 COP M	75	n/a n/a n/a n/a	(2) -210; (4) -215 (2) -210; (4) -215 (2) -210; (4) -215 (2) -210; (2) -215; (1) -231	(6) ISO 6H M12-1.75 x 45mm SHCS (6) ISO 6H M12-1.75 x 45mm SHCS (6) ISO 6H M12-1.75 x 65mm SHCS (6) ISO 6H M12-1.75 x 90mm SHCS	(2) 0.25 dia x 0.50 long
* D10 CP P * D10 CP P M	76	n/a n/a	(2) -210; (4) -222 (2) -210; (4) -222	(6) UNC 0.75-10 x 3.25 long SHCS (6) ISO 6H M20-2.5 x 80mm SHCS	(2) 0.25 dia x 0.50 long
* 2F06 CP P * 2F07 CP P	77	n/a n/a	(2) -018 (2) -215	(4) UNC 0.31-18 x 1.25 long SHCS (4) UNC 0.38-16 x 1.75 long SHCS	(1) 0.25 d. x 0.50 long (2) 0.25 d. x 0.50 long
* 2F06 CP P M * 2F07 CP P M	77	n/a n/a	(2) -018 (2) -215	(4) ISO 6H M8-1.25 x 35mm SHCS (4) ISO 6H M10-1.5 x 45mm SHCS	(1) 0.25 d. x 0.50 long (2) 0.25 d. x 0.50 long
* P06 CP P * P08 CP P * P10 CP P	78	n/a n/a n/a	(2) -011; (2) -018 (2) -011; (2) -215 (2) -011; (2) -220	(4) UNC 0.38-16 x 1.50 long SHCS (4) UNC 0.38-16 x 1.50 long SHCS (6) UNC 0.38-16 x 1.75 long SHCS	(2) 0.25 dia x 0.50 long
* P06 CP P M * P08 CP P M * P10 CP P M	78	n/a n/a n/a	(2) -011; (2) -018 (2) -011; (2) -215 (2) -011; (2) -220	(4) ISO 6H M10-1.5 x 35mm SHCS (4) ISO 6H M10-1.5 x 40mm SHCS (6) ISO 6H M10-1.5 x 45mm SHCS	(2) 0.25 dia x 0.50 long
* R06 CP P * R08 CP P * R10 CP P	79	n/a n/a n/a	(1) -012; (2) -018 (1) -012; (2) -216 (1) -012; (2) -220	(4) UNC 0.50-13 x 1.50 long SHCS (4) UNC 0.63-11 x 2.00 long SHCS (4) UNC 0.75-10 x 2.25 long SHCS	(1) 0.25 d. x 0.50 long (1) 0.25 d. x 0.50 long (2) 0.25 d. x 0.50 long
* R06 CP P M * R08 CP P M * R10 CP P M	79	n/a n/a n/a	(1) -012; (2) -018 (1) -012; (2) -216 (1) -012; (2) -220	(4) ISO 6H M12-1.75 x 40mm SHCS (4) ISO 6H M16-2 x 50mm SHCS (4) ISO 6H M20-2.5 x 55mm SHCS	(1) 0.25 d. x 0.50 long (1) 0.25 d. x 0.50 long (2) 0.25 d. x 0.50 long
* I08 CP P * I10 CP P	79	n/a n/a	(2) -012; (2) -216 (2) -012; (2) -220	(4) UNC 0.63-11 x 2.00 long SHCS (4) UNC 0.75-10 x 2.25 long SHCS	(1) 0.25 dia x 0.50 long
* I08 CP P M * I10 CP P M	79	n/a n/a	(2) -012; (2) -216 (2) -012; (2) -220	(4) ISO 6H M16-2 x 50mm SHCS (4) ISO 6H M20-2.5 x 55mm SHCS	(1) 0.25 dia x 0.50 long
* S04 CP P * S06 CP P	80	n/a n/a	(2) -012; (4) -013 (1) -012; (4) -019	(4) UNC 0.31-18 x 1.50 long SHCS (4) UNC 0.38-16 x 1.75 long SHCS	(1) 0.09 d. x 0.25 long (1) 0.25 d. x 0.50 long
* S04 CP P M * S06 CP P M	80	n/a n/a	(2) -012; (4) -013 (1) -012; (4) -019	(4) ISO 6H M8-1.25 x 30mm SHCS (4) ISO 6H M10-1.5 x 45mm SHCS	(1) 0.09 d. x 0.25 long (1) 0.25 d. x 0.50 long
* S04 COP * S06 COP	81	n/a n/a	(2) -012; (4) -013 (1) -012; (4) -019	(4) UNC 0.31-18 x 1.50 long SHCS (4) UNC 0.38-16 x 2.25 long SHCS	(1) 0.09 d. x 0.25 long (1) 0.25 d. x 0.50 long