

HLT Lifts

Vertical positioning for HMIs

- ***Strong & robust***
- ***Flexible configuration***
- ***Excellent value***
- ***In Stock***



**Designed to connect to
HLT Pendant Arm System**

**Automatic blocking of
vertical stroke possible in
each position.**

**Continuously adjustable lift for
control housing and HMIs.**

**Weight range from 5-60 kg
(11-132 lbs) available**

hawa HLT type lifts
strong, continuously adjustable lift system for vertical positioning

DON'T FIND THE CONFIGURATION YOU NEED?
PLEASE CONTACT HAEWA FOR ANY MODIFICATION
OR CUSTOMIZATION AT 1-800-783-4239

	Configuration	Order No.	Lift Connection Tube	Weight Range	Catalog Page #
HLT Lift S	Standard hanging	7595-7601-13-01	65 mm	13 - 21 kg / 28.5 - 46 lbs	6
		7595-7601-14-01		18 - 28 kg / 40 - 61.5 lbs	
		7595-7601-15-01		26 - 37 kg / 57 - 81.5 lbs	

Other configurations, connection tubes and weight ranges are available. Please contact Haewa customer service for support at 1-800-783-4239 or info@haewa.com.

Technical Information

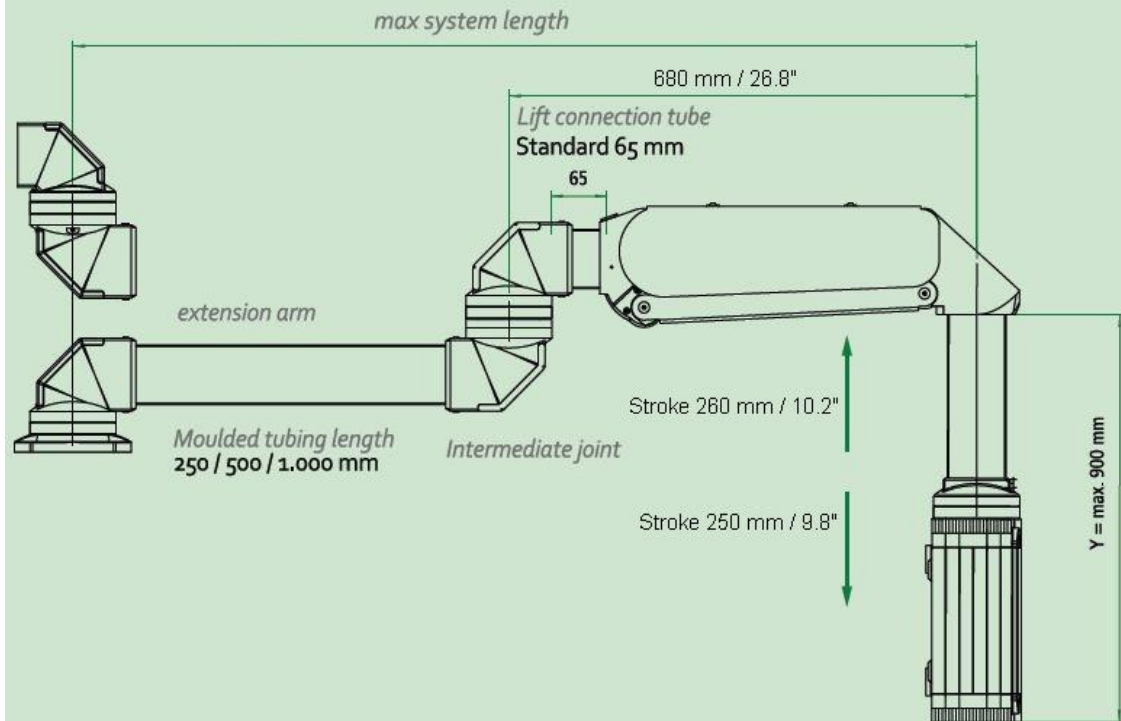

	max. System length	
Weight	without joint	with joint
5-10 kg 11-22 lbs	2000 mm 78.74 inch	2000 mm 78.74 inch
7-13 kg 15.5-28.5 lbs	2000 mm 78.74 inch	2000 mm 78.74 inch
13-21 kg 28.5-46 lbs	2000 mm 78.74 inch	2000 mm 78.74 inch
18-28 kg 40-61.5 lbs	2000 mm 78.74 inch	1800 mm 70.86 inch
26-37 kg 57-81.5 lbs	1700 mm 66.92 inch	1500 mm 59.05 inch
36-52 kg 79.5-114.5 lbs	1300 mm 51.18 inch	1100 mm 43.30 inch
45-60 kg 99-132 lbs	1150 mm 45.27 inch	1000 mm 39.37 inch

Configuration Table

<ul style="list-style-type: none"> Choose your design: 1 = Standard hanging 2 = Desk mounting 3 = Standard hanging; stroke limiter 4 = Desk mounting; stroke limiter e.g. 7595-7601-xx-01 	<ul style="list-style-type: none"> Choose length of lift connection tube 1 = 65 mm Standard 2 = 100 mm 3 = 200 mm 4 = 300 mm 5 = 400 mm 6 = 500 mm e.g. 7595-7601-1x-01 	<ul style="list-style-type: none"> Choose your loading capacity: 1 = 5-10 kg 2 = 7-13 kg 3 = 13-21 kg 4 = 18-28 kg 5 = 26-37 kg 6 = 36-52 kg 7 = 45-60 kg e.g. 7595-7601-11-01
---	---	---

Scope of supply:
- Lift with lift connection tube